

尺寸/公差 (mm)	0	>3	>6	>10	>18	>30	>50	>80	>120	>180	>280	>315	>400	>500	0.1/10
±0.12	±0.18	±0.22	±0.26	±0.31	±0.37	±0.57	±0.80	±0.93	±1.05	±1.15	±1.60	±2.20	±2.50	±Z	±Z

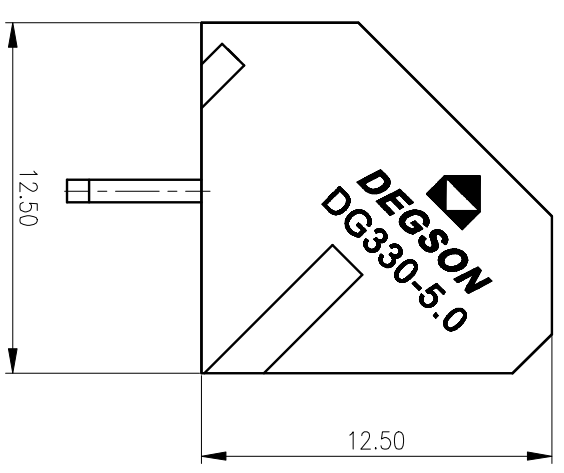

PCB LAYOUT
5.0x(N-1)

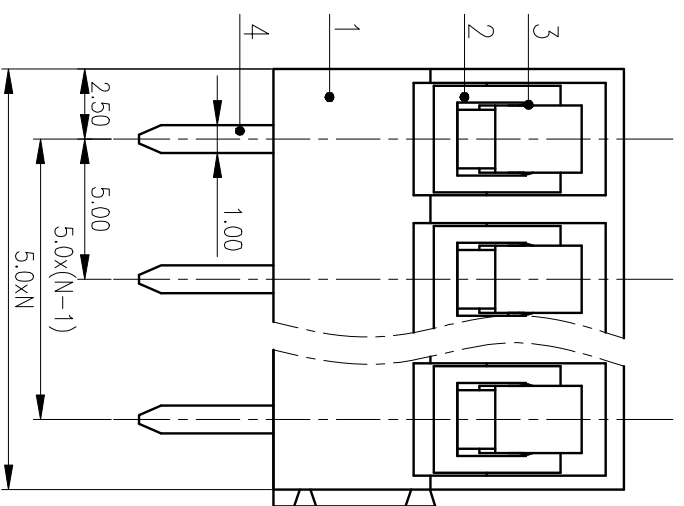
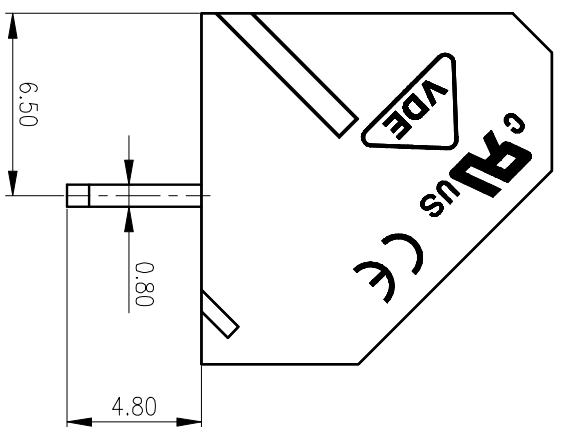
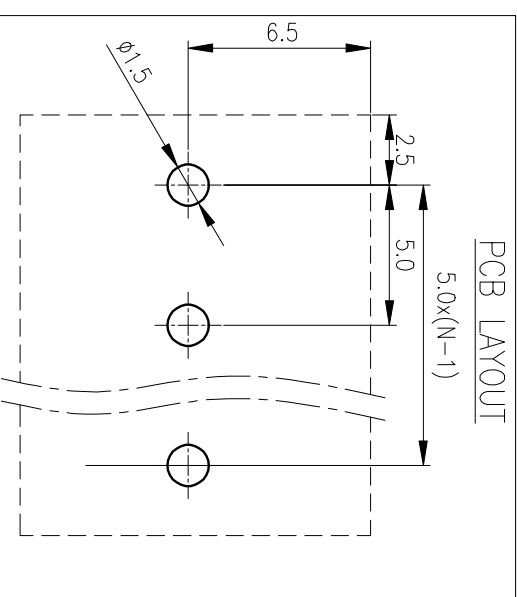

4	Pin header	Copper alloy	Sn plated
3	Screw	Steel	M2.5/Zn Plated
2	Cage	Copper alloy	M2.5/Ni plated
1	Housing	PA66	UL94V-0

UL 标准/UL Standard:	B	C	D
额定电压/电压/Rated Voltage(V)/Current(A)	300/15	/	300/10
IEC 标准/IEC Standard:			
过压类别/Overvoltage Category/污染等级	III/3	III/2	II/2
额定电压/电压/Rated Voltage(V)/Current(A)	/	250/24	/
工频耐压/Withstanding Voltage(V/Min)	/	AC2000	/
拧紧扭矩/Torque Tightening(N·m/Lbin)	M2.5: 0.4	3.5, 5.4	
线径范围(硬线和软线)/Wire Range(rigid and flexible)(mm ² /AWG)	0.5~2.5/22~12		
间距/Pitch(mm)/线数/Number of Poles	5.0/N=02~24P		
剥线长度/Stripping length(mm)	4~5		
使用温度范围/Operating temperature(°C)	-40~+105		
符合RoHS环保要求/Conform to RoHS	Yes		

MATERIAL: /
SURFACE: /
MAT NO.: /
STATUS: /
NAME: **DEGSON® NINGBO DEGSON ELECTRICAL CO., LTD**

APPD: Li GL 2020.06.19
CHKD: Mgo J 2020.06.19
DRAWING NO.: DG330-5.0-C02
NAME: **DG330-5.0-XXP-1Y-00A(H)**

DRAFT: Tong XC 2004.03.25
TYPE: CUSTOMER DRAWING
SCALE: 4:1
REV T0
1/1

REV	ECN	DESCRIPTION	DRAFT	DATE
-----	-----	-------------	-------	------

