

Neo6502

User Manual

Document revision 2.0, June 2024

www.olimex.com

Table of Contents

| | |
|---|----|
| Introduction to Neo6502..... | 3 |
| Order codes for RP2040-PICO30 and accessories:..... | 5 |
| HARDWARE..... | 6 |
| Neo6502 schematics:..... | 6 |
| Neo6502 layout:..... | 7 |
| Neo6502 6502 bus connector:..... | 8 |
| UEXT connector:..... | 9 |
| SOFTWARE:..... | 11 |
| Programming RP2040..... | 12 |
| FAQ..... | 13 |
| Document revision history..... | 14 |

Introduction to Neo6502

The design goal of Neo6502 was to make simple modern retro computer with 6502 processor.

By modern we meant computer with a modern video interface like HDMI, USB keyboard, and USB flash drive as storage. HDMI as everyone has TV with HDMI at home and USB keyboards are the mainstream device for input.

With the task to provide HDMI and USB interface we choose RP2040 which already has DVI bit bang project and USB host.

RP2040 also has enough RAM so we decided to use RP2040 to emulate also the RAM memory for 6502.

For the 6502 processor we choose W65C02 from WDC as they are still in mass production and can be purchased freely.

The Neo name was taken for two reasons, first it implies the modern design, then we liked the analogy with the movie The Matrix as W65C02 lives in a virtual world and thinks it has real memory, video, and keyboard but actually all this is virtual and emulated by the RP2040.

Neo6502 is Open Source Hardware, all CAD files, and firmware are available, so people can study and modify.

The features of Neo6502 are:

- real W65C02 processor executing every instruction as it was executed in early retro computers, no emulation for the processor, all timing is exact;
- RP2040 with 2MB of SPI Flash, easy to load new firmware via drag and drop virtual drive;
- HDMI output;
- USB host which can be used for programming and to connection to keyboard, mouse, USB flash etc;
- Audio buzzer which you can enable/disable;
- Audio 3.5mm connector for external audio amplifier;
- USB-C connector for power supply;
- 6502 BUS connector with all signals;
- UEXT connector with I2C, UART and SPI for connecting to external boards
- 4 position slide switch which allows buzzer enable and connection of RESB, NMIB and IRQB to UEXT GPIO signals if needed;
- RP2040 programming bootloader button;
- Four mounting holes 3.3mm diameter;
- Dimensions 80x55 mm.

+ Important notice: If Neo6502 is not mounted in a box so be careful to not place it on metal surface, nor drop metal objects on top of the PCB! This will lead to damage.

Order codes for RP2040-PICO30 and accessories:

| | |
|---|--|
| <u>Neo6502</u> | industrial-grade modern retro computer |
| <u>Box-Neo6502-B</u> | plastic box with blue logo |
| <u>Box-Neo6502-R</u> | plastic box with red logo |
| <u>USB-CABLE-AM-AM-1-8M</u> | USB-A to A cable necessary for programming RP2040 firmware |
| <u>CABLE-USB-A-C-1M</u> | USB-C cable for power supply |
| <u>CABLE-HDMI-50CM</u> | HDMI cable |
| <u>UEXT modules</u> | UEXT expansion modules for Neo6502 UEXT connector |

HARDWARE

Neo6502 schematics:

Neo6502 latest schematic at time of writing is available at GitHub – [Neo6502_Rev_B1.pdf](#)

All schematics can be found in this repo:

<https://github.com/OLIMEX/Neo6502/tree/main/HARDWARE>

Hardware revision changes here:

<https://github.com/OLIMEX/Neo6502/blob/main/HARDWARE/README.md>

Neo6502 layout:

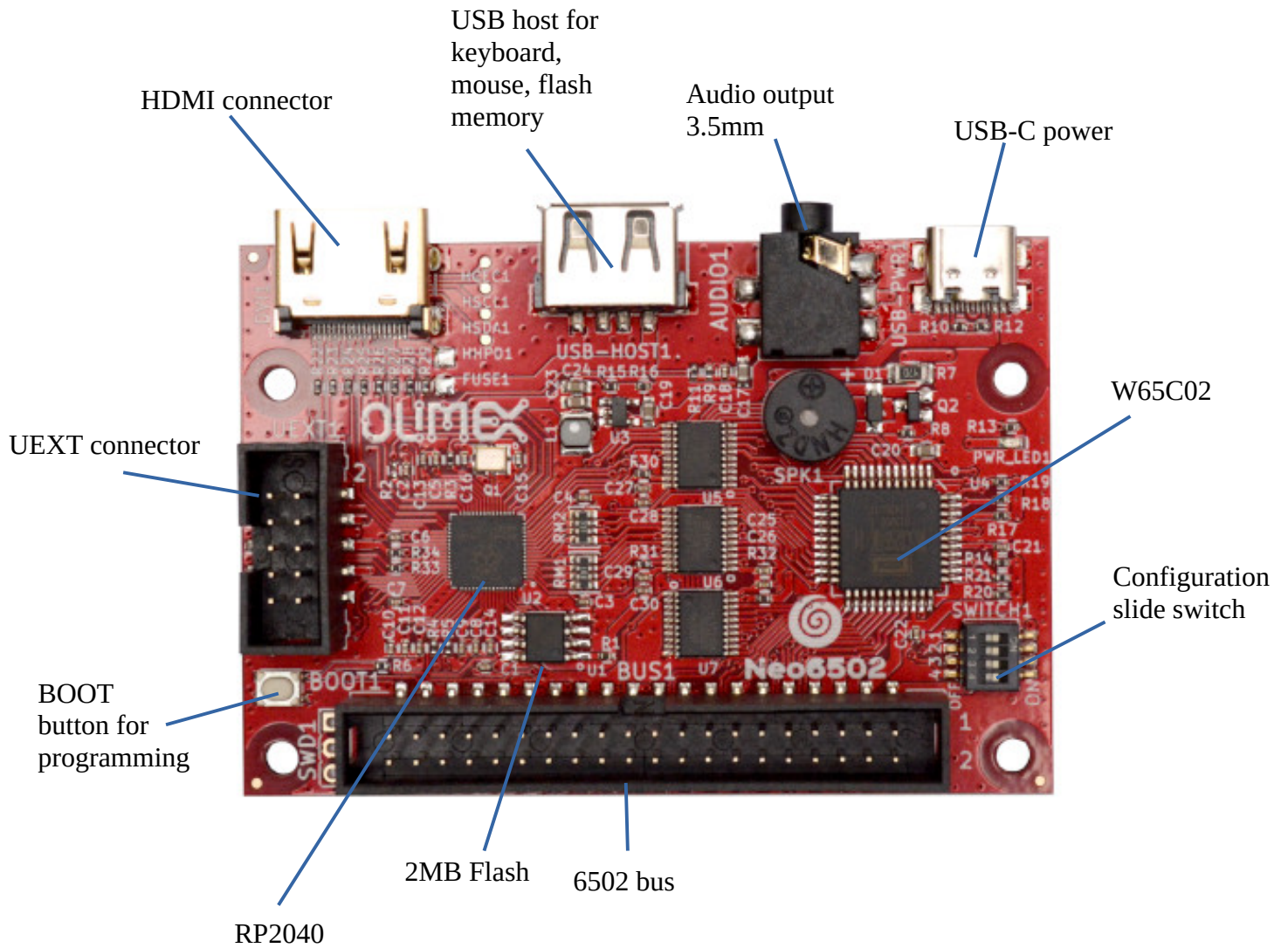

Neo6502 6502 bus connector:

All 6502 signals are available on BUS1 connector for attaching external hardware on it.

+5V, 3.3V, GND

D0-D7, A0-A15, PHI2, R/W, RESB, SOB, MLB, VPB, SYNC, NMIB, IRQB

Two SWD signals (SWDIO, SWCLK) for RP2040 debugging are also present, these should be left free (if not used for debugging), on the external 6502 peripheral boards.

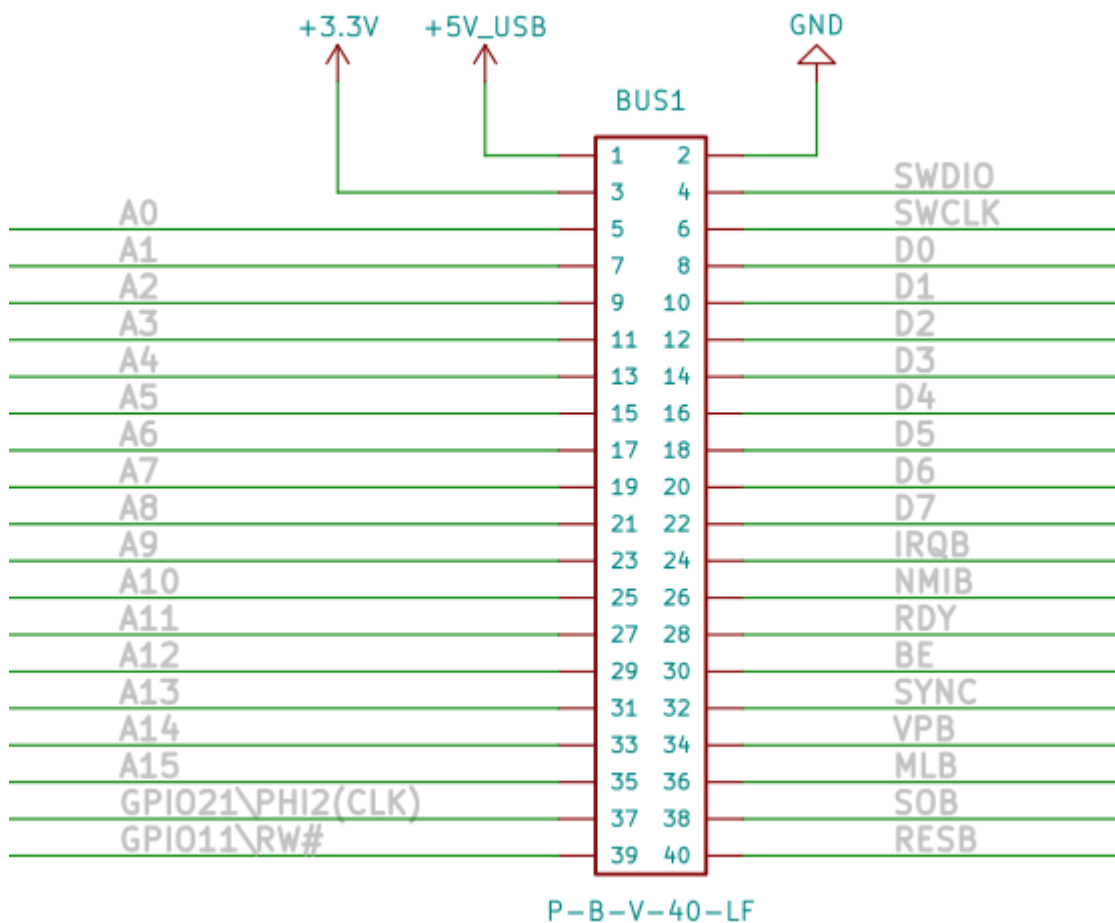

UEXT connector:

UEXT connector stands for Universal EXTension connector and contains +3.3V, GND, I2C, SPI, UART signals.

There are different types of UEXT connectors, but layout is usually the same.

The original UEXT connector is 0.1" 2.54mm step boxed plastic connector. All signals are at 3.3V levels.

UEXT connector

note it share same pins with EXT1 and EXT2

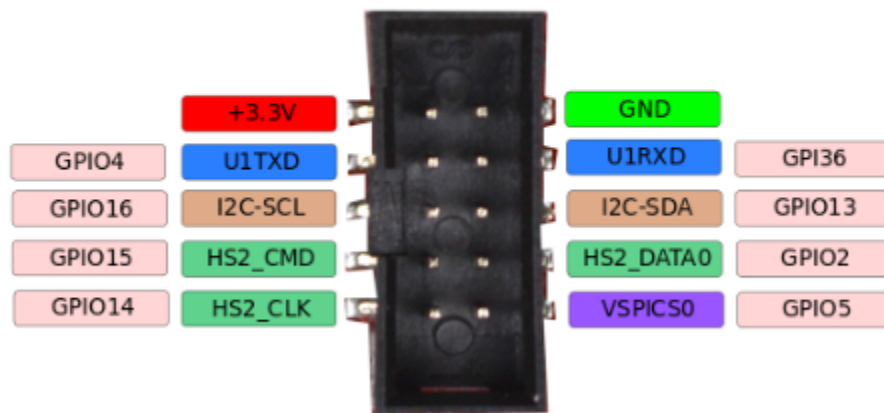

Olimex has developed number of [MODULES](#) with this connector. There are temperature, humidity, pressure, magnetic field, light sensors. Modules with LCDs, LED matrix, relays, Bluetooth, ZigBee, WiFi, GSM, GPS, RFID, RTC, EKG, sensors and etc.

Neo6502 UEXT connector is wired to RP2040 GPIOs as follows:

UEXT

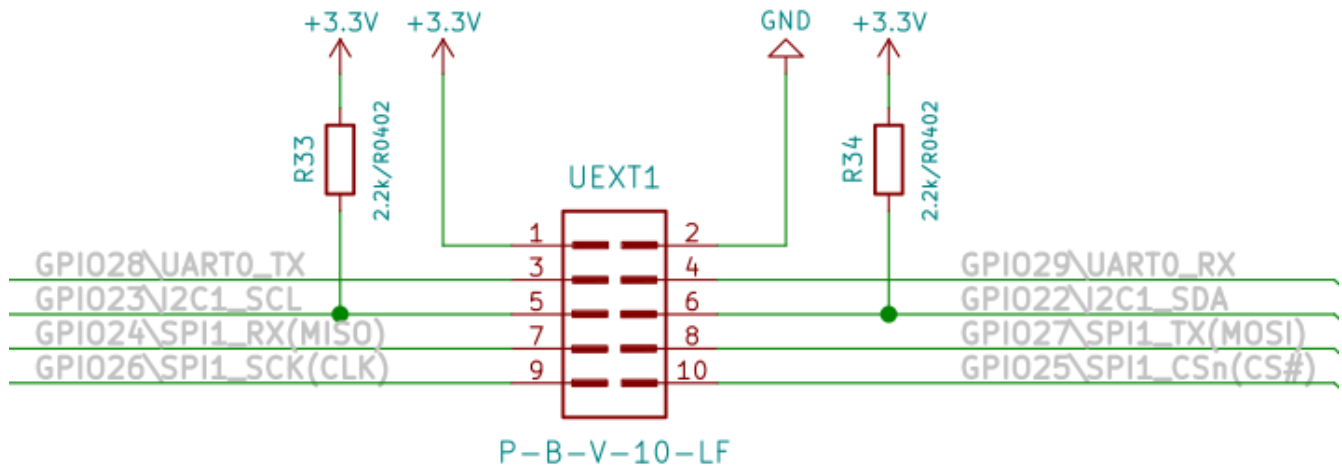

Slide configuration switch can enable/disable the buzzer, also can connect or disconnect RESB, NMIB and IRQB to RP2040 UEXT signals.

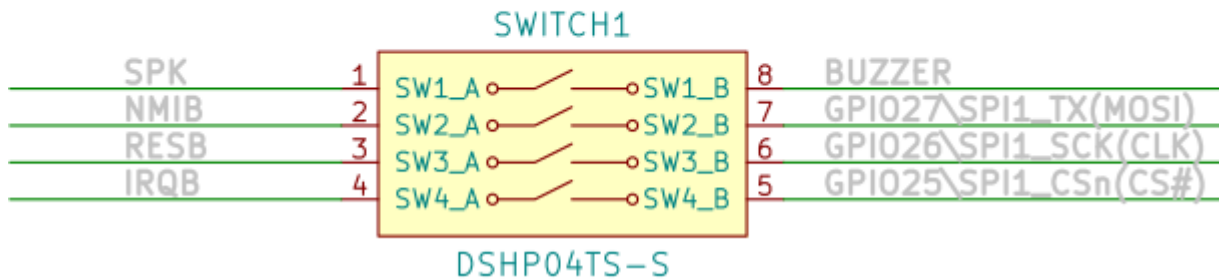

By default Neo6502 is shipped with all sections connected on the switch i.e. buzzer is enabled and all signals are wired to RP2040. This means you can't use SPI on UEXT connector if you do not disconnect these signals.

SOFTWARE:

Neo6502 is open flexible system as everything is virtual and depend on RP2040 firmware, this allow you to emulate old architectures like Apple][and Oric Atmos, or to make your own completely new architecture.

Veselin Sladkov (veselin.sladkov@gmail.com) did amazing work for Neo6502 and created Apple][, Oric Atmos and Apple Iic emulation with [Reload emulator](#).

The reload emulator require some ROMs and disks which are hosted on olimex's [ftp](#).

Rien Matthijsse (rien@marobi.com) made several versions of RP2040 emulator and EHBASIC port working on Neo6502 in his [GitHub repository](#).

Paul Robson (paul@robsons.org.uk) made special version of Neo6502 BASIC on [GitHub](#) and web browser [emulator](#).

Programming RP2040

The RP2040 firmware is UF2 file. You can get pre-build firmware of reload emulator on olimex's ftp.

We recommend you for Apple][to use:

https://ftp.olimex.com/Neo6502/uf2/apple2_800x600_400MHz.uf2

This firmware have latest PRODOS and several games on it ready to play.

For Oric Atmos we recommend you to use:

https://ftp.olimex.com/Neo6502/uf2/oric_960x540_372MHz.uf2

To program the .uf2 files you need USB A to A cable.

You disconnect the power supply USB-C cable, then press the BOOT button and plug the USB-A cable to USB host connector. Your computer will show a new drive. Once this new drive shows copy the .uf2 file to it. Once the firmware is programmed the drive will disappear. This means the RP2040 now has the new firmware loaded.

You need to disconnect the USB-A cable and to attach the USB-C power supply cable, in the USB host you should now plug the keyboard and start working with the emulator.

FAQ

Q: I have LG monitor and there is no picture on the HDMI. I did everything correctly. My board is hardware revision B. Is my board broken?

A: Try all steps again. If problem remains and if you have revision A or B board you might try to close FUSE pads to enable 5V on the HDMI connector. If you have B1 or newer revision FUSE should have a diode component already placed.

To perform the fix look under the HDMI connector, there are two pads that should be empty that have word "FUSE" nearby. Connect the pads together soldering a small wire between them or 0R resistor (the best idea is to solder diode 1N5819/S4 but it has direction so be careful, cathode should be towards HDMI connector, diode would prevent HDMI monitor powering the board). Testing with a wire is fine if you don't have such diode, but if it works in future you might want to buy such diode and solder there (just make sure about the direction).

Document revision history

Revision 1.0 October 2023

Revision 2.0 June 2024

- Formatting and spelling improvements.