

## Euromas Polymas | Enclosure with 2 moulded-on Pg 11



**PK 101-211**

**Order no.: 38101200**

\* = Available on request.

### Characteristics

#### Dimensions

58 x 64 x 34 mm

#### Colour of enclosure group

Silver-grey

#### Protection class

IP 65

#### NEMA

3

#### Enclosure Material

PA 6-GB 30, seal made of CR; for details see Technical Information

#### Scope of delivery

Lid and base, lid screws made of V2A, 2 moulded-on cable glands, Pg 11 including clamping cage, pressure screw and continuous cooling ring

14.11.2024

### Product drawing

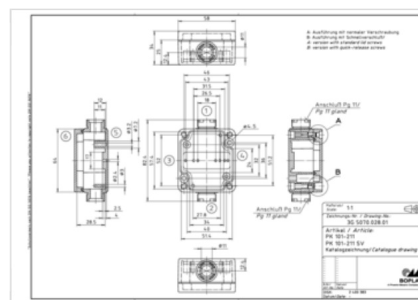

### Enclosure concept

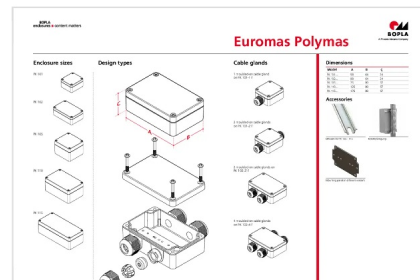

---

## Note

G = Crystal-clear lid.

Note arrangement of cable glands (see photos at start of chapter).

The dimensions are approximate values. The exact values can be found in the respective product drawing.

---

## Important!

---

To compensate for pressure when temperatures change and cause moisture in the enclosure, we recommend that you use a

[pressure compensation](#)

element.

In order to ensure that you can determine **the correct quantity of elements for your application**, we are providing you here with a DAE calculator.

» [Additional information](#)

## Technical documentation / Downloads

---

Technical drawings

### 3D product data in STEP format:

[Login to download](#)

### Drawing for mechanical processing:

38101200 PK-101-211-G.dxf

(2.4 MB)

**Milling contours are shown here as a DXF file. (Sub D, USB, HDMI, cable glands, ...)**

### Product drawing in PDF format:

38101200 PK-101-211.pdf

(54.3 KB)

### Product drawing in DXF format:

38101200 PK-101-211.dxf

(689.0 KB)

Product information

### **euomas-polymas en.pdf**

(588.6 KB)