

Material:

- △ * Housing : LCP With 35% GF/mineral.
or Nylon 9T, UL 94V-0 Color Black
- * Contact: Phosphor Bronze
- * Pick & Place Pad: High Temperature Plastic

Ordering Code

CB50 ** 2 0 0 T 0
 ① ② ③ ④ ⑤ ⑥ ⑦

1. Series No.
2. Contacts: 04~48
3. Plating option :
 - 1= 3.05μm(120μ") Min. Tin plated over 1.27μm(50μ") Nickel
 - 2= 0.05μm(2μ") Min. Gold flash over 1.27μm(50μ") Nickel
 - 3= 0.38μm(15μ") Min. Gold plated over 1.27μm(50μ") Nickel
 - 4= 0.76μm(30μ") Min. Gold plated over 1.27μm(50μ") Nickel
4. 0= Without Peg, P= With Peg
5. 0= Without Pick & Place Pad, P= With Pick & Place Pad
6. Packing: R=Tape & Reel ,T= Tube Packaged
7. Other Option: 0=LCP (Standard), M=Nylon 9T

* The one with both Peg and Pad is with Tape & Reel packing only.

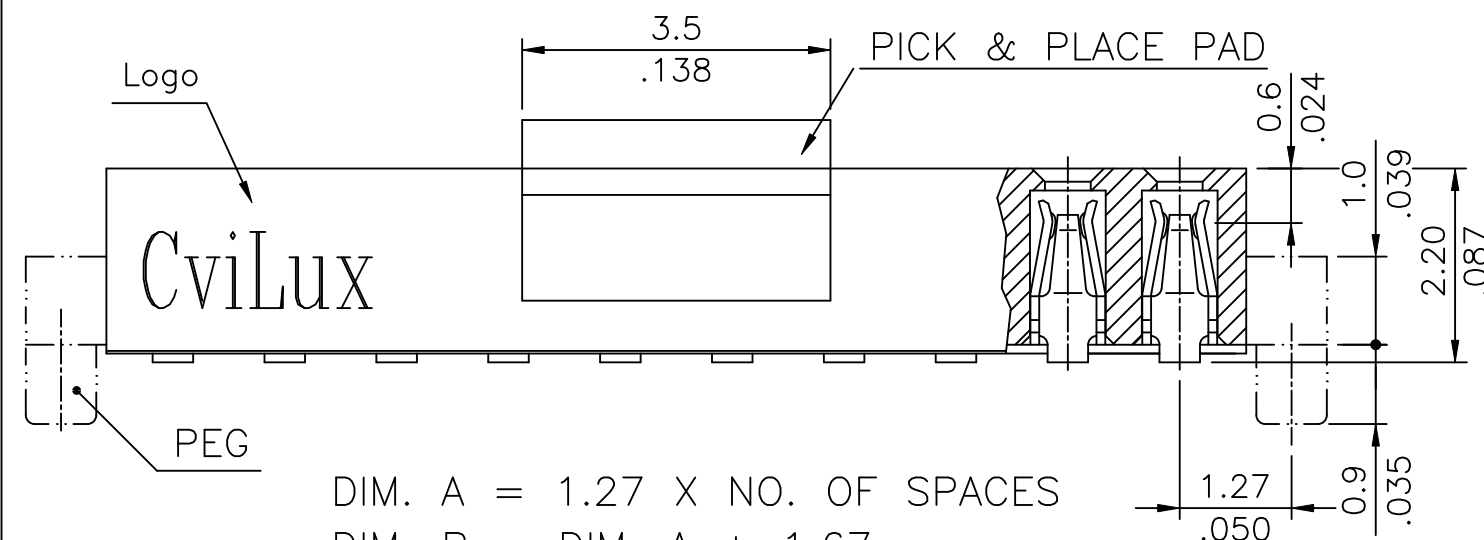
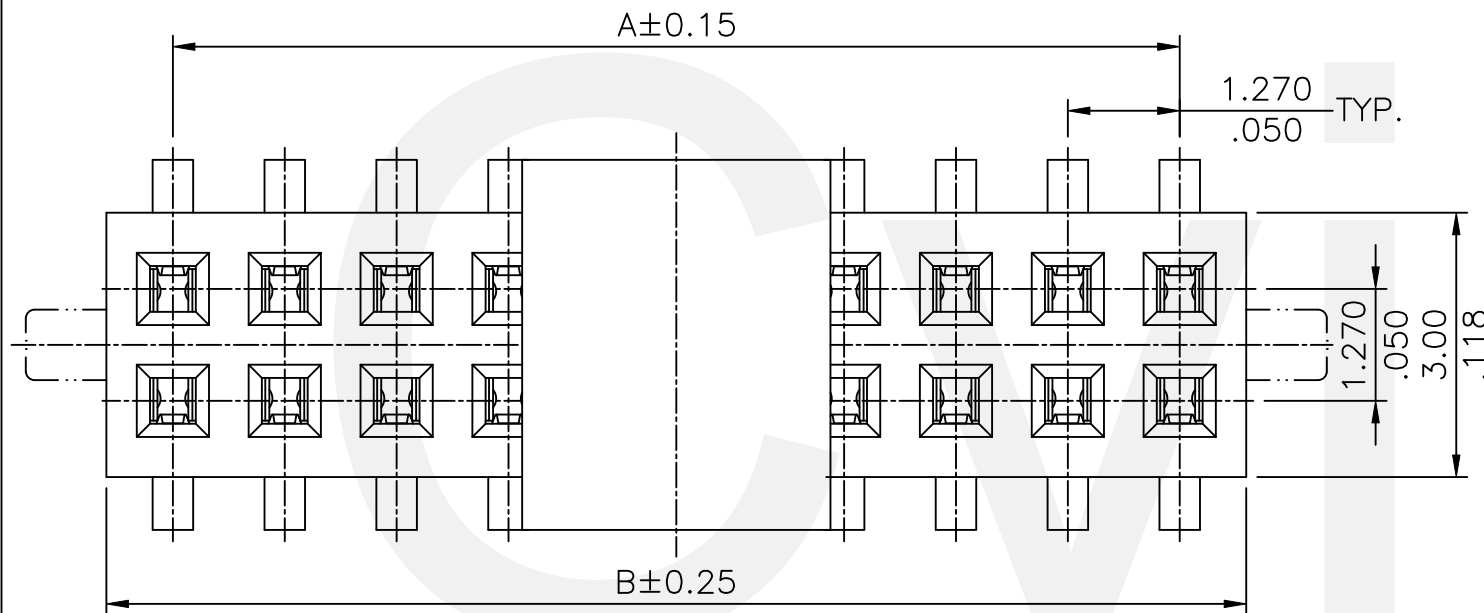

DIM. A = 1.27 X NO. OF SPACES
 DIM. B = DIM. A + 1.67

* AVAILABLE IN 4 THROUGH 48 CIRCUITS

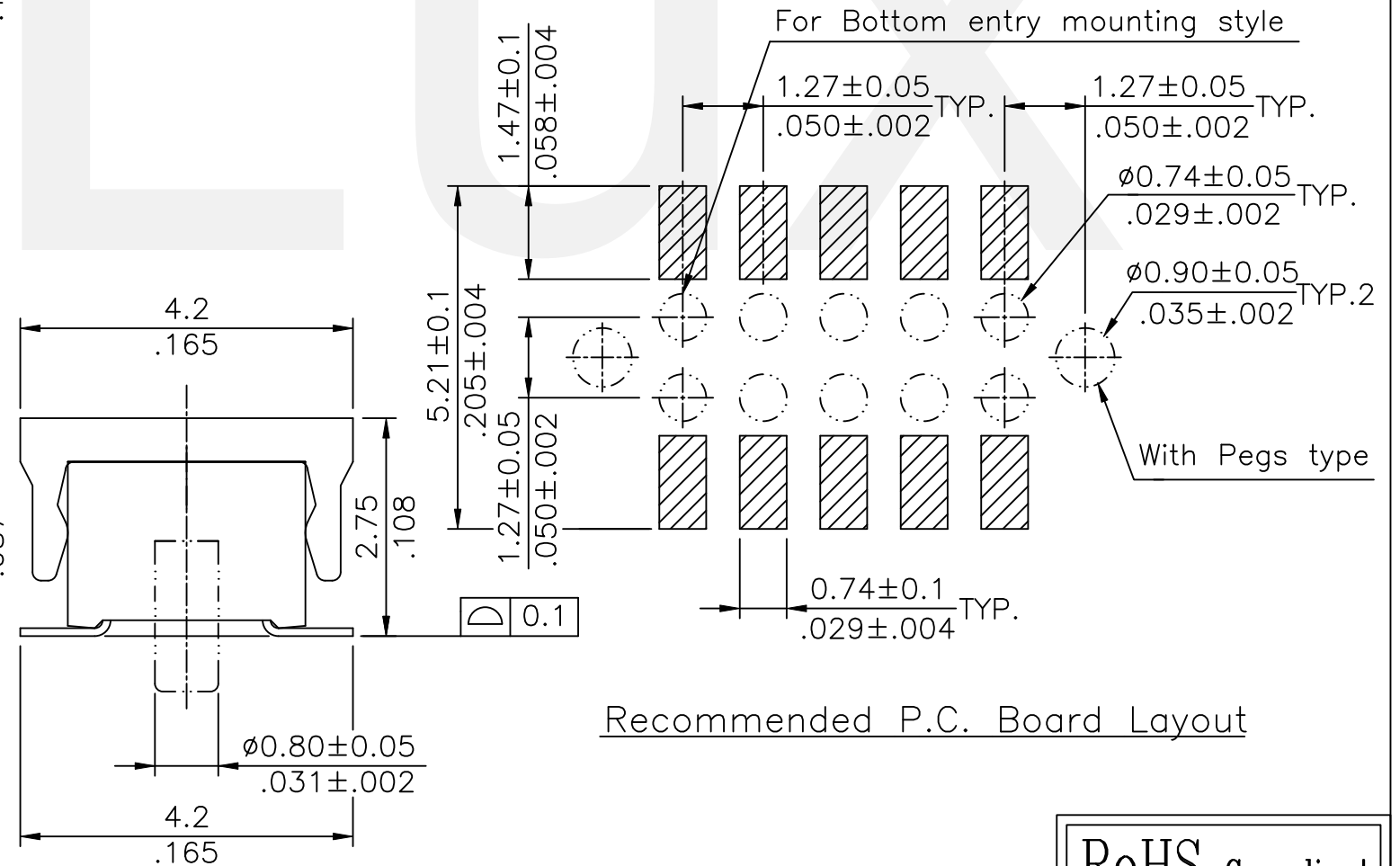

Recommended P.C. Board Layout

RoHS Compliant

△10	Jack	5/21-24'	ECNT124136		DATE	UNIT: mm / inch	TITLE: LOW PROFILE 1.27*1.27MM SMT TYPE SOCKET	 瀚荃股份有限公司 CviLux Corporation
△9	Karen	9/21-09'	ECN09465	DRAWN BY:	Jack	5/21-24'	MATERIAL:	
△8	Sun	9/30-08'	ECN08113-1/ECN08475	ENGINEER:	Sun	5/21-24'		
△7	Sandy	5/28-07'	ECN07188/ECR07023-1	CHECKED BY:	Eisley	5/21-24'	FINISH:	
SYM	NAME	DATE	REVISIONS	APPROVED BY:	Eisley	5/21-24'		

CviLux Corp
 2024/05/27
 ISSUED

DRAWING NO.	CB5001SM	PART NO.	CB50*****
SCALE	8 / 1	SHEET	1 OF 2

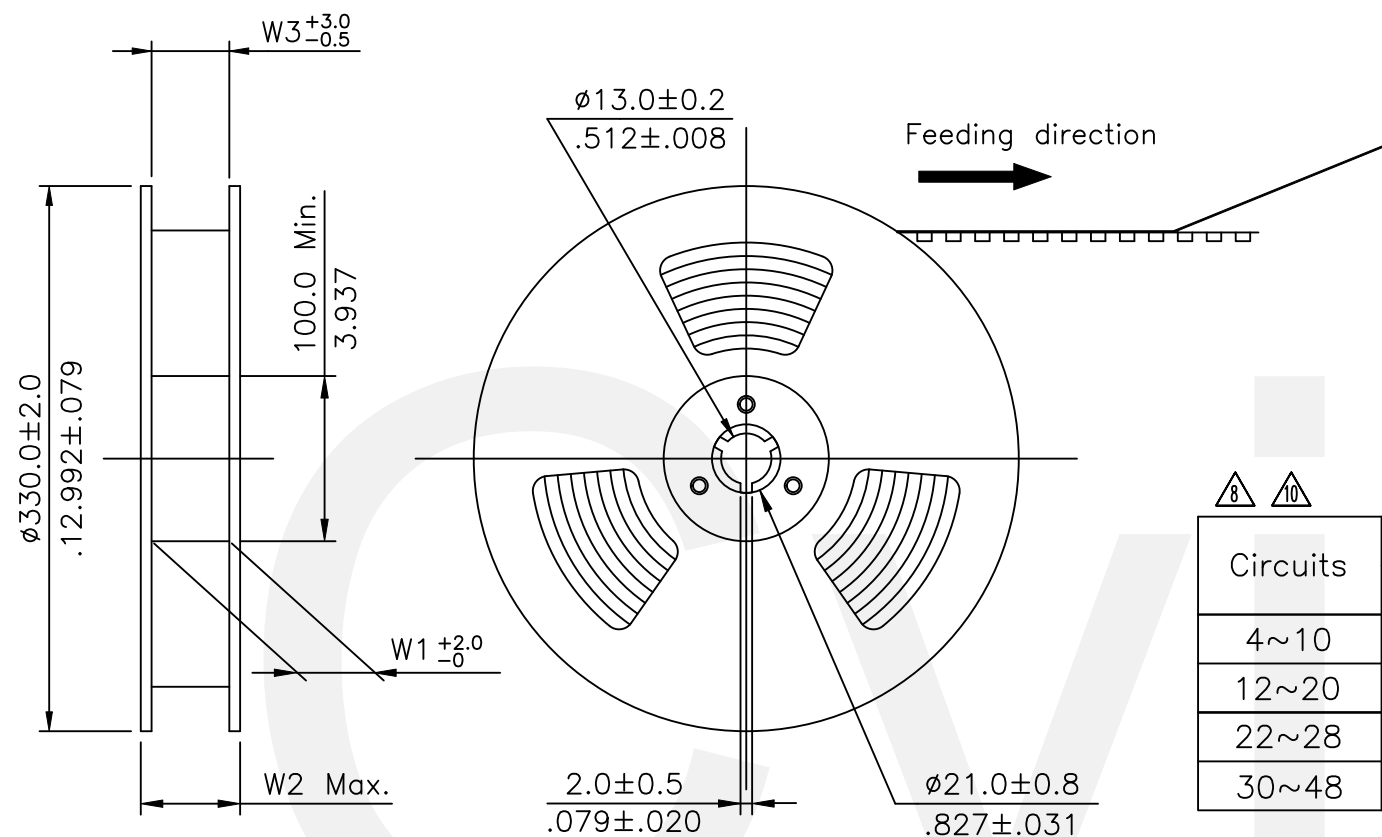

NOTE :

- * Reel Material : HIPS
- ⚠ * Carrier Material : Transparent Conductive Polystyrene Alloy
- * Cover Tape Material : Polyester
- * Cover Tape Peel Strength : 0.1N – 1.3N
- * Carrier camber is within 1mm in 250mm
- * All dimensions meet EIA-481-B requirements.
- * Quantity : 2000 PCS/Reel

Circuits	Dimension					Packing (Reel/Carton)
	E	F	W1	W2	W3	
4~10	16.00(.630)	7.50(.295)	16.5(.650)	22.5(.886)	16.5(.650)	11
12~20	24.00(.945)	11.50(.453)	24.5(.965)	30.5(1.201)	24.5(.965)	9
22~28	32.0(1.260)	28.40(1.118)	32.5(1.280)	38.5(1.516)	32.5(1.280)	7
30~48	44.0(1.732)	40.40(1.596)	44.5(1.752)	50.5(1.988)	44.5(1.752)	5

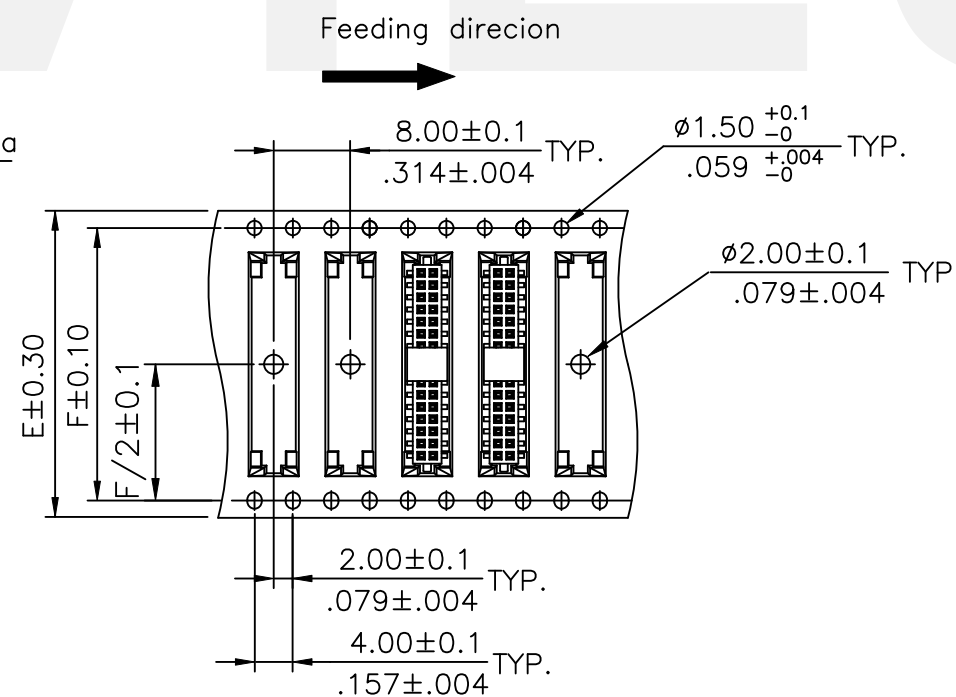
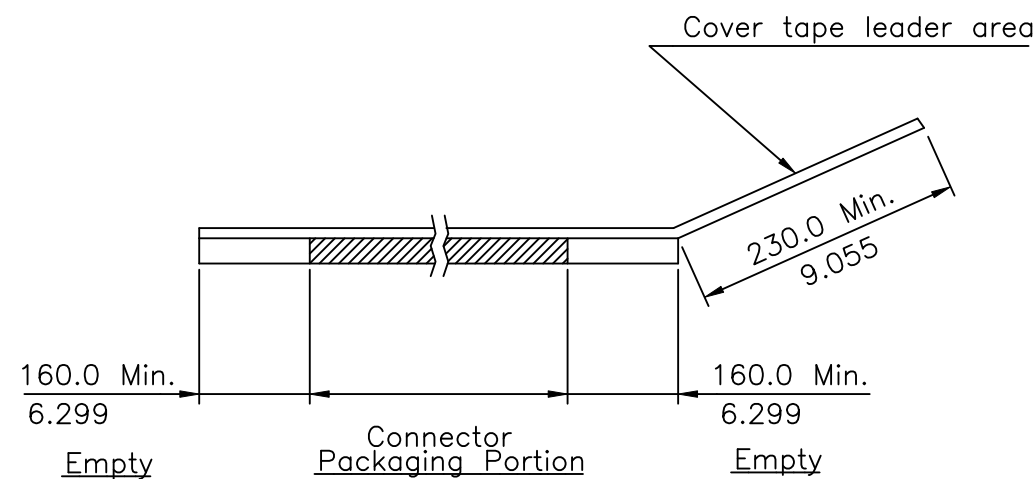

WIDTH : 32,44,56 mm Carrier

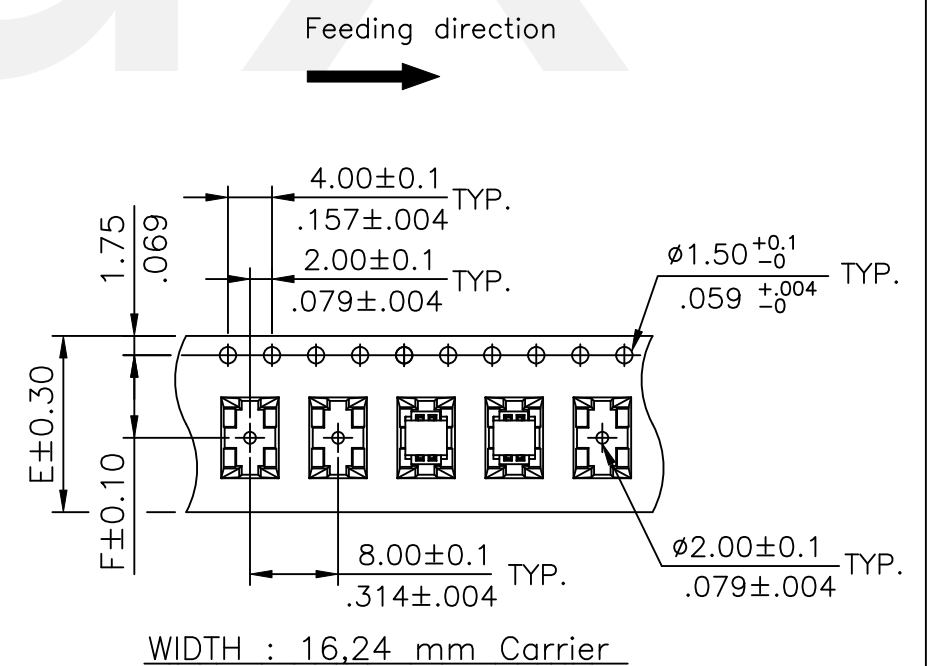

WIDTH : 16,24 mm Carrier

RoHS Compliant

10	Jack	5/21-24'	ECNT124136		DATE	UNIT: mm / inch	TITLE: LOW PROFILE 1.27*1.27MM SMT TYPE SOCKET	瀚荃股份有限公司 CviLux Corporation	
9	Karen	9/21-09'	ECN09465	DRAWN BY: Jack	5/21-24'	TOLERANCE UNLESS OTHERWISE SPECIFIED	MATERIAL:		
8	Sun	9/30-08'	ECN08113-1/ECN08475	ENGINEER: Sun	5/21-24'	.X ± X' ± 1'	FINISH:	DRAWING NO. CB5001SM	PART NO. CB50*****
7	Sandy	5/28-07'	ECN07188/ECR07023-1	CHECKED BY: Eisley	5/21-24'	.XX ± .X' ±		SCALE	SHEET 2 OF 2
SYM	NAME	DATE	REVISIONS	APPROVED BY: Eisley	5/21-24'	.XXX ± .XX' ±			

