

Click to
ORDER
samples

AM1LS-LPZ

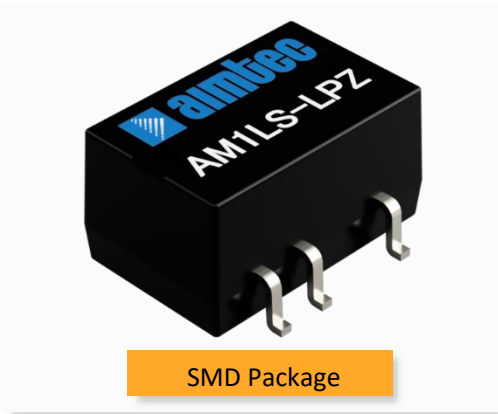

The AM1LS-LPZ is a 1W SMD DC/DC converter that offers great cost savings thanks to an improved manufacturing process. It also features excellent reliability and performance while offering a standard input voltage range of 3.3-24VDC as well as an output voltage of 3.3-24V. This compact SMD design will surely benefit your new system design.

This new series offers great operating temperatures, from -40 to 105°C with full power up to 85°C. Also, an isolation of 1500VDC & 3000VDC for improved reliability and system safety as well as a great 3,500,000h MTBF come standard.

The AM1LS-LPZ is suitable for instrumentation, industrial controls, industrial applications, communication and IoT applications.

Features

- High I/O Isolation 1500VDC & 3000VDC
- Continuous Short circuit protection
- Operating Temp: -40 °C to +105 °C
- Low profile case height: 7.05mm
- Compact footprint and high-power Density
- Efficiency up to 88%
- Unregulated output



Summary

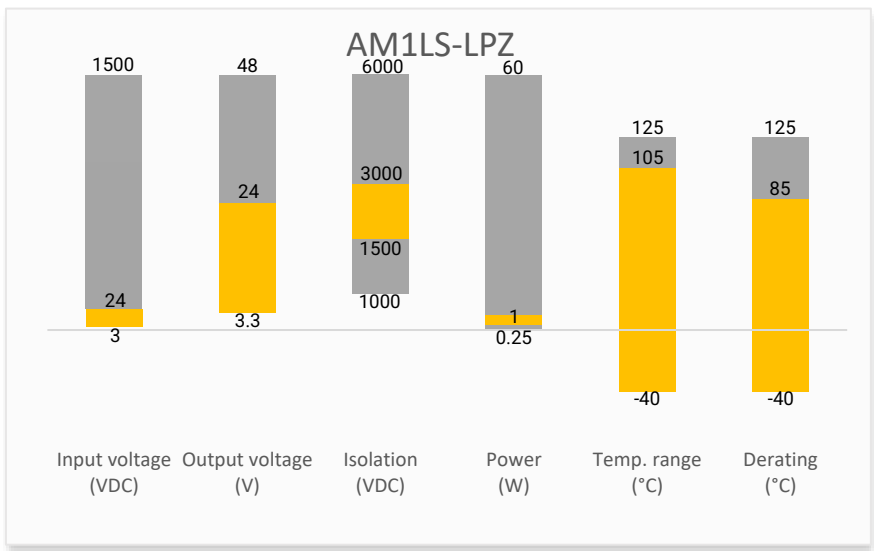

Training



Product Training Video
(click to open)

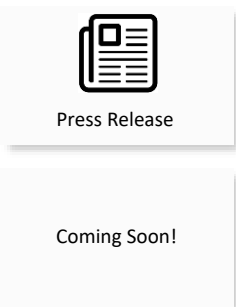

Application Notes

Applications



IoT

Industrial

Telecom

Portable Equipment

Models & Specifications



Single Output

Model	Input Voltage (VDC)	Output Voltage (VDC)	Input Current Full No load Typ. (mA)	Output Current max min (mA)	Isolation (VDC)	Maximum capacitive Load (μF)	Efficiency Typ. (%)
AM1LS-0303SLPZ	3.3 (2.97-3.63)	3.3	370 / 3	303 / 0	1500	3000	80
AM1LS-0305SLPZ	3.3 (2.97-3.63)	5	370 / 3	200 / 0	1500	3000	82
AM1LS-0309SLPZ	3.3 (2.97-3.63)	9	370 / 3	111 / 0	1500	1200	83
AM1LS-0312SLPZ	3.3 (2.97-3.63)	12	370 / 3	84 / 0	1500	820	84
AM1LS-0315SLPZ	3.3 (2.97-3.63)	15	370 / 3	67 / 0	1500	680	84
AM1LS-0324SLPZ	3.3 (2.97-3.63)	24	370 / 3	42 / 0	1500	330	84
AM1LS-0503SLPZ	5 (4.5-5.5)	3.3	230 / 3	303 / 0	1500	3000	82
AM1LS-0505SLPZ	5 (4.5-5.5)	5	230 / 3	200 / 0	1500	3000	85
AM1LS-0509SLPZ	5 (4.5-5.5)	9	230 / 3	111 / 0	1500	1200	86
AM1LS-0512SLPZ	5 (4.5-5.5)	12	230 / 3	84 / 0	1500	820	86
AM1LS-0515SLPZ	5 (4.5-5.5)	15	230 / 3	67 / 0	1500	680	86
AM1LS-0524SLPZ	5 (4.5-5.5)	24	230 / 3	42 / 0	1500	330	87
AM1LS-1203SLPZ	12 (10.8-13.2)	3.3	99 / 3	303 / 0	1500	3000	82
AM1LS-1205SLPZ	12 (10.8-13.2)	5	99 / 3	200 / 0	1500	3000	85
AM1LS-1209SLPZ	12 (10.8-13.2)	9	99 / 3	111 / 0	1500	1200	86
AM1LS-1212SLPZ	12 (10.8-13.2)	12	99 / 3	84 / 0	1500	820	86
AM1LS-1215SLPZ	12 (10.8-13.2)	15	99 / 3	67 / 0	1500	680	86
AM1LS-1224SLPZ	12 (10.8-13.2)	24	99 / 3	42 / 0	1500	330	88
AM1LS-1505SLPZ	15 (13.5-16.5)	5	99 / 3	200 / 0	1500	3000	86
AM1LS-1512SLPZ	15 (13.5-16.5)	12	99 / 3	84 / 0	1500	820	87
AM1LS-1515SLPZ	15 (13.5-16.5)	15	99 / 3	67 / 0	1500	680	88
AM1LS-2403SLPZ	24 (21.6-26.4)	3.3	51 / 3	303 / 0	1500	3000	82
AM1LS-2405SLPZ	24 (21.6-26.4)	5	51 / 3	200 / 0	1500	3000	85
AM1LS-2409SLPZ	24 (21.6-26.4)	9	51 / 3	111 / 0	1500	1200	86
AM1LS-2412SLPZ	24 (21.6-26.4)	12	51 / 3	84 / 0	1500	820	87
AM1LS-2415SLPZ	24 (21.6-26.4)	15	51 / 3	67 / 0	1500	680	87
AM1LS-2424SLPZ	24 (21.6-26.4)	24	51 / 3	42 / 0	1500	330	88
AM1LS-0303SH30LPZ	3.3 (2.97-3.63)	3.3	370 / 3	303 / 30	3000	3000	80
AM1LS-0305SH30LPZ	3.3 (2.97-3.63)	5	370 / 3	200 / 20	3000	3000	82
AM1LS-0309SH30LPZ	3.3 (2.97-3.63)	9	370 / 3	111 / 11	3000	1200	83
AM1LS-0312SH30LPZ	3.3 (2.97-3.63)	12	370 / 3	83 / 8	3000	820	84
AM1LS-0503SH30LPZ	5 (4.5-5.5)	3.3	230 / 3	303 / 30	3000	3000	82
AM1LS-0505SH30LPZ	5 (4.5-5.5)	5	230 / 3	200 / 20	3000	3000	85
AM1LS-0509SH30LPZ	5 (4.5-5.5)	9	230 / 3	111 / 12	3000	1200	86
AM1LS-0512SH30LPZ	5 (4.5-5.5)	12	230 / 3	84 / 9	3000	820	86
AM1LS-0515SH30LPZ	5 (4.5-5.5)	15	230 / 3	67 / 7	3000	680	86
AM1LS-0524SH30LPZ	5 (4.5-5.5)	24	230 / 3	42 / 4	3000	330	87
AM1LS-1203SH30LPZ	12 (10.8-13.2)	3.3	99 / 3	303 / 30	3000	3000	82
AM1LS-1205SH30LPZ	12 (10.8-13.2)	5	99 / 3	200 / 20	3000	3000	85
AM1LS-1209SH30LPZ	12 (10.8-13.2)	9	99 / 3	111 / 12	3000	1200	86
AM1LS-1212SH30LPZ	12 (10.8-13.2)	12	99 / 3	84 / 9	3000	820	86
AM1LS-1215SH30LPZ	12 (10.8-13.2)	15	99 / 3	67 / 7	3000	680	86
AM1LS-1224SH30LPZ	12 (10.8-13.2)	24	99 / 3	42 / 4	3000	330	88

AM1LS-1505SH30LPZ	15 (13.5-16.5)	5	99 / 3	200 / 20	3000	3000	86
AM1LS-1512SH30LPZ	15 (13.5-16.5)	12	99 / 3	84 / 9	3000	820	87
AM1LS-1515SH30LPZ	15 (13.5-16.5)	15	99 / 3	67 / 7	3000	680	88
AM1LS-2403SH30LPZ	24 (21.6-26.4)	3.3	51 / 3	303 / 30	3000	3000	82
AM1LS-2405SH30LPZ	24 (21.6-26.4)	5	51 / 3	200 / 20	3000	3000	85
AM1LS-2409SH30LPZ	24 (21.6-26.4)	9	51 / 3	111 / 12	3000	1200	86
AM1LS-2412SH30LPZ	24 (21.6-26.4)	12	51 / 3	84 / 9	3000	820	87
AM1LS-2415SH30LPZ	24 (21.6-26.4)	15	51 / 3	67 / 7	3000	680	87
AM1LS-2424SH30LPZ	24 (21.6-26.4)	24	51 / 3	42 / 4	3000	330	88

Note: Use suffix "TR" for tape & reel packing (ex. AM1LS-0303SLPZTR)

Dual Output							
Model	Input Voltage (VDC)	Output Voltage (VDC)	Input Current Full No load max (mA)	Output Current max min (mA)	Isolation (VDC)	Maximum capacitive Load (μF)	Efficiency Typ. (%)
AM1LS-0303DLPZ	3.3 (2.97-3.63)	±3.3	370 / 10	±152/±15	1500	±1200	77
AM1LS-0305DLPZ	3.3 (2.97-3.63)	±5	370 / 10	±100/±10	1500	±1200	82
AM1LS-0309DLPZ	3.3 (2.97-3.63)	±9	370 / 10	±56/±5	1500	±470	82
AM1LS-0312DLPZ	3.3 (2.97-3.63)	±12	370 / 10	±42/±5	1500	±220	82
AM1LS-0315DLPZ	3.3 (2.97-3.63)	±15	370 / 10	±34/±4	1500	±220	82
AM1LS-0324DLPZ	3.3 (2.97-3.63)	±24	370 / 10	±21/±2	1500	±100	84
AM1LS-0503DLPZ	5 (4.5-5.5)	±3.3	240 / 10	±152/±15	1500	±1200	74
AM1LS-0505DLPZ	5 (4.5-5.5)	±5	240 / 10	±100/±10	1500	±1200	82
AM1LS-0509DLPZ	5 (4.5-5.5)	±9	240 / 10	±56/±6	1500	±470	83
AM1LS-0512DLPZ	5 (4.5-5.5)	±12	240 / 10	±42/±5	1500	±220	83
AM1LS-0515DLPZ	5 (4.5-5.5)	±15	240 / 10	±34/±4	1500	±220	83
AM1LS-0524DLPZ	5 (4.5-5.5)	±24	240 / 10	±21/±3	1500	±100	85
AM1LS-1205DLPZ	12 (10.8-13.2)	±5	108 / 10	±100/±10	1500	±1200	82
AM1LS-1207DLPZ	12 (10.8-13.2)	±7.5	108 / 10	±67/±7	1500	±470	82
AM1LS-1209DLPZ	12 (10.8-13.2)	±9	108 / 10	±56/±6	1500	±470	83
AM1LS-1212DLPZ	12 (10.8-13.2)	±12	108 / 10	±42/±5	1500	±220	83
AM1LS-1215DLPZ	12 (10.8-13.2)	±15	108 / 10	±34/±4	1500	±220	83
AM1LS-1224DLPZ	12 (10.8-13.2)	±24	108 / 10	±21/±3	1500	±100	85
AM1LS-1515DLPZ	15 (13.5-16.5)	±15	108 / 10	±34/±4	1500	±220	83
AM1LS-2405DLPZ	24 (21.6-26.4)	±5	51 / 10	±100/±10	1500	±1200	82
AM1LS-2409DLPZ	24 (21.6-26.4)	±9	51 / 10	±56/±6	1500	±470	83
AM1LS-2412DLPZ	24 (21.6-26.4)	±12	51 / 10	±42/±5	1500	±220	83
AM1LS-2415DLPZ	24 (21.6-26.4)	±15	51 / 10	±34/±4	1500	±220	83
AM1LS-2424DLPZ	24 (21.6-26.4)	±24	51 / 10	±21/±3	1500	±100	85
AM1LS-0303DH30LPZ	3.3 (2.97-3.63)	±3.3	370 / 10	±152/±15	3000	±1200	77
AM1LS-0305DH30LPZ	3.3 (2.97-3.63)	±5	370 / 10	±100/±10	3000	±1200	82
AM1LS-0309DH30LPZ	3.3 (2.97-3.63)	±9	370 / 10	±56/±5	3000	±470	82
AM1LS-0312DH30LPZ	3.3 (2.97-3.63)	±12	370 / 10	±42/±5	3000	±220	82
AM1LS-0315DH30LPZ	3.3 (2.97-3.63)	±15	370 / 10	±34/±4	3000	±220	82
AM1LS-0324DH30LPZ	3.3 (2.97-3.63)	±24	370 / 10	±21/±2	3000	±100	84
AM1LS-0503DH30LPZ	5 (4.5-5.5)	±3.3	370 / 10	±152/±15	3000	±1200	74
AM1LS-0505DH30LPZ	5 (4.5-5.5)	±5	240 / 10	±100/±10	3000	±1200	82
AM1LS-0509DH30LPZ	5 (4.5-5.5)	±9	240 / 10	±56/±5	3000	±470	83
AM1LS-0512DH30LPZ	5 (4.5-5.5)	±12	240 / 10	±42/±5	3000	±220	83
AM1LS-0515DH30LPZ	5 (4.5-5.5)	±15	240 / 10	±34/±4	3000	±220	83

AM1LS-0524DH30LPZ	5 (4.5-5.5)	±24	240 / 10	±21/±3	3000	±100	85
AM1LS-1203DH30LPZ	12 (10.8-13.2)	±3.3	108 / 10	±100/±10	3000	±1200	82
AM1LS-1209DH30LPZ	12 (10.8-13.2)	±9	108 / 10	±56/±6	3000	±470	83
AM1LS-1212DH30LPZ	12 (10.8-13.2)	±12	108 / 10	±42/±5	3000	±220	83
AM1LS-1215DH30LPZ	12 (10.8-13.2)	±15	108 / 10	±34/±4	3000	±220	83
AM1LS-1224DH30LPZ	12 (10.8-13.2)	±24	108 / 10	±21/±3	3000	±100	85
AM1LS-1515DH30LPZ	15 (13.5-16.5)	±15	108 / 10	±34/±4	3000	±220	83
AM1LS-2405DH30LPZ	24 (21.6-26.4)	±5	51 / 10	±100/±10	3000	±1200	82
AM1LS-2409DH30LPZ	24 (21.6-26.4)	±9	51 / 10	±56/±6	3000	±470	83
AM1LS-2412DH30LPZ	24 (21.6-26.4)	±12	51 / 10	±42/±5	3000	±220	83
AM1LS-2415DH30LPZ	24 (21.6-26.4)	±15	51 / 10	±34/±4	3000	±220	83
AM1LS-2424DH30LPZ	24 (21.6-26.4)	±24	51 / 10	±21/±3	3000	±100	85

Note: Use suffix "TR" for tape & reel packing (ex. AM1LS-0303DLPZTR)

Input Specification

Parameters	Conditions	Typical	Maximum	Units
Filter	Capacitor			
Absolute maximum rating	Maximum duration 1s, 3.3Vin models	> -0.7	5	VDC
	Maximum duration 1s, 5Vin models	> -0.7	9	VDC
	Maximum duration 1s, 12Vin models	> -0.7	18	VDC
	Maximum duration 1s, 15Vin models	> -0.7	21	VDC
	Maximum duration 1s, 24Vin models	> -0.7	30	VDC
Input reflected ripple current		15		mA

Isolation Specification

Parameters	Conditions	Typical	Maximum	Units
Tested I/O voltage	60 sec, leakage ≤ 1mA	>1500		VDC
	60 sec, leakage ≤ 1mA for H30 models	>3000		VDC
Resistance	500VDC	>1000		MΩ
Capacitance	100kHz/0.1V	20		pF

Output Specification

Parameters	Conditions	Typical	Maximum	Units
Voltage accuracy	See output voltage tolerance curves	10	16	%
Line regulation	Per 1% Vin change, 3.3Vout models		1.5	%
	Per 1% Vin change, others		1.2	%
Load regulation	10-100% load, 3.3Vout models, Single output	14		%
	10-100% load, 3.3Vout models, Dual output	15		%
	10-100% load, 5Vout models	10		%
	10-100% load, 9Vout models, Single output	9		%
	10-100% load, 9Vout models, Dual output	8		%
	10-100% load, 12Vout models	8		%
	10-100% load, 15Vout models, Single output	7		%
	10-100% load, 15Vout models, Dual output	8		%
	10-100% load, 24Vout models, Single output	6		%
	10-100% load, 24Vout models, Dual output	8		%
Temperature coefficient	Full load	±0.02		%/°C
Ripple & Noise*	Single output models	60	150	mV pk-pk

	Dual output models	30	100	mV pk-pk
Minimum load**		10		%

* Ripple and Noise are measured at 20MHz bandwidth. Please refer to the application note for specific details.

** Operating with less than 10% of rated load will not cause permanent damage to the converters, but the performance data may not fall into the specifications, and reliable operating is not assured.

General Specifications

Parameters	Conditions	Typical	Maximum	Units
Switching frequency	Full load, nominal input	220		KHz
Short circuit protection	Continuous, Auto recovery			
Operating temperature	With derating at 85°C	-40 to +105		°C
Storage temperature		-55 to +125		°C
Maximum Case temperature		130		°C
Reflow soldering temperature	Maximum duration 60s when over 217°C		245	°C
Soldering method	IPC/JEDEC J-STD-020D.1			
Cooling	Free air convection			
Humidity	Non-condensing	>5	95	% RH
Moisture sensitivity level	Level 1			
Vibration	10-150Hz, 5G, 0.75mm. along X, Y and Z			
Case material	Black plastic (flammability to UL 94V-0)			
Weight	Single output models	1.5		g
	Dual output models	1.7		g
Dimensions (L x W x H)	Single output models	0.53 x 0.43 x 0.24 inches (13.50 x 11.00 x 6.05 mm)		
	Dual output models	0.64 x 0.43 x 0.28 inches (16.24 x 11.00 x 7.05 mm)		
MTBF	3 500 000 hrs (MIL-HDBK -217F, t=+25°C) / Full Load			

NOTE: All specifications in this datasheet are measured at an ambient temperature of 25°C, humidity<75%, nominal input voltage and at rated output load unless otherwise specified.

Safety Specifications

Parameters		
Standards	Information technology Equipment	Design to meet UL/IEC/EN 62368-1
	EMC - Conducted and radiated emission	CISPR32 / EN55032, class B with the recommended EMI circuit
	Electrostatic Discharge Immunity	IEC 61000-4-2

Derating

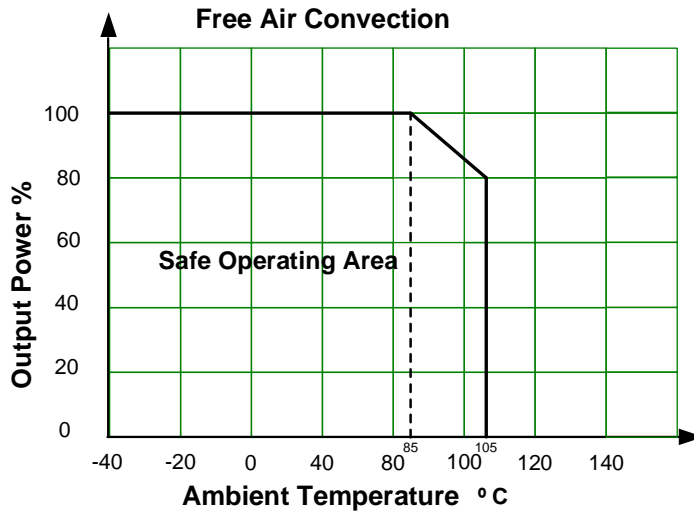

Output voltage tolerance



Single output models

For 3.3V output models

Tolerance Envelope Graph

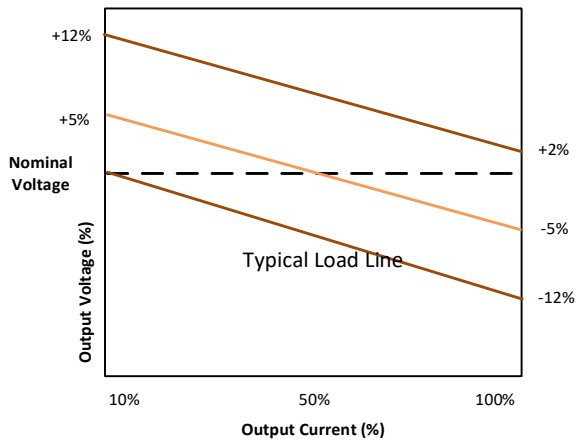

For other output models

Tolerance Envelope Graph

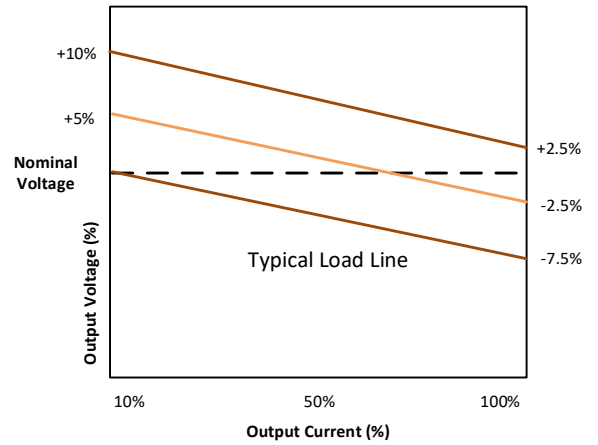

Dual output models

For 5V input, and 3.3V output models

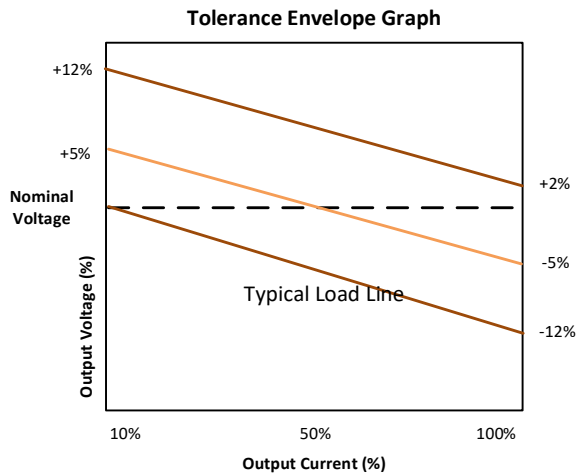

For 3.3V input, and 3.3V output models

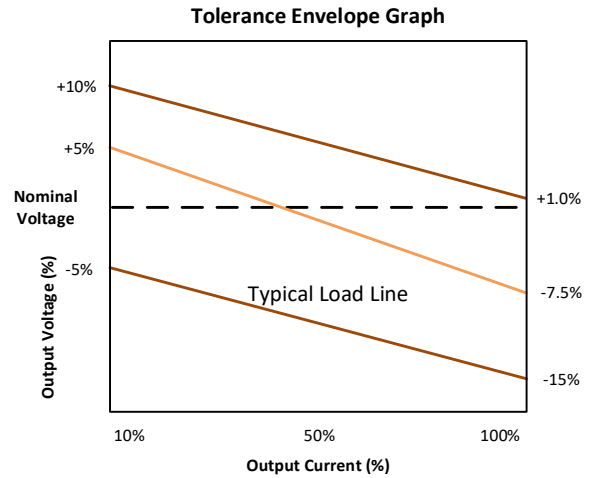

For all other 3.3V input and 5V input models

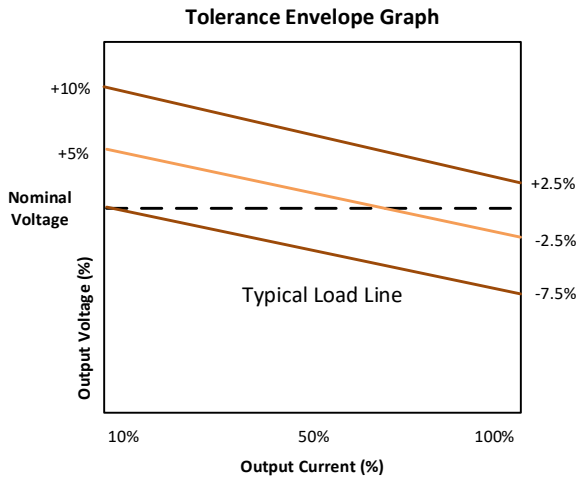

For all 12V input, 15V input, 24V input

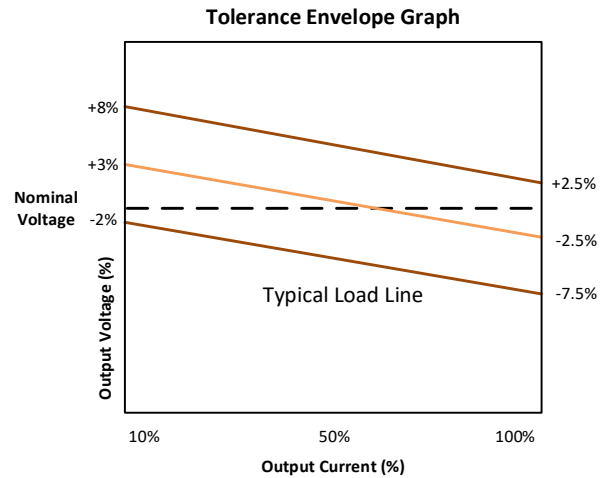

Typical application circuit

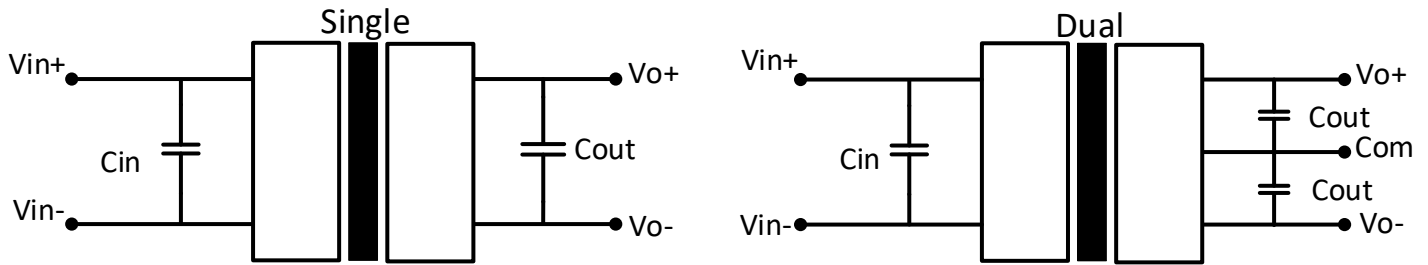

Single output models				Dual output models			
Vin	Cin	Vout	Cout	Vin	Cin	Vout	Cout
3.3	4.7μF/16V	3.3V	10μF/16V	3.3	10μF/16V	±3.3V	10μF/16V
5	4.7μF/16V	5V	10μF/16V	5	4.7μF/16V	±5V	10μF/16V
12	2.2μF/25V	9V	4.7μF/16V	12	2.2μF/25V	±9V	2.2μF/16V
15	2.2μF/25V	12V	2.2μF/25V	15	2.2μF/25V	±12V	2.2μF/25V
24	1μF/50V	15V	1μF/25V	24	1μF/50V	±15V	1μF/25V
-	-	24V	0.47μF/50V	-	-	±24V	1μF/50V

EMI Recommended circuit

Single output models

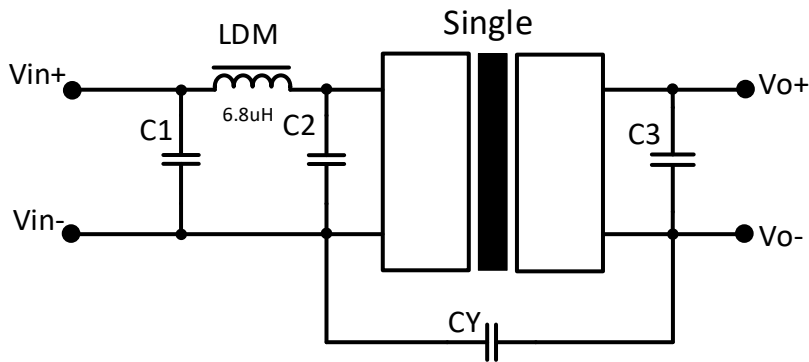

Vin	C1/C2	Vout	CY	C3
All input	4.7μF/50V	All output	270pF/2kVdc	Refer to Cout in typical circuit

Dual output models

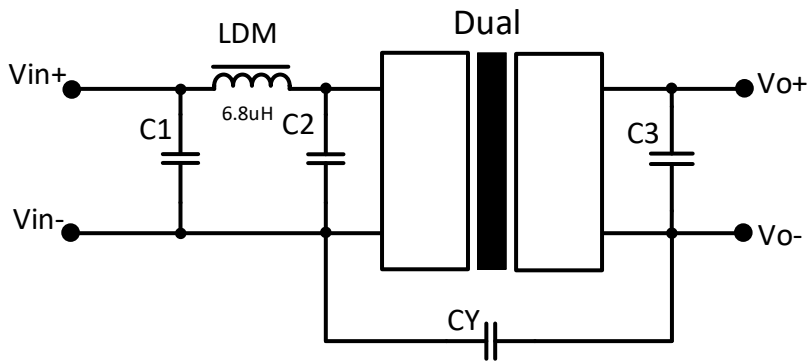

Vin	C1/C2	Vout	CY (3.3~9Vout)	CY(12~24Vout)	C3
All input	4.7 μ F/50V	All output	100pF/4kV	1nF/4kV	Refer to Cout in typical circuit

Dimensions

Single output models

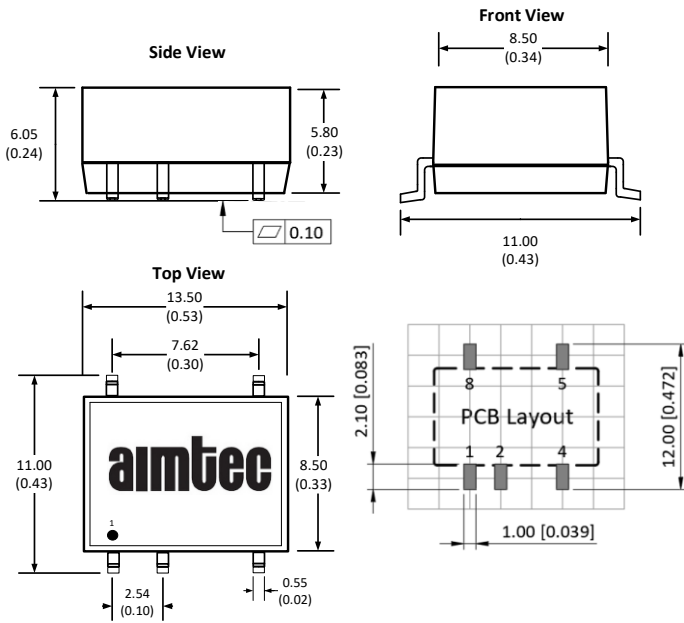

Note:
Unit: mm(inch)
General tolerance: ± 0.50 (0.02)
Pin tolerance: ± 0.1 (0.004)
Footprint grid 2.54 x 2.54 mm

Pin Out Specifications		
Pin	Single	Dual
1	-V Input	-V Input
2	+V Input	+V Input
3	-	-
4	-V Output	Common
5	+V Output	-V Output
6	-	-
7	-	+V Output
8	NC	-
9	-	-
10	-	NC

Dual output models

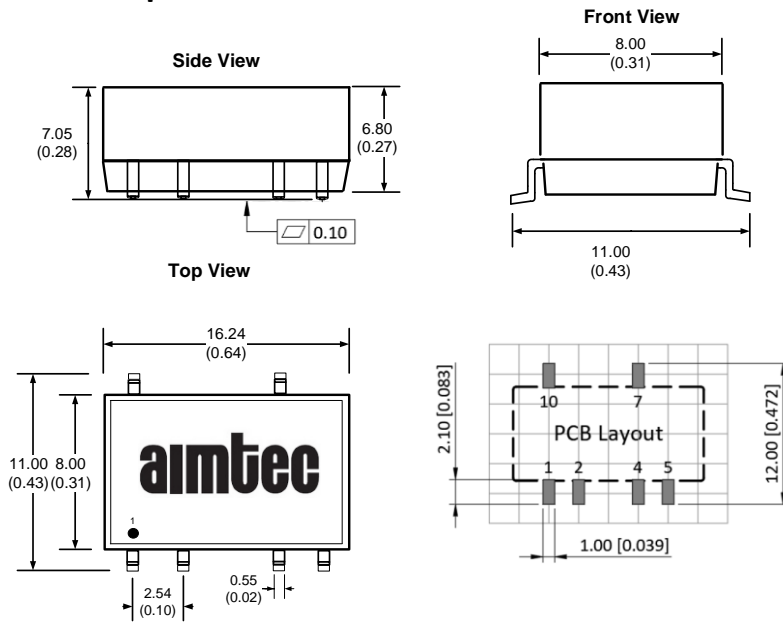

Note:
Unit: mm(inch)
General tolerance: ± 0.25 (0.01)
Pin tolerance: ± 0.1 (0.004)
Footprint grid 2.54 x 2.54 mm

Packing Information

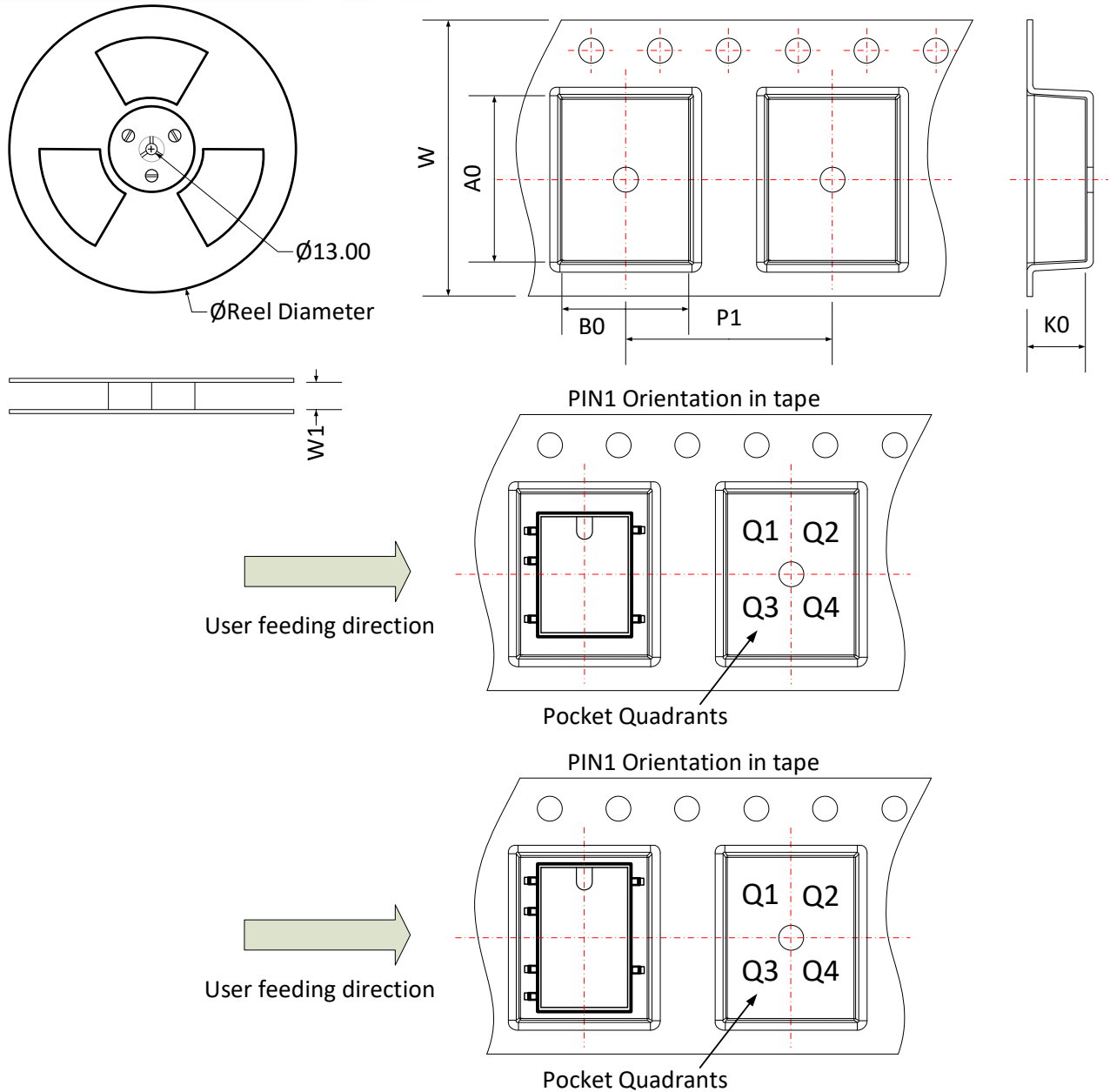

Device	Package Type	Pin	MPQ	Reel Diameter (mm)	Reel Width W1 (mm)	A0	B0	K0	P1	W	P1 Quadrant
AM1LS-LPZ Single output	SMD	5	500	330.0	24.5	13.4	11.7	7.5	16.0	24.0	Q1
AM1LS-LPZ Dual output	SMD	6	500	330.0	24.5	15.64	12.4	7.45	16.0	24.0	Q1

NOTE: 1. Datasheets are updated as needed and as such, specifications are subject to change without notice. Once printed or downloaded, datasheets are no longer controlled by Aimtec; refer to www.aimtec.com for the most current product specifications. **2.** Product labels shown, including safety agency certifications on labels, may vary based on the date manufactured. **3.** Mechanical drawings and specifications are for reference only. **4.** All specifications are measured at an ambient temperature of 25°C, humidity < 75%, nominal input voltage and at rated output load unless otherwise specified. **5.** Aimtec may not have conducted destructive testing or chemical analysis on all internal components and chemicals at the time of publishing this document. CAS numbers and other limited information are considered proprietary and may not be available for release. **6.** This product is not designed for use in critical life support systems, equipment used in hazardous environments, nuclear control systems or other such applications which necessitate specific safety and regulatory standards other than the ones listed in this datasheet. **7.** Warranty is in accordance with Aimtec's standard Terms of Sale available at www.aimtec.com.