

Click to  
**ORDER**  
samples

**AM10GH-LPZ**



Aimtec adds the AM10GH-LPZ 10W series to its SIP8 DC/DC converters family. This new series now increases the power density of our SIP8 line from 9W to 10W.

The AM10GH-LPZ series provide a 4:1 ultrawide input voltage range and comes standard with single regulated output voltages of 3.3, 5, 9, 12, 15 and 24VDC with an I/O isolation of 1500VDC. Thanks to its wide -40°C to +85°C operating temperature range, the AM10GH-LPZ is suitable for applications that include industrial control, grid power, instrumentation and telecommunication. In addition to meeting EN62368 certification, protections for input under-voltage, output short circuit, over-current are also included, increasing the overall safety of your new system design.

**Features**

- Ultra-wide input voltage range: 9-36VDC
- Operating temperature range: -40°C to +85°C
- Efficiency up to 86%
- Input under-voltage protection, output short circuit, over-current protection
- High power density, SIP8 package
- International standard pin-out

**Summary**

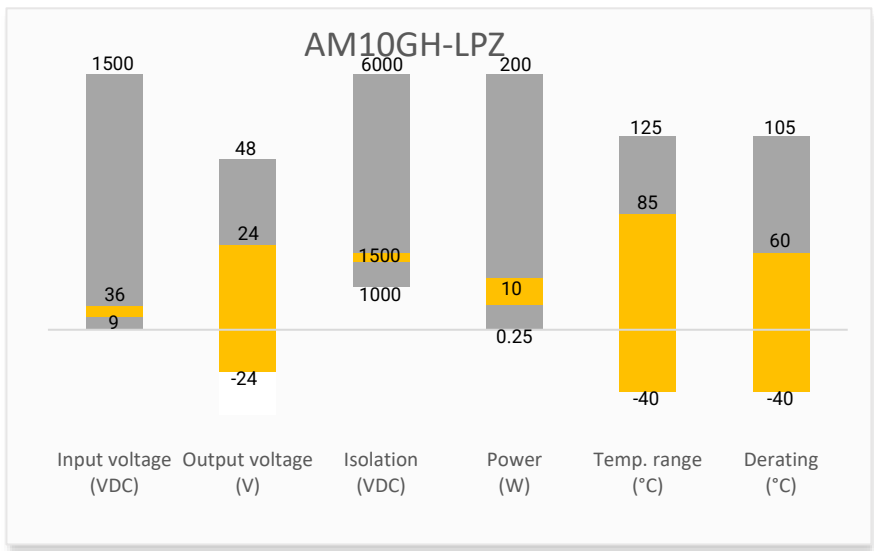

**Training**



Product Training Video  
(click to open)



Press Release

Coming Soon!

Application Notes

**Applications**



## Models & Specifications

### Single Output

Model	Input Voltage (VDC)	Output Voltage (VDC)	Input Current max (mA)	Output Current max (A)	Isolation (VDC)	Maximum capacitive Load ( $\mu$ F)	Efficiency Full Load (Min.) (%)
AM10GH-2403SLPZ	24 (9 - 36)	3.3	474	2.4	1500	2200	82
AM10GH-2405SLPZ	24 (9 - 36)	5	474	2	1500	2200	82
AM10GH-2406SLPZ	24 (9 - 36)	6	474	1.67	1500	1500	84
AM10GH-2409SLPZ	24 (9 - 36)	9	474	1.11	1500	680	86
AM10GH-2410SLPZ	24 (9 - 36)	10	474	1	1500	680	86
AM10GH-2412SLPZ	24 (9 - 36)	12	474	0.83	1500	470	86
AM10GH-2415SLPZ	24 (9 - 36)	15	474	0.67	1500	330	86
AM10GH-2424SLPZ	24 (9 - 36)	24	474	0.42	1500	220	86

### Dual Output

Model	Input Voltage (VDC)	Output Voltage (VDC)	Input Current max (mA)	Output Current max (A)	Isolation (VDC)	Maximum capacitive Load ( $\mu$ F)	Efficiency Full Load (Min.) (%)
AM10GH-2415DLPZ	24 (9 - 36)	$\pm$ 15	474	$\pm$ 0.33	1500	100	86

### Input Specification

Parameters	Conditions	Typical	Maximum	Units
Voltage range	Nominal 24V	9 – 36		VDC
Filter	Capacitor			
No load input current	5Vout model	25		mA
	Others	9		mA
Startup input voltage			9	VDC
Input under-voltage lockout		6.5		VDC
Absolute maximum rating	1 Sec.	$\geq$ -0.7	50	VDC
Input reflected current		50		mA pk-pk
On/Off Control	ON – 3.5 to 12Vdc or open OFF – 0 to 1.2Vdc or connected to “-V Input”, idle current 10mA max.			

Note: The voltage of Ctrl pin is relative to “-V Input” pin .

### Isolation Specification

Parameters	Conditions	Typical	Maximum	Units
Tested I/O voltage	60 sec, < 1mA	1500		VDC
Resistance	500Vdc	>1000		M $\Omega$
Capacitance	Input to output, 100KHz/0.1V	1000		pF

Output Specification				
Parameters	Conditions	Typical	Maximum	Units
Voltage accuracy	0-100% load	±1	±2	%
Line regulation	Full load, main input range	±0.5	±1	%
Load regulation	5-100% load	±0.5	±1	%
Short circuit protection	Continuous, Auto recovery			
Over current protection		160	230	% of Iout
Temperature coefficient	Full load		±0.03	%/°C
Ripple & Noise*	20MHz bandwidth, 5-100% load	75	150	mV pk-pk
Transient recovery time	25% load step change	300	500	µS
Transient response deviation	25% load step change, 3.3/5V Output	±5	±8	%
	25% load step change, Others	±3	±5	%

\* Ripple & noise under 0-5% load is 300mV max. Please refer to the ripple & noise reduction circuit for testing method.

General Specifications				
Parameters	Conditions	Typical	Maximum	Units
Switching frequency*	100% load	500		KHz
Operating temperature	See derating graph	-40 to +85		°C
Storage temperature		-55 to +125		°C
Maximum case temperature			95	°C
Lead temperature	1.5mm from case 10 sec.		300	°C
Cooling	Free air convection			
Humidity	Non-condensing		95	% RH
Case material	Heat resistant black Plastic (flammability to UL 94V-0)			
Weight		4.9		g
Dimensions (L x W x H)	0.87 x 0.37 x 0.47 inches, 22.00 x 9.50 x 12.00mm			
MTBF	> 1 000 000 hrs (MIL-HDBK -217F, t=+25°C) / Full Load			

\*Switching frequency reduces when load under 50%.  
All specifications in this datasheet are measured at an ambient temperature of 25°C, humidity<75%, nominal input voltage and at rated output load unless otherwise specified.

Environmental Specifications	
Parameters	
Vibration	10-150Hz, 5G, 0.75mm, along X, Y and Z

Safety Specifications		
Parameters		
Standards	Information technology Equipment	Design to meet IEC/UL/EN 62368-1
	EMC - Conducted and radiated emission	CISPR32/EN55032 Class B with recommended EMC circuit
	Electrostatic Discharge Immunity	IEC 61000-4-2 Contact ±6KV, Criteria B
	RF, Electromagnetic Field Immunity	IEC 61000-4-3 10V/m, Criteria A
	Electrical Fast Transient/Burst Immunity	IEC 61000-4-4 ±2KV, Criteria B with recommended EMC circuit
	Surge Immunity	IEC 61000-4-5 L-L ±2KV, Criteria B with recommended EMC circuit
	RF, Conducted Disturbance Immunity	IEC 61000-4-6 3Vr.m.s, Criteria A

## Derating



Free Air Convection

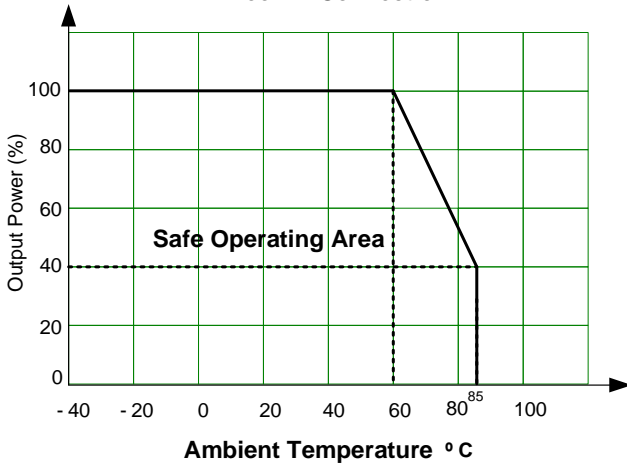

## Typical Application Circuit

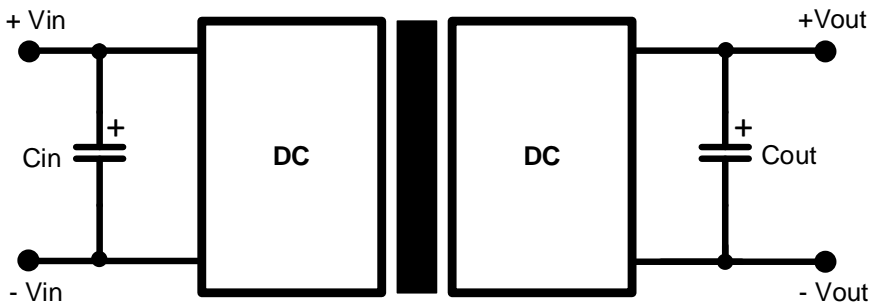

Vout(VDC)	Cin	Cout
3.3, 5, 9	47μF/100V	22μF/50V
12, 15		
24		

## Recommended EMC Circuit

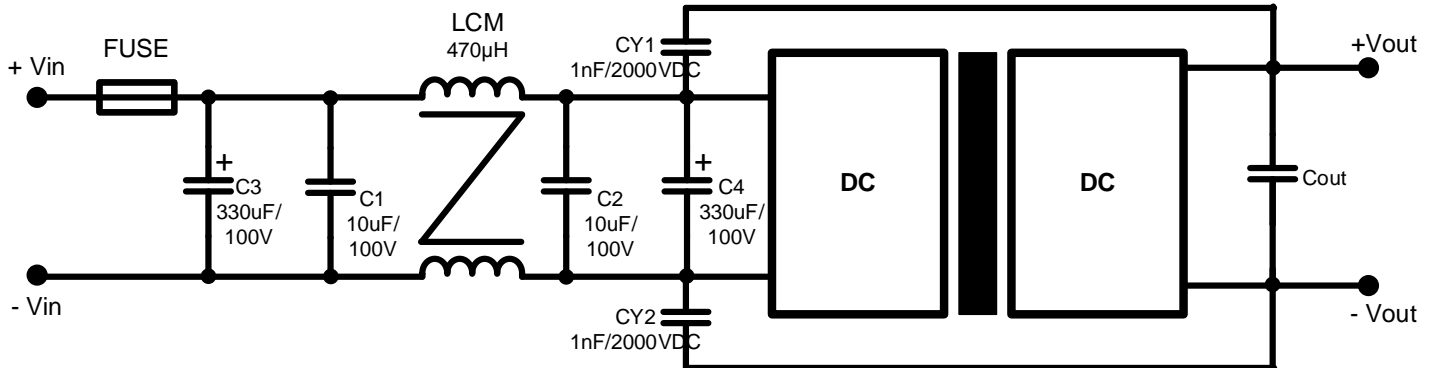

## Dimensions

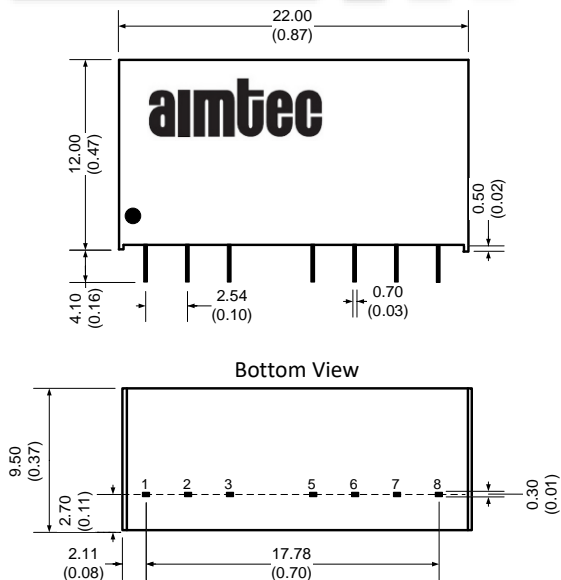

Dimensions mm (inch)  
Case Tolerance  $\pm 0.50$  ( $\pm 0.02$ )  
Pin Diameter  $\pm 0.10$  ( $\pm 0.004$ )

Pin	Single	Dual
1	-V Input	-V Input
2	+V Input	+V Input
3	Ctrl	Ctrl
5	NC	NC
6	+V Output	+V Output
7	-V Output	-V Output
8	NC	-V Output

**NOTE: 1.** Datasheets are updated as needed and as such, specifications are subject to change without notice. Once printed or downloaded, datasheets are no longer controlled by Aimtec; refer to [www.aimtec.com](http://www.aimtec.com) for the most current product specifications. **2.** Product labels shown, including safety agency certifications on labels, may vary based on the date manufactured. **3.** Mechanical drawings and specifications are for reference only. **4.** All specifications are measured at an ambient temperature of 25°C, humidity < 75%, nominal input voltage and at rated output load unless otherwise specified. **5.** Aimtec may not have conducted destructive testing or chemical analysis on all internal components and chemicals at the time of publishing this document. CAS numbers and other limited information are considered proprietary and may not be available for release. **6.** This product is not designed for use in critical life support systems, equipment used in hazardous environments, nuclear control systems or other such applications which necessitate specific safety and regulatory standards other than the ones listed in this datasheet. **7.** Warranty is in accordance with Aimtec's standard Terms of Sale available at [www.aimtec.com](http://www.aimtec.com).