

Click to
ORDER
samples

AMEOFL5-277HALPZ

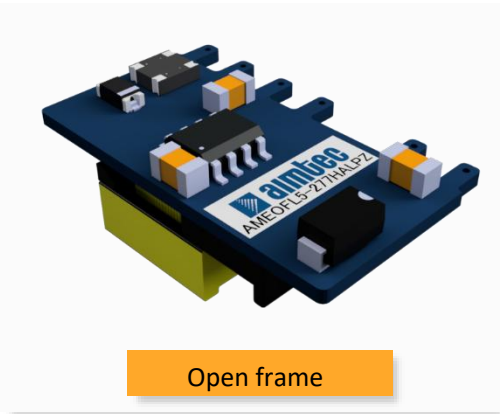

Open frame

The AMEOFL5-277HALPZ series is one of Aimtec’s highly efficient, green 5W AC-DC converter series. It features an ultra-wide input range accepting either AC or DC voltage, high efficiency, compact size in an open-frame, low power consumption and CLASS II reinforced insulation. A variety of EMC external circuits enable this series to meet the needs of multiple industries.

This 5W converter offers great operating temperatures, from -40°C to 85°C and also boasts an isolation of 4000VAC for improved reliability and system safety. Furthermore, a high MTBF of 600,000h, output short circuit protection (OSCP) and an output over-current protection (OCP) come standard with the series.

All models are suitable for industrial control, electric power, instrumentation and smart home applications.

Features



- Universal Input: 85 - 305VAC/100 - 430VDC
- Operating Temp: -40 °C to +85 °C
- High isolation voltage: 4000VAC
- Low ripple & noise, 150mV(p-p), max.
- Output short circuit, over-current
- Open frame package

Summary

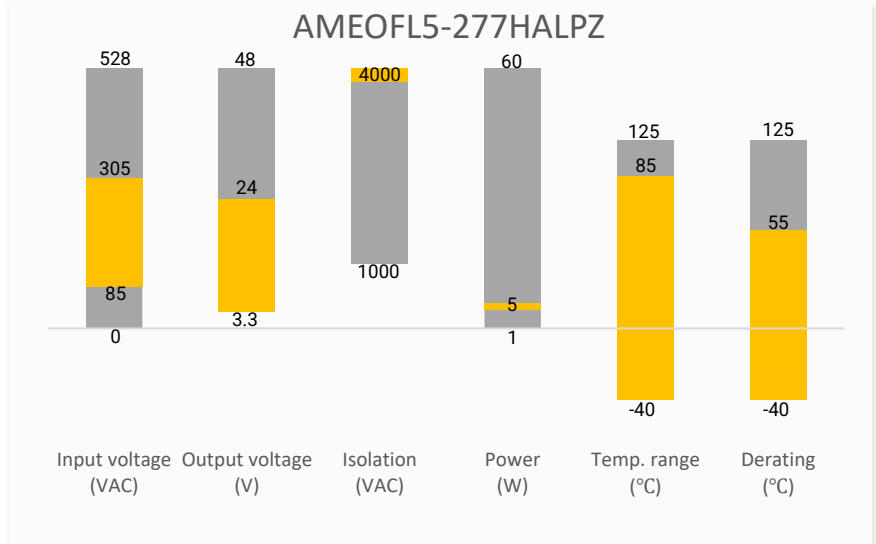

Training

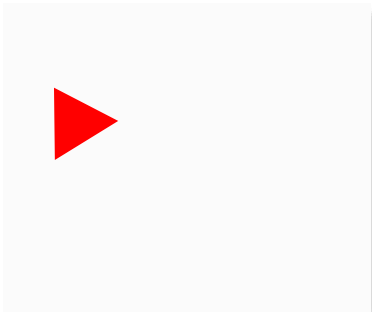

Product Training Video
(click to open)

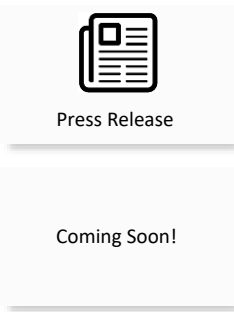

Application Notes

Applications



Power Grid



Industrial



Telecom



Instrumentation

Models & Specifications

Single Output

Model	Input Voltage (VAC/Hz)	Input Voltage (VDC)	Max Output wattage (W)	Output Voltage (V)	Output Current max (A)	Maximum capacitive load (μF)	Efficiency @ 230VAC (%)
AMEOFL5-3S277HALPZ	85~305/47~63	100~430	3.3	3.3	1	2200	68
AMEOFL5-5S277HALPZ	85~305/47~63	100~430	5	5	1	1500	75
AMEOFL5-9S277HALPZ	85~305/47~63	100~430	5	9	0.56	680	76
AMEOFL5-12S277HALPZ	85~305/47~63	100~430	5	12	0.42	470	78
AMEOFL5-15S277HALPZ	85~305/47~63	100~430	5	15	0.34	330	78
AMEOFL5-24S277HALPZ	85~305/47~63	100~430	5	24	0.21	100	80

Input Specifications

Parameters	Conditions	Typical	Maximum	Units
Input current	115VAC		130	mA
	230VAC		90	mA
Inrush current	115VAC	20		A
	230VAC	40		A
External fuse	Slow blow type, required	1		A

Output Specifications

Parameters	Conditions	Typical	Maximum	Units
Voltage accuracy	10% - 100% load	± 5		%
Line regulation	Full load, 3.3Vout	± 2.5		%
	Full load, others	± 1.5		%
Load regulation	10% - 100% load	± 3		%
Ripple & Noise	20MHz bandwidth, 10% - 100% load	80	200	mV p-p

NOTE: The output minimum load is 10%

Isolation Specifications

Parameters	Conditions	Typical	Rated	Units
Tested I/O voltage	60 sec, 5mA max		4000	VAC

General Specifications

Parameters	Conditions	Typical	Maximum	Units
Switching frequency		85		Khz
Safety class	Class II			
Over Current protection	Auto recovery	≥ 110		% of Iout
Short circuit protection	Hiccup, Continuous, Auto recovery			
No-load power consumption	230VAC	0.1	0.15	W
Power derating	+55 °C to +85 °C	1.67		% / °C
	85VAC ~ 100VAC	1.33		% /VAC
	277VAC ~ 305VAC	0.72		% /VAC

Operating temperature		-40 to +85		°C
Storage temperature		-40 to +105		°C
Temperature coefficient		±0.15		% / °C
Cooling	Free air convection			
Storage Humidity			95	% RH
Weight		5.9		g
Dimensions (L x W x H)	1.04 x 0.58 x 0.43 inches (26.40 x 14.8 x 11.00 mm)			
MTBF	> 600 000 hrs (MIL-HDBK -217F, t=+25°C)/Full Load			

NOTE: All specifications in this datasheet are measured at an ambient temperature of 25°C, humidity<75%, nominal input voltage and at rated output load unless otherwise specified.

Safety Specifications

Parameters		
Standards	Designed to meet IEC/EN60335-1, IEC/EN61558-1, IEC/EN61558-2-16, UL/IEC/EN62368-1	
	EMC - Conducted and radiated emission	CISPR32 / EN55032, Class B (With EMI class B recommended circuit)
	Electrostatic Discharge Immunity	IEC 6300-4-2 Contact ±6KV, Criteria B
	RF, Electromagnetic Field Immunity	IEC 6300-4-3 10V/m, Criteria A
	Electrical Fast Transient/Burst Immunity	IEC 6300-4-4 ±2KV, Criteria B (With EMS Class III recommended circuit) IEC 6300-4-4 ±4KV, Criteria B (With EMS Class IV recommended circuit)
	Surge Immunity	IEC 6300-4-5 L-L ±1KV, Criteria B (With EMS Class III recommended circuit) IEC 6300-4-5 L-L ±2KV, Criteria B (With EMS Class IV recommended circuit)
	RF, Conducted Disturbance Immunity	IEC 6300-4-6 10Vr.m.s, Criteria A
	Voltage dips, Short Interruptions Immunity	IEC 6300-4-11 0%, 70%, Criteria B

Derating

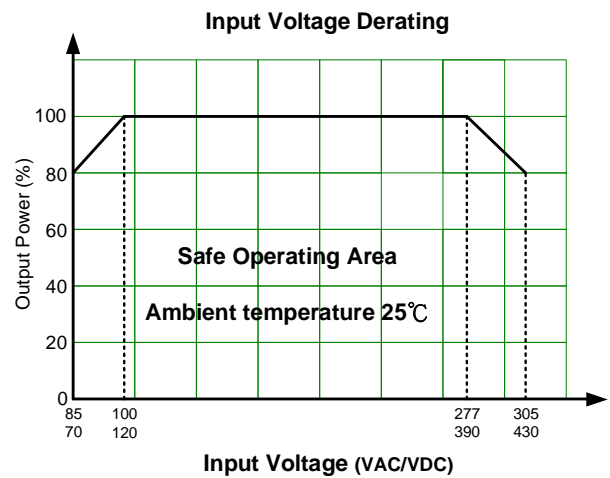
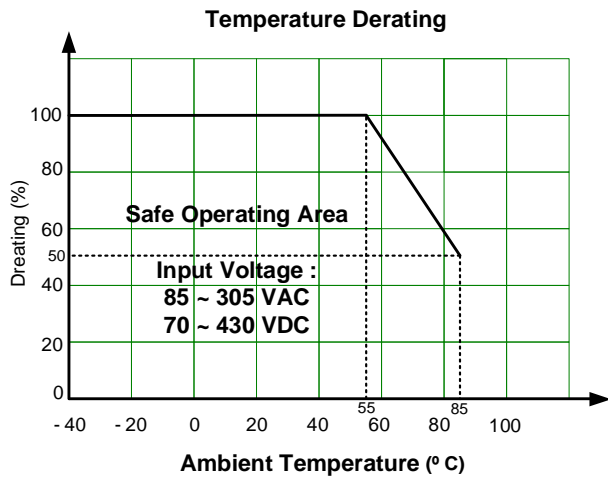

Dimensions

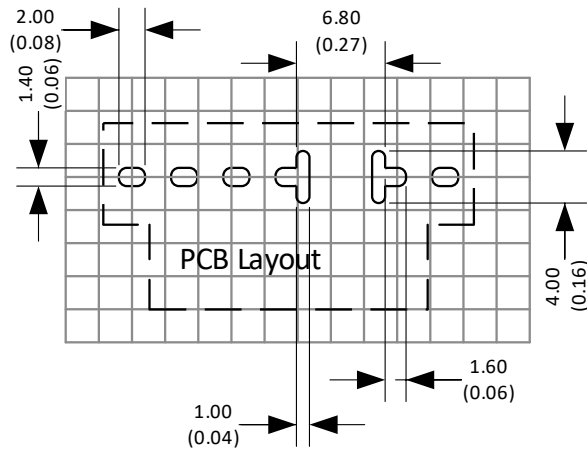
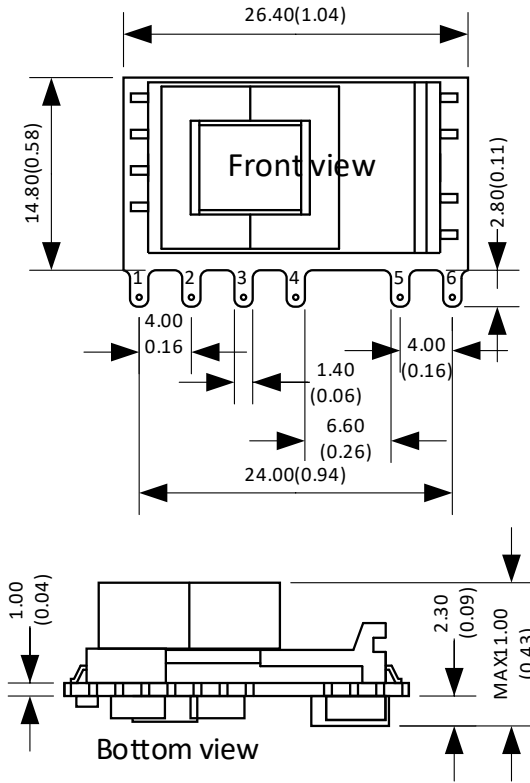

Unless otherwise specified unit: mm(inch)

General tolerance: $\pm 1.00 (\pm 0.04)$

Pin thickness: $\pm 0.10 (\pm 0.004)$

Footprint grid 2.54x2.54 mm

Pin Output Specifications

Pin	Function
1	+V Input (L)
2	-V Input (N)
3	+V_Cap
4	-V_Cap
5	-V Output
6	+V Output

1. It is necessary to add C1 between pin3 to pin4
2. It is necessary to add circuit to the output as shown in recommended circuit
3. The layout of the device is for reference only, please refer to the actual product
4. The slots between pin 4 and pin 5 are required for creepage distance consideration.

Recommended EMC external circuit

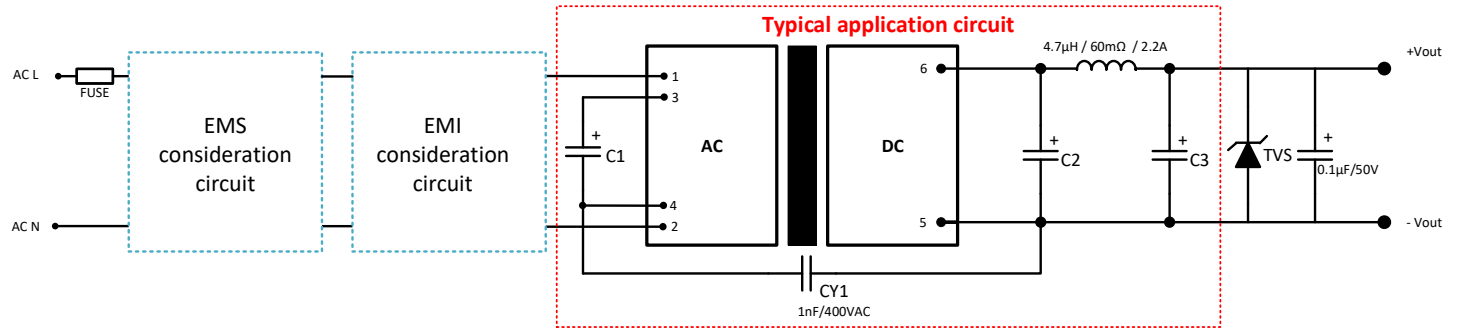

- With the variable combination of below EMS and EMI circuits which offer the different level of protection.
- The components are the must for typical application circuit in red framed area.
- A suppressor diode (TVS) is recommended to protect the application in case of a converter failure and specification should be 1.2 times of the output voltage.

EMI & EMS Recommended Circuit

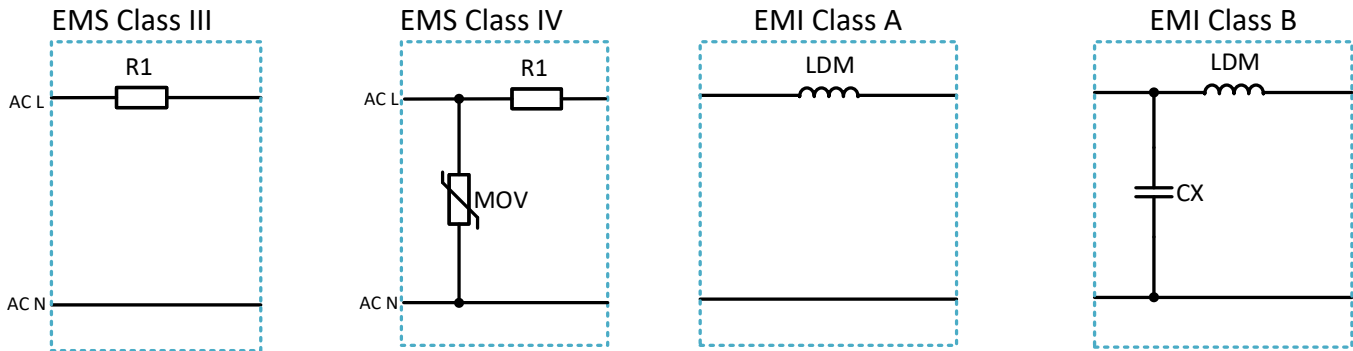

Component	EMS		EMI	
	Class III	Class IV	CLASS A	CLASS B
MOV	-	S14K350	-	-
R1	12Ω/3W, wire-wound	12Ω/2W, wire-wound	-	-
CX	-	-	-	0.1µF/310VAC
LDM	-	-	4.7mH / <15Ω / >0.2A	1.2mH / <4Ω / >0.2A
FUSE	1A/300V slow blow	2A/300V slow blow	-	-

Model name	C1	C2	C3	TVS
AMEOFL5-3S277HALPZ	10µF/450V	820µF/6.3V solid-state capacitor	100µF/35V	7V
AMEOFL5-5S277HALPZ	(-25°C ~ +85°C, 85 – 305VAC input; -40°C ~ +85°C, 165 – 305VAC input)	470µF/16V solid-state capacitor	100µF/35V	7V
AMEOFL5-9S277HALPZ		270µF/16V solid-state capacitor	47µF/35V	12V
AMEOFL5-12S277HALPZ	22µF/450V (-40°C ~ +85°C, 85 – 305VAC input)	270µF/16V solid-state capacitor	47µF/35V	20V
AMEOFL5-15S277HALPZ		220µF/35V	47µF/35V	20V
AMEOFL5-24S277HALPZ		220µF/35V	47µF/35V	30V

Recommended EMC circuit for EN60335

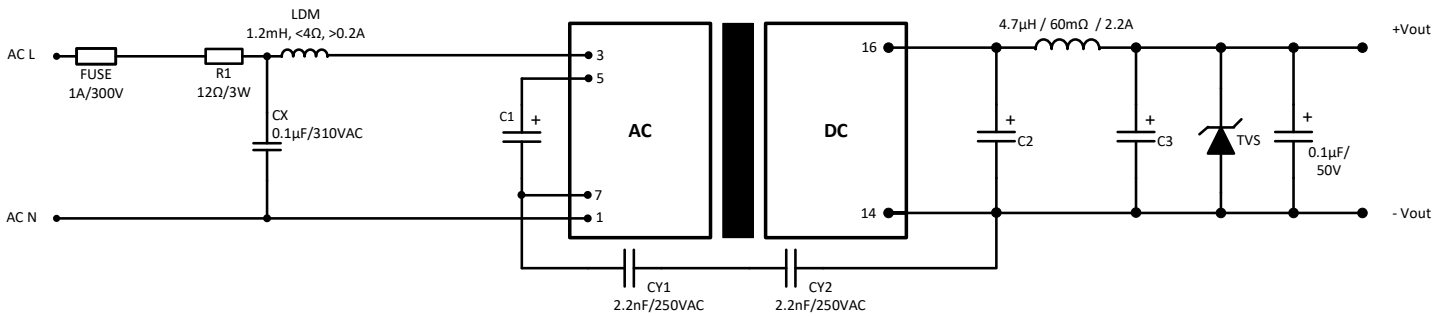

NOTE: **1.** Datasheets are updated as needed and as such, specifications are subject to change without notice. Once printed or downloaded, datasheets are no longer controlled by Aimtec; refer to www.aimtec.com for the most current product specifications. **2.** Product labels shown, including safety agency certifications on labels, may vary based on the date manufactured. **3.** Mechanical drawings and specifications are for reference only. **4.** All specifications are measured at an ambient temperature of 25°C, humidity<75%, nominal input voltage and at rated output load unless otherwise specified. **5.** Aimtec may not have conducted destructive testing or chemical analysis on all internal components and chemicals at the time of publishing this document. CAS numbers and other limited information are considered proprietary and may not be available for release. **6.** This product is not designed for use in critical life support systems, equipment used in hazardous environments, nuclear control systems or other such applications which necessitate specific safety and regulatory standards other the ones listed in this datasheet. **7.** Warranty is in accordance with Aimtec's standard Terms of Sale available at www.aimtec.com.