

Click to  
**ORDER**  
samples

## AMEOFL10-480LPZ

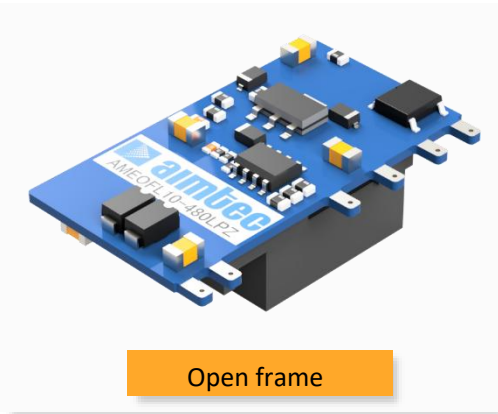

Open frame

The AMEOFL10-480LPZ series is one of Aimtec's highly efficient 10W AC-DC converter series. They feature an ultra-wide input range accepting either AC or DC voltage, high efficiency, compact size, an open-frame package, low power consumption and CLASS II reinforced insulation. A variety of EMC external circuits meet the needs of multiple industries.

This new series offers great operating temperatures, from -40°C to 85°C also features an isolation of 4000VAC for improved reliability and system safety. Furthermore, a high MTBF of 350,000h, output short circuit protection (OSCP) and an output over-current protection (OCP) come standard with the series.

All models are particularly suitable for industrial control, 3-phase applications and instrumentation.

## Features



- Ultra-Wide Input: 85 - 528VAC/100 - 745VDC
- Operating Temp: -40 °C to +85 °C
- High isolation voltage: 4000VAC
- Low ripple & noise, 250mV(p-p), max.
- Output short circuit, over-current protection
- Open frame package



## Summary

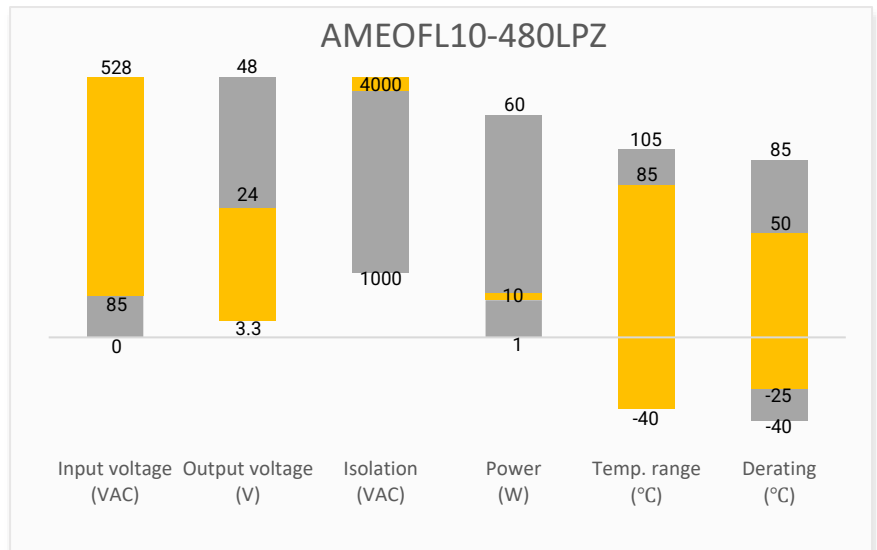

## Training



Product Training Video  
(click to open)

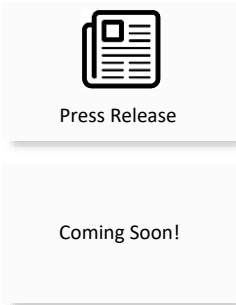

Application Notes

## Applications



Power Grid



Industrial



Telecom



Instrumentation

## Models & Specifications

### Single Output

Model	Input Voltage (VAC/Hz)	Input Voltage (VDC)	Max Output wattage (W)	Output Voltage (V)	Output Current max (A)	Maximum capacitive load ( $\mu$ F)	Efficiency @ 230VAC Typ. (%)
AMEOFL10-3S480LPZ	85-528/47-63	100-745	6.6	3.3	2.0	1500	68
AMEOFL10-5S480LPZ	85-528/47-63	100-745	10	5	2.0	1500	76
AMEOFL10-9S480LPZ	85-528/47-63	100-745	10	9	1.1	1000	79
AMEOFL10-12S480LPZ	85-528/47-63	100-745	10	12	0.83	680	80
AMEOFL10-15S480LPZ	85-528/47-63	100-745	10	15	0.67	470	80
AMEOFL10-24S480LPZ	85-528/47-63	100-745	10	24	0.42	330	81

### Input Specifications

Parameters	Conditions	Typical	Maximum	Units
Input Current	85VAC		250	mA
	115VAC		220	mA
	230VAC		140	mA
	380VAC		120	mA
Inrush current	85VAC	11.6		A
	115VAC	16.5		A
	230VAC	28.6		A
	380VAC	42.6		A
External fuse	Slow blow type, required	2		A
Leakage current	480VAC/50Hz		0.5	mA <sub>(RMS)</sub>

### Output Specifications

Parameters	Conditions	Typical	Maximum	Units
Voltage accuracy	10-100% load, 3.3V output	$\pm 6$		%
	10-100% load, others	$\pm 5$		%
Line regulation	Full load, 3.3V output	$\pm 2$		%
	Full load, Others	$\pm 1.5$		%
Load regulation	10-100% load	$\pm 3$		%
Ripple & Noise	20MHz bandwidth	100	250	mV p-p

### Isolation Specifications

Parameters	Conditions	Typical	Rated	Units
Tested I/O voltage	60 sec, 5mA max		4000	VAC
Insulation resistance	500VDC	>50		M $\Omega$

### General Specifications

Parameters	Conditions	Typical	Maximum	Units
Switching frequency		50		Khz
Safety class	Class II, no FG			
Over Current protection	Auto recovery	$\geq 110$		% of Iout

Short circuit protection	Hiccup, Continuous, Auto recovery			
Power consumption	115VAC	0.2	0.3	W
	Others	0.1	0.15	W
Power derating	+50 °C to +85 °C	1.72		% / °C
	-40 °C to -25 °C	1.33		% / °C
	85VAC ~ 100VAC	1.33		% /VAC
	480VAC ~ 528VAC	0.42		% /VAC
Operating temperature	See derating graph	-40 to +85		°C
Storage temperature		-40 to +105		°C
Temperature coefficient		±0.2		% / °C
Cooling	Free air convection			
Storage Humidity			95	% RH
Weight		11		g
Dimensions (L x W x H)	1.50 x 0.79 x 0.60 inches ( 38.00 x 20.00 x 15.2mm )			
MTBF	> 350 000 hrs (MIL-HDBK -217F, t=+25°C)/Full Load			
NOTE: All specifications in this datasheet are measured at an ambient temperature of 25°C, humidity<75%, nominal input voltage and at rated output load unless otherwise specified.				

## Safety Specifications

### Parameters

Standards	Designed to meet IEC/EN/UL62368, EN660335, IEC/EN62368-1, EN61558, UKCA	
	EMI - Conducted and radiated emission	CISPR32 / EN55032, Class B (With EMI class B external circuit)
	Electrostatic Discharge Immunity	IEC61000-4-2 Contact ±6KV, Air ±8KV, Criteria B
	RF, Electromagnetic Field Immunity	IEC61000-4-3 10V/m, Criteria A
	Electrical Fast Transient/Burst Immunity	IEC61000-4-4 ±2KV, Criteria B (With the recommended circuit for basic application, outdoor general or strong lightning surge environment) IEC61000-4-4 ±4KV, Criteria B (With the recommended circuit for indoor general, indoor industrial or outdoor industrial environment)
	Surge Immunity	IEC61000-4-5 L-L ±1KV, Criteria B (With surge immunity Class III recommended circuit) IEC61000-4-5 L-L ±2KV, Criteria B (With surge immunity Class IV recommended circuit) IEC61000-4-5 L-L ±2KV, L-G ±4KV, Criteria B (With outdoor industrial environment recommended circuit) IEC61000-4-5 L-L ±4KV, Criteria B (With strong lightning surge environment recommended circuit)
	RF, Conducted Disturbance Immunity	IEC61000-4-6 10Vr.m.s, Criteria A
	Voltage dips, Short Interruptions Immunity	IEC61000-4-11 0%, 70%, Criteria B

**Derating**



**Temperature Derating**

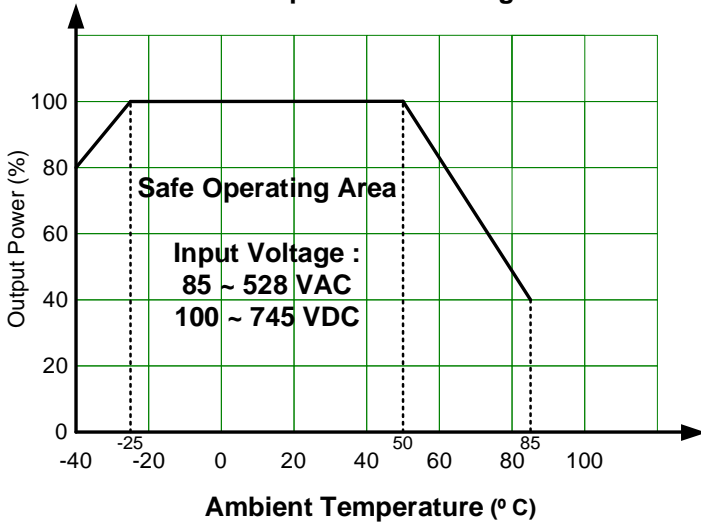

**Input Voltage Derating**

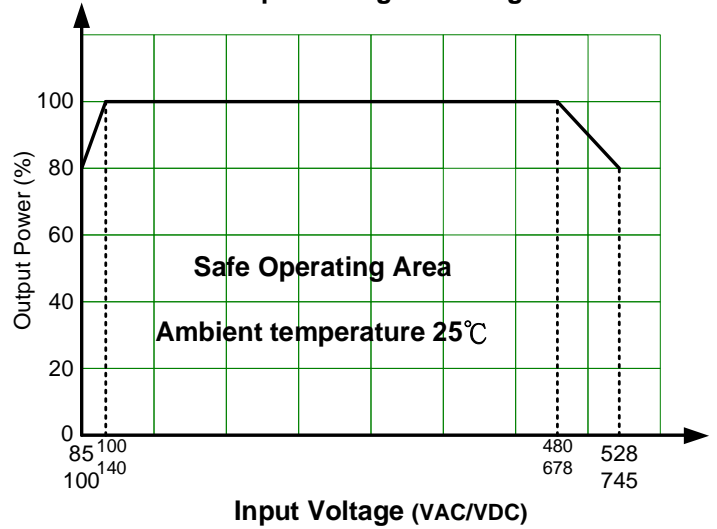

**Dimensions**

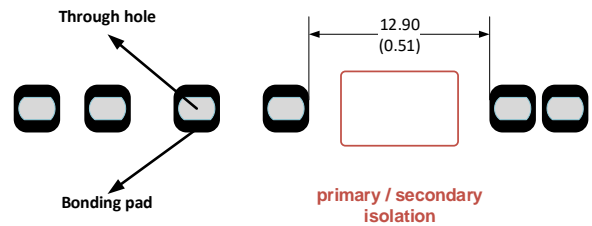
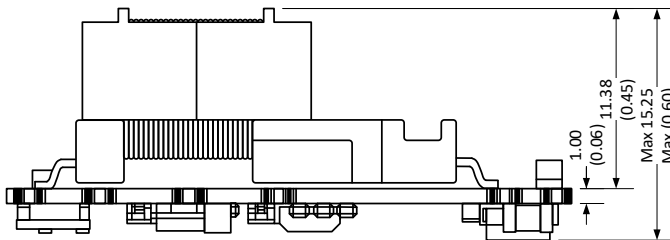
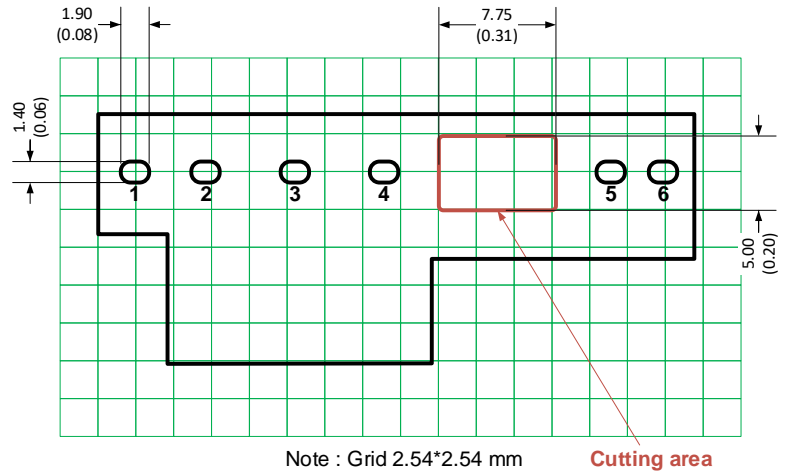
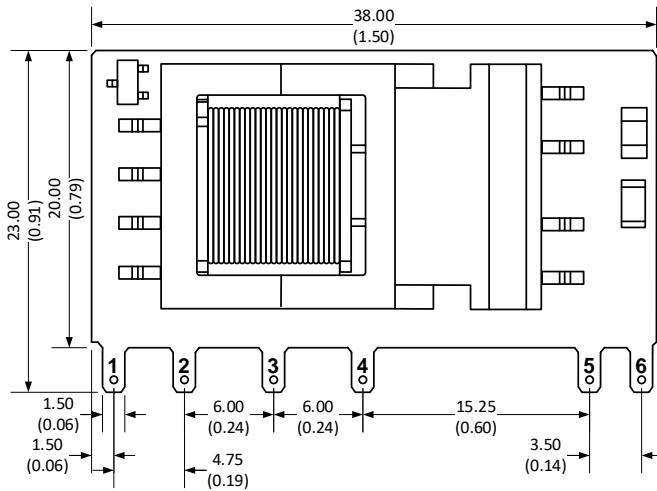

Note:  
Unit: mm [inch]  
General tolerances:  $\pm 1.00 [\pm 0.040]$

Pin Output Specifications	
Pin	Function
1	Input AC L
2	Input AC N
3	+V_Cap
4	-V_Cap
5	-V Output
6	+V Output

1. It is necessary to add C1 between pin3 to pin4
2. It is necessary to add circuit to the output as shown in recommended circuit
3. The layout of the device is for reference only, please refer to the actual product

## Recommended EMC external circuit

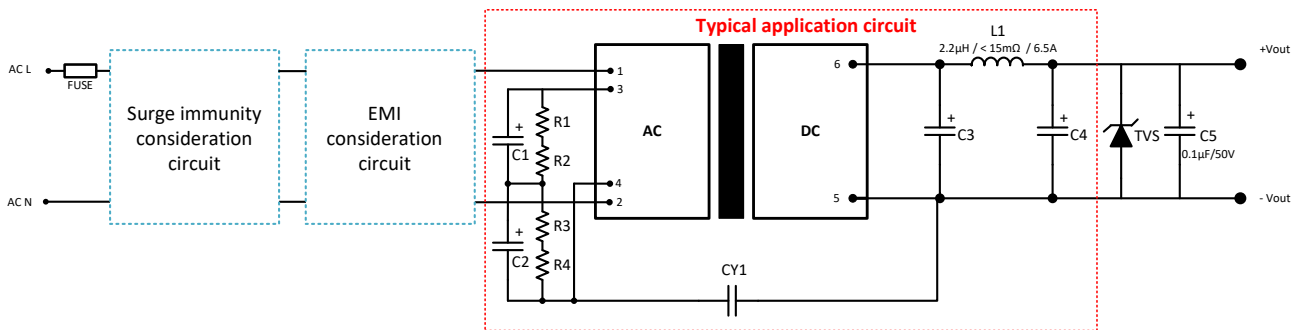

Model name	C1/C2	R1/R2/R3/R4	C3	C4	TVS
AMEOFL10-3S480LPZ	47µF/400V	1MΩ/1206/0.25W	1500µF/6.3V solid-state capacitor	680µF/25V	7V
AMEOFL10-5S480LPZ			820µF/16V solid-state capacitor	330µF/25V	7V
AMEOFL10-9S480LPZ			470µF/16V solid-state capacitor	1000µF/16V	12V
AMEOFL10-12S480LPZ			470µF/16V solid-state capacitor	330µF/25V	20V
AMEOFL10-15S480LPZ			470µF/25V solid-state capacitor	100µF/35V	20V
AMEOFL10-24S480LPZ			470µF/35V	100µF/35V	30V

- With the variable combination of below Surge and EMI circuits which offer the different level of protection.
- The components in the red frame area are mandatory for the typical application circuit.
- A suppressor diode (TVS) is recommended to protect the application in case of a converter failure and specification should be 1.2 times of the output voltage.
- C1/C2 capacitor recommendation: ripple current > 200mA@100KHz, ESR ≤ 100Ω at low temperature

### EMI & Surge Recommended Circuit

Surge immunity Class III

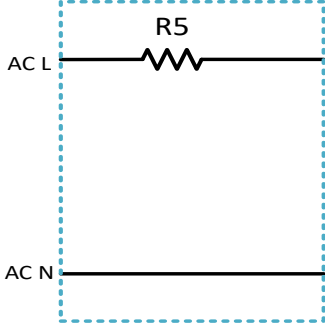

Surge immunity Class IV

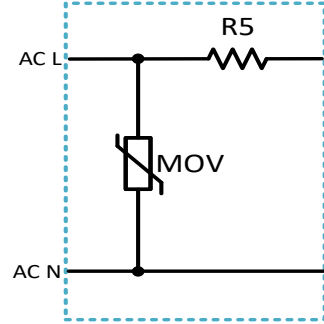

EMI Class A

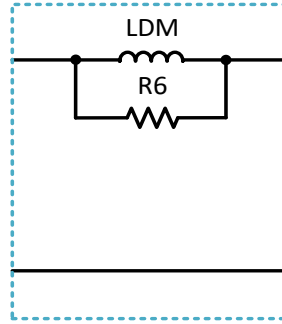

EMI Class B

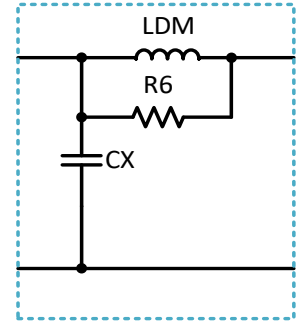

Application environment	Environment Condition		Recommended Circuit & Component Selection			
	Ambient temperature	EFT	Surge immunity	EMI CLASS	CY1	CY2
Basic application	-40 °C ~ +85 °C	±2KV	CLASS III	CLASS A	1nF/400VAC	Wire
Indoor general	-25 °C ~ +55 °C	±4KV	CLASS III	CLASS B	2.2nF/250VAC	2.2nF/250VAC
Indoor industrial	-25 °C ~ +55 °C	±4KV	CLASS IV	CLASS B	1nF/400VAC	Wire
Outdoor general	-40 °C ~ +85 °C	±2KV	CLASS IV	CLASS A	1nF/400VAC	Wire

Component	Surge immunity		EMI	
	Class III	Class IV	CLASS A	CLASS B
MOV	-	S14K550	-	-
R5 (Wire-wound resistor)	6.8Ω/3W		-	-
R6 (Chip resistor)	3.3V / 5V / 12V output	-	10KΩ/1206/0.25W	
	9V / 15V / 24V output	-	4.7KΩ/1206/0.25W	
CX	-	-	-	0.1μF/480VAC
LDM	-	-	2.2mH / < 4.81Ω / > 0.31A	
FUSE	2A/500V slow blow		-	-

### Outdoor industrial environment Recommended Circuit

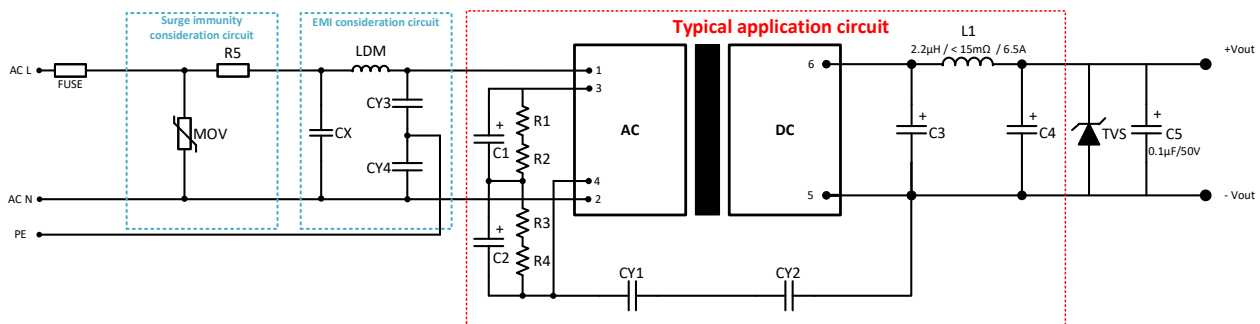

Application environment	Environment Condition		Recommended Circuit & Component Selection			
	Ambient temperature	EFT	Surge immunity	EMI CLASS	CY1/CY3/CY4	CY2
Outdoor industrial	-40 °C ~ +85 °C	±4KV	CLASS IV	CLASS A	1nF/400VAC	Wire

Component	Surge immunity	EMI
	Class IV	CLASS A
MOV	<b>S14K550</b>	-
R5(Wire-wound resistor)	<b>6.8Ω/3W</b>	-
CX	-	<b>0.1μF/480VAC</b>
LDM	-	<b>2.2mH / &lt; 4.81Ω / &gt; 0.31A</b>
FUSE	<b>2A/500V slow blow</b>	-

**Strong lightning surge environment Recommended Circuit**

**Full-wave rectification**

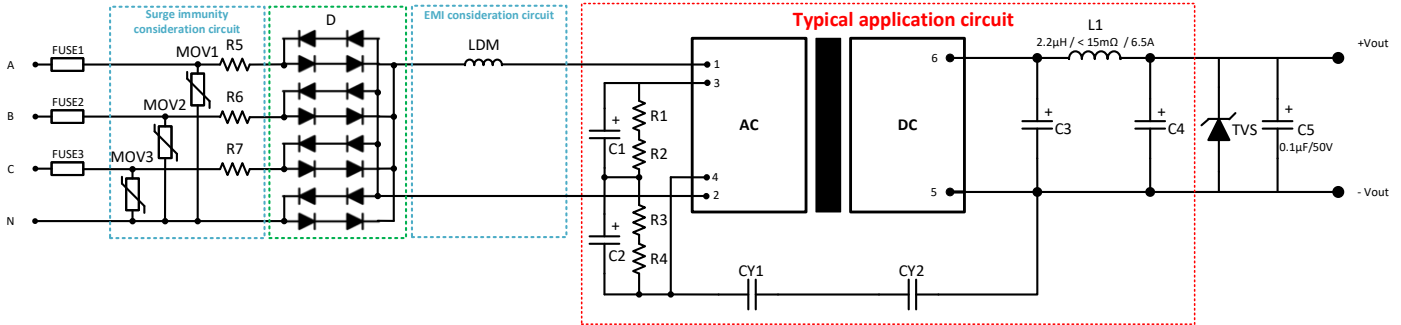

**Half-wave rectification**

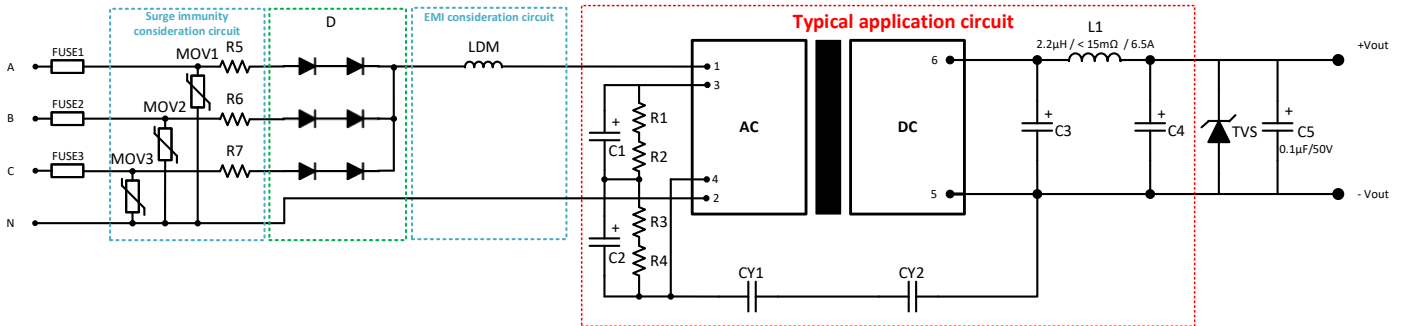

Application environment	Environment Condition		Recommended Circuit & Component Selection			
	Ambient temperature	EFT	Surge immunity	EMI CLASS	CY1/CY3/CY4	CY2
Strong lightning surge	-40°C ~ +85°C	±2KV	CLASS IV	CLASS A	1nF/400VAC	Wire

Component	Surge immunity	EMI
	Class IV	CLASS A
MOV1 / MOV2 / MOV3	<b>S14K550</b>	-
R5 / R6 / R7(Wire-wound resistor)	<b>12Ω/5W</b>	-
D	<b>2A/1000V</b>	
LDM	-	<b>2.2mH / &lt; 4.81Ω / &gt; 0.31A</b>
FUSE1 / FUSE2 / FUSE3	<b>6.3A/500V slow blow</b>	-

**NOTE:** 1. Datasheets are updated as needed and as such, specifications are subject to change without notice. Once printed or downloaded, datasheets are no longer controlled by Aimtec; refer to [www.aimtec.com](http://www.aimtec.com) for the most current product specifications. 2. Product labels shown, including safety agency certifications on labels, may vary based on the date manufactured. 3. Mechanical drawings and specifications are for reference only. 4. All specifications are measured at an ambient temperature of 25°C, humidity<75%, nominal input voltage and at rated output load unless otherwise specified. 5. Aimtec may not have conducted destructive testing or chemical analysis on all internal components and chemicals at the time of publishing this document. CAS numbers and other limited information are considered proprietary and may not be available for release. 6. This product is not designed for use in critical life support systems, equipment used in hazardous environments, nuclear control systems or other such applications which necessitate specific safety and regulatory standards other the ones listed in this datasheet. 7. Warranty is in accordance with Aimtec's standard Terms of Sale available at [www.aimtec.com](http://www.aimtec.com).