



SPECIFICATIONS FOR LCD MODULE

CUSTOMER	
CUSTOMER PART NO.	
AMPIRE PART NO.	AM-480272H3HZQW-TW0H-D
APPROVED BY	
DATE	

- Preliminary Specification
 Approved Specification

AMPIRE CO., LTD.

**4F., No.116, Sec. 1, Xintai 5th Rd., Xizhi Dist., New Taipei
City221, Taiwan (R.O.C.)**

新北市汐止區新台五路一段 116 號 4 樓(東方科學園區 A 棟)

TEL:886-2-26967269 , FAX:886-2-26967196 or 26967270

APPROVED BY	CHECKED BY	ORGANIZED BY
Kokai	Mark	Lawlite

*This specification is subject to change without notice.

RECORD OF REVISION

Revision Date	Page	Contents	Editor
2024/12/04	--	New Release	Lawlite

1 Features

4.3 inch Amorphous-TFT-LCD (Thin Film Transistor Liquid Crystal Display) module. This module is composed of a 4.3" TFT-LCD panel, LCD controller, power driver circuit, touch panel and backlight unit.

1.1 TFT Panel Feature :

- (1) Construction: 4.3" a-Si color TFT-LCD, White LED Backlight and PCB.
- (2) Resolution (pixel): 480(R.G.B) X 272
- (3) Number of the Colors : 262K colors (R , G , B 6 bit digital each)
- (4) LCD type : Transmissive Color TFT LCD (normally White)
- (5) Interface: 40 pin pitch 0.5
- (6) Power Supply Voltage: 3.3V single power input. Built-in power supply circuit.
- (7) Viewing Direction: 6 O'clock (The direction it's hard to be discolored):

1.2 LCD Controller Feature:

- (1) MCU interface 8/9/16/18 bit 80&68 series MCU interface.
- (2) Display RAM size : 640x320x3x6 bits. Ex : 320x240 two frame buffer with 262K colors.
- (3) Arbitrary display memory start position selection.
- (4) MCU interface : 8 bit / 9 bit / 16bit / 18 bits 80/68 MPU interface.
- (5) 8 bit / 16 bit interface support 65K (R5G6B5) /262K(R6G6B6) colors data format.
- (6) 9 bit / 18 bit interface support 262K(R6G6B6) colors data format only.

2 Physical specifications

Item	Specifications	Unit
Display resolution(dot)	480(R.G.B.) (W) x 272(H)	mm
Active area	95.04 (W) x 53.856 (H)	mm
Screen size	4.3 (Diagonal)	mm
Pixel size	0.198 (W) x 0.198 (H)	um
Color configuration	R.G.B stripe	
Weight	T.B.D	mg
Backlight unit	LED	

3 Default Setting & Option

- Interface :

The user can select the MCU interface by change the Jumper & Resister Array.

Setting Interface Type	JP1	RA1	RA2	RA3	RA4	Remark
80-18Bit interface	1,2 short 2,3 open	2K ohm	OPEN	OPEN	OPEN	
80-16Bit interface	1,2 short 2,3 open	OPEN	2K ohm	OPEN	OPEN	Default
80-9Bit interface	1,2 short 2,3 open	OPEN	OPEN	2K ohm	OPEN	
80-8Bit interface	1,2 short 2,3 open	OPEN	OPEN	OPEN	2K ohm	
68-18Bit interface	1,2 open 2,3 short	2K ohm	OPEN	OPEN	OPEN	
68-16Bit interface	1,2 open 2,3 short	OPEN	2K ohm	OPEN	OPEN	
68-9Bit interface	1,2 open 2,3 short	OPEN	OPEN	2K ohm	OPEN	
68-8Bit interface	1,2 open 2,3 short	OPEN	OPEN	OPEN	2K ohm	

- LED Driver:

The user can select the LED driver built-in or not.

Pin Define Interface Type	PIN3 LEDA/PWM	PIN4 LEDK	Remark
Without LED Driver	LED Anode	LED Cathode	
With LED Driver	PWM The PWM pin combined enable and brightness adjust function. When PWM=High constantly, the LED back-light is turn on. When PWM=GND constantly, the LED back-light is turn off. When PWM signal (100Hz to 1KHz) input, the LED Back-light brightness is relative to duty cycle of the PWM signal.	NC This pin must be open	Default

- Touch panel and Touch panel controller:

The user can select the with TP controller or without TP controller.

Pin Define Option	SK/X1	DO/X2	DI/Y1	TPCS/Y2	IRQ	Remark
Without TP	NC	NC	NC	NC	NC	
With TP / Without TP controller	X1	X2	Y1	Y2	NC	Default
With TP / With TP controller	SK	DO	DI	TPCS	IRQ	

If user want to change the default setting for mass production, please contact with Ampire. We'll apply a new P/N for you.

Parameter	Condition	Standard Value
Terminal Resistance	X Axis	450 ~ 1250 Ω
	Y Axis	100 ~ 700 Ω
Insulating Resistance	DC 25 V	More than 20M Ω
Linearity	--	$\pm 1.5\%$
Notes life by Pen	Note A	100,000 times(min)
Input life by finger	Note B	1,000,000 times (min)

Note A

Notes area for pen notes life test is 10 x 9 mm.

Size of word is 7.5 x 6.72

Shape of pen end: R8

Load: 150g

Note B

By Silicon rubber tapping at same point

Shape of rubber end: R0.8

Load: 150g

Frequency: 5 Hz

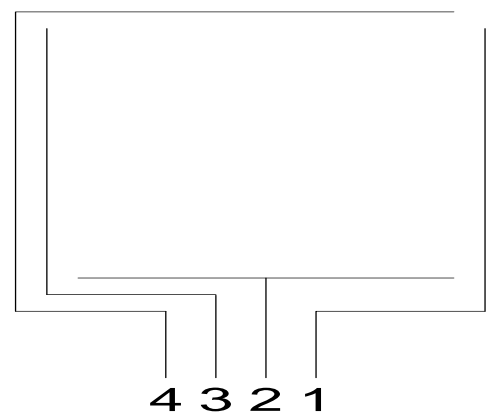

Interface

No.	Symbol	Function
1	XR	Touch Panel Right Signal in X Axis
2	YD	Touch Panel Bottom Signal in Y Axis
3	XL	Touch Panel Left Signal in X Axis
4	YU	Touch Panel Top Signal in Y Axis

4 Electrical specification

4.1 Absolute max. ratings

4.1.1 Electrical Absolute max. ratings

Item	Symbol	Condition	Min.	Max.	Unit	Remark
Power voltage	VDD	VSS=0	-0.3	4	V	
Input voltege	V _{in}		-0.3	VDD+0.3	V	Note 1

Note1: /CS,/WR,/RD,RS,DB0~DB17

4.1.2 Environmental Absolute max. ratings

Item	OPERATING		STORAGE		Remark
	MIN	MAX	MIN	MAX	
Temperature	-20	70	-30	80	Note2,3,4,5,6,7
Humidity	Note1		Note1		
Corrosive Gas	Not Acceptable		Not Acceptable		

Note1 : Ta ≤ 40°C : 85% RH max

Ta > 40°C : Absolute humidity must be lower than the humidity of 85%RH at 40°C

Note2 : For storage condition Ta at -30°C < 48h , at 80°C < 100h

For operating condition Ta at -20°C < 100h

Note3 : Background color changes slightly depending on ambient temperature. This phenomenon is reversible.

Note4 : The response time will be slower at low temperature.

Note5 : Only operation is guarantied at operating temperature. Contrast , response time, another display quality are evaluated at +25°C

Note6 :

- LED BL : When LCM is operated over 40°C ambient temperature, the I_{LED} of the LED back-light should be follow :

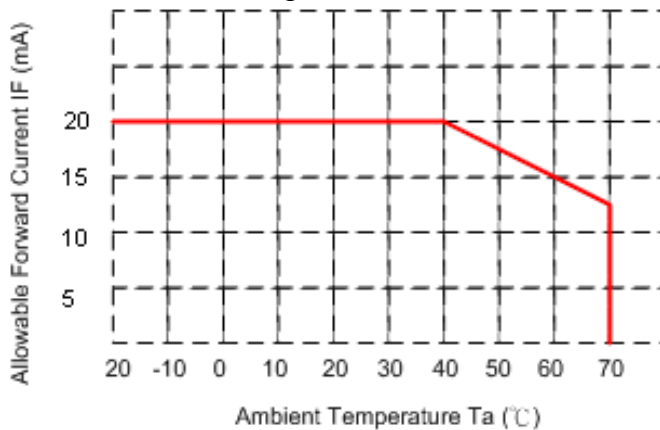

Note7 : This is panel surface temperature, not ambient temperature.

Note8 :

- LED BL:When LCM be operated over than 40°C , the life time of the LED back-light will be reduced.

4.2 Electrical characteristics

4.2.1 DC Electrical characteristic of the LCD

typical operating conditions (GND=0V)

Item	Symbol	Min.	Typ.	Max.	Unit	Remark
Power supply	V_{DD}	3.0	3.3	3.6	V	
	TP_ V_{DD}	3.0	3.3	3.6	V	
Input Voltage for logic	H Level	V_{IH}	$0.7 V_{DD}$	--	V_{DD}	Note 1
	L Level	V_{IL}	0	--	$0.3 V_{DD}$	
Power Supply current	I_{DD}		32	--	mA	Note 2

Note1: : Hsync, Vsync, DE, DCLK, DISP, R0~R7, G0~G7, B0~B7

Note2: TFT power supply current.

$V_{DD}=3.3V$, $f_v=60Hz$, $T_a=25^{\circ}C$, Display pattern: All White

4.2.2 Electrical characteristic of LED Back-light

Item	Symbol	Conditions	MIN.	TYP.	MAX.	Unit
Forward voltage	V_f	$I_f = 18\text{mA}$		23.1	25.2	V
Forward current	I_f	7-chip serial	-	18	20	mA
Uniformity (with L/G)	-	$I_f = 18\text{mA}$	75%*1	-	-	
Life Time (LED Dice)	-	$T_a = 25^\circ\text{C}$, $I_F = 20\text{mA}$	17.7K			Hrs
Luminous color	White					
Chip connection	7 chip serial connection					

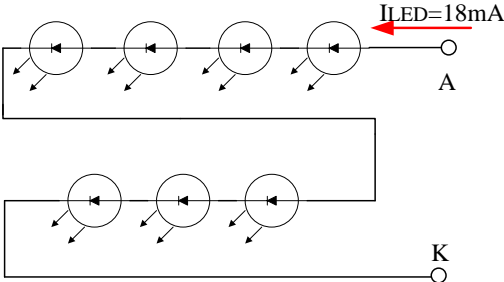

Note (1) LED life time (Hr) can be defined as the time in which it continues to operate under the condition: $T_a=25\pm 3^{\circ}\text{C}$, typical I_L value indicated in the above table until the brightness becomes less than 50%.

Note (2) The “LED life time” is defined as the module brightness decrease to 50% original brightness at $T_a=25^{\circ}\text{C}$ and $I_L=20\text{mA}$. The LED lifetime could be decreased if operating I_L is larger than 20mA. The constant current driving method is suggested.

The constant current source is needed for white LED back-light driving. When LCM is operated over 60°C ambient temperature, the I_L of the LED back-light should be adjusted to 18mA max.

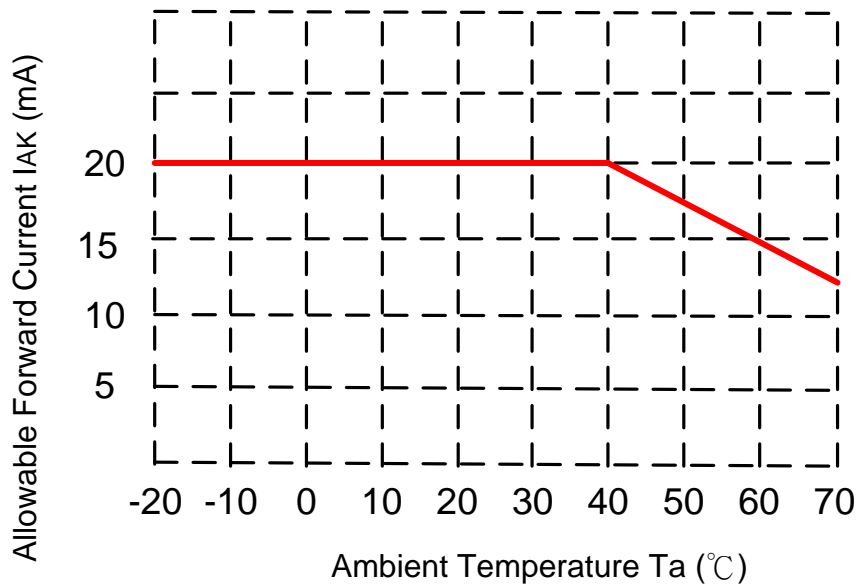

4.3 AC Timing characteristic of the Graphic TFT LCD controller

4.3.1 80 series Timing

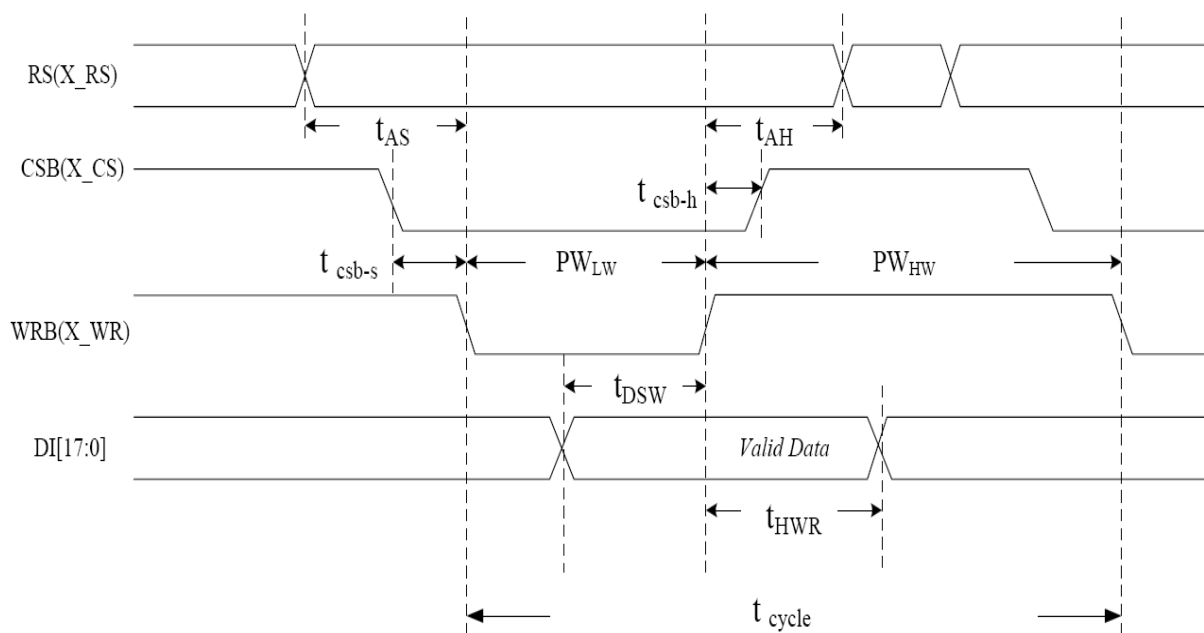

Symbol	Parameter	Min	Typ	Max	Unit	Remark
t_{cycle}	Enable cycle time	100	200		ns	
PW_{HW}	Enable high-level pulse width	66	70		ns	
PW_{LW}	Enable low-level pulse width	33	130		ns	
t_{AS}	RS setup time	16	25		ns	
t_{AH}	RS hold time	16	45		ns	
t_{DSW}	Write data setup time	50	50		ns	
t_{HWR}	Write data hold time	40	50		ns	
t_{csb-s}	CSB setup time	16	20		ns	
t_{csb-h}	CSB hold time	16	30		ns	

5 Optical specification

Item	Symbol	Condition	Min.	Typ.	Max.	Unit	Remark
Response Time	$T_r + T_f$	$\Theta = 0^\circ$		30	40	ms	Note 1,2,3,5
Contrast ratio	CR	At optimized viewing angle	(640)	(800)	-		Note 1,2,4,5
Viewing Angle	Top Bottom Left Right	$CR \geq 10$	75	85	- - - -	deg.	Note1,2, 5,6
Brightness	Y_L	$I_{LED} = 20.0\text{mA}$, 25°C	400	500	-	cd/m ²	Note 7
Red chromaticity	XR	$\Theta = 0^\circ$ $\Theta = 0^\circ$	Typ -0.05	0.629	Typ +0.05		Note 7 For reference only. These data should be update according the prototype.
	YR			0.326			
Green chromaticity	XG			0.337			
	YG			0.546			
Blue chromaticity	XB			0.136			
	YB			0.143			
White chromaticity	XW			0.320			
	YW			0.345			

For reference only. These data should be update according the prototype.

Note 1: Ambient temperature = 25°C , and lamp current $I_{LED} = 20\text{mA}$. To be measured in the dark room.

Note 2: To be measured on the center area of panel with a viewing cone of 1° by Topcon luminance meter BM-7, after 10 minutes operation.

Note 3. Definition of response time:

The output signals of photo detector are measured when the input signals are changed from "black" to "white" (falling time) and from "white" to "black" (rising time), respectively. The response time is defined as the time interval between the 10% and 90% of amplitudes. Refer to figure as below.

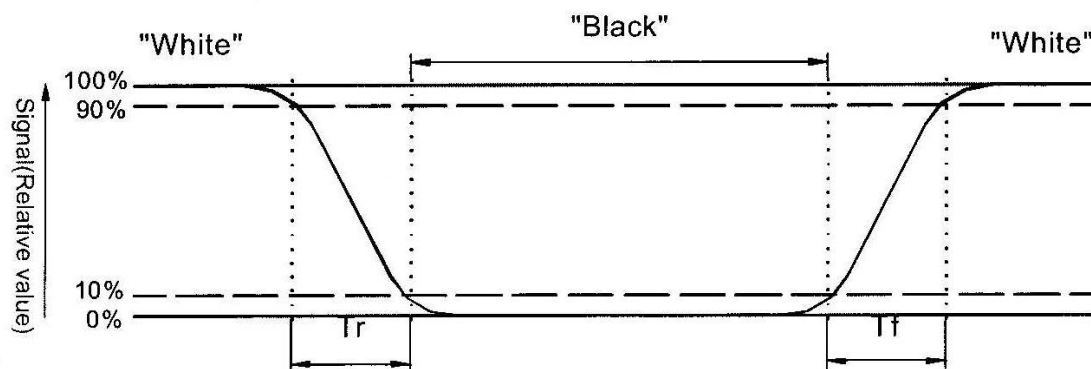

Note 4. Definition of contrast ratio:

Contrast ratio is calculated with the following formula.

$$\text{Contrast ratio(CR)} = \frac{\text{Brightness of White}}{\text{Brightness of Black}}$$

Note 5: White $V_i = V_{i50} + 1.5V$

Black $V_i = V_{i50} + 2.0V$

“±” means that the analog input signal swings in phase with V_{COM} signal.

“ $\frac{-}{+}$ ” means that the analog input signal swings out of phase with V_{COM} signal.

V_{i50} : The analog input voltage when transmission is 50%. The 100% Transmission is defined as the transmission of LCD panel when all the Input terminals of module are electrically opened.

Note 6. Definition of viewing angle. Refer to figure as below.

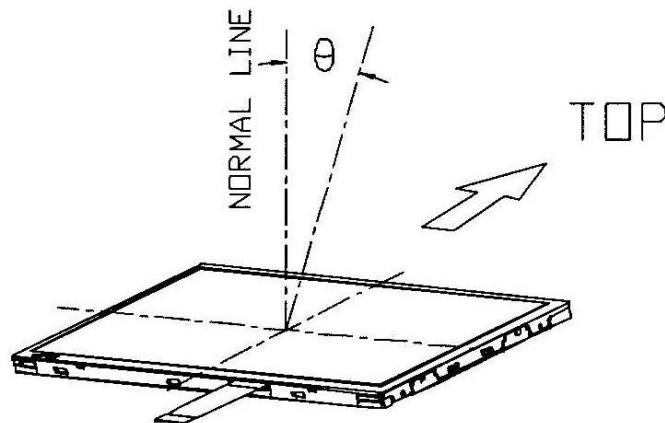

Note 7. Measured at the center area of the panel when all the input terminals of LCD panel are electrically opened.

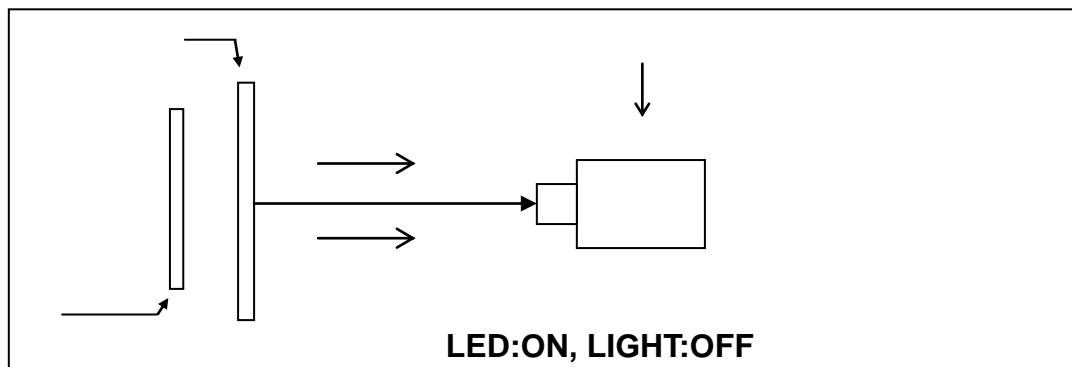
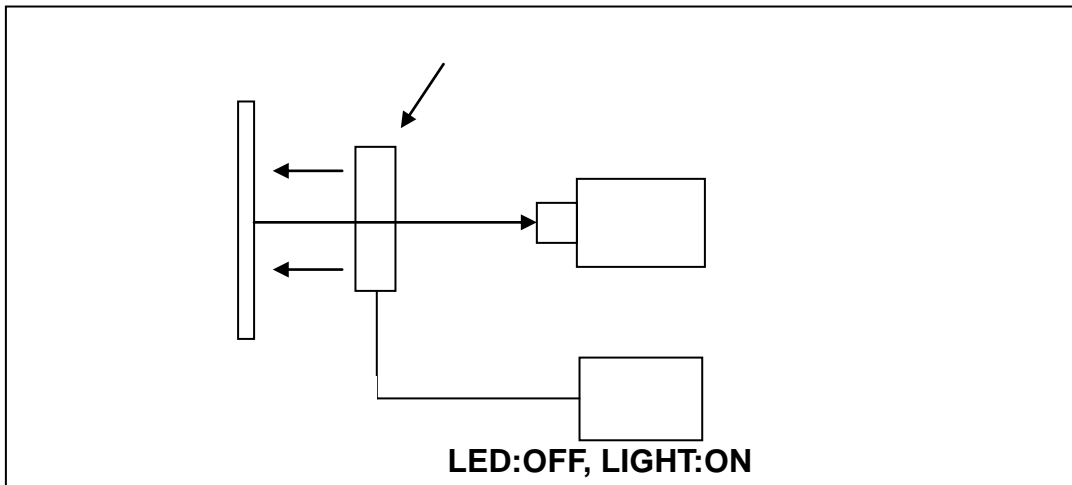

6 Interface specifications

6.1 Driving signals for the TFT panel

Pin no	Symbol	I/O	Description	Remark
1 ~ 2	VSS		GND	
3	LED_A/PWM		Without LED driver	LED Anode
			With LED Driver	PWM
4	LED_K		Without LED driver	LED Cathode
			With LED Driver	Must be OPEN
5	/RESET	I	Reset signal for TFT LCD controller	
6	RS	I	Register and Data select for TFT LCD controller	
7	/CS	I	Chip select low active signal for TFT LCD controller	
8	/WR(E)	I	80mode : /WR low active signal for TFT LCD controller	
			68mode : E signal latch on rising edge	
9	/RD(R/W)	I	80mode : /RD low active signal for TFT LCD controller	
			68mode : R/W signal Hi: read Lo:Write	
10 ~ 27	DB0 ~ DB17	I/O	Data Bus	
28	65K/262K	I	Select colors data format H : 262K L : 65K	
29	VSS		GND	
30	XR	I	Touch panel X axis (RIGHT)	
31	XL	I	Touch panel X axis (Left)	
32	YD	I	Touch panel Y axis (TOP)	
33	YU	I	Touch panel Y axis (BOTTOM)	
34	NC		No connection	
35 ~ 37	VDD		Power supply for the logic (3.3V)	
38 ~ 40	VSS		GND	

7 BLOCK DIAGRAM

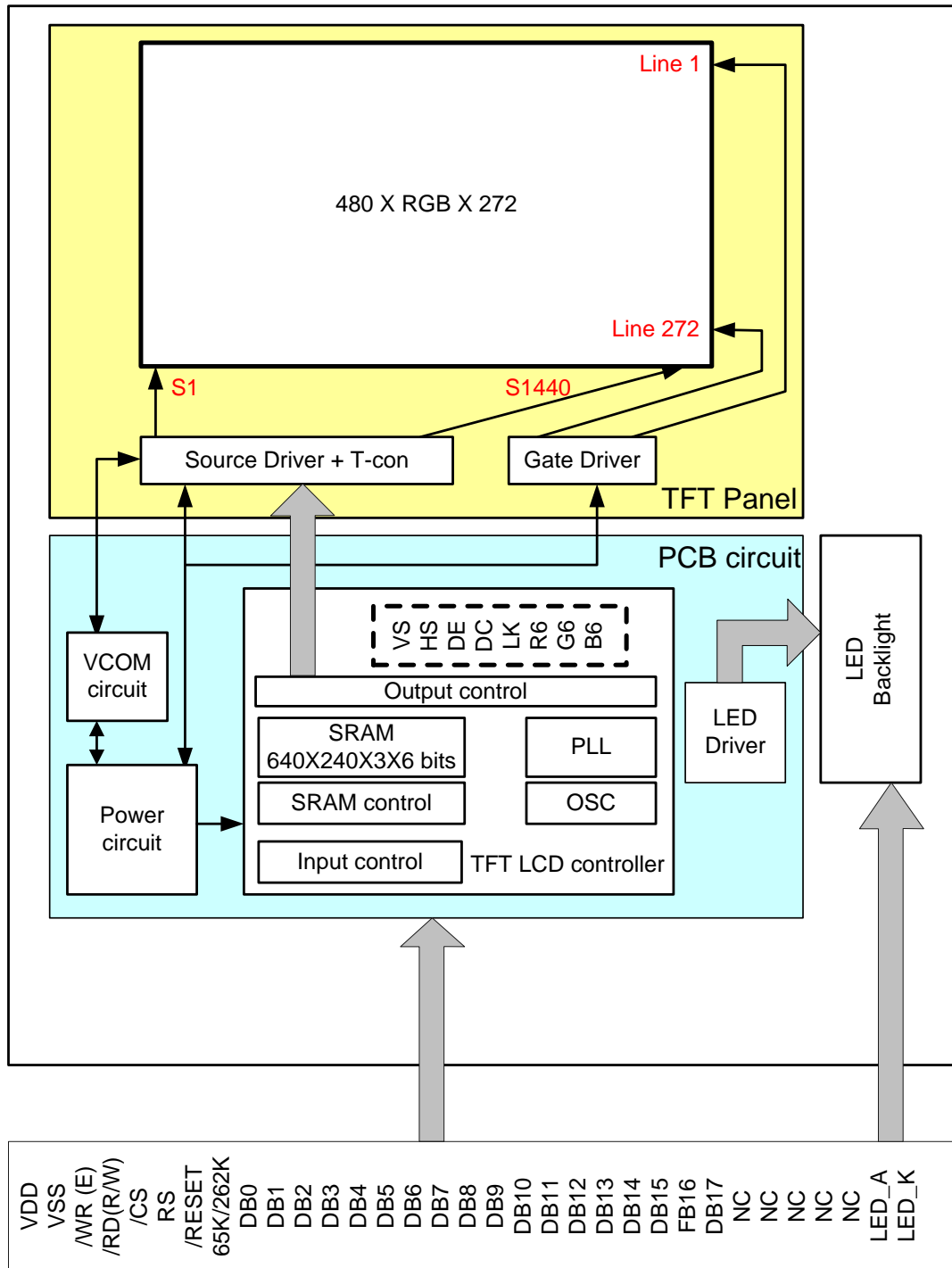

8 Interface Protocol

8.1 18Bit-80/68-Write to Command Register

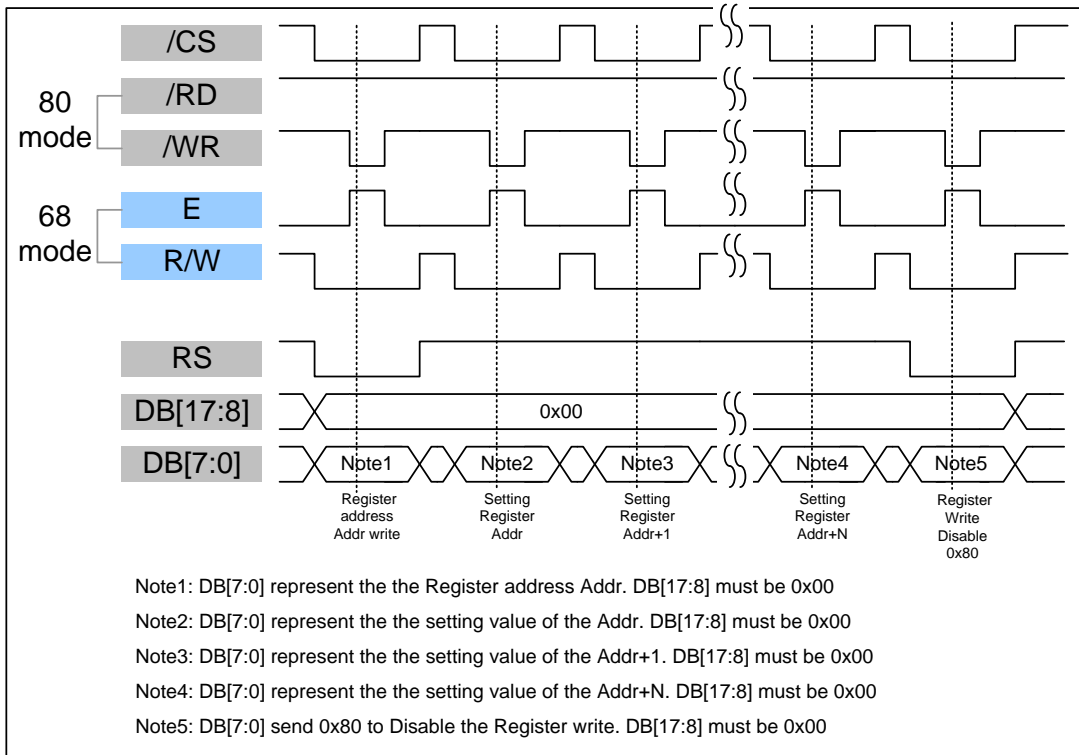

8.2 18Bit-80/68-Write to Display RAM

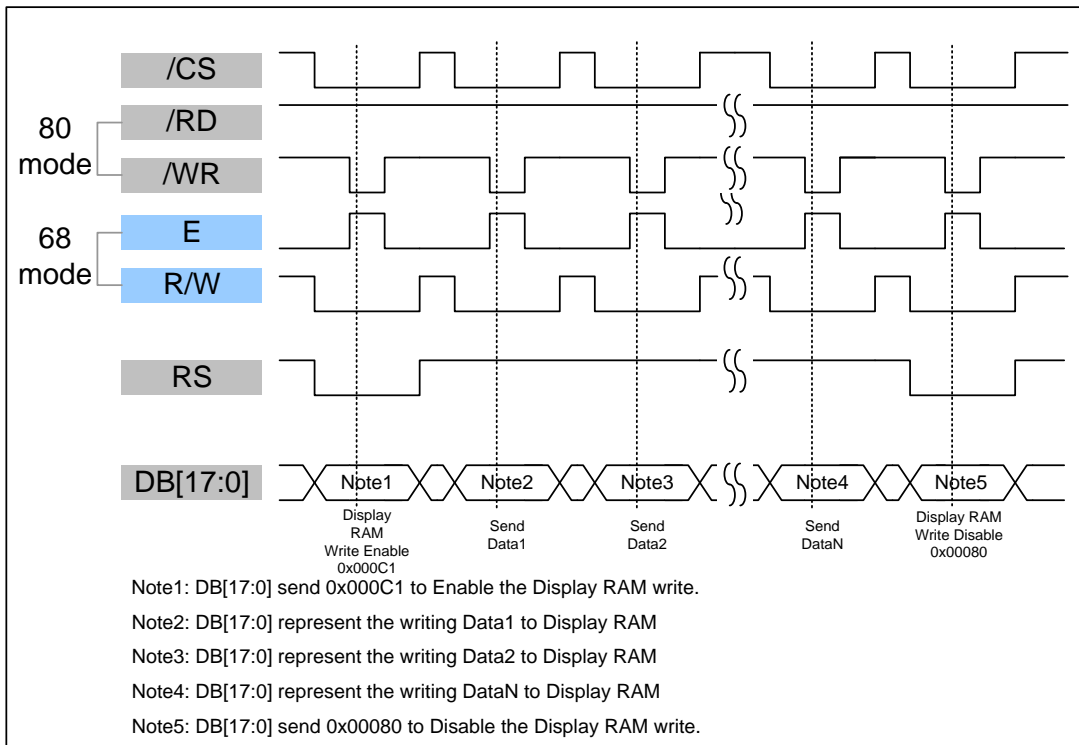

8.3 16Bit-80/68- Write to Command Register

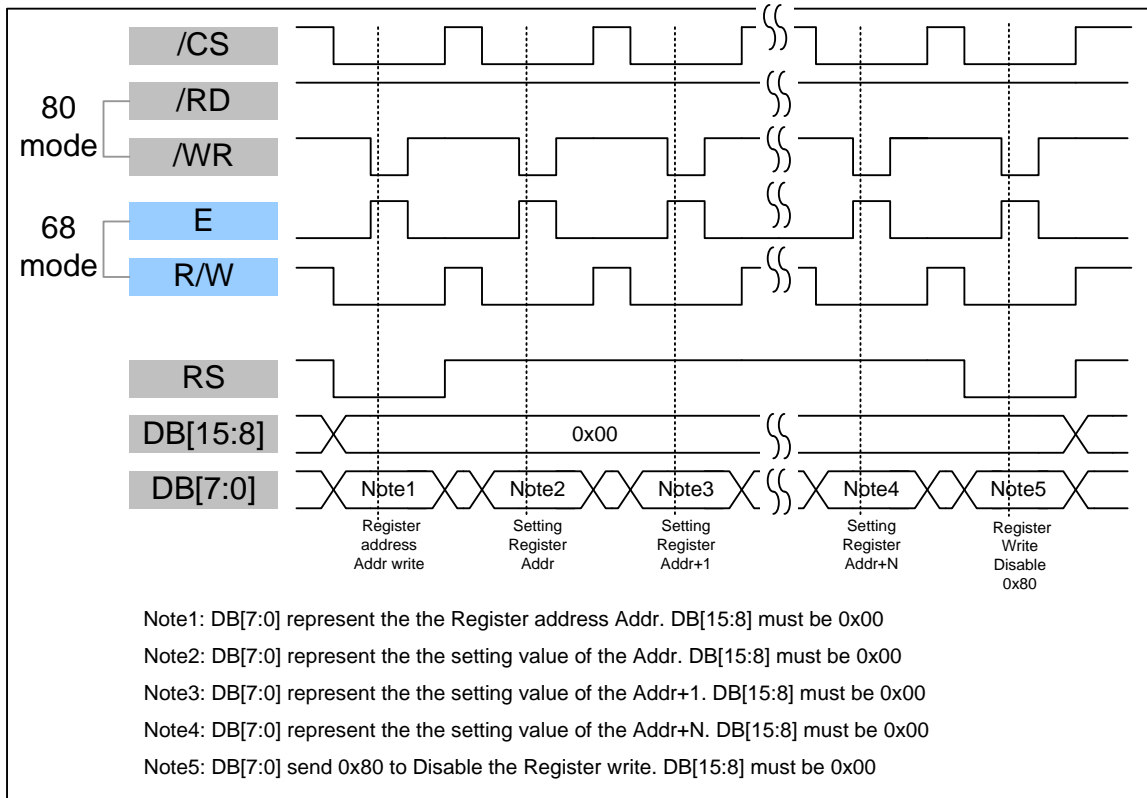

8.4 16Bit-80/68-Write to Display RAM

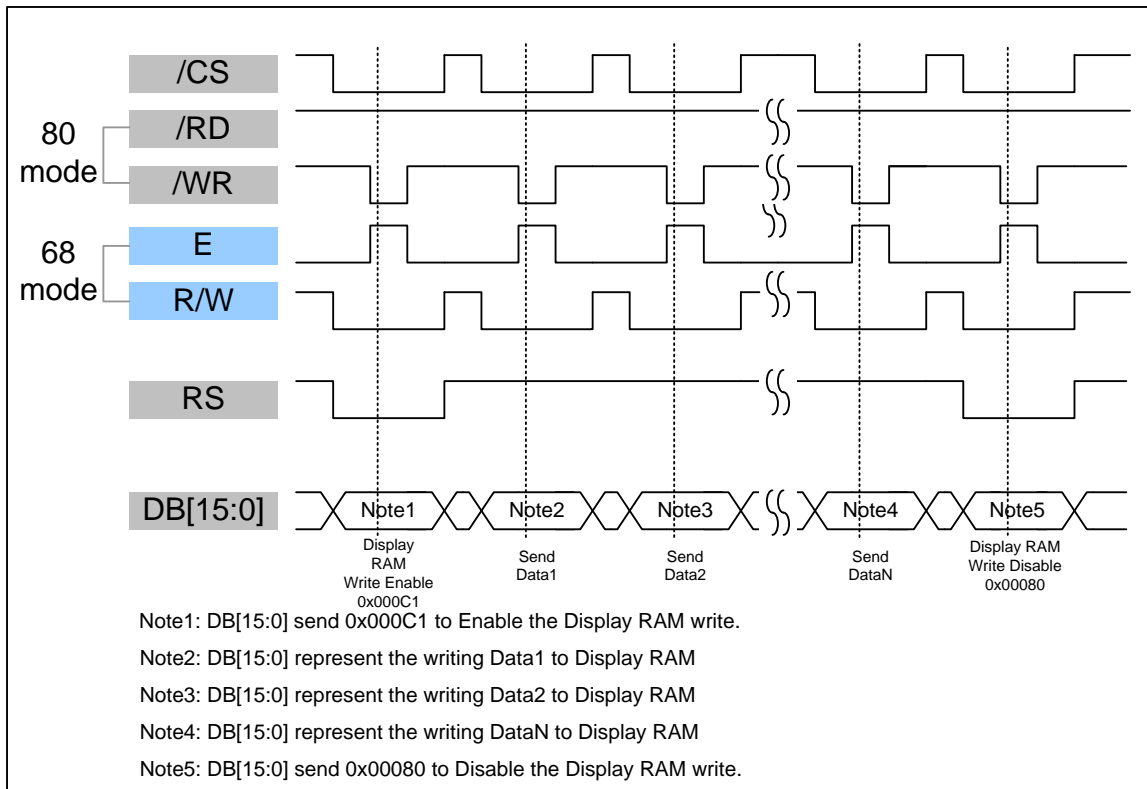

8.5 9Bit-80/68- Write to Command Register

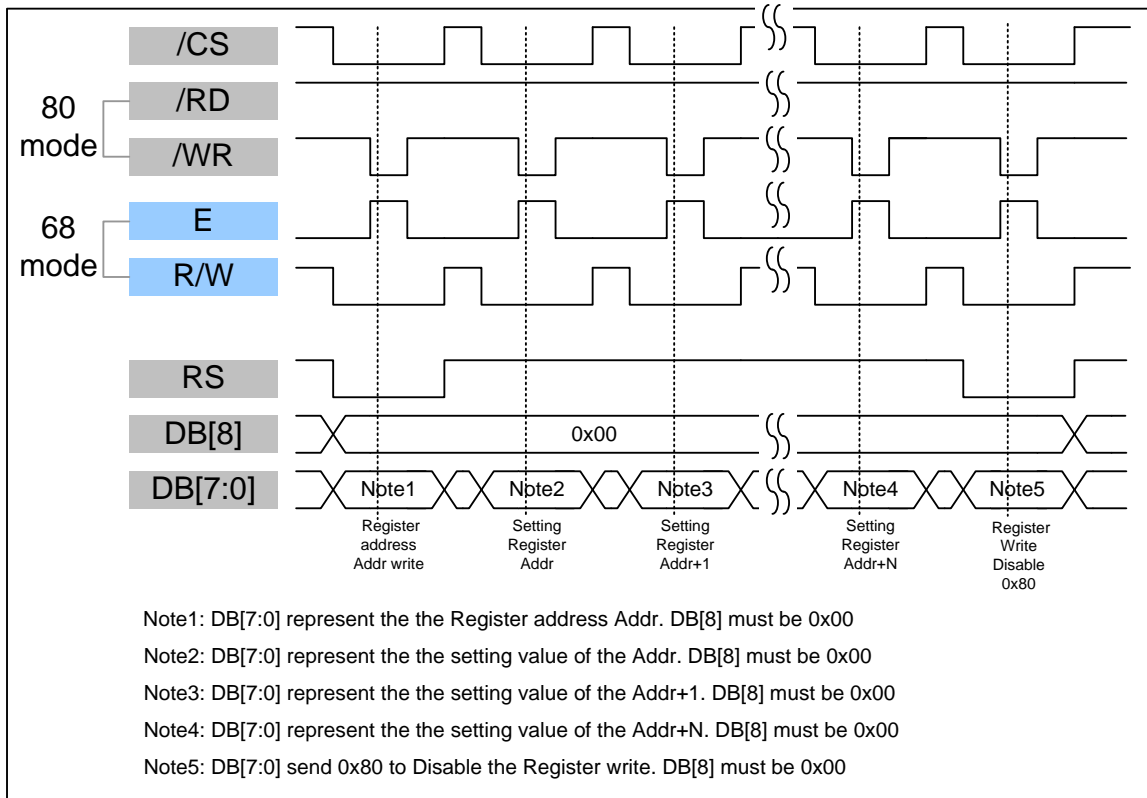

8.6 9Bit-80/68-Write to Display RAM

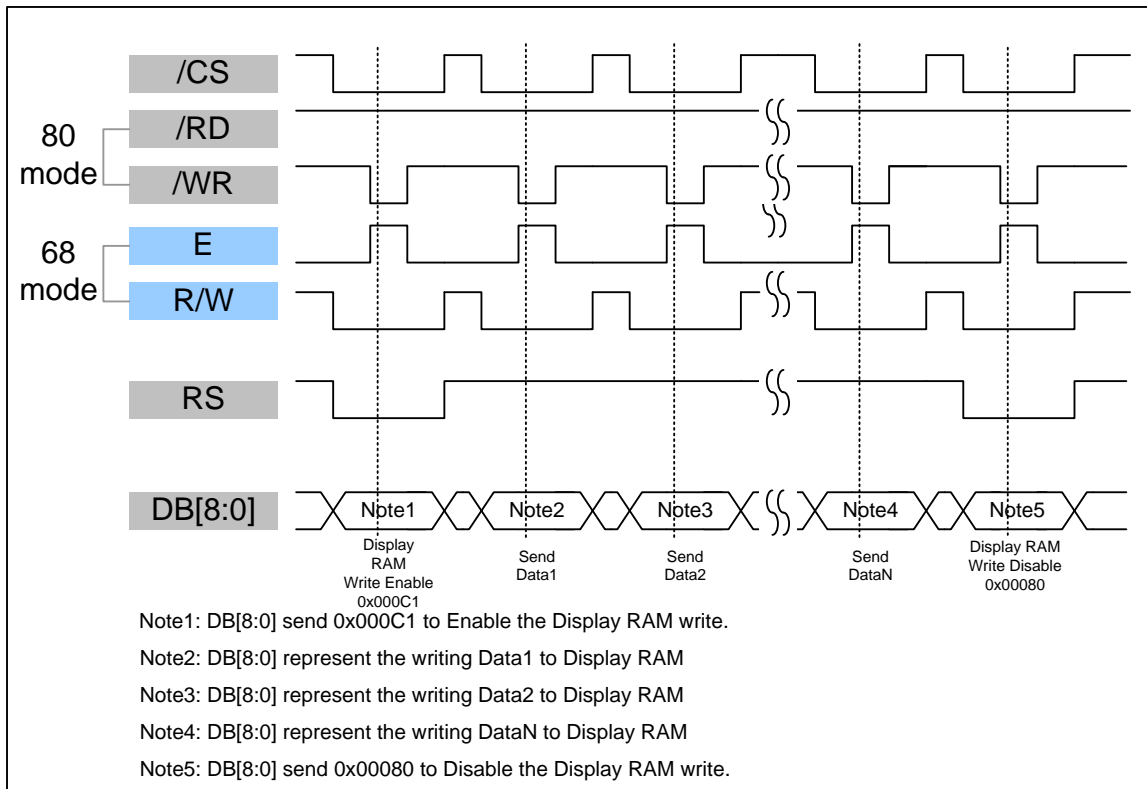

8.7 8Bit-80/68- Write to Command Register

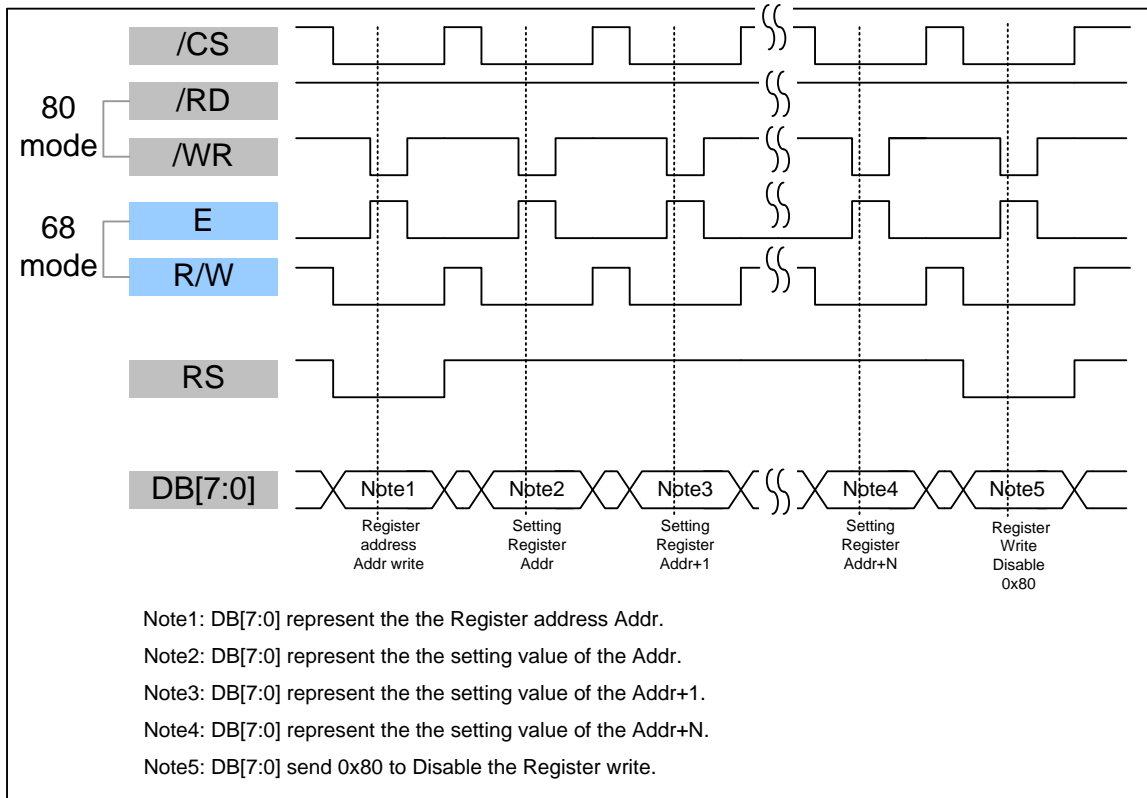

8.8 8Bit-80/68-Write to Display RAM

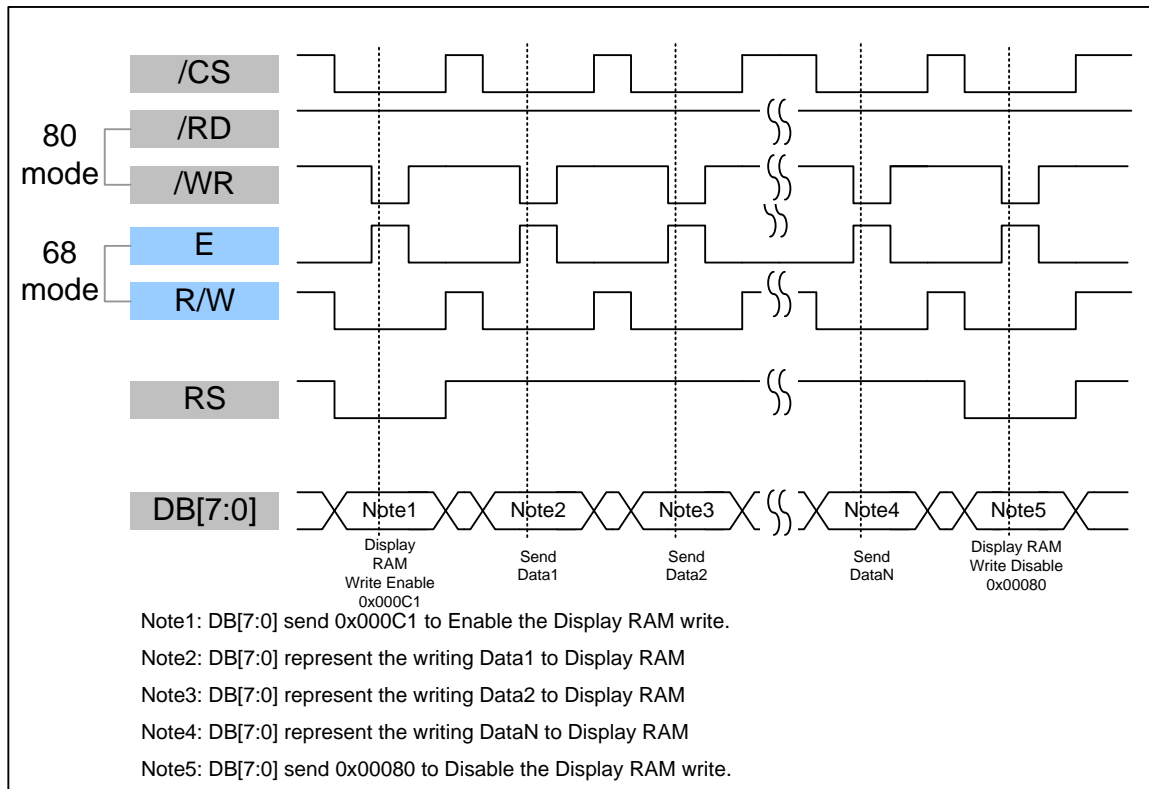

8.9 Data transfer order Setting

8.9.1 18 bit interface 262K color only (Pin28 65K/262K =High)

DB	17	16	15	14	13	12	11	10	9	8	7	6	5	4	3	2	1	0
	R5	R4	R3	R2	R1	R0	G5	G4	G3	G2	G1	G0	B5	B4	B3	B2	B1	B0

8.9.2 16 bit interface 65K color (Pin28 65K/262K =Low)

DB	15	14	13	12	11	10	9	8	7	6	5	4	3	2	1	0
	R4	R3	R2	R1	R0	G5	G4	G3	G2	G1	G0	B4	B3	B2	B1	B0

8.9.3 16 bit interface 262K color (Pin28 65K/262K =High)

DB	15	14	13	12	11	10	9	8	7	6	5	4	3	2	1	0
1 st data	X	X	X	X	X	X	X	X	X	X	X	X	X	X	R5	R4
2 nd data	R3	R2	R1	R0	G5	G4	G3	G2	G1	G0	B5	B4	B3	B2	B1	B0

8.9.4 9 bit interface 262K color only (Pin28 65K/262K =High)

DB	15	14	13	12	11	10	9	8	7	6	5	4	3	2	1	0
1 st data	X	X	X	X	X	X	X	R5	R4	R3	R2	R1	R0	G5	G4	G3
2 nd data	X	X	X	X	X	X	X	G2	G1	G0	B5	B4	B3	B2	B1	B0

8.9.5 8 bit interface 65K color (Pin28 65K/262K =Low)

DB	15	14	13	12	11	10	9	8	7	6	5	4	3	2	1	0
1 st data	X	X	X	X	X	X	X	X	R4	R3	R2	R1	R0	G5	G4	G3
2 nd data	X	X	X	X	X	X	X	X	G2	G1	G0	B4	B3	B2	B1	B0

8.9.6 8 bit interface 262K color (Pin28 65K/262K =High)

DB	15	14	13	12	11	10	9	8	7	6	5	4	3	2	1	0
1 st data	X	X	X	X	X	X	X	X							R5	R4
2 nd data	X	X	X	X	X	X	X	X	R3	R2	R1	R0	G5	G4	G3	G2
3 rd data	X	X	X	X	X	X	X	X	G1	G0	B5	B4	B3	B2	B1	B0

9 Register Depiction

Register Address (Hex)	Default (Hex)	DB7	DB6	DB5	DB4	DB3	DB2	DB1	DB0	Remark
00	00	MSB of X-axis start position								
Description	set the horizontals start position of display active region									
Register Address (Hex)	Default (Hex)	DB7	DB6	DB5	DB4	DB3	DB2	DB1	DB0	Remark
01	00	LSB of X-axis start position								
Description	set the horizontals start position of display active region									
Register Address (Hex)	Default (Hex)	DB7	DB6	DB5	DB4	DB3	DB2	DB1	DB0	Remark
02	01	MSB of X-axis end position								
Description	set the horizontals end position of display active region									
Register Address (Hex)	Default (Hex)	DB7	DB6	DB5	DB4	DB3	DB2	DB1	DB0	Remark
03	3F	LSB of X-axis end position								
Description	set the horizontals end position of display active region									
Register Address (Hex)	Default (Hex)	DB7	DB6	DB5	DB4	DB3	DB2	DB1	DB0	Remark
04	00	MSB of Y-axis start position								
Description	set the vertical start position of display active region									
Register Address (Hex)	Default (Hex)	DB7	DB6	DB5	DB4	DB3	DB2	DB1	DB0	Remark
05	00	LSB of Y-axis start position								
Description	Set the vertical start position of display active region									
Register Address (Hex)	Default (Hex)	DB7	DB6	DB5	DB4	DB3	DB2	DB1	DB0	Remark
06	00	MSB of Y-axis end position								
Description	set the vertical end position of display active region									
Register Address (Hex)	Default (Hex)	DB7	DB6	DB5	DB4	DB3	DB2	DB1	DB0	Remark
07	EF	LSB of Y-axis end position								
Description	Set the vertical end position of display active region									

To simplify the address control of display RAM access, the window area address function allows for writing data only within a window area of display RAM specified by registers REG[00]~REG[07].

After writing data to the display RAM, the Address counter will be increased within

setting window address-range which is specified by

MIN X address (REG[0] & REG[1])

MAX X address (REG[2] & REG[3])

MIN Y address (REG[4] & REG[5])

MAX Y address (REG[6] & REG[7])

Therefore, data can be written consecutively without thinking the data address.

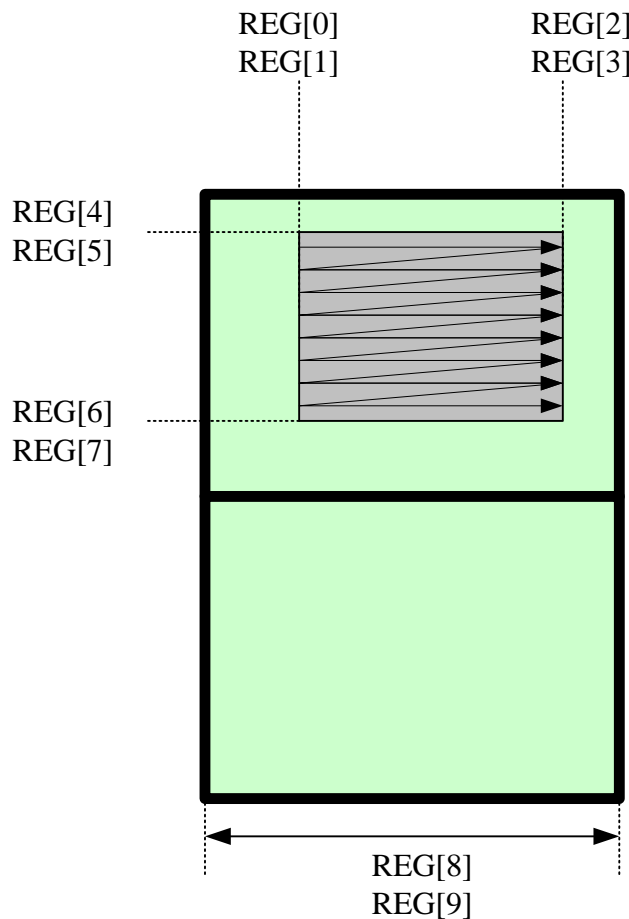

Register Address (Hex)	Default (Hex)	DB7	DB6	DB5	DB4	DB3	DB2	DB1	DB0	Remark
08	01	X	X	X	X	X	X	_PanelXSize H_Byte[1:0]		
Description	Set the panel X size									
Register Address (Hex)	Default (Hex)	DB7	DB6	DB5	DB4	DB3	DB2	DB1	DB0	Remark
09	40	_PanelXSize L_Byte[7:0]								
Description	Set the panel X size									

The register REG[08] and REG[09] is use to calculate the RAM address. If you want to use the TFT as Landscape mode (320x240), the REG[08] & RGE[09] must set to 320. If you want to use the TFT as Portrait mode (240x320), the REG[08] & RGE[09] must set to 240.

Register Address (Hex)	Default (Hex)	DB7	DB6	DB5	DB4	DB3	DB2	DB1	DB0	Remark
0A	00	X	X	X	X	X	[17:16] bits of memory write start address			
Description	Memory write start address									
Register Address (Hex)	Default (Hex)	DB7	DB6	DB5	DB4	DB3	DB2	DB1	DB0	Remark
0B	00	[15:8] bits of memory write start address								
Description	Memory write start address									
Register Address (Hex)	Default (Hex)	DB7	DB6	DB5	DB4	DB3	DB2	DB1	DB0	Remark
0C	00	[7:0] bits of memory write start address								
Description	Memory write start address									

Register Address (Hex)	Default (Hex)	DB7	DB6	DB5	DB4	DB3	DB2	DB1	DB0	Remark
0x10	0x0D	Bit_SWAP	OUT_TEST	BUS_SEL	Blanking	P/S_SEL	CLK_SEL			
Description	<p>"0x10_Clk_sel[1:0]" : The TFT controller built-in 40Mhz PLL clock. These bits are for select the TFT panel dot clock frequency. 00 : 20Mhz 01: 10Mhz 02: 5 Mhz</p> <p>"0x10_ps_sel[2]" : The TFT controller support parallel and serial RGB interface. These bits are for select the output timing. 0 : serial Panel 1: Parallel panel</p> <p>"0x10_blanking_tmp[3]" 0 : OFF (blanking) 1: ON (normal operation)</p> <p>"0x10_bus_sel[5:4]" : It only for serial Panel 00=R , 01=G , 10=B</p> <p>"0x10_out_test[6]" : Self test 0 : normal operation 1: for test (don't use for normal operation) When set the bit to "1" , the Rout=(Reg 2a[6:0]) Gout=(Reg 2b[6:0]) Bout=(Reg 2c[6:0])</p> <p>"0x10_bit_swap[7]" : 0-normal The default setting is suitable for AM320240N1. Don't need to modify it.</p>									
Register Address (Hex)	Default (Hex)	DB7	DB6	DB5	DB4	DB3	DB2	DB1	DB0	Remark
0x11	00	X	X	EVEN			_ODD			
Description	<p>" Even line of serial panel data out sequence or data bus order of parallel panel 000: RGB 001: RBG 010: GRB</p>									

011: GBR 100: BRG 101: BGR Others: reserved Odd line of serial panel data out sequence 000: RGB 001: RBG 010: GRB 011: GBR 100: BRG 101: BGR Others: reserved Must Set to 0x05 for AM320240N1

Register Address (Hex)	Default (Hex)	DB7	DB6	DB5	DB4	DB3	DB2	DB1	DB0	Remark
0x12	00					Hsync_stH_Byte[3:0]				
Description	For TFT output timing adjust: Hsync start position H-Byte The default setting is suitable for AM320240N1. Don't need to modify it.									
Register Address (Hex)	Default (Hex)	DB7	DB6	DB5	DB4	DB3	DB2	DB1	DB0	Remark
0x13	00	Hsync_stL_Byte[7:0]								
Description	For TFT output timing adjust: Hsync start position L-Byte The default setting is suitable for AM320240N1. Don't need to modify it.									
Register Address (Hex)	Default (Hex)	DB7	DB6	DB5	DB4	DB3	DB2	DB1	DB0	Remark
0x14	00					Hsync_pwH_Byte[3:0]				
Description	For TFT output timing adjust: Hsync pulse width H-Byte The default setting is suitable for AM320240N1. Don't need to modify it.									
Register Address (Hex)	Default (Hex)	DB7	DB6	DB5	DB4	DB3	DB2	DB1	DB0	Remark
0x15	10	Hsync_pwL_Byte[7:0]								
Description	For TFT output timing adjust: Hsync pulse width L-Byte The default setting is suitable for AM320240N1. Don't need to modify it.									
Register Address (Hex)	Default (Hex)	DB7	DB6	DB5	DB4	DB3	DB2	DB1	DB0	Remark
0x16	00					Hact_stH_Byte[3:0]				
Description	For TFT output timing adjust: DE pulse start position H-Byte The default setting is suitable for AM320240N1. Don't need to modify it.									

Register Address (Hex)	Default (Hex)	DB7	DB6	DB5	DB4	DB3	DB2	DB1	DB0	Remark
0x17	38	Hact_stL_Byte[7:0]								
Description	For TFT output timing adjust: DE pulse start position L-Byte The default setting is suitable for AM320240N1. Don't need to modify it.									
Register Address (Hex)	Default (Hex)	DB7	DB6	DB5	DB4	DB3	DB2	DB1	DB0	Remark
0x18	01	Hact_pwH_Byte[3:0]								
Description	For TFT output timing adjust: DE pulse width H-Byte The default setting is suitable for AM320240N1. Don't need to modify it.									
Register Address (Hex)	Default (Hex)	DB7	DB6	DB5	DB4	DB3	DB2	DB1	DB0	Remark
0x19	40	Hact_pwL_Byte[7:0]								
Description	For TFT output timing adjust: DE pulse width L-Byte The default setting is suitable for AM320240N1. Don't need to modify it.									

Register Address (Hex)	Default (Hex)	DB7	DB6	DB5	DB4	DB3	DB2	DB1	DB0	Remark
0x1A	01	HtotalH_Byte[3:0]								
Description	For TFT output timing adjust: Hsync total clocks H-Byte The default setting is suitable for AM320240N1. Don't need to modify it.									
Register Address (Hex)	Default (Hex)	DB7	DB6	DB5	DB4	DB3	DB2	DB1	DB0	Remark
0x1B	B8	HtotalL_Byte[7:0]								
Description	For TFT output timing adjust: Hsync total clocks H-Byte The default setting is suitable for AM320240N1. Don't need to modify it.									
Register Address (Hex)	Default (Hex)	DB7	DB6	DB5	DB4	DB3	DB2	DB1	DB0	Remark
0x1C	00	Vsync_stH_Byte[3:0]								
Description	For TFT output timing adjust: Vsync start position H-Byte The default setting is suitable for AM320240N1. Don't need to modify it.									
Register Address (Hex)	Default (Hex)	DB7	DB6	DB5	DB4	DB3	DB2	DB1	DB0	Remark

0x1D	00	Vsync_stL_Byte[7:0]								
Description	For TFT output timing adjust: Vsync start position L-Byte The default setting is suitable for AM320240N1. Don't need to modify it.									
Register Address (Hex)	Default (Hex)	DB7	DB6	DB5	DB4	DB3	DB2	DB1	DB0	Remark
0x1E	00	Vsync_pwH_Byte[3:0]								
Description	For TFT output timing adjust: Vsync pulse width H-Byte The default setting is suitable for AM320240N1. Don't need to modify it.									
Register Address (Hex)	Default (Hex)	DB7	DB6	DB5	DB4	DB3	DB2	DB1	DB0	Remark
0x1F	08	Vsync_pwL_Byte[7:0]								
Description	For TFT output timing adjust: Vsync pulse width L-Byte The default setting is suitable for AM320240N1. Don't need to modify it.									
Register Address (Hex)	Default (Hex)	DB7	DB6	DB5	DB4	DB3	DB2	DB1	DB0	Remark
0x20	00	Vact_stH_Byte[3:0]								
Description	For TFT output timing adjust: Vertical DE pulse start position H-Byte The default setting is suitable for AM320240N1. Don't need to modify it.									
Register Address (Hex)	Default (Hex)	DB7	DB6	DB5	DB4	DB3	DB2	DB1	DB0	Remark
0x21	12	Vact_stL_Byte[7:0]								
Description	For TFT output timing adjust: Vertical DE pulse start position L-Byte The default setting is suitable for AM320240N1. Don't need to modify it.									
Register Address (Hex)	Default (Hex)	DB7	DB6	DB5	DB4	DB3	DB2	DB1	DB0	Remark
0x22	00	Vact_pwH_Byte[3:0]								
Description	For TFT output timing adjust: Vertical Active width H-Byte The default setting is suitable for AM320240N1. Don't need to modify it.									
Register Address (Hex)	Default (Hex)	DB7	DB6	DB5	DB4	DB3	DB2	DB1	DB0	Remark
0x23	F0	Vact_pwL_Byte[7:0]								
Description	For TFT output timing adjust: Vertical Active width H-Byte The default setting is suitable for AM320240N1. Don't need to modify it.									
Register Address (Hex)	Default (Hex)	DB7	DB6	DB5	DB4	DB3	DB2	DB1	DB0	Remark
0x24	01	VtotalH_Byte[3:0]								

Description	For TFT output timing adjust: Vertical total width H-Byte The default setting is suitable for AM320240N1. Don't need to modify it.									
Register Address (Hex)	Default (Hex)	DB7	DB6	DB5	DB4	DB3	DB2	DB1	DB0	Remark
0x25	09	VtotalL_Byte[7:0]								
Description	For TFT output timing adjust: Vertical total width L-Byte The default setting is suitable for AM320240N1. Don't need to modify it.									

Register Address (Hex)	Default (Hex)	DB7	DB6	DB5	DB4	DB3	DB2	DB1	DB0	Remark
26	00	X	X	X	X	X	[17:16] bits of memory read start address			
Description	Memory read start address									
Register Address (Hex)	Default (Hex)	DB7	DB6	DB5	DB4	DB3	DB2	DB1	DB0	Remark
27	00	[15:8] bits of memory write start address								
Description	Memory read start address									
Register Address (Hex)	Default (Hex)	DB7	DB6	DB5	DB4	DB3	DB2	DB1	DB0	Remark
28	00	[7:0] bits of memory write start address								
Description	Memory read start address									

Register Address (Hex)	Default (Hex)	DB7	DB6	DB5	DB4	DB3	DB2	DB1	DB0	Remark
29	00	[7:1] Reversed								
Description	[0] Load output timing related setting (H sync., V sync. and DE) to take effect									

Register Address (Hex)	Default (Hex)	DB7	DB6	DB5	DB4	DB3	DB2	DB1	DB0	Remark	
0x2A	00	X	TestPatternRout[6:0]								
Description	When " REG[0x10]_out_test[6]" : Self test =1 ; The Rout data equal to TestPatternRout[6:0]										
Register Address (Hex)	Default (Hex)	DB7	DB6	DB5	DB4	DB3	DB2	DB1	DB0	Remark	
0x2B	00	X	TestPatternGout[6:0]								

Description	When " REG[0x10]_out_test[6]" : Self test =1 ; The Gout data equal to TestPatternGout[6:0]									
Register Address (Hex)	Default (Hex)	DB7	DB6	DB5	DB4	DB3	DB2	DB1	DB0	Remark
0x2C	00	X	TestPatternBout[6:0]							
Description	When " REG[0x10]_out_test[6]" : Self test =1 ; The Bout data equal to TestPatternBout[6:0]									

If you set the " REG[0x10]_out_test[6]" : Self test =1 , the TFT controller will skip the connect of the display RAM. The Output port will send the REG[2A] ,REG[2B],REG[2C] data.

REG[2A]=0x3F
REG[2B]=0x00
REG[2C]=0x00

REG[2A]=0x00
REG[2B]=0x3F
REG[2C]=0x00

REG[2A]=0x00
REG[2B]=0x00
REG[2C]=0x3F

Register Address (Hex)	Default (Hex)	DB7	DB6	DB5	DB4	DB3	DB2	DB1	DB0	Remark
0x2D	00	X	X	X	X	[3]	Rising/falling edge[2]	_rotate [1:0]		
Description	[3] Output pin X_DCON level control ; TFT Power ON/OFF control 0: TFT POWER circuit OFF 1: TFT POWER circuit ON Rising/falling edge[2] : 0: The RGB out put data are on the Rising edge of the DCLK. 1: The RGB out put data are on the Falling edge of the DCLK. _rotate [1:0]: 00 : rotate 0 degree 01 : rotate 90 degree 10 : rotate 270 degree 11 : rotate 180 degree									

Register Address (Hex)	Default (Hex)	DB7	DB6	DB5	DB4	DB3	DB2	DB1	DB0	Remark
30	00	X	X	X	X	X	_H byte H-Offset[3:0]			
Description	Set the Horizontal offset									
Register Address (Hex)	Default (Hex)	DB7	DB6	DB5	DB4	DB3	DB2	DB1	DB0	Remark
31	00	_L byte H-Offset[7:0]								
Description	Set the Horizontal offset									

Register Address (Hex)	Default (Hex)	DB7	DB6	DB5	DB4	DB3	DB2	DB1	DB0	Remark
32	00	X	X	X	X	X	_H byte V-Offset[3:0]			
Description	Set the Vertical offset									
Register Address (Hex)	Default (Hex)	DB7	DB6	DB5	DB4	DB3	DB2	DB1	DB0	Remark
33	00	_L byte V-Offset[7:0]								
Description	Set the Vertical offset									

Register Address (Hex)	Default (Hex)	DB7	DB6	DB5	DB4	DB3	DB2	DB1	DB0	Remark
34	00	[7:4] Reserved					_H byte H-def[3:0]			
Description	[3:0] MSB of image horizontal physical resolution in memory									
Register Address (Hex)	Default (Hex)	DB7	DB6	DB5	DB4	DB3	DB2	DB1	DB0	Remark
35	40	_L byte H-def[7:0]								
Description	[7:0] LSB of image horizontal physical resolution in memory									

Register Address (Hex)	Default (Hex)	DB7	DB6	DB5	DB4	DB3	DB2	DB1	DB0	Remark
36	01	[7:4] Reserved					_H byte V-def[3:0]			
Description	[3:0] MSB of image vertical physical resolution in memory									
Register Address (Hex)	Default (Hex)	DB7	DB6	DB5	DB4	DB3	DB2	DB1	DB0	Remark
37	E0	_L byte V-def[7:0]								
Description	[7:0] LSB of image vertical physical resolution in memory									

The total RAM size is 640x240x18bit. The user can arrange the Horizontal ram size by REG[34],REG[35] and the Vertical ram size by REG[36],REG[37].

EX: 320x480x18bit REG[34]=0x01 , REG[35]=0x40 , REG[36]=0x01 , REG[37]=0xE0

EX: 640x240x18bit. REG[34]=0x02 , REG[35]=0x80 , REG[36]=0x00 , REG[37]=0xF0

DISPLAYED COLOR AND INPUT DATA

	Color & Gray Scale	DATA SIGNAL																	
		R5	R4	R3	R2	R1	R0	G5	G4	G3	G2	G1	G0	B5	B4	B3	B2	B1	B0
Basic Color	Black	0	0	0	0	0	0	0	0	0	0	0	0	0	0	0	0	0	0
	Red(0)	1	1	1	1	1	1	0	0	0	0	0	0	0	0	0	0	0	0
	Green(0)	0	0	0	0	0	0	0	1	1	1	1	1	0	0	0	0	0	0
	Blue(0)	0	0	0	0	0	0	0	0	0	0	0	0	1	1	1	1	1	1
	Cyan	0	0	0	0	0	0	1	1	1	1	1	1	1	1	1	1	1	1
	Magenta	1	1	1	1	1	1	0	0	0	0	0	0	1	1	1	1	1	1
	Yellow	1	1	1	1	1	1	1	1	1	1	1	1	0	0	0	0	0	0
White	1	1	1	1	1	1	1	1	1	1	1	1	1	1	1	1	1	1	
Red	Black	0	0	0	0	0	0	0	0	0	0	0	0	0	0	0	0	0	0
	Red(62)	0	0	0	0	0	1	0	0	0	0	0	0	0	0	0	0	0	0
	Red(61)	0	0	0	0	1	0	0	0	0	0	0	0	0	0	0	0	0	0
	:	:	:	:	:	:	:	:	:	:	:	:	:	:	:	:	:	:	:
	Red(31)	0	1	1	1	1	1	0	0	0	0	0	0	0	0	0	0	0	0
	:	:	:	:	:	:	:	:	:	:	:	:	:	:	:	:	:	:	:
	Red(1)	1	1	1	1	1	0	0	0	0	0	0	0	0	0	0	0	0	0
Red(0)	1	1	1	1	1	1	0	0	0	0	0	0	0	0	0	0	0	0	
Green	Black	0	0	0	0	0	0	0	0	0	0	0	0	0	0	0	0	0	0
	Green(62)	0	0	0	0	0	0	0	0	0	0	0	1	0	0	0	0	0	0
	Green(61)	0	0	0	0	0	0	0	0	0	0	1	0	0	0	0	0	0	0
	:	:	:	:	:	:	:	:	:	:	:	:	:	:	:	:	:	:	:
	Green(31)	0	0	0	0	0	0	0	1	1	1	1	0	0	0	0	0	0	0
	:	:	:	:	:	:	:	:	:	:	:	:	:	:	:	:	:	:	:
	Green(1)	0	0	0	0	0	0	1	1	1	1	1	0	0	0	0	0	0	0
Green(0)	0	0	0	0	0	0	1	1	1	1	1	1	0	0	0	0	0	0	
Blue	Black	0	0	0	0	0	0	0	0	0	0	0	0	0	0	0	0	0	0
	Blue(62)	0	0	0	0	0	0	0	0	0	0	0	0	0	0	0	0	0	1
	Blue(61)	0	0	0	0	0	0	0	0	0	0	0	0	0	0	0	0	1	0
	:	:	:	:	:	:	:	:	:	:	:	:	:	:	:	:	:	:	:
	Blue(31)	0	0	0	0	0	0	0	0	0	0	0	0	0	1	1	1	1	1
	:	:	:	:	:	:	:	:	:	:	:	:	:	:	:	:	:	:	:
	Blue(1)	0	0	0	0	0	0	0	0	0	0	0	0	1	1	1	1	1	0
Blue(0)	0	0	0	0	0	0	0	0	0	0	0	0	1	1	1	1	1	1	

10 RELIABILITY TEST CONDITIONS

Test Item	Test Conditions	Note
High Temperature Operation	70±3°C , t=240 hrs	
Low Temperature Operation	-20±3°C , t=240 hrs	
High Temperature Storage	80±3°C , t=240 hrs	(1),(2)
Low Temperature Storage	-30±3°C , t=240 hrs	(1),(2)
Storage Humidity Test	60 °C, Humidity 90%, 240 hrs	(1),(2)
Vibration Test (Packing)	Sweep frequency : 10 ~ 50 ~ 10 Hz/1min Amplitude : 0.75mm Test direction : X.Y.Z/3 axis Duration : 30min/each axis	(2)

Note(1) Condensation of water is not permitted on the module.

Note(2) The module should be inspired after 1 hour storage in normal conditions (15~35 °C , 45~65%RH).

Note(3) The module shouldn't be tested over one condition, and all the tests are independent.

Note(4) All reliability tests should be done without the protective film.

Definitions of life end point:

- Current drain should be smaller than the specific value.
- Function of the module should be maintained.
- Appearance and display quality should not have degraded noticeably.
- Contrast ratio should be greater than 50% of initial value.

11 USE PRECAUTIONS

11.1 Handling precautions

- 1) The polarizing plate may break easily so be careful when handling it. Do not touch, press or rub it with a hard-material tool like tweezers.
- 2) Do not touch the polarizing plate surface with bare hands so as not to make it dirty. If the surface or other related part of the polarizing plate is dirty, soak a soft cotton cloth or chamois leather in benzine and wipe off with it. Do not use chemical liquids such as acetone, toluene and isopropyl alcohol. Failure to do so may bring chemical reaction phenomena and deteriorations.
- 3) Remove any spit or water immediately. If it is left for hours, the suffered part may deform or decolorize.
- 4) If the LCD element breaks and any LC stuff leaks, do not suck or lick it. Also if LC stuff is stuck on your skin or clothing, wash thoroughly with soap and water immediately.

11.2 Installing precautions

- 1) The PCB has many ICs that may be damaged easily by static electricity. To prevent breaking by static electricity from the human body and clothing, earth the human body properly using the high resistance and discharge static electricity during the operation. In this case, however, the resistance value should be approx. $1M\Omega$ and the resistance should be placed near the human body rather than the ground surface. When the indoor space is dry, static electricity may occur easily so be careful. We recommend the indoor space should be kept with humidity of 60% or more. When a soldering iron or other similar tool is used for assembly, be sure to earth it.
- 2) When installing the module and ICs, do not bend or twist them. Failure to do so may crack LC element and cause circuit failure.
- 3) To protect LC element, especially polarizing plate, use a transparent protective plate (e.g., acrylic plate, glass etc) for the product case.
- 4) Do not use an adhesive like a both-side adhesive tape to make LCD surface (polarizing plate) and product case stick together. Failure to do so may cause the polarizing plate to peel off.

11.3 Storage precautions

- 1) Avoid a high temperature and humidity area. Keep the temperature between 0°C and 35°C and also the humidity under 60%.
- 2) Choose the dark spaces where the product is not exposed to direct sunlight or fluorescent light.
- 3) Store the products as they are put in the boxes provided from us or in the same

conditions as we recommend.

11.4 Operating precautions

- 1) Do not boost the applied drive voltage abnormally. Failure to do so may break ICs. When applying power voltage, check the electrical features beforehand and be careful. Always turn off the power to the LC module controller before removing or inserting the LC module input connector. If the input connector is removed or inserted while the power is turned on, the LC module internal circuit may break.
- 2) The display response may be late if the operating temperature is under the normal standard, and the display may be out of order if it is above the normal standard. But this is not a failure; this will be restored if it is within the normal standard.
- 3) The LCD contrast varies depending on the visual angle, ambient temperature, power voltage etc. Obtain the optimum contrast by adjusting the LC drive voltage.
- 4) When carrying out the test, do not take the module out of the low-temperature space suddenly. Failure to do so will cause the module condensing, leading to malfunctions.
- 5) Make certain that each signal noise level is within the standard (L level: $0.2V_{dd}$ or less and H level: $0.8V_{dd}$ or more) even if the module has functioned properly. If it is beyond the standard, the module may often malfunction. In addition, always connect the module when making noise level measurements.
- 6) The CMOS ICs are incorporated in the module and the pull-up and pull-down function is not adopted for the input so avoid putting the input signal open while the power is ON.
- 7) The characteristic of the semiconductor element changes when it is exposed to light emissions, therefore ICs on the LCD may malfunction if they receive light emissions. To prevent these malfunctions, design and assemble ICs so that they are shielded from light emissions.
- 8) Crosstalk occurs because of characteristics of the LCD. In general, crosstalk occurs when the regularized display is maintained. Also, crosstalk is affected by the LC drive voltage. Design the contents of the display, considering crosstalk.

11.5 Other

- 1) Do not disassemble or take the LC module into pieces. The LC modules once disassembled or taken into pieces are not the guarantee articles.
- 2) The residual image may exist if the same display pattern is shown for hours. This residual image, however, disappears when another display pattern is shown or the drive is interrupted and left for a while. But this is not a problem on reliability.
- 3) AMIPRE will provide one year warranty for all products and three months warranty for all repairing products.

12 OUTLINE DIMENSION

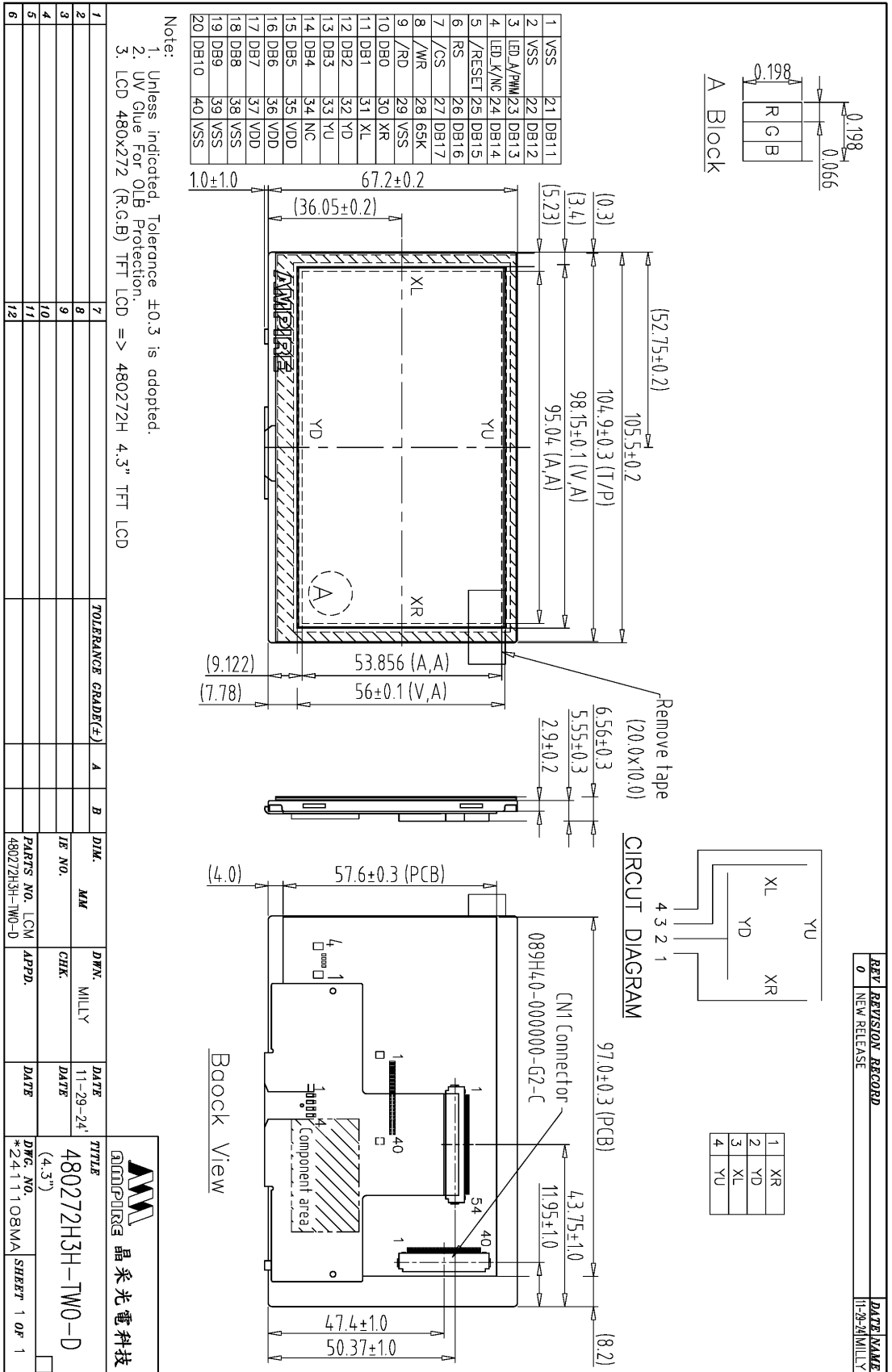

13 Package

REVISION RECORD	DATE MADE
0 NEW RELEASE	09-03-14

Size: LxHxW
(452.0x347.0x175.0mm)
ERP No.:9000000070

3	4802720C/NU/ND系列
2	4802720系列
1	4802721系列
適用品號	

AMPIRE 晶采光電科技

480272H3 (4.3")

DWG. NO. *140908SA SHEET 1 OF 1

1	交差排蓋	7	TOLERANCE GRAD(%)	A	B	DIM.	MM	DWN.	SNOW	DATE	09-03-14
2		8				IE NO.		CHK.		DATE	
3		9				PARTS NO. BOX	480272H3	APPL.		DATE	
4		10									
5		11									
6		12									

Note:
 1 Tray=3x3=9Pcs.
 2 ESD BAG=8xTray=72Pcs. (9 Tray)