

Maxell Lead-Free Oxygen Sensors KE-LF Series

Features:

- * Lead-free galvanic cell-type sensor
 - no external power supply required for sensor operation
 - no warmup time required
 - meets RoHS2 directive
- * Weak acid electrolyte
 - virtually no influence from CO₂, H₂S, SO₂
 - long life - 3~10 years in ambient air

Applications:

- * Safety - Oxygen detectors
- * Environmental controls - Combustion gas monitoring
- * Food industry - Refrigeration, greenhouses
- * Educational material - Oxygen test kits
- * Medical - Artificial ventilator

The Maxell Oxygen Sensor KE-LF Series are unique galvanic cell-type oxygen sensors developed by Maxell, Ltd. in Japan. Their most notable features are lead-free, long life expectancy, excellent chemical durability, and no influence by CO₂. KE-LF Series oxygen sensors are ideal to meet the ever-increasing demand for oxygen monitoring in various fields such as combustion gas monitoring, the biochemical field, domestic combustion appliances, etc.



Sensitivity Characteristics:

(typical values)

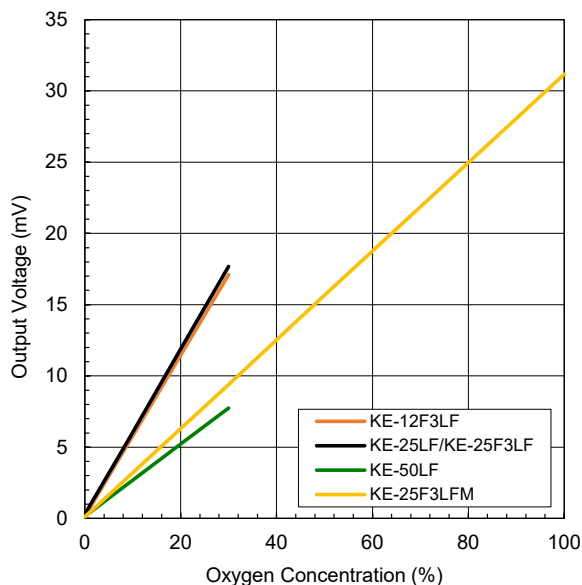

Response time:

(typical)

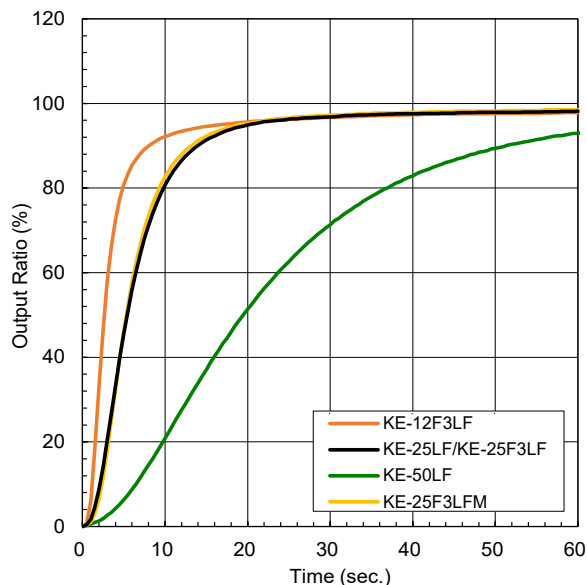

Dimensions:

KE-25LF / KE-50LF
(standard version)

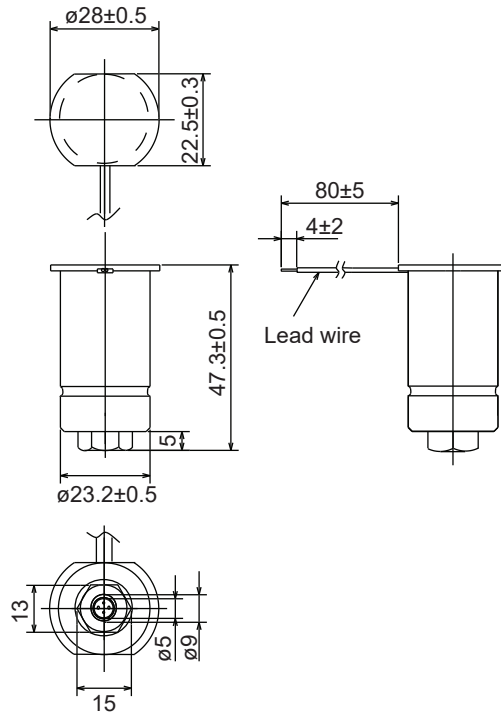

KE-12F3LF / KE-25F3LF / KE-25F3LFM
(threaded top)

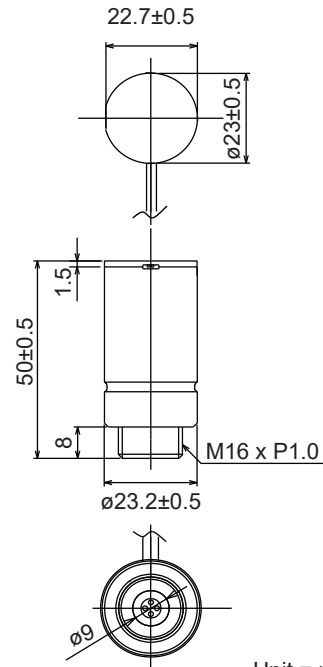

Unit = mm

Specifications:

Item	Model			
	KE-12F3LF	KE-25LF KE-25F3LF	KE-50LF	KE-25F3LFM
Measurement range	0~30% O ₂			0~100% O ₂
Accuracy (Note 1)	±1% full scale	±1% full scale	±2% full scale	±1% full scale
Operating conditions	Atmospheric pressure	811hPa~1216hPa		
	Temperature	5~40°C		
	Relative humidity	10~90%RH (no condensation)		
Response time (90%) (Note 2)	approx 8 sec.	approx 15 sec.	approx 60 sec.	approx 15 sec.
Initial output voltage under factory std test conditions	9.0~15.0mV	10.0~15.5mV	4.5~7.5mV	5.0~8.0mV
Life expectancy at 20°C in normal air (Note 3)	approx 3 yrs	approx 5 yrs	approx 10 yrs	approx 6 yrs
Factory test conditions	Test gas	21% O ₂		
	Atmospheric pressure	1013hPa		
	Temperature	25°C		

Notes:

1) When calibrated at both 0% and 30% of O₂, accuracy in the range from 0-30% O₂ shall be within ±1% of full scale for both KE-12F3LF and KE-25LF/KE-25F3LF, and ±2% of full scale for KE-50LF. When calibrated at both 0% and 100% of O₂, accuracy in the range from 0-100% O₂ shall be within ±1% of full scale for KE-25F3LFM.

2) Sensors should be used under conditions where the air exchange is greater than 200~300ml per minute in order to obtain the response speed as shown in the Specifications.

3) Life expectancy at 20°C in normal air (1013hPa / 21%O₂) is defined as the period until sensor output drops to 70% of its original value.

* Please refer to the Limited Warranty and Limitation of Liability in *Technical Information for Maxell Oxygen Sensor KE-LF Series*.

* KE-LF series oxygen sensors are designed, manufactured and tested for industrial application only. These products are not designed, manufactured, tested, or intended specifically for use in or incorporation into artificial respirators, ventilators, and/or other equipment for medical application, or subassembly modules or parts thereof.

Manufacturer: Maxell, Ltd.
 Distributor: FIGARO ENGINEERING INC.
 1-5-11 Senba-nishi
 Mino, Osaka 562-8505 JAPAN
 Tel: 81-72-728-2045
 URL: www.figaro.co.jp/en/