

Introduction

The ATA8510 Curiosity Board provides an efficient, low-cost development platform for evaluating and demonstrating the features and functionalities of Microchip's ATA8510, a low-power sub-GHz RF transceiver within the RF board mounted on the curiosity board. The ATA8510 Curiosity Board serves as a wireless (sub-GHz) development platform that supports rapid prototyping using on-chip microcontroller peripherals. The ATA8510 Curiosity Board supports 418–477 MHz band. User can power the ATA8510 Curiosity Board via USB Type-C™ without requiring additional hardware accessories in the Standalone mode. The ATA8510 Curiosity Board also complies with the mikroBUS™ specifications. Plug the board onto the host board and control it using the host Microcontroller Unit (MCU) with Serial Peripheral Interface (SPI) commands in the Host mode. The In-System Programming (ISP) Interface is available for programming purposes. The ATA8510 Curiosity Board supports a variety of application development, such as smart home systems, industrial automation, Internet of Things (IoT), Garage Door Opening (GDO), and other similar applications.

Features

- ATA8510 Sub-GHz RF Transceiver and 24.305 MHz Crystal within the ATA8510 RF Board Mounted on the Curiosity Board
- Supports both 3.3V and 5V Power Supply (Either Derived from USB Type-C™ or Sourced from Host Board Using mikroBUS™ Interface)
- Provides a mikroBUS Header to Interface with Host Board Supporting mikroBUS Socket
- On-board 5V to 3.3V Low-Dropout Regulator (LDO) Based on MCP1727
- Two User LEDs
- Two Power Indication LEDs
- One User-Configurable Switch
- One Reset Switch
- One 20-Pin Header to Access Pins of ATA8510 SoC
- ISP Header for External Programmer/Debugger, such as ATMEL-ICE and PICKIT™ 5

Table of Contents

Introduction.....	1
Features.....	1
1. Quick References.....	3
1.1. Reference Documentation.....	3
1.2. Hardware Prerequisites.....	3
1.3. Software Prerequisites.....	3
1.4. Acronyms and Abbreviations.....	3
2. Kit Overview.....	5
2.1. Kit Contents.....	6
3. Hardware.....	7
3.1. Power Supply.....	7
3.2. In-System Programming (ISP) Header (J104).....	9
3.3. Mode of Operation.....	10
3.4. USB Connectivity.....	13
3.5. Switches	13
3.6. LEDs.....	13
3.7. 20-Pin Header (J200).....	13
4. ATA8510 Curiosity Board Out-of-the-Box Demo.....	16
5. Appendix A: Reference Circuit.....	17
5.1. ATA8510 Curiosity Board Reference Schematics.....	17
5.2. ATA8510 Curiosity Board Bill of Materials.....	20
6. Appendix-B: PCB Antenna and RF Considerations.....	21
6.1. RF Performance with Host Board.....	23
7. Appendix C: Regulatory Approval.....	24
7.1. United States.....	24
7.2. Canada.....	25
7.3. Europe.....	25
8. Document Revision History.....	26
Microchip Information.....	27
Trademarks.....	27
Legal Notice.....	27
Microchip Devices Code Protection Feature.....	27
Product Page Links.....	28

1. Quick References

1.1. Reference Documentation

For further details, refer to the following:

- [ATA8510/15 Industrial User's Guide \(DS50003142\)](#)
- [ATA8510/15 Industrial Data Sheet \(DS70005505\)](#)
- [ATMEL-ICE User Guide \(42330C\)](#)
- [ATAN0096 ATA8510 Programmer's Guide Application Note \(9346\)](#)
- [ATA8510 Application Developer's Guide](#)
- [mikroBUS™ Specification \(mikrobus\)](#)
- [MPLAB® PICkit™ 5 In-Circuit Debugger User's Guide \(DS50003525\)](#)

1.2. Hardware Prerequisites

- ATA8510 Curiosity Board Kit ([EV82M22A](#))
- WBZ451HPE Curiosity Board ([EV79Y91A](#))⁽¹⁾
- SAM C21 Xplained Pro Evaluation Kit ([ATSAMC21-XPRO](#))⁽²⁾
- mikroBUS™ Adapter ([ATMBUSADAPTER-XPRO](#))⁽²⁾
- Type-A USB to Type-C™ USB Cable
- ATMEL-ICE Programmer ([ATATMEL-ICE](#)) or MPLAB® PICkit™ 5 In-Circuit Debugger ([PG164150](#))

Notes:

1. If using ATA8510 Curiosity Board in the Host mode with WBZ451HPE Curiosity Board as host.
2. If using ATA8510 Curiosity Board in the Host mode with SAM C21 Xplained Pro Evaluation Kit as host.
3. For more details on the host boards supported by the ATA8510 Curiosity Board, refer to the *Example Application* section in the [ATA8510 Application Developer's Guide](#).

1.3. Software Prerequisites

- EEPROM Config Tool
Note: For the latest version of EEPROM Config Tool, go to www.microchip.com.
- MPLAB® X Integrated Development Environment ([MPLAB X IDE](#))
- Microchip Studio for AVR and SAM Devices ([Microchip Studio](#))
- ATA8510 Curiosity Board Out-of-the-Box (OOB) Demo ([ATA8510_Curiosity_OOB](#))

1.4. Acronyms and Abbreviations

Table 1-1. Acronyms and Abbreviations

Acronyms and Abbreviations	Description
BOM	Bill of Material
DNP	Do Not Populate
EVB	Evaluation Board
GDO	Garage Door Opener
GPIO	General Purpose Input Output
GUI	Graphical User Interface

Table 1-1. Acronyms and Abbreviations (continued)

Acronyms and Abbreviations	Description
I ² C/I2C	Inter-Integrated Circuit
IDE	Integrated Development Environment
IoT	Internet of Things
ISP	In-System Programming
LDO	Low-Dropout Regulator
LED	Light Emitting Diode
MCU	Microcontroller Unit
NC	Not Connected
OOB	Out of Box
PCB	Printed Circuit Board
RF	Radio Frequency
RSSI	Received Signal Strength Indicator
RX	Receive
SMD	Surface Mount Device
SoC	System-on-Chip
SPI	Serial Peripheral Interface
TX	Transmit
UART	Universal Asynchronous Receiver-Transmitter
XPRO	Xplained PRO Expansion Header

2. Kit Overview

The ATA8510 Curiosity Board contains an ATA8510 SoC, which is a sub-GHz RF transceiver with an integrated AVR microcontroller within the ATA8510 RF board. All the signals from the ATA8510 are brought onto the Curiosity Board, where they are connected to on-board peripherals or terminated onto headers for rapid prototyping or evaluation.

Figure 2-1. ATA8510 Curiosity Board (EV82M22A) (Top View)

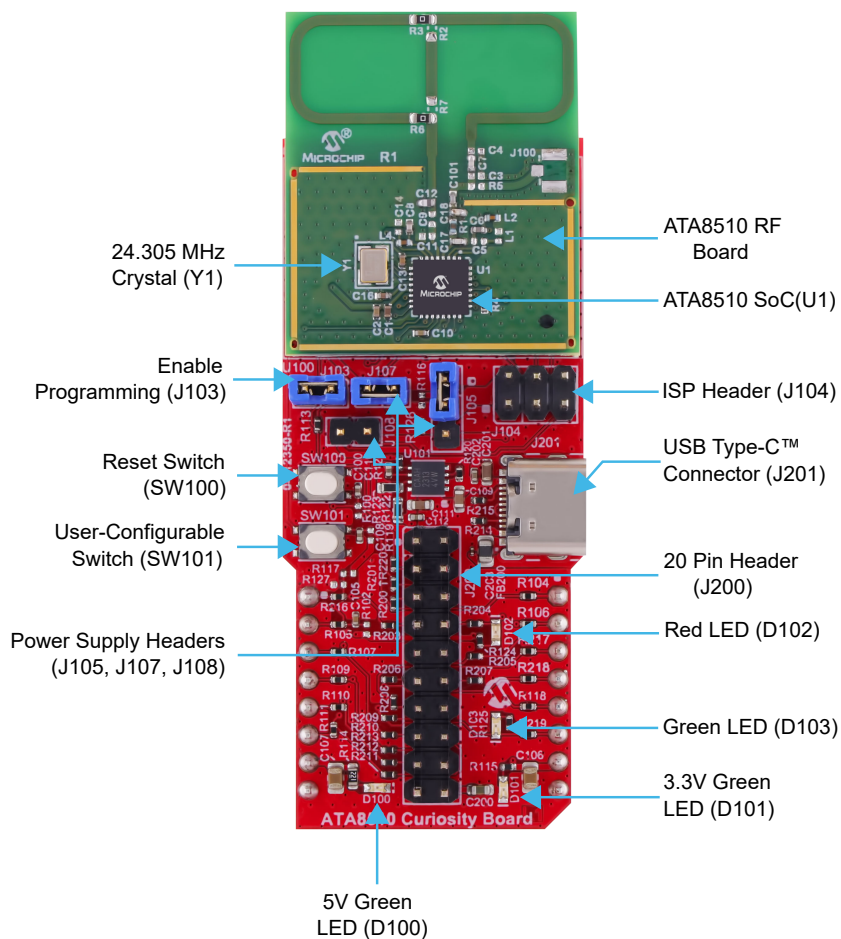
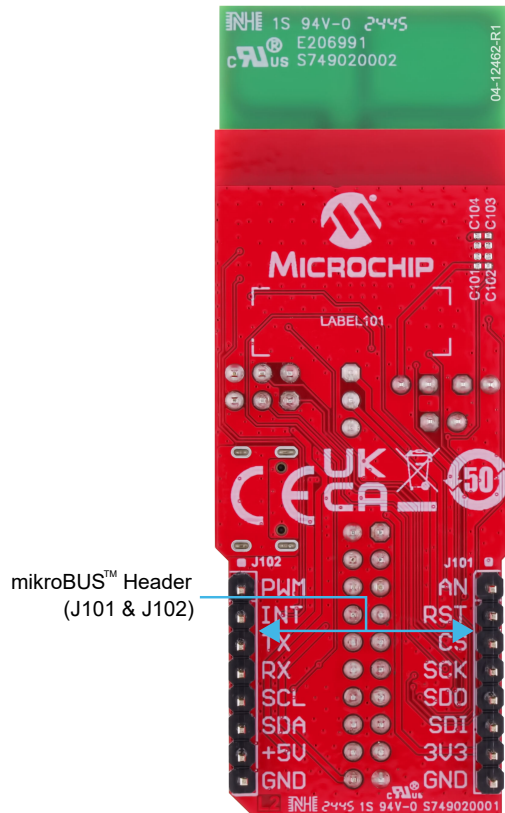

Figure 2-2. ATA8510 Curiosity Board (EV82M22A) (Bottom View)



2.1. Kit Contents

The EV82M22A (ATA8510 Curiosity Board) Kit contains the following:

- ATA8510 Curiosity Board

Notes:

1. To evaluate sub-GHz TX/RX functionality, obtain two identical kits. Designate one kit as the transmitter and the other as the receiver. For more details, refer to the steps in the [ATA8510 Curiosity Board Out-of-the-Box Demo](#).
2. If any of the above items are missing in the kit, go to <http://support.microchip.com> or contact your local Microchip Sales office via the [Global Sales and Distribution](#) page.

3. Hardware

This section describes the hardware features of the ATA8510 Curiosity Board.

Figure 3-1. ATA8510 Curiosity Board Block Diagram

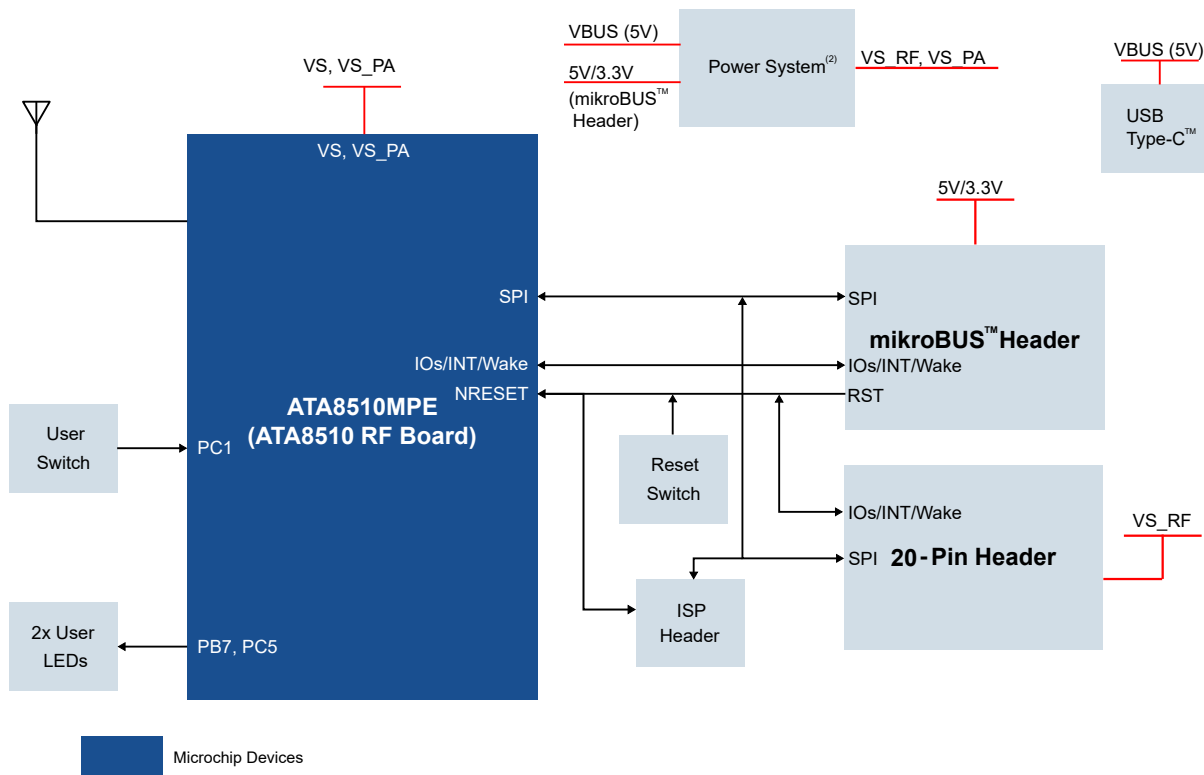

Notes:

1. Microchip's total system solution includes complementary devices, software drivers, and reference designs, which is highly recommended to ensure the proven performance of the ATA8510 Curiosity Board. For more details, go to support.microchip.com or contact your local Microchip Sales office.
2. For more details on manufacturer part number and description, refer to the following table.

Table 3-1. Microchip Components used in ATA8510 Curiosity Board

S.No.	Designator	Manufacturer Part Number	Description
1	U101	MCP1727T-ADJE/MF	MCHP Analog LDO 0.8V-5V MCP1727T-ADJE/MF DFN-8

3.1. Power Supply

The ATA8510 Curiosity Board can be powered using any of the following sources, depending on the use case scenario:

- USB Type-C™ Connector ([J201](#))
- Host Board Supporting mikroBUS™ Socket ([J101](#), [J102](#))

Table 3-2. Power Supply Sources

Power Supply Source	Voltage Operation	Jumper Configuration	Notes
USB Type-C™ (Standalone mode)	3.3V (default)	<ul style="list-style-type: none"> Jumper connected between J105-1 and J105-2 Jumper mounted on J107 	<ul style="list-style-type: none"> USB supplies 5V to LDO MCP1727 (U101) to generate 3.3V for ATA8510 RF board. Do not mount jumper on J108.
	5V	<ul style="list-style-type: none"> Jumper mounted on J108 Jumper mounted between J105-3 and J105-2 	<ul style="list-style-type: none"> Do not mount jumper on J107.
Host board mikroBUS™ socket (Host mode)	3.3V	<ul style="list-style-type: none"> Jumper connected between J105-1 and J105-2 Jumper mounted on J107 	<ul style="list-style-type: none"> Do not mount jumper on J108.
	5V	<ul style="list-style-type: none"> Jumper mounted between J105-3 and J105-2 	<ul style="list-style-type: none"> Do not mount jumper on J107 and J108.

The following figure illustrates the jumper positions that power the ATA8510 Curiosity Board.

Figure 3-2. Jumper Configuration for Power Input

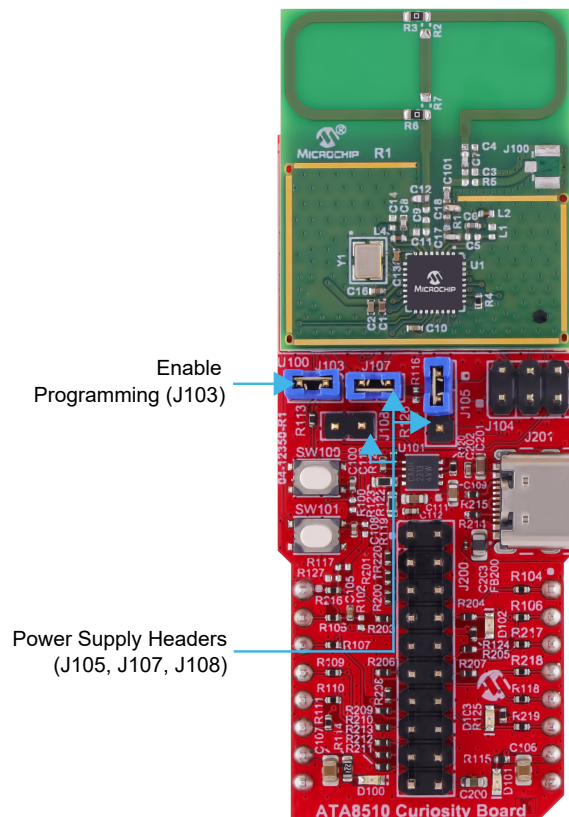
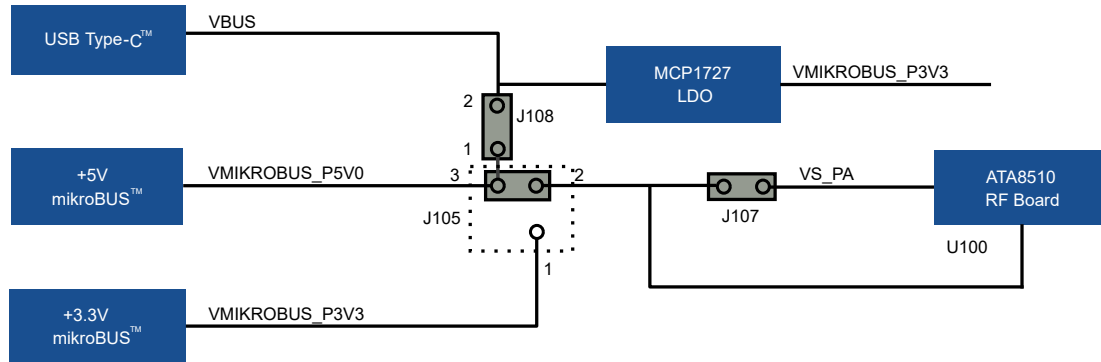

Figure 3-3. Power Tree Diagram



3.2. In-System Programming (ISP) Header (J104)

The ISP header (J104) is a standard 2x3-pin header. It allows in-circuit emulation and debugging using Microchip’s in-circuit emulator tools, and it allows direct programming of the ATA8510 SoC. The ISP header supports external debuggers, such as ATMEL-ICE. The following figure illustrates the connection between the ICSP header, external debuggers, and the ATA8510 Curiosity Board.

Note: Ensure that the jumper is placed on header J103 between pins 1 and 2 during programming.

Figure 3-4. Connection Diagram

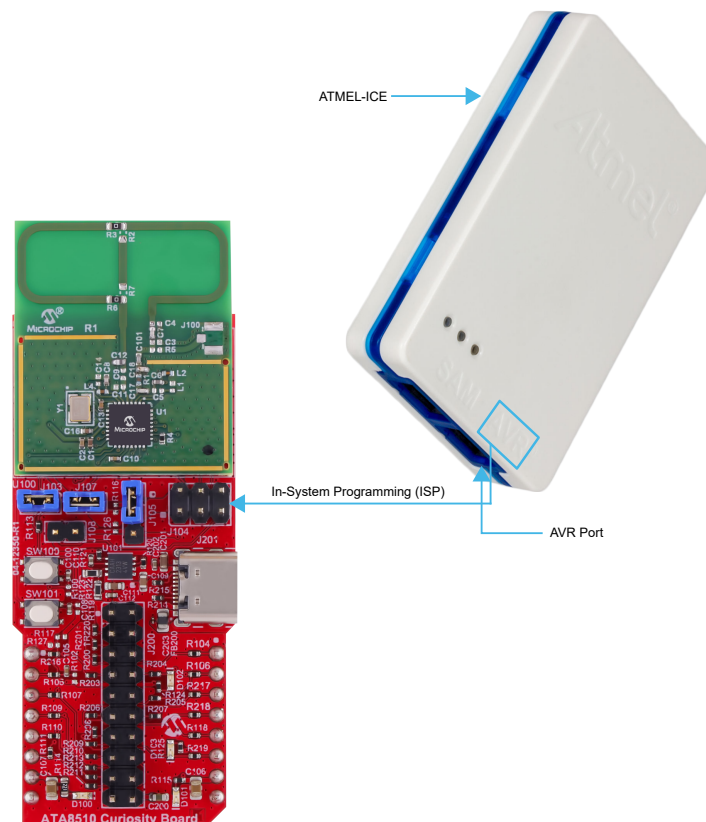
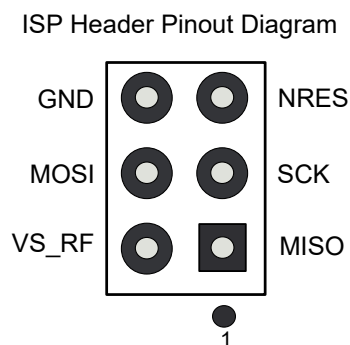

Figure 3-5. ISP Header (J104) Pinout

The following table provides the pin details and descriptions of the ISP header.

Table 3-3. ISP Header Pin Description – J104

Pin Number	Pin on ISP Header	Pin Description of ISP Header	Pin on the ATA8510 RF Board ⁽¹⁾
J104-1	MISO	Host-In Client-Out	PCINT3/MISO/PB3
J104-2	VS_RF	3.3V power supply	VS_RF
J104-3	SCK	Serial Clock	PCINT1/SCK/PB1
J104-4	MOSI	Host-Out Client-In	PCINT2/MOSI/PB2
J104-5	NRES	Reset	NRESET/PCINT8/debugWIRE/PC0
J104-6	GND	Ground	GND

Notes:

- For more details on the ATA8510 SoC pins, refer to the *ATA8510/15 Industrial Data Sheet* ([DS70005505](#)).
- Use ATMEL-ICE for the best programming and debugging experience.

3.3. Mode of Operation

The ATA8510 Curiosity Board supports two modes of operation:

- Standalone mode (default)
- Host mode

3.3.1. Standalone Mode

In Standalone mode, use a pair of ATA8510 Curiosity Boards by configuring one as a receiver and the other as a transmitter.

Power each board individually through a host PC by connecting a Type-C™ cable to connector J201. Refer to [Table 3-2](#) for the required jumper settings in the Standalone mode.

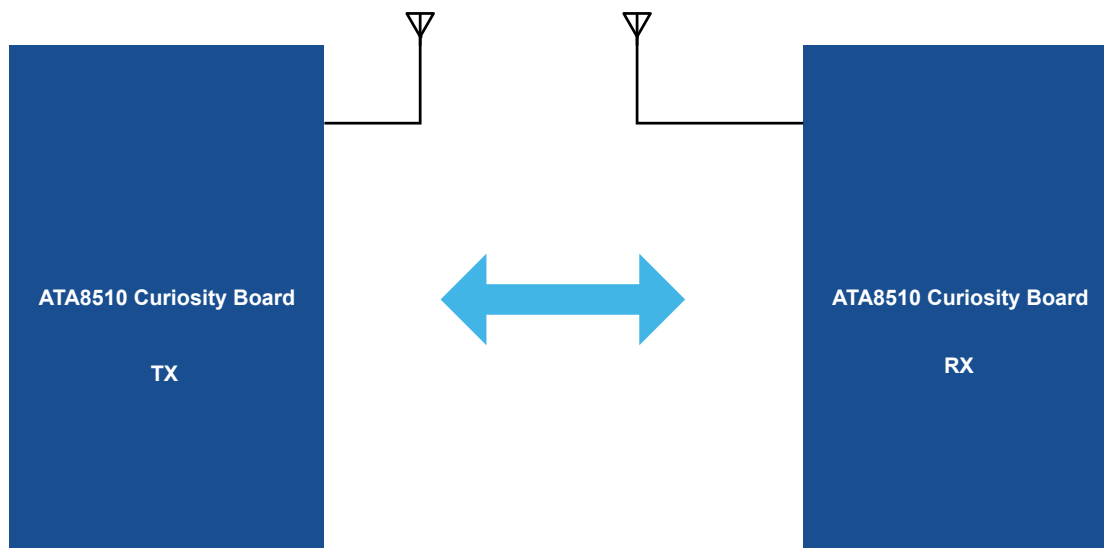
Figure 3-6. RF Communication Setup

For more information on utilizing Standalone mode, refer to the [ATA8510 Curiosity Board Out-of-the-Box Demo](#).

3.3.2. Host Mode

In Host mode, plug the ATA8510 Curiosity Board into a host MCU using the mikroBUS™ header with the control interface.

In this configuration, the host board supplies power to the ATA8510 Curiosity Board, and a USB Type-C™ cable is not required. Refer to [Table 3-2](#) for the jumper settings to use with the host board.

The ATA8510 Curiosity Board communicates with the host board over the SPI via the mikroBUS socket. Refer to the following table for the pinouts on the ATA8510 Curiosity Board mikroBUS interface.

CAUTION

- In Host mode, ensure that the USB Type-C cable is disconnected.
 - All ATA8510 Curiosity Boards have to be programmed with ATMEL-ICE in Standalone mode before use for Host mode with a host board.
-

Figure 3-7. Interface with Host

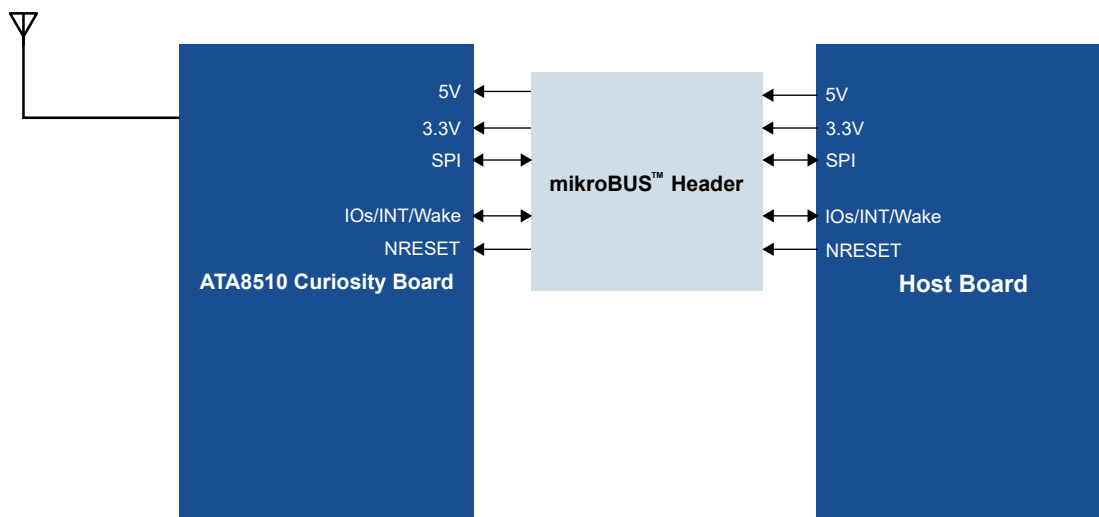

Figure 3-8. mikroBUS™ Pinout Diagram

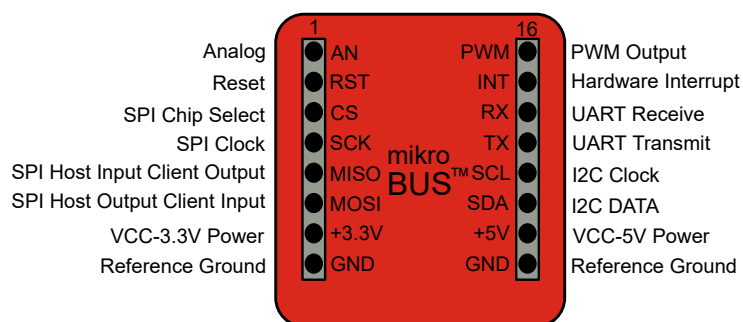

Table 3-4. mikroBUS™ Header Pin Description – J101, J102

Pin Number	Pin on mikroBUS™ Socket	Pin Description of mikroBUS™ Socket	Pin on the ATA8510 RF Board ⁽¹⁾
J101-1	AN	Analog input	PWRON/PCINT4/LED1/PB4
J101-2	RST	Reset	NRESET/PCINT8/debugWIRE/PC0
J101-3	\overline{CS}	SPI Chip Select (CS)	PCINT5/INT1/NSS/PB5
J101-4	SCK	SPI clock	PCINT1/SCK/PB1
J101-5	MISO	SPI Host Input Client Output	PCINT3/MISO/PB3
J101-6	MOSI	SPI Host Input Client Input	PCINT2/MOSI/PB2
J101-7	+3.3V	3.3V power	NC
J101-8	GND	Ground	GND
J102-8	GND	Ground	GND
J102-7	+5V	5V power	NC
J102-6	SDA	I ² C data	NPWRON5/PCINT13/TRPB/TMDO_CLK/PC5
J102-5	SCL	I ² C clock	PCINT0/CLK_OUT/PB0
J102-4	RX	UART receive	NPWRON3/PCINT11/TMDO/TxD/PC3
J102-3	TX	UART transmit	NPWRON4/PCINT12/INT0/TMDI/RxD/PC4

Table 3-4. mikroBUS™ Header Pin Description – J101, J102 (continued)

Pin Number	Pin on mikroBUS™ Socket	Pin Description of mikroBUS™ Socket	Pin on the ATA8510 RF Board ⁽¹⁾
J102-2	INT	Hardware interrupt	PCINT6/EVENT/PB6
J102-1	PWM	PWM output	NPWRON1/PCINT9/EXT_CLK/PC1

Notes:

- For more details on the ATA8510 pins, refer to the *ATA8510/15 Industrial Data Sheet* ([DS70005505](#)).
- These are alternate function pins that can be configured for any of the supported peripheral functions based on the end user application.

3.4. USB Connectivity

The ATA8510 SoC does not have any USB peripheral. The USB Type-C™ connector provided on ATA8510 Curiosity Board is solely to be used for powering the board.

Note: USB Type-A to Type-C USB cable is not available in the ATA8510 Curiosity Board Kit.

3.5. Switches

The following switches are available on the ATA8510 Curiosity Board:

- User-configurable switch ([SW101](#))
- Reset switch ([SW100](#)) connected with NRESET signal of the ATA8510 RF Board

By default, the level of the user-configurable switch is supposedly pulled high (VS_RF), and after pressing the switch, it drives the I/O line to low (GND).

Table 3-5. Description of Switches

Switch Name	Description	Pin on ATA8510 RF Board
SW101	User configurable switch (SW101)	NPWRON1/PCINT9/EXT_CLK/PC1
SW100	Reset switch (SW100)	NRESET/PCINT8/debugWIRE/PC0

3.6. LEDs

The on-board LEDs are categorized into two types:

- Power LEDs
 - 5V Green ([D100](#))
 - 3.3V Green ([D101](#))
- User-Configurable LEDs
 - Red LED ([D102](#))
 - Green LED ([D103](#))

The following table provides details about the list of LEDs that the user can turn ON or OFF while using the connected GPIO pins:

Table 3-6. LEDs Description

Function	Description	Pin on the ATA8510 RF Board
Red LED (D102)	Remappable peripheral/PORTB digital I/O	PB7
Green LED (D103)	Remappable peripheral/PORTC digital I/O	PC5

3.7. 20-Pin Header (J200)

The ATA8510 Curiosity Board features a 20-pin header ([J200](#)) that provides access to pins on the ATA8510 RF Board. The pinouts of the 20-pin header are compatible with the SAM C21 XPRO header,

allowing connection of J200 on the ATA8510 Curiosity Board to the SAM C21 XPRO header via an IDC cable. The following table lists the details of the 20-pin header.

Figure 3-9. 20-Pin Header (J200) Pinout

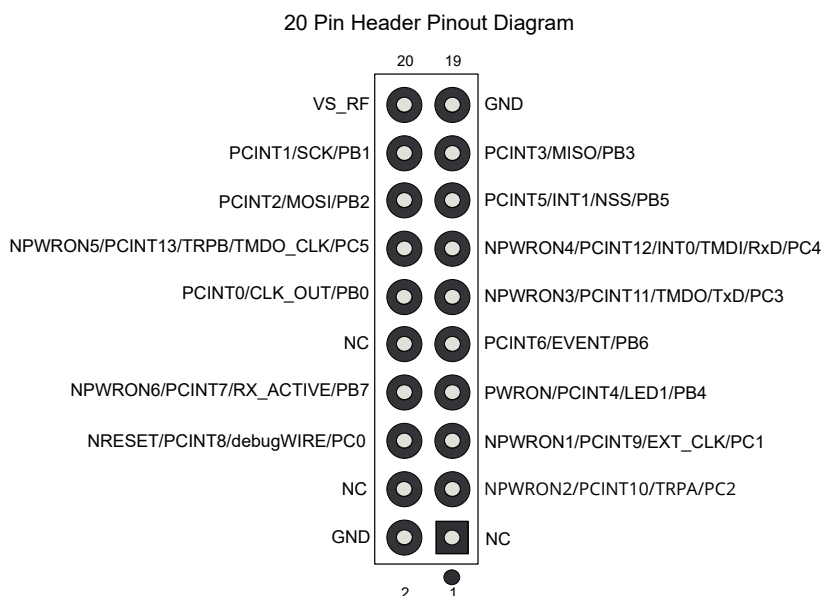

Table 3-7. 20-Pin Header Pin Description – J200

Pin Number	Pin on 20-pin Header	Pin Description of 20-pin Header	Pin on ATA8510 RF Board ^{(1),(2)}
J200-1	NC	Not connected	NC
J200-2	GND	Ground	GND
J200-3	NPWRON2/PCINT10/TRPA/PC2	Remappable peripheral/PORTC digital I/O	NPWRON2/PCINT10/TRPA/PC2
J200-4	NC	Not connected	NC
J200-5	NPWRON1/PCINT9/EXT_CLK/PC1	Remappable peripheral/PORTC digital I/O	NPWRON1/PCINT9/EXT_CLK/PC1
J200-6	NRESET/PCINT8/debugWIRE/PC0	Reset	NRESET/PCINT8/debugWIRE/PC0
J200-7	PWRON/PCINT4/LED1/PB4	Remappable peripheral/PORTB digital I/O	PWRON/PCINT4/LED1/PB4
J200-8	NPWRON6/PCINT7/RX_ACTIVE/PB7	Remappable peripheral/PORTB digital I/O	NPWRON6/PCINT7/RX_ACTIVE/PB7
J200-9	PCINT6/EVENT/PB6	Remappable peripheral/PORTB digital I/O	PCINT6/EVENT/PB6
J200-10	NC	Not connected	NC
J200-11	NPWRON3/PCINT11/TMDO/TxD/PC3	Remappable peripheral/PORTC digital I/O	NPWRON3/PCINT11/TMDO/TxD/PC3
J200-12	PCINT0/CLK_OUT/PB0	Remappable peripheral/PORTB digital I/O	PCINT0/CLK_OUT/PB0

Table 3-7. 20-Pin Header Pin Description – J200 (continued)

Pin Number	Pin on 20-pin Header	Pin Description of 20-pin Header	Pin on ATA8510 RF Board ^{(1),(2)}
J200-13	NPWRON4/PCINT12/INT0/TMDI/RxD/PC4	Remappable peripheral/PORTC digital I/O	NPWRON4/PCINT12/INT0/TMDI/RxD/PC4
J200-14	NPWRON5/PCINT13/TRPB/TMDO_CLK/PC5	Remappable peripheral/PORTC digital I/O	NPWRON5/PCINT13/TRPB/TMDO_CLK/PC5
J200-15	PCINT5/INT1/NSS/PB5	Client select for SPI	PCINT5/INT1/NSS/PB5
J200-16	PCINT2/MOSI/PB2	Host-Out, Client-In line of SPI	PCINT2/MOSI/PB2
J200-17	PCINT3/MISO/PB3	Host-In, Client-Out line of SPI	PCINT3/MISO/PB3
J200-18	PCINT1/SCK/PB1	Clock for SPI	PCINT1/SCK/PB1
J200-19	GND	Ground	GND
J200-20	VS_RF	Power from extension board	VS

Notes:

1. These are alternate function pins that can be configured for any of the supported peripheral functions based on the end user application.
2. For more details on the ATA8510 pins, refer to the *ATA8510/15 Industrial Data Sheet* ([DS70005505](#)).

4. **ATA8510 Curiosity Board Out-of-the-Box Demo**

The ATA8510 Curiosity Board Out-of-the-Box (OOB) demo demonstrates its standalone operation and basic RF transmission and RF reception capabilities.

For more information on the PC Companion mode OOB demo, go to github.com/MicrochipTech/ATA8510_Curiosity_OOB.

For more details on applications demo and harmony code examples, go to [wireless_apps_ata851x](https://www.microchip.com/wireless_apps_ata851x).

5. Appendix A: Reference Circuit

5.1. ATA8510 Curiosity Board Reference Schematics

Figure 5-1. ATA8510 RF Board

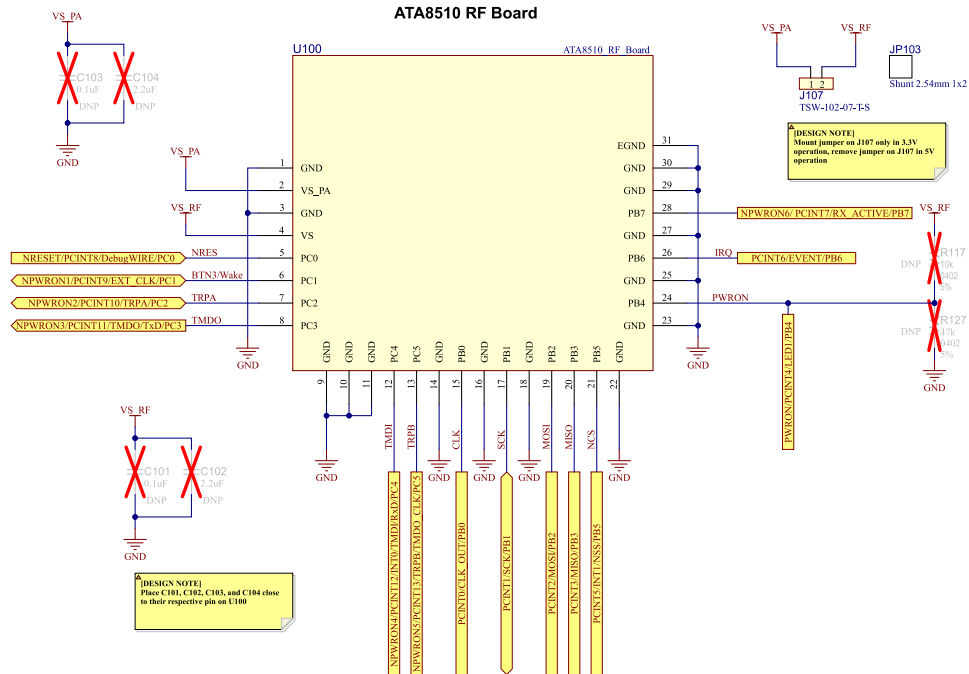

Figure 5-2. Power Indication LEDs

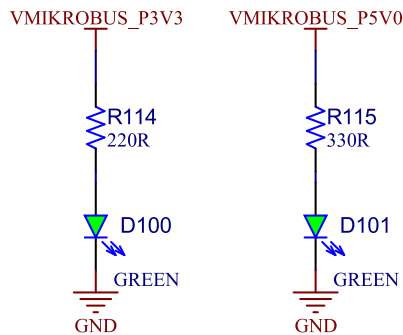

Figure 5-3. Power Supply Selection and Current Measurement

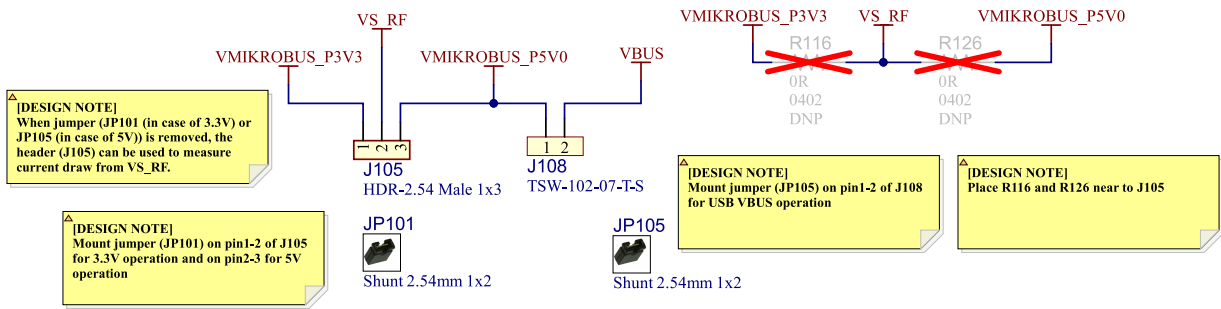

Figure 5-4. Reset Button

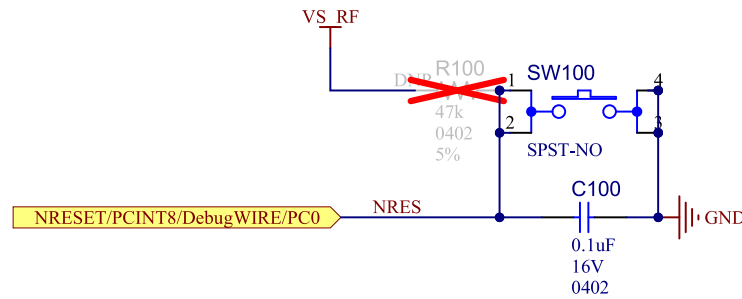

Figure 5-5. Switch Button on PC1

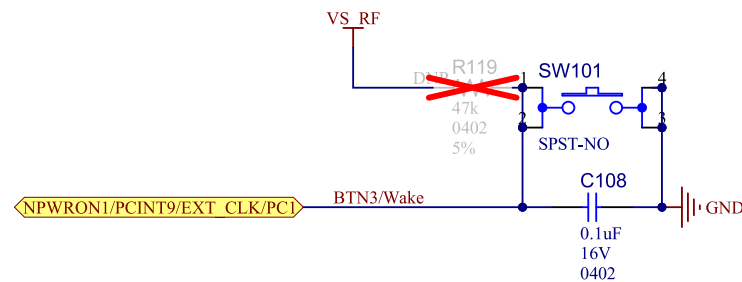

Figure 5-6. 3.3V Regulator

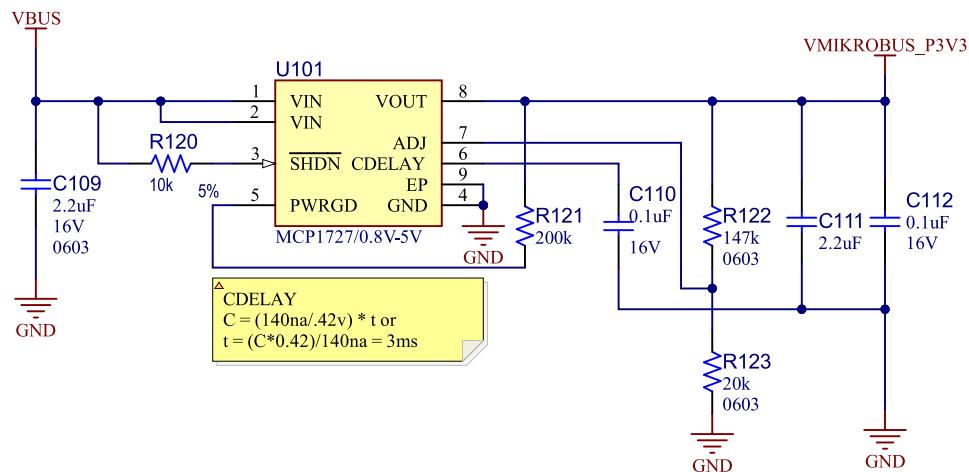

Figure 5-7. User LEDs

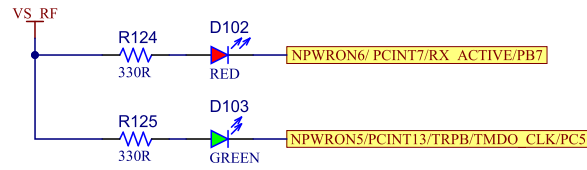

Figure 5-8. 20-Pin Header

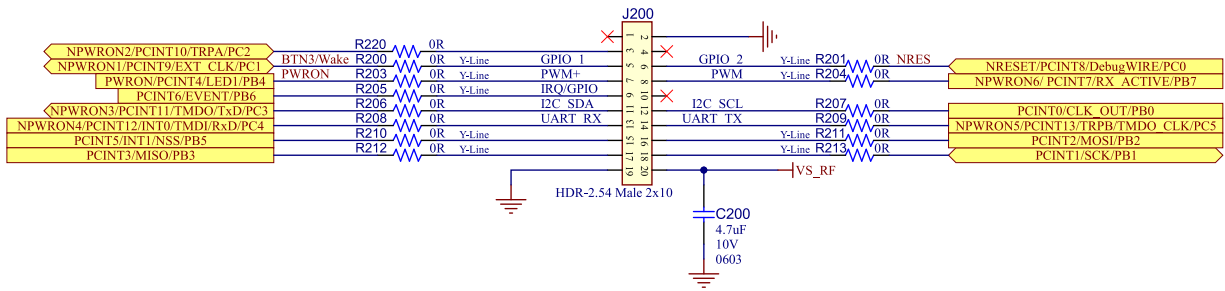

Figure 5-9. ISP Header

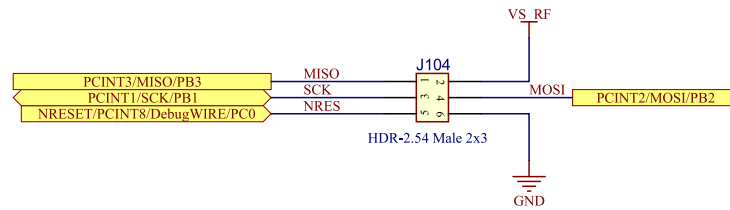

Figure 5-10. mikroBUS™ Header

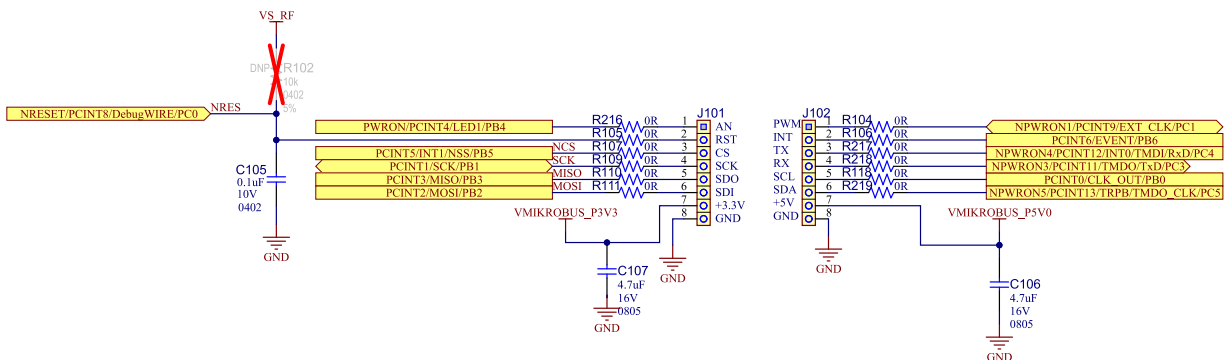

Figure 5-11. USB Type-C™

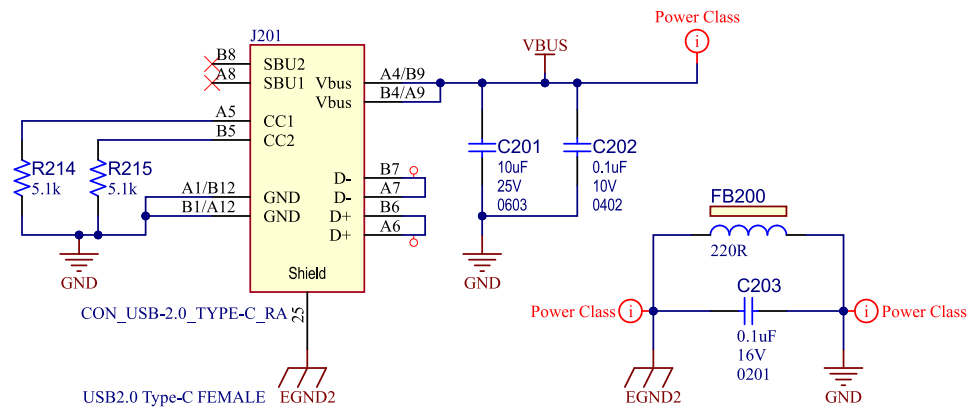
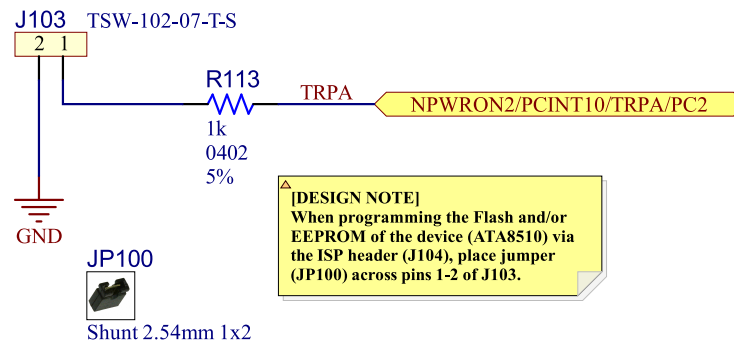

Figure 5-12. Enable/Disable Programming



5.2. ATA8510 Curiosity Board Bill of Materials

For the Bill of Materials (BOM) of the ATA8510 Curiosity Board, go to the [EV82M22A](#) product web page.

6. Appendix-B: PCB Antenna and RF Considerations

The overall RF performance of the system is significantly influenced by product design, environment, and application. The product designer must ensure system-level shielding (if required) and verify the performance of product features and applications. For optimal wireless performance, consider the following guidelines:

- The ATA8510 device must be positioned in a noise-free RF environment and must be kept far away from high-frequency clock signals and any other sources of RF energy.
- The antenna must not be shielded by any metal objects.
- The power supply must be clean and noise-free.
- The ATA8510 Curiosity Board does not include RF shielding on the top of the board by default.

For the ATA8510 Curiosity Board, the PCB antenna is fabricated on the top layer and covered in a solder mask. The layers below the antenna do not have copper trace. It is recommended to have the PCB antenna to be on the edge of the host board and have no PCB material below the antenna structure and no copper traces or planes on the host board in that area.

The following table lists the technical specification of the PCB antenna on the ATA8510 Curiosity Board:

Table 6-1. PCB Antenna Specifications

Parameter	Specification
Operating Frequency	430-435 MHz
Peak Gain	-1.8 dBi
Efficiency (average)	22.5%

Antenna radiation patterns at 433 MHz:

Figure 6-1. Phi = 0 Degree Antenna Radiation Pattern

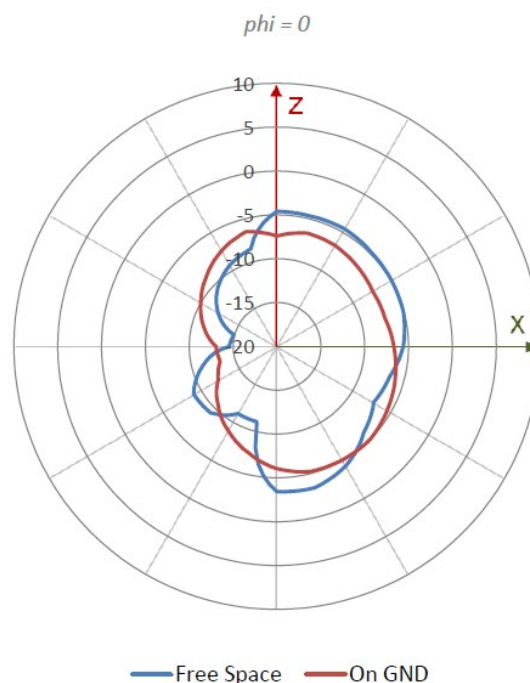
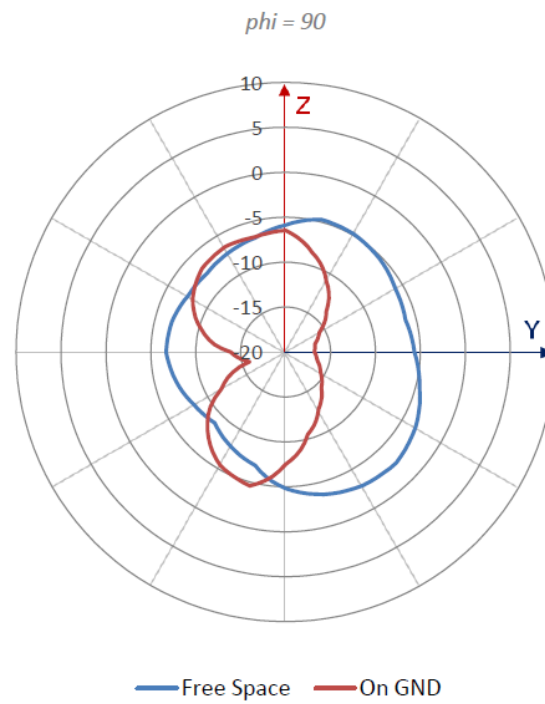
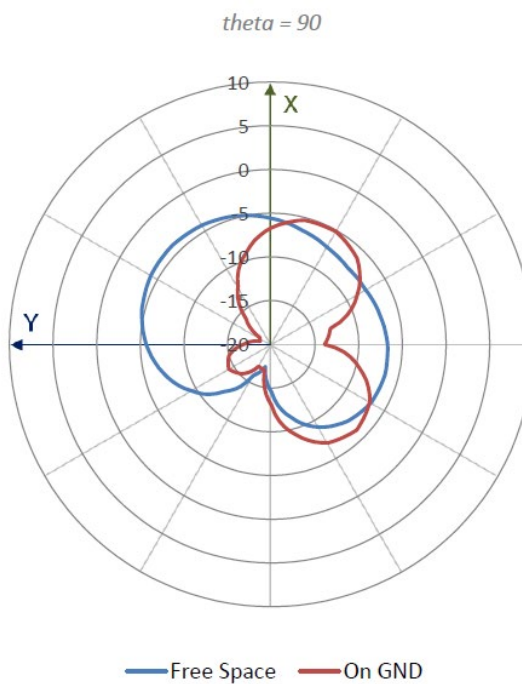

Figure 6-2. Phi = 90 Degree Antenna Radiation Pattern**Figure 6-3.** Theta = 90 Degree Antenna Radiation Pattern

6.1. RF Performance with Host Board

When using the ATA8510 Curiosity Board with a host board, follow the guidelines listed in [Appendix-B: PCB Antenna and RF Considerations](#). This includes ensuring that no cables run beneath the PCB antenna and no high-frequency components are placed on the host board under the antenna area.

When evaluating the ATA8510 Curiosity Board with the WBZ451HPE Curiosity Board or similar host boards, use a 90-degree angle elbow Type-C™ cable on the host board. This helps prevent degradation in RF performance.

Figure 6-4. Impact on RF Performance When Using Different Types of USB Type-C™ Cables

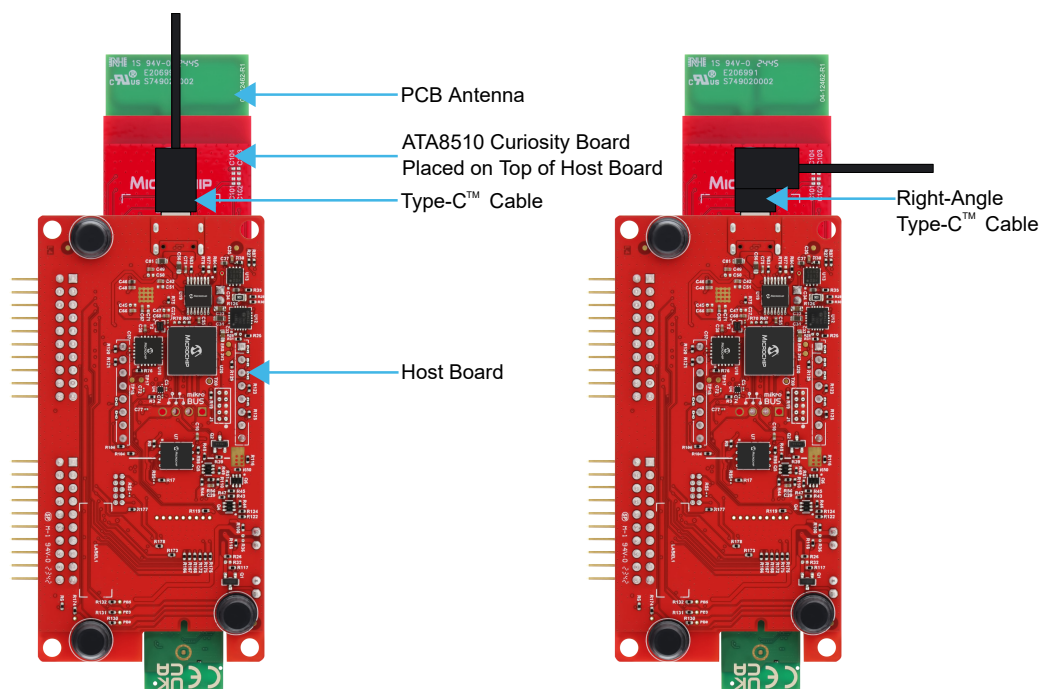

Figure A: Degraded RF Performance

Figure B: Optimal RF Performance

In Figure A, the USB Type-C cable on the host board runs directly beneath the PCB antenna of the ATA8510 Curiosity Board. This might degrade the RF performance.

In Figure B, a 90-degree angle elbow Type-C cable is used, which does not run under the PCB antenna of the ATA8510 Curiosity Board. This setup avoids interference with RF performance and is the recommended approach.

7. Appendix C: Regulatory Approval

This equipment (ATA8510 Curiosity Board/EV82M22A) is an evaluation kit and not a finished product. It is intended for laboratory evaluation purposes only. It is not directly marketed or sold to the general public through retail; it is only sold through authorized distributors or through Microchip. Using this requires a significant engineering expertise towards understanding of the tools and relevant technology, which can be expected only from a person who is professionally trained in the technology.

Regulatory compliance settings have to follow the ATA8510 RF Board certifications. The following regulatory notices are to cover the requirements under the regulatory approval.

7.1. United States

The ATA8510 Curiosity Board (EV82M22A) contains the ATA8510 RF Board, which has received Federal Communications Commission (FCC) CFR47 Telecommunications, Part 15 Subpart C "Intentional Radiators" single-modular approval in accordance with Part 15.212 Modular Transmitter approval.

Contains FCC ID: 2ADHKATA8510M

This device complies with Part 15 of the FCC Rules. Operation is subject to the following two conditions: (1) this device may not cause harmful interference, and (2) this device must accept any interference received, including interference that may cause undesired operation.



Important: FCC Radiation Exposure Statement

This equipment complies with FCC radiation exposure limits set forth for uncontrolled environment. The antenna(s) used for this transmitter must be installed to provide a separation distance of at least 8 cm from all persons and must not be co-located or operating in conjunction with any other antenna or transmitter. This transmitter is restricted for use with the specific antenna(s) tested in this application for certification.



Any changes or modifications not expressly approved by the party responsible for compliance could void the user's authority to operate this equipment.

Note: This equipment has been tested and found to comply with the limits for a Class B digital device, pursuant to part 15 of the FCC rules. These limits are designed to provide reasonable protection against harmful interference in a residential installation. This equipment generates, uses and can radiate radio frequency energy and, if not installed and used in accordance with the instructions, may cause harmful interference to radio communications. However, there is no guarantee that interference will not occur in a particular installation. If this equipment does cause harmful interference to radio or television reception, which can be determined by turning the equipment off and on, the user is encouraged to try to correct the interference by one or more of the following measures:

- Reorient or relocate the receiving antenna.
- Increase the separation between the equipment and receiver.
- Connect the equipment into an outlet on a circuit different from that to which the receiver is connected.
- Consult the dealer or an experienced radio/TV technician for help.

7.2. Canada

The ATA8510 Curiosity Board (EV82M22A) contains the ATA8510 RF Board, which has been certified for use in Canada under Innovation, Science and Economic Development Canada (ISED, formerly Industry Canada) Radio Standards Procedure (RSP) RSP-100, Radio Standards Specification (RSS) RSS-Gen and RSS-247.

Contains IC: 20266-ATA8510M

This device contains license-exempt transmitter(s)/receiver(s) that comply with Innovation, Science and Economic Development Canada's license-exempt RSS(s). Operation is subject to the following two conditions:

1. This device may not cause interference;
2. This device must accept any interference, including interference that may cause undesired operation of the device.

L'émetteur/récepteur exempt de licence contenu dans le présent appareil est conforme aux CNR d'Innovation, Sciences et Développement économique Canada applicables aux appareils radio exempts de licence. L'exploitation est autorisée aux deux conditions suivantes:

1. L'appareil ne doit pas produire de brouillage;
2. L'appareil doit accepter tout brouillage radioélectrique subi, même si le brouillage est susceptible d'en compromettre le fonctionnement.



This equipment complies with radio frequency exposure limits set forth by Innovation, Science and Economic Development Canada for an uncontrolled environment. This equipment should be installed and operated with a minimum distance of 20 cm between the device and the user or bystanders.

Cet équipement est conforme aux limites d'exposition aux radiofréquences définies par d'Innovation, Sciences et Développement économique Canada pour un environnement non contrôlé. Cet équipement doit être installé et utilisé avec un minimum de 20 cm de distance entre le dispositif et l'utilisateur ou des tiers.

7.3. Europe

This equipment (EV82M22A) has been assessed under the Radio Equipment Directive (RED) for use in European Union countries. The product does not exceed the specified power ratings, antenna specifications and/or installation requirements as specified in the user manual. A Declaration of Conformity is issued for each of these standards and kept on file as described in Radio Equipment Directive (RED).

Simplified EU Declaration of Conformity

Hereby, Microchip Technology Inc. declares that the radio equipment type [EV82M22A] is in compliance with Directive 2014/53/EU.

The full text of the EU declaration of conformity is available at [EV82M22A](#) (See *Conformity Documents*).

8. Document Revision History

The revision history describes the changes that were implemented in the document. The changes are listed by revision, starting with the most current publication.

Table 8-1. Document Revision History

Revision	Date	Section	Description
A	07/2025	Document	Initial revision

Microchip Information

Trademarks

The “Microchip” name and logo, the “M” logo, and other names, logos, and brands are registered and unregistered trademarks of Microchip Technology Incorporated or its affiliates and/or subsidiaries in the United States and/or other countries (“Microchip Trademarks”). Information regarding Microchip Trademarks can be found at <https://www.microchip.com/en-us/about/legal-information/microchip-trademarks>.

ISBN: 979-8-3371-1542-9

Legal Notice

This publication and the information herein may be used only with Microchip products, including to design, test, and integrate Microchip products with your application. Use of this information in any other manner violates these terms. Information regarding device applications is provided only for your convenience and may be superseded by updates. It is your responsibility to ensure that your application meets with your specifications. Contact your local Microchip sales office for additional support or, obtain additional support at www.microchip.com/en-us/support/design-help/client-support-services.

THIS INFORMATION IS PROVIDED BY MICROCHIP “AS IS”. MICROCHIP MAKES NO REPRESENTATIONS OR WARRANTIES OF ANY KIND WHETHER EXPRESS OR IMPLIED, WRITTEN OR ORAL, STATUTORY OR OTHERWISE, RELATED TO THE INFORMATION INCLUDING BUT NOT LIMITED TO ANY IMPLIED WARRANTIES OF NON-INFRINGEMENT, MERCHANTABILITY, AND FITNESS FOR A PARTICULAR PURPOSE, OR WARRANTIES RELATED TO ITS CONDITION, QUALITY, OR PERFORMANCE.

IN NO EVENT WILL MICROCHIP BE LIABLE FOR ANY INDIRECT, SPECIAL, PUNITIVE, INCIDENTAL, OR CONSEQUENTIAL LOSS, DAMAGE, COST, OR EXPENSE OF ANY KIND WHATSOEVER RELATED TO THE INFORMATION OR ITS USE, HOWEVER CAUSED, EVEN IF MICROCHIP HAS BEEN ADVISED OF THE POSSIBILITY OR THE DAMAGES ARE FORESEEABLE. TO THE FULLEST EXTENT ALLOWED BY LAW, MICROCHIP’S TOTAL LIABILITY ON ALL CLAIMS IN ANY WAY RELATED TO THE INFORMATION OR ITS USE WILL NOT EXCEED THE AMOUNT OF FEES, IF ANY, THAT YOU HAVE PAID DIRECTLY TO MICROCHIP FOR THE INFORMATION.

Use of Microchip devices in life support and/or safety applications is entirely at the buyer’s risk, and the buyer agrees to defend, indemnify and hold harmless Microchip from any and all damages, claims, suits, or expenses resulting from such use. No licenses are conveyed, implicitly or otherwise, under any Microchip intellectual property rights unless otherwise stated.

Microchip Devices Code Protection Feature

Note the following details of the code protection feature on Microchip products:

- Microchip products meet the specifications contained in their particular Microchip Data Sheet.
- Microchip believes that its family of products is secure when used in the intended manner, within operating specifications, and under normal conditions.
- Microchip values and aggressively protects its intellectual property rights. Attempts to breach the code protection features of Microchip products are strictly prohibited and may violate the Digital Millennium Copyright Act.
- Neither Microchip nor any other semiconductor manufacturer can guarantee the security of its code. Code protection does not mean that we are guaranteeing the product is “unbreakable”. Code protection is constantly evolving. Microchip is committed to continuously improving the code protection features of our products.

Product Page Links

[ATA8510](#)