

# Wio-LR1121 Module

LoRa® Wireless Module LR1121

Datasheet

V1.0

## Content

|  |   |
|--|---|
| Content.....   | 1 |
| 1 Introduction.....  | 1 |
| 2 Description.....   | 2 |
| 3 Pin Definition .....                                       | 3 |
| 4 Electrical Characteristics.....                            | 4 |
| 4.1 Absolute Maximum Rating.....                             | 4 |
| 4.2 Normal Working Conditions.....                           | 4 |
| 4.3 Digital I/O Characteristics.....                         | 4 |
| 4.4 Module Specifications.....                               | 4 |
| 5 Application Information.....                               | 6 |
| 5.1 Package Information.....                                 | 6 |
| 5.2 External Interface of the Module .....                   | 6 |
| 5.3 Reference Design Based on LR1121 Module.....             | 6 |
| 6 Application Information.....                               | 7 |
| 6.1 LoRaWAN® application.....                                | 7 |
| 6.2 Design LoRaWAN® wireless sensor based on Wio-LR1121..... | 7 |
| 7 Reflow Soldering Parameters.....                           | 8 |
| 8 Ordering Information.....                                  | 9 |
| 9 Reversion.....   | 9 |

# 1 Introduction



Wio-LR1121 is a multi-band LoRa® connectivity module designed for Internet of Things (IoT) LoRaWAN applications. It supports sub-GHz, 2.4GHz ISM, and 2.1GHz satellite S-band communications. The module features a compact size and an ultra-low power design, integrating a TCXO (temperature-compensated crystal oscillator) and an RF switch, is suitable for global use in smart homes, agricultural sensors, building automation, smart cities, asset tracking, retail store sensors, smart metering, and environmental monitoring.

- **RF Interface:**
  - ✓ Wio-LR1121 (With IPEX4 @1.5mm)
  - ✓ Wio-LR1121-N (With Pin)
- **Supports multiple frequency bands:**
  - ✓ Sub-GHz: 20.33dBm @ 863-928MHz
  - ✓ 2.4GHz: 11.23dBm @ 2.4-2.5GHz
- **Low Power Consumption:**
  - ✓ as low as 1.35uA sleep current
  - ✓ Sub-GHz: 20.33dBm@124.5mA/3.3V
  - ✓ 2.4G: 11.23dBm@30.72mA/3.3V
- **SPI Interface**
- **Certifications:** CE,FCC
- **Low Cost and High performance**
- **Small Size:** 17\*12\*2.6mm @24Pins SMT
- **Receive Sensitivity:**
  - SubG: SF7,BW=125K,RXboost=1: -126dBm
  - SubG: SF7,BW=125K,RXboost=0: -124dBm
  - SubG: SF12,BW=125K,RXboost=1: -140dBm
  - SubG: SF12,BW=125K,RXboost=0: -138dBm
  - 2.4G: SF7,BW=406K,RXboost=1: -115.5dB

| Part Number  | TX Power   |
|--------------|--|
| Wio-LR1121   | 20.33dBm @ 863-928MHz / 11.23dBm @ 2.4-2.5GHz with IPEX4         |
| Wio-LR1121-N | 20.33dBm @ 863-928MHz / 11.23dBm @ 2.4-2.5GHz with SMT (No IPEX) |

## 2 Description

The LR1121 module, based on the Semtech LR1121, is designed for IoT applications, supporting (G)FSK and LoRa® modulations with a 7.8 to 500 kHz bandwidth in LoRa® mode. It features an SPI interface for MCU communication, a DC-DC power scheme, and a high-precision TCXO for RF reference frequency, with VTCXO as the TCXO voltage supply. Available in two variants—Wio-LR1121 with IPEX4 interface and Wio-LR1121-N with SMT Pin—both support 20.33dBm output power in the 862-930MHz and 11.23dBm output power in the 2.4-2.5GHz.

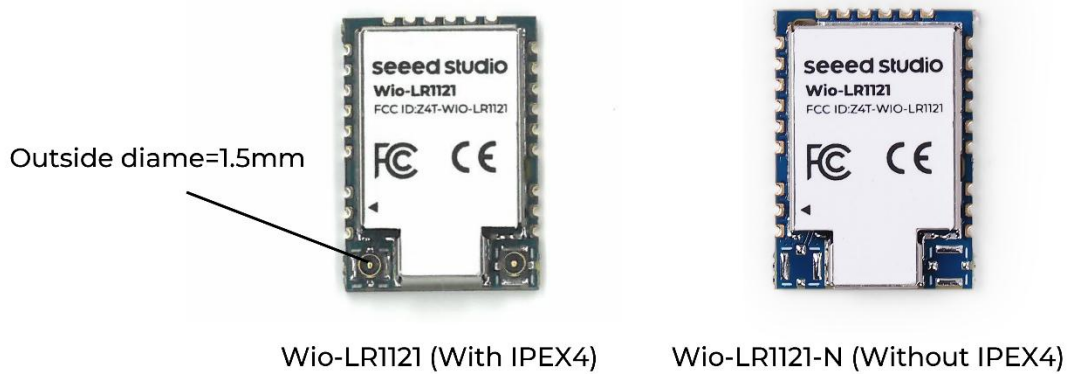

Figure 1 Wio-LR1121 and Wio-LR1121-N

### Schematic Diagram:

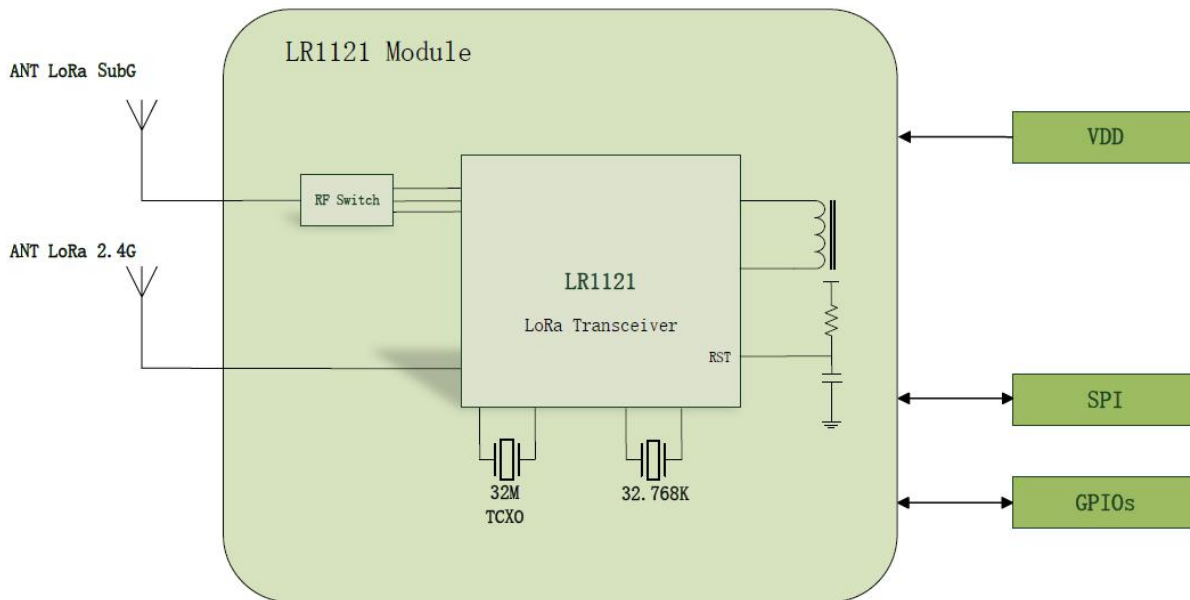

Figure 2 Wio-LR1121 Schematic Diagram

### 3 Pin Definition

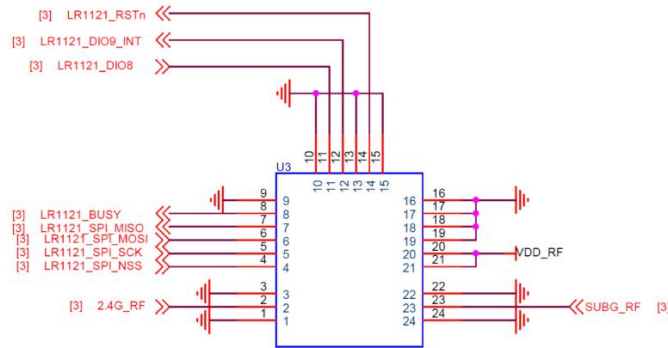

Figure 3 Wio-LR1121 Pinout

| Number | Name    | Type  | Description                        |
|--------|---------|-------|------------------------------------|
| 1      | GND     | GND   | Ground                             |
| 2      | 2.4G RF | RF    | 2.4G and Sband RF channel          |
| 3      | GND     | GND   | Ground                             |
| 4      | LR_NSS  | I/O   | SPI NSS                            |
| 5      | LR_SCK  | I/O   | SPI SCK                            |
| 6      | LR_MOSI | I/O   | SPI MOSI                           |
| 7      | LR_MISO | I/O   | SPI MISO                           |
| 8      | LR_BUSY | I/O   | LR1121: DIO0/ BUSY                 |
| 9      | GND     | GND   | Ground                             |
| 10     | GND     | GND   | Ground                             |
| 11     | DIO8    | I/O   | Multi-purpose digital I/O          |
| 12     | DIO9    | I/O   | Multi-purpose digital I/O ,INT Pin |
| 13     | GND     | GND   | Ground                             |
| 14     | RST     | I/O   | Ground                             |
| 15     | GND     | GND   | Ground                             |
| 16     | GND     | GND   | Ground                             |
| 17     | GND     | GND   | Ground                             |
| 18     | GND     | GND   | Ground                             |
| 19     | GND     | GND   | Ground                             |
| 20     | VDD_RF  | Power | Supply voltage for LoRa®           |
| 21     | VDD_RF  | Power | Supply voltage for LoRa®           |
| 22     | GND     | GND   | Ground                             |
| 23     | SUBG_RF | RF    | SUBG RF channel                    |
| 24     | GND     | GND   | Ground                             |

## 4 Electrical Characteristics

Reaching or exceeding the maximum ratings in the table below can cause equipment damage.

### 4.1 Absolute Maximum Rating

| Item | Description          | min  | max  | unit |
|------|----------------------|------|------|------|
| VDD  | LoRa® supply voltage | -0.3 | +3.6 | V    |
| TA   | Ambient temperature  | -40  | +85  | °C   |

### 4.2 Normal Working Conditions

| Item | Description          | min  | max  | unit |
|------|----------------------|------|------|------|
| VDD  | LoRa® supply voltage | +1.8 | +3.6 | V    |

### 4.3 Digital I/O Characteristics

| Item | Description         | min     | max     | unit |
|------|---------------------|---------|---------|------|
| VIH  | Input high voltage  | 0.7*VDD | VDD+0.3 | V    |
| VIL  | Input low voltage   | -0.3    | 0.3*VDD | V    |
| VOH  | Output high voltage | 0.9*VDD | VDD     | V    |
| VOL  | Output low voltage  | 0       | 0.1*VDD | dBm  |

### 4.4 Module Specifications

| ITEMs                      | Parameter                       | Specifications  | Unit |
|----------------------------|---------------------------------|---|------|
| Structure                  | Size                            | 17(L) X 12(W) X 2.6(H)                                  | mm   |
|                            | Package                         | 24 pin Module   |      |
| Electrical Characteristics | Power supply                    | 3.3V typical  | V    |
|                            | Sleep current                   | 1.35  | uA   |
|                            | Operation current (Transmitter) | 124.5mA @ LoRa® 915 TX 22dBm                            | mA   |
|                            |                                 | 31mA@ LoRa® 868 TX 14dBm<br>30.7mA@ LoRa® 2.4G TX 13dBm |      |
|                            | Operation current (Receiver)    | 7.8mA@ LoRa® SF12 125kHz sub-GHz                        | mA   |
|                            |                                 | 6.7mA@LoRa® SF12 125kHz 2.4GHz/S-band                   |      |
| Output power               | 20.4dBm max @LoRa®              | dBm   |      |
|                            | 11dBm max @ 2.4G                |   |      |

|                                 |                            |   |     |
|---------------------------------|----------------------------|---|-----|
|                                 | Sensitivity RxBoost<br>ON  | -126dBm @SubG,BW=125KHz, SF = 7<br>-140dBm @SubG, BW=125KHz, SF = 12<br>-118dBm @2.4G,BW=125KHz, SF = 7<br>-132.5dBm @2.4G ,BW=125KHz, SF = 7 | dBm |
|                                 | Sensitivity RxBoost<br>OFF | -124dBm @SubG,BW=125KHz, SF = 7<br>-138dBm @SubG, BW=125KHz, SF = 12  | dBm |
| <b>Peripheral<br/>Interface</b> | SPI/GPIOS                  |   |     |

## 5 Application Information

### 5.1 Package Information

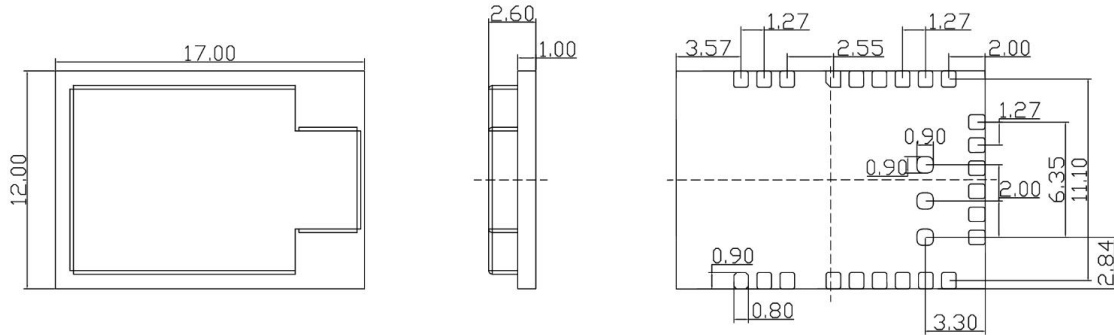

Figure 4 Package Outline Drawing

Library file: [ALLEGRO Library](#)

### 5.2 External Interface of the Module

- DIO9 is the generic IRQ line
- The output impedance of the RF is 50 Ω and compatible with IPEX and SMT-Pin.
- Busy is used as a busy signal indicating that the module is ready for new command only if this signal is low.

### 5.3 Reference Design Based on LR1121 Module

The following is a typical reference design using the LR1121 module. Just connect the module to the host MCU according to the reference design.

Antenna design considerations: The antenna interfaces are designed with a 50Ω impedance. It is recommended that users reserve a π-type matching network for each antenna output.

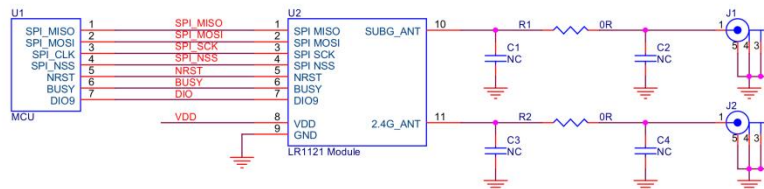

Figure 5 Reference design based on Wio-LR1121

## 6 Application Information

### 6.1 LoRaWAN® application

The LoRaWAN® network uses a star topology, where gateways serve as relays between end nodes and the network server. Gateways are connected to the network server via standard IP links, while end devices communicate with one or more gateways using LoRa® or FSK modulation. Communication is bidirectional, although it is predominantly uplink from the nodes to the network server.

Communication between nodes and gateways occurs on different frequencies and data rates, where the choice of data rate balances power consumption and communication range. These different data rates do not interfere with each other. Depending on the spreading factor and bandwidth used, LoRa® data rates range from 300 bps to 50 kbps. To maximize battery life and network capacity, the network server uses Adaptive Data Rate (ADR) to manage each node's transmission rate and output power.

End devices can transmit at any time, using any available data rate, and on a randomly selected channel, provided the following conditions are met:

- The channel selected is pseudo-random, which enhances the system's resistance to interference;
- The maximum transmission time (dwell time) and duty cycle are constrained by the frequency band in use and local regulatory requirements.

### 6.2 Design LoRaWAN® wireless sensor based on Wio-LR1121

The Wio-LR1121 is a pure RF module that only requires a simple MCU as the main controller. Through an SPI interface, the MCU can control the Wio-LR1121 module to easily implement the LoRaWAN® protocol. This setup enables customers to quickly develop and bring sensor products to the LoRaWAN® market.

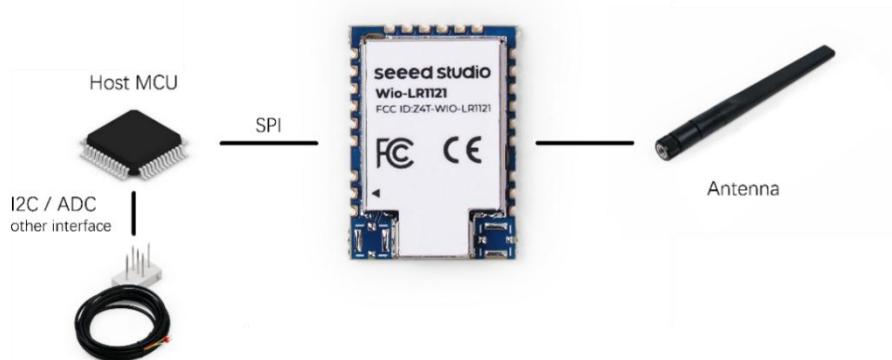

Figure 6 Design of LoRaWAN® wireless sensor based on Wio-LR1121 module

## 7 Reflow Soldering Parameters

The design of the LR1121 module facilitates production, enabling easy soldering onto PCB boards using reflow soldering technology. A key requirement is selecting suitable solder paste that meets the temperature specifications during the reflow process. The LR1121 adheres to the J-STD-020D1 standard for reflow soldering temperature requirements.

Note: It is recommended to subject the module to only one reflow soldering cycle, with the module temperature not exceeding 260°C during the process. The reflow period should not exceed 30 seconds.

| Item  | value | Unit   |
|---|-------|--------|
| Heating rate  | 1~3   | °C/Sec |
| Cooling rate  | 2~4   | °C/Sec |
| Heating rate of preheating zone                                       | 0.5~1 | °C/Sec |
| Preheating zone length MIN  | 70    | Sec    |
| Preheating zone length MAX  | 120   | Sec    |
| Preheating temperature MIN  | 150   | °C     |
| Preheating temperature MAX  | 190   | °C     |
| Residence time of solder paste above the liquefaction temperature MAX | 70    | Sec    |
| Residence time of solder paste above the liquefaction temperature MIN | 50    | Sec    |
| Residence time in the reflux zone                                     | 30    | Sec    |
| Peak temperature residence time MAX                                   | 5     | Sec    |
| Suggested liquefaction zone threshold                                 | 218   | °C     |
| Low point temperature of reflux zone                                  | 240   | °C     |
| High point temperature in the reflux zone                             | 250   | °C     |
| Absolute peak temperature   | 260   | °C     |

## 8 Ordering Information

---

Technical Support: [sensecap@seeed.cc](mailto:sensecap@seeed.cc)

Sales: [iot@seeed.cc](mailto:iot@seeed.cc)

## 9 Reversion

---

V0.1 2025-4-28 First release

V0.2 2025-4-30 revised format

V1.0 2025-7-1 Release