

NTC Thermistors, MegaSurge™ Inrush Current Limiters



FEATURES

- Ability to withstand high steady-state currents to 50 A and up to 1000 J of input energy
- Protect rectifiers and other downstream components from damage caused by sudden current spikes
- Increase safety by eliminating the fire hazard associated with failed relays
- Handle the same amount of energy as power resistors in a smaller package, saving valuable circuit board space
- Provide simple one-component alternatives to using power resistors with timers and relays, reducing costs and greatly simplifying designs
- UL-recognized MegaSurge™ devices are certified for single- and three-phase input voltages up to 480 V_{AC}

DESCRIPTION

These power thermistors are rugged and built to last even in the most demanding high power applications.

These inrush current limiters are also used to regulate the release of battery energy in electric vehicles and in pre-charge circuits for many different types of battery chargers.

APPLICATIONS

- Alternative energy
- Electric vehicles
- Inrush current protection of power supplies, motor controllers, audio amplifiers, battery chargers, frequency generators, plasma cutting tools, MRI machines, and toroidal transformers

QUICK REFERENCE DATA

PART NUMBER	RESISTANCE AT 25 °C (R_{25}) (Ω)	TOLERANCE ON R_{25} VALUE (%)	MAX. STEADY-STATE CURRENT UP TO 65 °C (A)	MAX. RECOMMENDED ENERGY RATING (J)	MAX. VOLTAGE (V _{AC})	MAX. CAPACITANCE AT 120 V _{AC} (μ F)
MS1215102	150	± 20	2	110	265	6900
MS1515004	15	± 25	4.5	155	265	10 500
MS1515004A	15	± 25	4.5	155	265	10 500
MS1530004	30	± 25	4.2	135	265	9300
MS1540004	40	± 25	4.1	135	265	9300
MS1566003	66	± 25	3.5	125	265	8500
MS225R015	5	± 25	15	200	480	13 850
MS2210008	10	± 25	8	200	480	13 850
MS2210008B	10	± 25	8	200	480	13 850
MS2220005	20	± 25	5	180	480	12 000
MS2220005A324	20	± 25	5	180	480	12 000
MS2230005	30	± 20	5	150	480	10 300
MS2250004	50	± 25	4	240	480	16 400
MS2250004B	50	± 25	4	240	480	16 400
MS2275004	75	± 25	4	240	480	16 400
MS2212102	120	± 25	2	220	480	15 000
MS2212103	120	± 25	3	220	480	15 000
MS2212103B	120	± 25	3	220	480	15 000
MS2212104	120	± 25	4	220	480	15 220
MS2212104B	120	± 25	4	220	480	15 220



QUICK REFERENCE DATA						
PART NUMBER	RESISTANCE AT 25 °C (R_{25}) (Ω)	TOLERANCE ON R_{25} VALUE (%)	MAX. STEADY-STATE CURRENT UP TO 65 °C (A)	MAX. RECOMMENDED ENERGY RATING (J)	MAX. VOLTAGE (V_{AC})	MAX. CAPACITANCE AT 120 V_{AC} (μ F)
MS2222103	220	± 25	3	75	480	5100
MS320R536	0.5	± 25	36	250	480	16 000
MS320R540	0.5	± 25	40	250	480	13 500
MS321R030	1	± 25	30	250	480	13 500
MS321R036	1	± 25	36	300	480	20 700
MS322R025	2	± 25	25	300	480	20 700
MS325R020	5	± 20	20	300	480	20 700
MS325R020B	5	± 20	20	300	480	20 700
MS327R015	7	± 20	15	250	480	17 000
MS3210015	10	± 25	15	250	480	19 250
MS3210015B	10	± 25	15	250	480	19 250
MS3215012	15	± 25	12	250	480	17 300
MS3220008	20	± 25	8	250	480	17 300
MS3220008B	20	± 25	8	250	480	17 300
MS3220010	20	± 25	10	250	480	17 000
MS3220010B	20	± 25	10	250	480	17 000
MS3250006	50	± 25	6	250	480	17 000
MS3250006L	50	± 25	6	250	480	19 250
MS350R550	0.5	± 25	50	500	480	62 000
MS351R040	1	± 25	40	800	480	55 000
MS352R035	2	± 25	35	750	480	51 900
MS353R030	3	± 25	30	750	480	51 600
MS353R725	3.7	± 25	25	800	680	41 250
MS355R025	5	± 25	25	600	480	41 250
MS3510018	10	± 25	18	500	480	34 000
MS3510018D	10	± 25	18	1000	680	1000
MS3520010	20	± 25	10	500	480	34 000

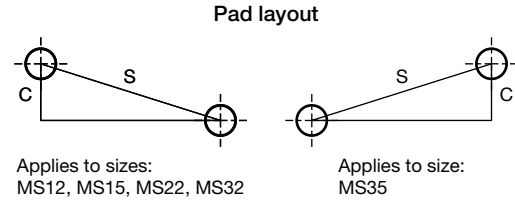
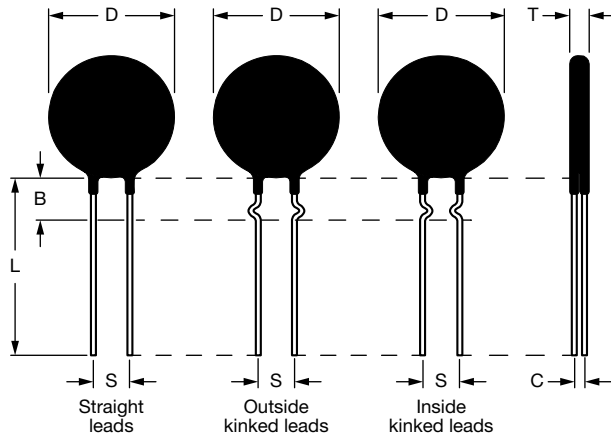

ELECTRICAL SPECIFICATIONS						
PART NUMBER	RESISTANCE AT 100 % MAX. CURRENT (Ω)	RESISTANCE AT 50 % MAX. CURRENT (Ω)	BODY TEMP. AT 100 % MAX. CURRENT (°C)	DISSIPATION FACTOR (mW/°C)	THERMAL TIME CONSTANT (s)	MATERIAL TYPE (FOR BETA AND CURVE)
MS1215102	1.34	3.5	162	12.7	47	I
MS1515004	0.20	0.85	144	49.4	114	G
MS1515004A	0.20	0.85	144	49.4	114	G
MS1530004	0.23	0.87	150	49.4	114	H
MS1540004	0.28	0.95	154	49.4	114	I
MS1566003	0.40	1.75	134	49.4	114	M
MS225R015	0.35	0.13	194	45.4	112	C
MS2210008	0.01	0.18	194	55	112	G
MS2210008B	0.11	0.18	194	55	112	G
MS2220005	0.19	0.48	170	42.5	114	H
MS2220005A324	0.19	0.485	170	42.5	114	H
MS2230005	0.23	0.65	174	45.4	112	H
MS2250004	0.42	0.79	159	47.8	119	H
MS2250004B	0.42	0.79	159	47.8	119	H
MS2275004	0.49	0.9	169	51.8	122	M
MS2212102	1.78	3.65	155	75.4	124	M
MS2212103	1.28	2.65	165	75.4	124	M
MS2212103B	1.28	2.65	165	75.4	124	M
MS2212104	0.75	1.98	175	75.4	124	M
MS2212104B	0.75	1.98	175	75.4	124	M
MS2222103	1.00	2.75	144	45.4	114	L
MS320R536	0.01	0.02	214	45.4	194	A
MS320R540	0.01	0.01	224	79.8	194	A
MS321R030	0.01	0.04	190	45.4	194	B
MS321R036	0.01	0.02	255	72	285	B
MS322R025	0.02	0.06	236	65.4	208	C
MS325R020	0.028	0.1	204	55.4	194	G
MS325R020B	0.028	0.1	204	55.4	194	G
MS327R015	0.049	0.16	214	63.7	194	G
MS3210015	0.056	0.22	224	63.7	194	H
MS3210015B	0.056	0.22	224	63.7	194	H
MS3215012	0.07	0.31	229	75.4	199	I
MS3220008	0.22	0.89	204	45.5	194	I
MS3220008B	0.22	0.89	204	45.5	194	I
MS3220010	0.14	0.64	224	45.4	194	I
MS3220010B	0.14	0.64	224	45.4	194	I
MS3250006	0.33	0.7	177	75.4	294	I
MS3250006L	0.40	0.7	177	75.4	294	I
MS350R550	0.01	0.02	215	78.0	240	B
MS351R040	0.01	0.03	215	78	240	B
MS352R035	0.014	0.04	235	96	65	C
MS353R030	0.03	0.07	215	78	240	C
MS353R725	0.037	0.09	215	102.5	134	H
MS355R025	0.03	0.08	212	102.5	134	H
MS3510018	0.05	0.15	215	78	240	I
MS3510018D	0.05	0.15	215	78	240	I
MS3520010	0.1	0.48	235	80	65	M

MECHANICAL SPECIFICATIONS in millimeters

PART NUMBER	B	C	D	L	S	T	LEAD DIAMETER	STRAIGHT LEADS	LEAD STYLE
MS1215102	6.35 ± 0.6	6.5 ± 0.5	12.0 ± 1.0	38.0 ± 9.0	7.8 ± 1.0	8.5 ± 1.0	1.0 ± 0.1	5.0 max.	Straight
MS1515004	6.3 ± 0.6	6.5 ± 0.5	15.0 ± 1.0	38.0 ± 9.0	7.8 ± 2.0	7.0 ± 0.7	1.0 ± 0.1	5.0 ± 1.0	Straight
MS1515004A	6.3 ± 0.6	6.5 ± 0.5	15.0 ± 1.0	38.0 ± 9.0	7.8 ± 2.0	7.0 ± 0.7	1.0 ± 0.1	5.0 ± 1.0	Inside kinked
MS1530004	4.0 nom.	6.0 nom.	17.0 max.	38.0 nom.	7.8 nom.	8.0 max.	1.0 nom.	4.0 max.	Straight
MS1540004	4.0 nom.	6.0 nom.	17.0 max.	38.0 nom.	7.8 nom.	8.0 max.	1.0 nom.	4.0 max.	Straight
MS1566003	6.3 ± 0.6	6.5 ± 0.5	15.0 ± 1.0	38.0 ± 9.0	7.8 ± 2.0	7.0 ± 0.7	1.0 ± 0.1	5.0 ± 1.0	Straight
MS225R015	7.5 ± 2.5	3.82 ± 1.0	20.0 ± 1.0	38.0 ± 9.0	7.8 ± 2.0	7.0 ± 0.7	1.0 ± 0.1	5.0 ± 0.1	Straight
MS2210008	9.22 nom.	3.82 nom.	23.0 max.	38.0 nom.	7.8 nom.	9.5 max.	1.0 nom.	5.0 max.	Straight
MS2210008B	9.22 nom.	3.82 nom.	23.0 max.	38.0 nom.	9.5 ± 1.0	9.5 max.	1.0 nom.	5.0 max.	Outside kinked
MS2220005	9.2 nom.	6.35 nom.	23.0 max.	38.0 nom.	7.8 nom.	8.0 max.	1.0 nom.	4.0 max.	Straight
MS2220005A324	9.35 ± 0.85	3.82 ± 1.0	20.0 ± 1.0	38.0 ± 9.0	7.8 ± 2.0	5.0 ± 0.2	1.0 ± 0.1	5.0 ± 1.0	Straight
MS2230005	9.2 nom.	6.7 nom.	23.0 max.	38.0 nom.	7.8 nom.	9.0 max.	1.0 nom.	4.0 max.	Straight
MS2250004	9.2 nom.	6.7 nom.	23.0 max.	38.0 nom.	7.8 nom.	10.0 max.	1.0 nom.	4.0 max.	Straight
MS2250004B	9.2 nom.	6.7 nom.	23.0 max.	38.0 nom.	9.5 ± 1.0	10.0 max.	1.0 nom.	4.0 max.	Outside kinked
MS2275004	9.2 nom.	6.9 nom.	23.0 max.	38.0 nom.	7.8 nom.	9.0 max.	1.0 nom.	4.0 max.	Straight
MS2212102	9.2 nom.	7.6 nom.	23.0 max.	38.0 nom.	7.8 nom.	10.0 max.	1.0 nom.	4.0 max.	Straight
MS2212103	9.2 nom.	7.6 nom.	23.0 max.	38.0 nom.	7.8 nom.	10.0 max.	1.0 nom.	4.0 max.	Straight
MS2212103B	9.2 nom.	7.6 nom.	23.0 max.	38.0 nom.	9.5 ± 1.0	10.0 max.	1.0 nom.	4.0 max.	Outside kinked
MS2212104	9.2 nom.	7.6 nom.	23.0 max.	38.0 nom.	7.8 nom.	10.0 max.	1.0 nom.	4.0 max.	Straight
MS2212104B	9.2 nom.	7.6 nom.	23.0 max.	38.0 nom.	9.5 ± 1.0	10.0 max.	1.0 nom.	4.0 max.	Outside kinked
MS2222103	9.2 nom.	7.3 nom.	23.0 max.	38.0 nom.	7.8 nom.	10.0 max.	1.0 nom.	4.0 max.	Straight
MS320R536	7.8 nom.	4.5 nom.	31.0 max.	38.0 nom.	7.8 nom.	7.0 max.	1.0 nom.	4.0 max.	Straight
MS320R540	7.8 nom.	4.5 nom.	31.0 max.	38.0 nom.	7.8 nom.	7.0 max.	1.0 nom.	4.0 max.	Straight
MS321R030	11.5 nom.	3.82 nom.	30.0 max.	38.0 nom.	7.8 nom.	7.0 max.	1.0 nom.	5.0 max.	Straight
MS321R036	7.8 nom.	4.5 nom.	31.0 max.	38.0 nom.	7.8 nom.	7.0 max.	1.0 nom.	5.0 max.	Straight
MS322R025	7.8 nom.	6.7 nom.	31.0 max.	38.0 nom.	7.8 nom.	10.0 max.	1.0 nom.	4.0 max.	Straight
MS325R020	7.8 nom.	5.7 nom.	31.0 max.	38.0 nom.	7.8 nom.	8.0 max.	1.0 nom.	5.0 max.	Straight
MS325R020B	7.8 nom.	5.7 nom.	31.0 max.	38.0 nom.	9.5 ± 1.0	8.0 max.	1.0 nom.	5.0 max.	Outside kinked
MS327R015	7.8 nom.	6.7 nom.	31.0 max.	38.0 nom.	7.8 nom.	10.0 max.	1.0 nom.	4.0 max.	Straight
MS3210015	7.8 nom.	6.75 nom.	31.0 max.	38.0 nom.	7.8 nom.	9.3 max.	1.0 nom.	6.0 max.	Straight
MS3210015B	7.8 nom.	6.75 nom.	31.0 max.	38.0 nom.	9.5 ± 1.0	9.3 max.	1.0 nom.	6.0 max.	Outside kinked
MS3215012	7.8 nom.	6.7 nom.	31.0 max.	38.0 nom.	7.8 nom.	10.0 max.	1.0 nom.	4.0 max.	Straight
MS3220008	7.8 nom.	6.7 nom.	31.0 max.	38.0 nom.	7.8 nom.	10.0 max.	1.0 nom.	4.0 max.	Straight
MS3220008B	7.8 nom.	6.7 nom.	31.0 max.	38.0 nom.	9.5 ± 1.0	10.0 max.	1.0 nom.	4.0 max.	Outside kinked
MS3220010	7.8 nom.	6.7 nom.	31.0 max.	38.0 nom.	7.8 nom.	10.0 max.	1.0 nom.	4.0 max.	Straight

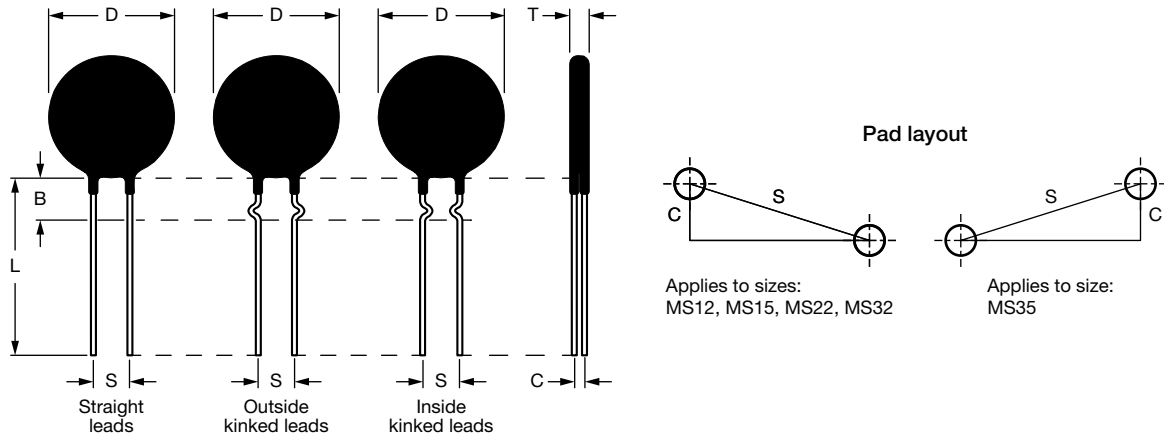
MECHANICAL SPECIFICATIONS in millimeters

PART NUMBER	B	C	D	L	S	T	LEAD DIAMETER	STRAIGHT LEADS	LEAD STYLE
MS3220010B	7.8 nom.	6.7 nom.	31.0 max.	38.0 nom.	9.5 ± 1.0	10.0 max.	1.0 nom.	4.0 max.	Outside kinked
MS3250006	9.35 nom.	3.82 nom.	30.0 max.	38.0 nom.	7.8 nom.	10.0 max.	1.2 nom.	5.0 max.	Straight
MS3250006L	-	6.7 nom.	31.0 max.	38.0 nom.	7.8 nom.	8.3 max.	1.2 nom.	5.0 max.	Straight
MS350R550	-	5.2 nom.	37.0 max.	40.0 nom.	19.0 nom.	9.0 max.	2.7 ± 0.1	7.0 max.	Straight
MS351R040	-	7.5 nom.	37.0 max.	39.0 nom.	19.0 nom.	11.0 max.	2.5 nom.	7.0 max.	Straight
MS352R035	-	7.3 ± 0.5	35.0 ± 2.0	32.0 ± 5.0	19.0 ± 1.0	10.0 ± 1.0	2.5 nom.	9.0 max.	Straight
MS353R030	-	7.5 nom.	37.0 max.	39.0 nom.	19.0 nom.	10.0 max.	2.5 nom.	7.0 max.	Straight
MS353R725	-	14.0 ± 2.0	37.0 max.	38.0 nom.	19.1 ± 2.0	15.0 ± 2.0	2.5 ± 0.2	-	Straight
MS355R025	-	7.5 nom.	38.0 max.	40.0 nom.	19.0 nom.	10.0 max.	2.5 nom.	7.0 max.	Straight
MS3510018	-	7.5 nom.	37.0 max.	40.0 nom.	19.0 nom.	11.0 max.	2.5 nom.	7.0 max.	Straight
MS3510018D	-	13.0 ± 1.0	35.0 ± 2.5	39.0 ± 5.0	19.0 ± 1.0	18.0 ± 2.0	2.6 ± 0.1	9.0 max.	Straight
MS3520010	-	7.5 nom.	37.0 max.	40.0 nom.	19.0 nom.	11.0 max.	2.5 nom.	7.0 max.	Straight

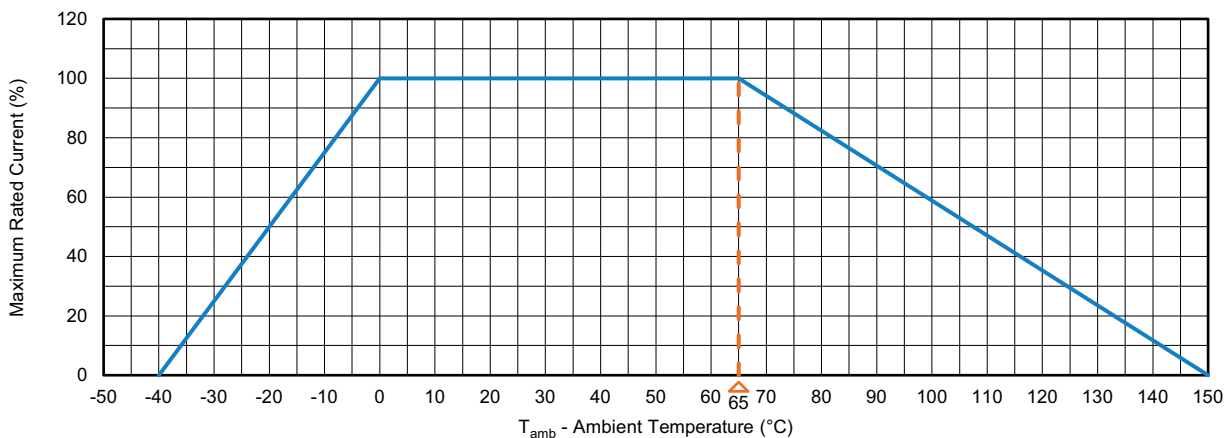
DERATING CURVE



Disclaimer

ALL PRODUCT, PRODUCT SPECIFICATIONS AND DATA ARE SUBJECT TO CHANGE WITHOUT NOTICE TO IMPROVE RELIABILITY, FUNCTION OR DESIGN OR OTHERWISE.

Vishay Intertechnology, Inc., its affiliates, agents, and employees, and all persons acting on its or their behalf (collectively, "Vishay"), disclaim any and all liability for any errors, inaccuracies or incompleteness contained in any datasheet or in any other disclosure relating to any product.

Vishay makes no warranty, representation or guarantee regarding the suitability of the products for any particular purpose or the continuing production of any product. To the maximum extent permitted by applicable law, Vishay disclaims (i) any and all liability arising out of the application or use of any product, (ii) any and all liability, including without limitation special, consequential or incidental damages, and (iii) any and all implied warranties, including warranties of fitness for particular purpose, non-infringement and merchantability.

Statements regarding the suitability of products for certain types of applications are based on Vishay's knowledge of typical requirements that are often placed on Vishay products in generic applications. Such statements are not binding statements about the suitability of products for a particular application. It is the customer's responsibility to validate that a particular product with the properties described in the product specification is suitable for use in a particular application. Parameters provided in datasheets and / or specifications may vary in different applications and performance may vary over time. All operating parameters, including typical parameters, must be validated for each customer application by the customer's technical experts. Product specifications do not expand or otherwise modify Vishay's terms and conditions of purchase, including but not limited to the warranty expressed therein.

Hyperlinks included in this datasheet may direct users to third-party websites. These links are provided as a convenience and for informational purposes only. Inclusion of these hyperlinks does not constitute an endorsement or an approval by Vishay of any of the products, services or opinions of the corporation, organization or individual associated with the third-party website. Vishay disclaims any and all liability and bears no responsibility for the accuracy, legality or content of the third-party website or for that of subsequent links.

Vishay products are not designed for use in life-saving or life-sustaining applications or any application in which the failure of the Vishay product could result in personal injury or death unless specifically qualified in writing by Vishay. Customers using or selling Vishay products not expressly indicated for use in such applications do so at their own risk. Please contact authorized Vishay personnel to obtain written terms and conditions regarding products designed for such applications.

No license, express or implied, by estoppel or otherwise, to any intellectual property rights is granted by this document or by any conduct of Vishay. Product names and markings noted herein may be trademarks of their respective owners.