

■ 绕线型片式陶瓷电感器

Wire Wound Chip Ceramic Inductors

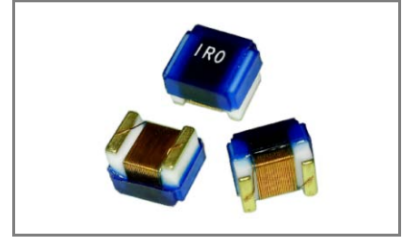

◆ 特征 Feature

- * 体积小, 适合高密度表面贴装
Small Size For SMT.
- * 采用端电极结构, 很好地抑制了引线引起的寄生元件效应, 具有高可靠性
Using Terminal Electrode Structure To Restrain The Parasitic Component Effect Quite Caused By Lead.
- * 精度高、Q 值高
High Q Value And Tight Inductance Tolerance.
- * 优良的焊接性和耐焊性
Excellent In Solder Ability And Heat Resistance.

◆ 应用 Application

- * 移动通信、PDA
Portable Communication Equipment And PDA.
- * 各种高频回路
High Speed Electronic Device.
- * 无线通信模块,无线局域网 W-LAN.
RF Wireless Data Communication Module,W-LAN.

◆ 型号表示法 Part Number

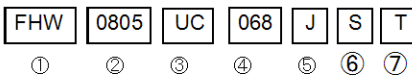

- ① 产品类型 Product Type:
FHW: 绕线型片式电感器系列
FHW: Wire Wound Inductor Series
- ② 尺寸 Dimensions: 0603(1.6×0.8mm)、0805(2.0×1.2mm)、1008(2.5×2.0mm) 、1210(3.2×2.5mm)
- ③ 材料代号 Material Code: UC/HC---陶瓷芯 Ceramic Core
- ④ 标称电感量 Inductance: 1N0=1.0nH、010=10nH、R10=100nH、1R0=1.0μH、100=10μH
- ⑤ 标称电感值偏差 Tolerance: G---±2%; J---±5%; K---±10%; M---±20%
- ⑥ 电极表面镀层材料 Terminal: G---金端头 Gold; S---锡端头 Tin
- ⑦ 包装 Packaging: T: 编带包装 Tape & Reel

◆ 产品结构 Product Structure

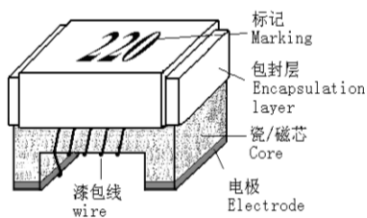

序号 No.	部位 Component	材料 Material
1	瓷芯 Core	陶瓷体 Al ₂ O ₃
2	电极 Electrode	锡或金 Sn or Au
3	漆包线 wire	铜 Cu
4	包封层 encapsulation layer	树脂 UV Adhesive
5	标识 Marking	油墨 UV printing ink
* 0603系列产品无印标识 0603 series products are not marked.		

◆规格尺寸 Dimension

单位 Unit: mm (inch)

Size	L (Max)	W (Max)	T (Max)	A(typ)	B(typ)	C(typ)	D(typ)	E(typ)
1608 (0603)	1.78 (0.070)	1.10 (0.043)	0.95 (0.037)	0.76 (0.030)	0.30 (0.012)	1.02 (0.040)	0.64 (0.025)	0.64 (0.025)
2012 (0805)	2.30 (0.091)	1.70 (0.067)	1.52 (0.060)	1.27 (0.050)	0.50 (0.020)	1.78 (0.070)	1.02 (0.040)	0.76 (0.030)
2520 (1008)	2.92 (0.115)	2.79 (0.110)	2.10 (0.083)	2.00 (0.079)	0.50 (0.020)	2.54 (0.100)	1.02 (0.040)	1.27 (0.050)
3225 (1210)	3.50 (0.138)	2.90 (0.114)	2.25 (0.088)	2.10 (0.083)	0.50 (0.020)	2.54 (0.100)	1.02 (0.040)	1.78 (0.070)

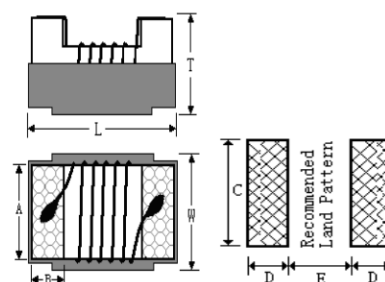

◆工作温度范围 Operating Temperature Range

工作温度范围: -40°C~+125°C

Operating Temperature Range: -40°C~+125°C

◆电性能参数 Electrical Characteristics

* 测试条件 Testing conditions

电感量/Q 值 Inductance/ Q: HP4286A 或 E4982A 电桥或等同测量仪器, 测试电压 500mV. HP4286A or E4982A bridge or equivalent measuring instrument, test voltage 500mV.

直流电阻 Rdc: HP4286A、RM3542 或等同测量仪器. HP4286A、RM3542 or equivalent measuring instrument.

额定电流 Rated current: 施加额定电流, 产品表面温升不超过 20°C. 使用直流电流源、LCR 测试仪与温表测试. Apply the rated current, and the surface temperature rise of the product shall not exceed 20°C. Use a DC current source, LCR tester, and temperature gauge for testing.

0603 Type

型号 Part NO	电感量 Inductance (nH)	偏差范围 Tolerance	Q 值 Q (Min)	自谐振频率 SRF (MHZ) Min	最大直流电阻 Rdc(Ω) Max	额定电流 Idc(mA) Max
FHW0603UC1N6□ST	1.6@250MHz	C,S,D,K	18@250MHz	12500	0.040	700
FHW0603UC1N7□ST	1.7@250MHz	B,C,S,D,K	18@250MHz	12500	0.045	700
FHW0603UC1N8□ST	1.8@250MHz	C,S,D,K	16@250MHz	12500	0.045	700
FHW0603UC2N0□ST	2.0@250MHz	C,S,D,K	12@250MHz	10000	0.090	700
FHW0603UC2N2□ST	2.2@250MHz	C,S,D,K	12@250MHz	10000	0.090	700
FHW0603UC3N3□ST	3.3@250MHz	S,D,K	20@250MHz	5900	0.075	700
FHW0603UC3N6□ST	3.6@250MHz	B,C,S,D,K	22@250MHz	5900	0.075	700
FHW0603UC3N9□ST	3.9@250MHz	B,C,S,D,K	22@250MHz	6900	0.080	700
FHW0603UC4N3□ST	4.3@250MHz	B,C,S,D,K	22@250MHz	5900	0.075	700
FHW0603UC4N7□ST	4.7@250MHz	B,C,S,D,K	20@250MHz	5800	0.116	700
FHW0603UC5N1□ST	5.1@250MHz	B,C,S,D,K	20@250MHz	5700	0.120	700
FHW0603UC6N0□ST	6.0@250MHz	C,S,D,K	27@250MHz	5700	0.110	700
FHW0603UC6N2□ST	6.2@250MHz	C,S,D,K	27@250MHz	5700	0.110	700
FHW0603UC6N8□ST	6.8@250MHz	G,J,K	27@250MHz	5800	0.110	700
FHW0603UC7N5□ST	7.5@250MHz	G,J,K	28@250MHz	4800	0.110	700
FHW0603UC8N2□ST	8.2@250MHz	G,J,K	28@250MHz	4700	0.120	700

WIRE WOUND CHIP INDUCTORS

FHW0603UC8N7□ST	8.7@250MHz	G,J,K	28@250MHz	4600	0.120	700
FHW0603UC9N1□ST	9.1@250MHz	G,J,K	26@250MHz	4500	0.150	700
FHW0603UC9N5□ST	9.5@250MHz	G,J,K	26@250MHz	5400	0.150	700
FHW0603UC010□ST	10@250MHz	G,J,K	31@250MHz	4800	0.130	700
FHW0603UC011□ST	11@250MHz	G,J,K	33@250MHz	4000	0.130	700
FHW0603UC012□ST	12@250MHz	G,J,K	35@250MHz	4000	0.130	700
FHW0603UC013□ST	13@250MHz	G,J,K	30@250MHz	4000	0.140	700
FHW0603UC014□ST	14@250MHz	G,J,K	35@250MHz	4000	0.140	700
FHW0603UC015□ST	15@250MHz	G,J,K	30@250MHz	4000	0.150	700
FHW0603UC016□ST	16@250MHz	G,J,K	34@250MHz	3300	0.160	700
FHW0603UC018□ST	18@250MHz	G,J,K	35@250MHz	3100	0.170	700
FHW0603UC020□ST	20@250MHz	G,J,K	38@250MHz	3000	0.190	700
FHW0603UC022□ST	22@250MHz	G,J,K	38@250MHz	3000	0.190	700
FHW0603UC024□ST	24@250MHz	G,J,K	37@250MHz	2650	0.200	700
FHW0603UC025□ST	25@250MHz	G,J,K	38@250MHz	2600	0.210	700
FHW0603UC027□ST	27@250MHz	G,J,K	36@250MHz	2800	0.220	600
FHW0603UC030□ST	30@250MHz	G,J,K	37@250MHz	2250	0.220	600
FHW0603UC033□ST	33@250MHz	G,J,K	36@250MHz	2300	0.220	600
FHW0603UC036□ST	36@250MHz	G,J,K	36@250MHz	2080	0.250	600
FHW0603UC039□ST	39@250MHz	G,J,K	40@250MHz	2200	0.250	600
FHW0603UC043□ST	43@250MHz	G,J,K	36@250MHz	2000	0.280	600
FHW0603UC047□ST	47@200MHz	G,J,K	36@200MHz	2000	0.280	600
FHW0603UC049□ST	49@200MHz	G,J,K	36@200MHz	2000	0.280	600
FHW0603UC050□ST	50@200MHz	G,J,K	36@200MHz	1900	0.295	600
FHW0603UC051□ST	51@200MHz	G,J,K	36@200MHz	1900	0.300	600
FHW0603UC056□ST	56@200MHz	G,J,K	38@200MHz	1900	0.280	600
FHW0603UC068□ST	68@200MHz	G,J,K	36@200MHz	1700	0.340	600
FHW0603UC072□ST	72@150MHz	G,J,K	34@150MHz	1700	0.530	400
FHW0603UC075□ST	75@150MHz	G,J,K	30@150MHz	1400	0.600	400
FHW0603UC082□ST	82@150MHz	G,J,K	34@150MHz	1700	0.550	400
FHW0603UC091□ST	91@150MHz	G,J,K	30@150MHz	1400	0.630	400
FHW0603UCR10□ST	100@150MHz	G,J,K	30@150MHz	1400	0.630	400
FHW0603UCR11□ST	110@150MHz	G,J,K	32@150MHz	1350	0.670	300
FHW0603UCR12□ST	120@150MHz	G,J,K	32@150MHz	1300	0.730	300
FHW0603UCR13□ST	130@150MHz	G,J,K	28@150MHz	1200	1.300	250
FHW0603UCR15□ST	150@150MHz	G,J,K	28@150MHz	990	0.800	280
FHW0603UCR16□ST	160@100MHz	G,J,K	25@100MHz	990	1.250	250
FHW0603UCR18□ST	180@100MHz	G,J,K	25@100MHz	990	1.450	240
FHW0603UCR20□ST	200@100MHz	G,J,K	25@100MHz	900	1.550	200
FHW0603UCR22□ST	220@100MHz	G,J,K	25@100MHz	900	2.100	200
FHW0603UCR25□ST	250@100MHz	G,J,K	25@100MHz	822	3.550	120
FHW0603UCR27□ST	270@100MHz	G,J,K	24@100MHz	900	2.300	170
FHW0603UCR30□ST	300@100MHz	G,J,K	24@100MHz	1000	3.000	100
FHW0603UCR33□ST	330@100MHz	G,J,K	25@100MHz	900	3.890	100
FHW0603UCR36□ST	360@100MHz	G,J,K	25@100MHz	800	4.350	100
FHW0603UCR39□ST	390@100MHz	G,J,K	25@100MHz	800	4.350	100
FHW0603UCR47□ST	470@100MHz	G,J,K	25@100MHz	700	7.000	75
FHW0603UCR56□ST	560@100MHz	G,J,K	27@100MHz	650	8.100	70

WIRE WOUND CHIP INDUCTORS

0805 Type

型号 Part NO	电感量 Inductance (nH)	偏差范围 Tolerance	Q 值 Q (Min)	自谐振频率 SRF (MHZ) Min	最大直流电阻 Rdc(Ω) Max	额定电流 Idc(mA) Max
FHW0805UC2N2□ GT	2.2@250MHz	K	50@1500MHz	8500	0.030	800
FHW0805UC2N7□ GT	2.7@250MHz	J,K	50@1500MHz	8000	0.045	800
FHW0805UC3N3□ GT	3.3@250MHz	K	35@1500MHz	7900	0.090	600
FHW0805UC4N7□ GT	4.7@250MHz	K	40@1000MHz	6000	0.050	600
FHW0805UC5N6□ GT	5.6@250MHz	J,K	50@1000MHz	5500	0.065	600
FHW0805UC6N8□ GT	6.8@250MHz	J,K	50@1000MHz	5500	0.110	600
FHW0805UC8N2□ GT	8.2@250MHz	J,K	35@1000MHz	4700	0.200	600
FHW0805UC010□ GT	10@250MHz	G,J,K	50@500MHz	4200	0.150	600
FHW0805UC012□ GT	12@250MHz	G,J,K	50@500MHz	4000	0.150	600
FHW0805UC015□ GT	15@250MHz	G,J,K	45@500MHz	3400	0.170	600
FHW0805UC018□ GT	18@250MHz	G,J,K	55@500MHz	3300	0.200	600
FHW0805UC022□ GT	22@250MHz	G,J,K	55@500MHz	2600	0.220	500
FHW0805UC027□ GT	27@250MHz	G,J,K	55@500MHz	2500	0.250	500
FHW0805UC033□ GT	33@250MHz	G,J,K	55@500MHz	2050	0.270	500
FHW0805UC039□ GT	39@250MHz	G,J,K	55@500MHz	2000	0.290	500
FHW0805UC047□ GT	47@200MHz	G,J,K	55@500MHz	1650	0.310	500
FHW0805UC056□ GT	56@200MHz	G,J,K	55@500MHz	1550	0.340	500
FHW0805UC068□ GT	68@200MHz	G,J,K	55@500MHz	1450	0.380	500
FHW0805UC075□ GT	75@200MHz	G,J,K	55@500MHz	1400	0.400	400
FHW0805UC082□ GT	82@150MHz	G,J,K	55@500MHz	1300	0.420	400
FHW0805UCR10□ GT	100@150MHz	G,J,K	50@500MHz	1200	0.460	400
FHW0805UCR12□ GT	120@150MHz	G,J,K	45@250MHz	1100	0.510	400
FHW0805UCR15□ GT	150@100MHz	G,J,K	45@250MHz	920	0.560	400
FHW0805UCR18□ GT	180@100MHz	G,J,K	45@250MHz	870	0.640	400
FHW0805UCR22□ GT	220@100MHz	G,J,K	40@250MHz	850	1.050	400
FHW0805UCR27□ GT	270@100MHz	G,J,K	40@250MHz	650	1.100	350
FHW0805UCR33□ GT	330@100MHz	G,J,K	40@250MHz	600	1.400	310
FHW0805UCR39□ GT	390@100MHz	G,J,K	40@250MHz	560	1.500	290
FHW0805UCR47□ GT	470@50MHz	J,K	33@100MHz	375	2.000	250
FHW0805UCR56□ GT	560@25MHz	J,K	23@50MHz	340	1.900	230
FHW0805UCR68□ GT	680@25MHz	J,K	23@50MHz	300	2.100	190
FHW0805UCR75□ GT	750@25MHz	J,K	23@50MHz	280	2.120	180
FHW0805UCR82□ GT	820@25MHz	J,K	23@50MHz	250	2.140	180
FHW0805UCR91□ GT	910@25MHz	J,K	20@50MHz	220	2.280	180
FHW0805UC1R0□ GT	1000@25MHz	J,K	20@50MHz	200	2.400	170
FHW0805UC1R2□ GT	1200@7.9MHz	J,K	18@50MHz	180	2.550	170
FHW0805UC1R5□ GT	1500@7.9MHz	J,K	18@50MHz	170	2.800	160
FHW0805UC1R8□ GT	1800@7.9MHz	J,K	18@50MHz	140	3.800	150
FHW0805UC2R2□ GT	2200@7.9MHz	J,K	16@7.9MHz	50	4.200	150

WIRE WOUND CHIP INDUCTORS

1008 Type

型号 Part NO	电感量 Inductance (nH)	偏差范围 Tolerance	Q 值 Q (Min)	自谐振频率 SRF (MHZ) Min	最大直流电阻 Rdc(Ω) Max	额定电流 Idc(mA) Max
FHW1008UC3N9□ GT	3.9@50MHz	J,K	50@1500MHz	6000	0.035	1000
FHW1008UC4N7□ GT	4.7@50MHz	J,K	50@1500MHz	6000	0.045	1000
FHW1008UC5N6□ GT	5.6@50MHz	J,K	30@1000MHz	6000	0.180	1000
FHW1008UC8N2□ GT	8.2 @50MHz	J,K	50@1000MHz	5000	0.050	1000
FHW1008UC010□ GT	10@50MHz	G,J,K	50@500MHz	4100	0.080	1000
FHW1008UC012□ GT	12@50MHz	G,J,K	50@500MHz	3300	0.090	1000
FHW1008UC015□ GT	15@50MHz	G,J,K	45@500MHz	2500	0.150	1000
FHW1008UC018□ GT	18@50MHz	G,J,K	50@350MHz	2500	0.110	1000
FHW1008UC022□ GT	22@50MHz	G,J,K	55@350MHz	2400	0.120	1000
FHW1008UC027□ GT	27@50MHz	G,J,K	55@350MHz	1600	0.130	1000
FHW1008UC033□ GT	33@50MHz	G,J,K	60@350MHz	1600	0.140	1000
FHW1008UC039□ GT	39@50MHz	G,J,K	60@350MHz	1500	0.150	1000
FHW1008UC047□ GT	47@50MHz	G,J,K	65@350MHz	1500	0.160	1000
FHW1008UC056□ GT	56@50MHz	G,J,K	65@350MHz	1100	0.180	1000
FHW1008UC068□ GT	68@50MHz	G,J,K	65@350MHz	1000	0.200	1000
FHW1008UC082□ GT	82@50MHz	G,J,K	60@350MHz	1000	0.220	1000
FHW1008UCR10□ GT	100@25MHz	G,J,K	60@350MHz	1000	0.560	650
FHW1008UCR12□ GT	120@25MHz	G,J,K	60@350MHz	950	0.630	650
FHW1008UCR15□ GT	150@25MHz	G,J,K	45@100MHz	800	0.700	580
FHW1008UCR18□ GT	180@25MHz	G,J,K	45@100MHz	640	0.770	620
FHW1008UCR22□ GT	220@25MHz	G,J,K	45@100MHz	620	0.840	500
FHW1008UCR27□ GT	270@25MHz	G,J,K	45@100MHz	600	0.910	500
FHW1008UCR33□ GT	330@25MHz	G,J,K	45@100MHz	500	1.050	450
FHW1008UCR39□ GT	390@25MHz	G,J,K	45@100MHz	480	1.120	470
FHW1008UCR47□ GT	470@25MHz	G,J,K	45@100MHz	450	1.190	470
FHW1008UCR56□ GT	560@25MHz	G,J,K	45@100MHz	415	1.330	400
FHW1008UCR68□ GT	680@25MHz	G,J,K	45@100MHz	375	1.470	400
FHW1008UCR82□ GT	820@25MHz	J,K	45@100MHz	250	1.610	400
FHW1008UC1R0□ GT	1000@25MHz	J,K	35@50MHz	210	1.750	370
FHW1008UC1R2□ GT	1200@7.9MHz	J,K	35@50MHz	200	2.000	310
FHW1008UC1R5□ GT	1500@7.9MHz	J,K	28@50MHz	180	2.300	330
FHW1008UC1R8□ GT	1800@7.9MHz	J,K	28@50MHz	160	2.600	300
FHW1008UC2R2□ GT	2200@7.9MHz	J,K	20@50MHz	90	2.800	280
FHW1008UC2R7□ GT	2700@7.9MHz	J,K	22@25MHz	80	3.200	290
FHW1008UC3R3□ GT	3300@7.9MHz	J,K	22@25MHz	70	3.400	290
FHW1008UC3R9□ GT	3900@7.9MHz	J,K	16@25MHz	60	3.600	260
FHW1008UC4R7□ GT	4700@7.9MHz	J,K	18@25MHz	60	4.000	260
FHW1008UC5R6□ GT	5600@7.9MHz	J,K	18@7.9MHz	55	7.600	240
FHW1008UC6R8□ GT	6800@7.9MHz	J,K	18@7.9MHz	50	8.200	200
FHW1008UC8R2□ GT	8200@7.9MHz	J,K	18@7.9MHz	40	8.200	170
FHW1008UC100□ GT	10000@7.9MHz	J,K	20@7.9MHz	40	9.100	160

1210 Type

型号 Part NO	电感量 Inductance (nH)	偏差范围 Tolerance	Q 值 Q (Min)	自谐振频率 SRF (MHZ) Min	最大直流电阻 Rdc(Ω) Max	额定电流 Idc(mA) Max
FHW1210HC3N9□ GT	3.9@100MHz	K	30@300MHz	6000	0.050	1000
FHW1210HC4N7□ GT	4.7@100MHz	J,K	30@300MHz	5800	0.065	1000
FHW1210HC8N2□ GT	8.2@100MHz	K	30@300MHz	5500	0.070	1000
FHW1210HC010□ GT	10@100MHz	G,J,K	40@300MHz	4000	0.080	1000
FHW1210HC012□ GT	12@100MHz	G,J,K	40@300MHz	3200	0.080	1000
FHW1210HC015□ GT	15@100MHz	J,K	40@300MHz	3200	0.100	1000
FHW1210HC018□ GT	18@100MHz	G,J,K	50@300MHz	2800	0.100	1000
FHW1210HC022□ GT	22@100MHz	G,J,K	50@300MHz	2000	0.100	1000
FHW1210HC027□ GT	27@100MHz	G,J,K	50@300MHz	1800	0.110	1000
FHW1210HC033□ GT	33@100MHz	G,J,K	55@300MHz	1800	0.110	1000
FHW1210HC039□ GT	39@100MHz	G,J,K	55@300MHz	1800	0.120	1000
FHW1210HC047□ GT	47@100MHz	G,J,K	55@300MHz	1500	0.130	1000
FHW1210HC056□ GT	56@100MHz	G,J,K	55@300MHz	1450	0.140	1000
FHW1210HC068□ GT	68@100MHz	G,J,K	55@300MHz	1200	0.150	900
FHW1210HC082□ GT	82@100MHz	G,J,K	55@300MHz	1000	0.200	900
FHW1210HCR10□ GT	100@100MHz	G,J,K	55@300MHz	900	0.210	850
FHW1210HCR12□ GT	120@100MHz	G,J,K	60@300MHz	800	0.210	800
FHW1210HCR15□ GT	150@100MHz	G,J,K	60@300MHz	780	0.250	750
FHW1210HCR18□ GT	180@50MHz	G,J,K	60@300MHz	760	0.300	700
FHW1210HCR22□ GT	220@50MHz	G,J,K	60@300MHz	650	0.320	670
FHW1210HCR27□ GT	270@50MHz	G,J,K	55@300MHz	620	0.340	630
FHW1210HCR33□ GT	330@50MHz	G,J,K	45@150MHz	600	0.380	590
FHW1210HCR39□ GT	390@50MHz	G,J,K	45@150MHz	510	0.580	530
FHW1210HCR47□ GT	470@50MHz	G,J,K	45@150MHz	500	0.800	490
FHW1210HCR56□ GT	560@35MHz	G,J,K	45@150MHz	420	1.100	460
FHW1210HCR68□ GT	680@35MHz	G,J,K	45@150MHz	400	1.200	430
FHW1210HCR75□ GT	750@35MHz	G,J,K	45@150MHz	380	1.700	400
FHW1210HCR82□ GT	820@35MHz	G,J,K	45@150MHz	370	1.820	400
FHW1210HC1R0□ GT	1000@35MHz	G,J,K	45@150MHz	340	1.850	320
FHW1210HC1R2□ GT	1200@35MHz	G,J,K	35@150MHz	220	1.870	300
FHW1210HC1R5□ GT	1500@7.9MHz	G,J,K	30@50MHz	160	1.950	310
FHW1210HC1R8□ GT	1800@7.9MHz	G,J,K	30@50MHz	160	2.250	310
FHW1210HC2R2□ GT	2200@7.9MHz	G,J,K	30@50MHz	110	2.410	310
FHW1210HC2R7□ GT	2700@7.9MHz	G,J,K	25@25MHz	100	2.850	300
FHW1210HC3R3□ GT	3300@7.9MHz	G,J,K	20@25MHz	85	3.120	300
FHW1210HC3R9□ GT	3900@7.9MHz	G,J,K	20@25MHz	80	3.600	290
FHW1210HC4R7□ GT	4700@7.9MHz	J,K	16@25MHz	60	4.000	280
FHW1210HC5R6□ GT	5600@7.9MHz	J,K	20@7.9MHz	60	5.000	250
FHW1210HC6R8□ GT	6800@7.9MHz	J,K	20@7.9MHz	55	8.000	230
FHW1210HC8R2□ GT	8200@7.9MHz	J,K	20@7.9MHz	50	8.600	170
FHW1210HC100□ GT	10000@7.9MHz	J,K	22@7.9MHz	20	6.800	200

注: 可根据客户需求做定制产品。Note: Customized products can be made according to customer needs.

◆ 产品特性曲线图 Product Characteristic Curve

0603 Type

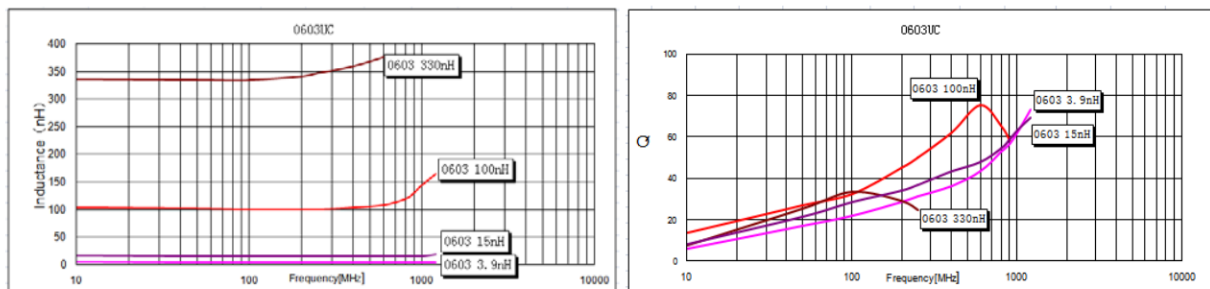

0805 Type

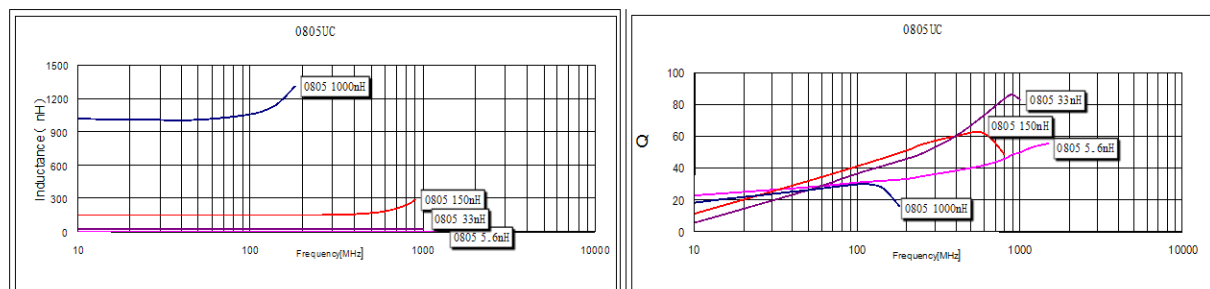

1008 Type

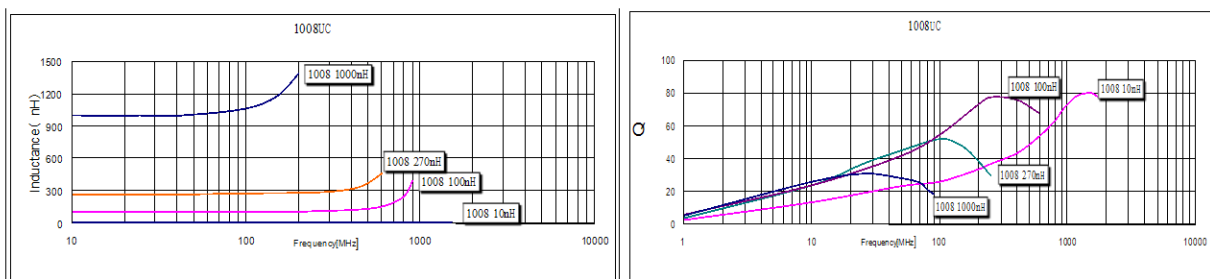

1210 Type

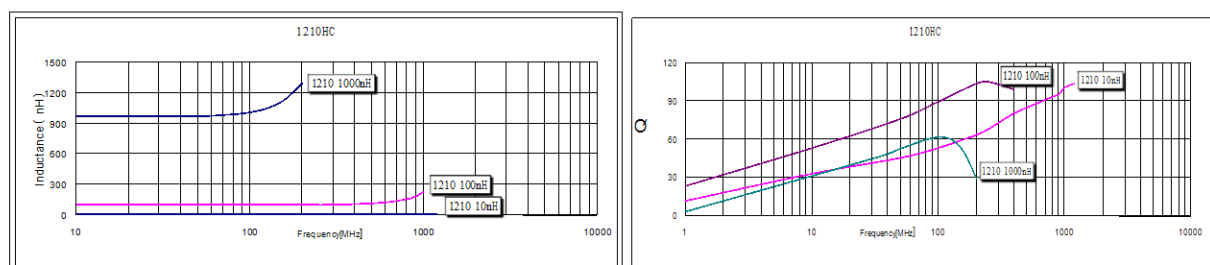

◆可靠性测试方法 Reliability Test Method

序号 No.	项目 Items	要求 Requirements	试验方法及备注 Test Methods and Remarks										
1	可焊性 Solder Ability	①外观无可见损伤痕迹 No visible mechanical damage. ②端电极表面焊锡覆盖率(不包含焊点)。 Electrode surface solder coverage (Except exposed wire) . FHW-UC/HC series : ≥ 90%。	在 245±3°C 熔融的焊锡(96.5%Sn/3.0%Ag/0.5%Cu) 中浸置 3±0.3s。 Dip pads in flux and dip in solder pot(96.5Sn/3.0Ag/0.5Cu)at 245±3°C for 3±0.3s.										
2	耐焊接热 Resistance To Soldering	①外观无可见损伤痕迹 No visible mechanical damage. ②感量变化不超过±5%; Inductance shall not change more than ±5%; ③Q值变化不超过±20%。 Q shall not change more than±20%.	在 260±5°C 熔融的焊锡(96.5%Sn/3.0%Ag/0.5%Cu) 中浸置 10±1s。 Dip pads in flux and dip in solder pot(96.5Sn/3.0Ag/0.5Cu)at 260±5°C for 10±1s.										
3	振动 Vibration	①外观无可见损伤痕迹 No visible mechanical damage. ②感量变化不超过±5%; Inductance shall not change more than ±5%; ③Q值变化不超过±20%。 Q shall not change more than±20%.	振幅 1.5mm, 频率 10Hz ~55Hz~10Hz(1 min.) , 每个方向(X、Y、Z)保持 2 小时。 Frequency 10Hz to 55Hz to 10Hz in a period of 1 minute.for 2h in each of three(X、Y、Z) axes.										
4	端电极强度 Adhesion Of Electrode	①试验后端电极无脱落; The end electrode did not fall off after the test. ②外观无可见损伤痕迹。 No visible mechanical damage.	将产品焊在 PCB 板上, 按下图、表所示方向及要求施加作用力。Weld the product on the PCB board, and apply force as shown in the diagram, direction and requirement.  <table border="1" data-bbox="997 1451 1444 1720"> <thead> <tr> <th>尺寸规格 Size</th> <th>施加力要求</th> </tr> </thead> <tbody> <tr> <td>0402UC Series</td> <td>5N</td> </tr> <tr> <td>0603UC Series</td> <td>7 N</td> </tr> <tr> <td>0805UC And Above Series</td> <td>20 N</td> </tr> <tr> <td colspan="2">Keep time: (10±1)s</td> </tr> </tbody> </table>	尺寸规格 Size	施加力要求	0402UC Series	5N	0603UC Series	7 N	0805UC And Above Series	20 N	Keep time: (10±1)s	
尺寸规格 Size	施加力要求												
0402UC Series	5N												
0603UC Series	7 N												
0805UC And Above Series	20 N												
Keep time: (10±1)s													
5	耐低温 Low Temperature Resistance	①外观无可见损伤痕迹 No visible mechanical damage. ②感量变化不超过±5%; Inductance shall not change more than ±5%; ③Q值变化不超过±20%。 Q shall not change more than±20%.	产品放置于温度-40±2°C的环境中存放 1000h Shall be subjected to-40±2°C for 1000h										

6	<p>耐高温 High Temperature Resistance</p>	<p>①外观无可见损伤痕迹 No visible mechanical damage. ②感量变化不超过±5%; Inductance shall not change more than ±5%; ③Q值变化不超过±20%。 Q shall not change more than±20%.</p>	<p>产品放置于温度+125±5°C的环境中存放 1000h Shall be subjected to +125±5°C for1000h</p>
7	<p>温度冲击 Temperature Shock</p>	<p>①外观无可见损伤痕迹 No visible mechanical damage. ②感量变化不超过±5%; Inductance shall not change more than ±5%; ③Q值变化不超过±20%。 Q shall not change more than±20%.</p>	<p>+125°C 30 分钟 ↔ -40°C 30 分钟, 循环 100 次; +125°C 30minutes ↔ -40°C 30minutes 100 Cycles.</p>
8	<p>高温负载 High Temperature Load</p>	<p>①外观无可见损伤痕迹 No visible mechanical damage. ②感量变化不超过±5%; Inductance shall not change more than ±5%; ③Q值变化不超过±20%。 Q shall not change more than±20%.</p>	<p>产品加额定电流在 125±2°C温度条件下存放 1000h shall be store at 125±2°C for 1000h with rated current applied.</p>
9	<p>恒定湿热 Static Humidity</p>	<p>①外观无可见损伤痕迹 No visible mechanical damage. ②感量变化不超过±5%; Inductance shall not change more than ±5%; ③Q值变化不超过±20%。 Q shall not change more than±20%.</p>	<p>将电感器放置于湿度 90%~95% RH,温度 60±2°C的环境中存放 1000h Inductors shall be subjected to 90%~95%RH. at 60±2°C for 1000h</p>
10	<p>抗弯强度 Bending Strength</p>	<p>外观无可见损伤痕迹; No visible mechanical damage.</p>	<p>①将电感器安装于试验基板上; 在垂直方向施加力。Install the inductor on the test substrate; Apply force in the vertical direction. ②该板应在 (1±0.5) mm/s 的弯曲速率向下弯曲 (2±0.2) mm, 保持时间(30±1) s。The epoxy plate should bend down to (2±0.2) mm at the bending rate of (1±0.5) mm/s, Keep time (30±1) sec.</p>

◆包装 Packaging

* 编带图 Taping drawings

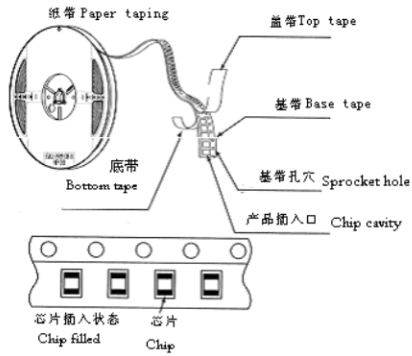

* 卷盘尺寸 Reel dimensions (Unit:mm)

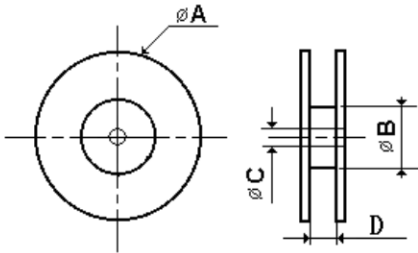

Part NO.	ΦA typ.	ΦB typ.	ΦC typ.	D typ.
0603-1210	178	60	13	8.4

* 导带及空格部分 Leader and blank portion

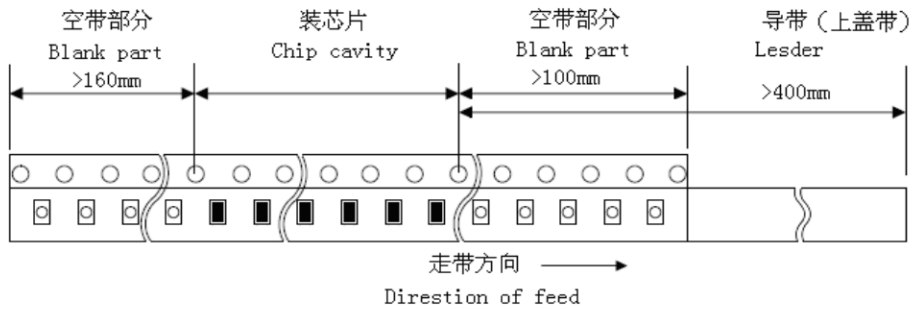

* 编带尺寸 Taping dimensions (Unit: mm)

纸带 Paper tape

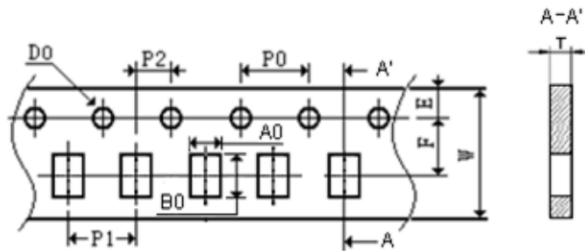

Part NO.	W	E	F	D0	P0	P1	P2	$P0 \times 10$	A0	B0	T
0402	8.00	1.75	3.50	1.55	4	2	2	40	0.74	1.23	0.68
0603	8.00	1.75	3.50	1.55	4	4	2	40	1.20	1.85	1.00

塑料胶带 Embossed tape

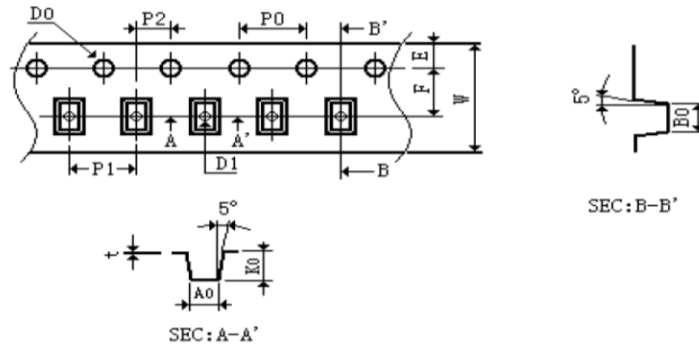

Part NO.	W	E	F	D0	D1	P0	P1	P2	P0×10	t	A0	B0	K0
0805	8.00	1.75	3.50	1.55	0.65	4	4	2	40	0.23	1.85	2.45	1.50
1008	8.00	1.75	3.50	1.55	0.65	4	4	2	40	0.25	2.73	2.90	2.34
1210	8.00	1.75	3.50	1.55	0.65	4	4	2	40	0.23	2.96	3.60	2.40

* 剥离力检验 Peeling off force

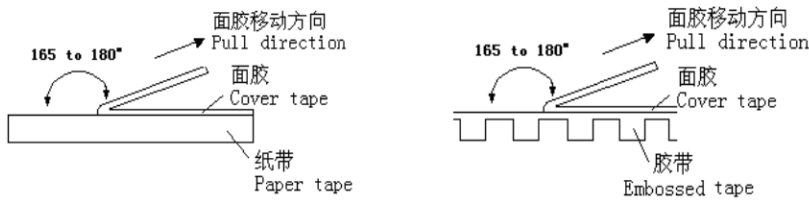

盖带的剥离力要求 Peeling required

0603~1210 series : 10g~80g

1812 series : 10g~100g

测试条件 Test condition

盖带剥离速度: 300mm/min±10%

Speed of peeling off : 300mm/min±10%

盖带剥离角度: 165°~180°

Angle of peeling off: 165°~180°

* 包装数量(单位: 粒) Packaging number (Unit: Pcs)

类型 Size		0603	0805	1008	1210
每卷数量 Per Reel		4000	3000	2000	2000
每盒数量 Per Box	3 卷盒	12000	9000	6000	6000
	5 卷盒	20000	15000	10000	10000
	10 卷盒	40000	30000	20000	20000
每箱数量 Per Case	1.5 盒箱	60000	45000	30000	30000
	2 盒箱	80000	60000	40000	40000
	3 盒箱	120000	90000	60000	60000
	4 盒箱	160000	120000	80000	80000
	6 盒箱	240000	180000	120000	120000

◆推荐焊接条件 Recommended Soldering Conditions

* 焊接条件 Soldering Conditions

本产品使用回流焊接法。

Applicable soldering process to the products is reflow soldering.

* 焊剂要求 Flux, Solder

使用松香基助焊剂，禁止使用卤化物含量超过 0.2(wt)% 的强酸性助焊剂。

Don't use highly acidic flux with halide content exceeding 0.2(wt)%(chlorine conversion value).

使用无铅焊料(96.5Sn /3.0Ag/0.5Cu)。

Using lead-free solder (96.5Sn /3.0Ag/0.5Cu)。

* 焊接要求 Soldering conditions

预热时，产品表温与焊料温度的温差最大不允许超出 150°C，焊接完冷却时，产品表温与溶剂温度之间的温差最大不超过 100°C。预热不足有可能引发产品表面裂纹，从而导致产品品质下降。

Pre-heating should be in such a way that the temperature difference between solder and ferrite surface is limited to 150°C max. Also cooling into solvent after soldering should be in such way that the temperature difference is limited to 100°C max. Un-enough pre-heating may cause cracks on the ferrite, resulting in the deterioration of product quality.

产品要在以下画出的曲线允许的范围内进行焊接。其它焊接条件可能引起产品电极的腐蚀。当焊接重复时，允许的时间为第一次做的累计时间。

Products should be soldered within the following allowable range indicated by the slanted line. The excessive soldering conditions may cause the corrosion of the electrode. When soldering is repeated, allowable time is the accumulated time.

* 回流焊曲线 Reflow soldering profile

预热条件: 150~200°C/60~120 秒

Preheat condition: 150 ~200°C/60~120sec

最大温度: 260°C

max temp: 260 °C

最高温的最大时间: 10 秒

max time at max temp: 10 sec

回流焊次数: 最多 3 次

Allowed Reflow time: 3x max

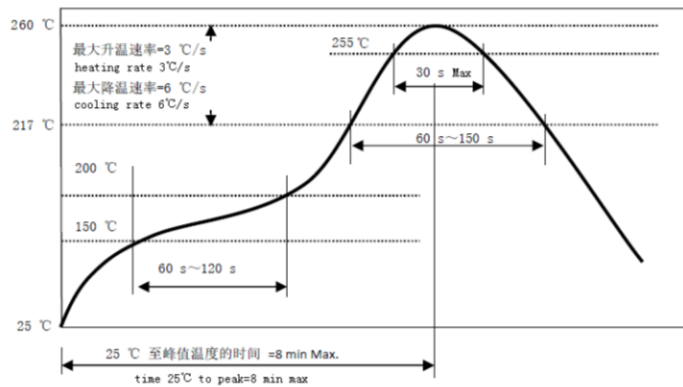

* 手工焊接 Iron soldering

烙铁温度: 350°C (Max)

功率: 最大为 30W

烙铁停留时间: <5S (注意不要将烙铁碰到产品线圈及包封层)。

Perform soldering at 350°C on 30W max.

Soldering Time: < 5S (Take care not to apply the tip of the soldering iron to the terminal electrodes) 。

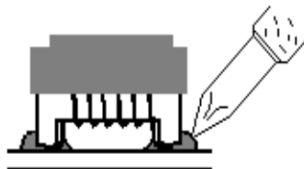

◆ 贮存方法 Storage Methods

* 存储期限 Storage period

距电感公司出厂检验时间 1 年内正常使用。若时间超过 1 年，应检查焊接性能后方可使用。

Please use the products within 1 year since the factory inspection before the delivery, the welding performance should be checked before use if the storage time exceeds 1 year.

* 存储条件 Storage conditions

存放货物的库房应满足以下条件：温度：-10 ~ +40°C，相对湿度：30 ~ 70%。

Products should be storage in the warehouse on the following conditions:

Temperature : -10~+40°C Humidity: 30~70% relative humidity

* 禁止将产品保管在腐蚀性物质中，如硫磺、氯气或酸，否则将引起端头氧化，导致降低焊接性。Don't keep products in corrosive gases such as sulfur, chlorine gas or acid, or it may cause oxidation of Electrodes resulting in poor solder ability.

* 为了避免受潮气、灰尘等物质的影响，产品应保管于货架上。

Products should be stored on the pallet for the prevention of the influence from humidity, dust and so on.

* 产品保管在库房中，应避免热冲击、振动以及直接光照等等。

Products should be stored in the warehouse without heat shock, vibration, direct sunlight and so on.

* 产品应密封包装。

Products should be stored under the airtight packaged condition.

◆ 使用注意事项 Precautions For Use

* 本承诺书保证我司产品作为一个单体时的质量情况，当我司产品被安装到贵司产品上时请保证贵司的产品已根据贵司的规范进行了有效评价和确认。

This product specification guarantees the quality of our product as a single unit, Please make sure that your product has been evaluated and confirmed against your specifications when our product is mounted to your product.

* 如果贵司对我司产品的试用已超过了本测试规范所界定的产品功能，对于此所引发的失效我司将不予保证。

We can't warrant against failure caused by any use of our product that deviates from the intended use as described in this product specification.

* 为防止断线，请不要使用锋利的物体接触线圈，如镊子。

Do not touch wire with sharp objects such as tweezers to prevent wire breakage.

<p>正确方法 Correct method (夹端头两端 Tweezers should support on both sides of the chip)</p>	<p>错误方法 Wrongly method (夹到产品线圈 Tweezers should not support on enameled wire of the chip)</p>
 	  