

# ESP32-S3

## esp-dev-kits Documentation



Release master  
Espressif Systems  
Mar 18, 2026

# Table of contents

<b>Table of contents</b>	<b>i</b>
<b>1 ESP32-S3-DevKitC-1</b>	<b>3</b>
1.1 ESP32-S3-DevKitC-1 v1.1	3
1.1.1 Getting Started	3
1.1.2 Hardware Reference	6
1.1.3 Hardware Revision Details	8
1.1.4 Related Documents	8
<b>2 ESP32-S3-USB-OTG</b>	<b>15</b>
2.1 ESP32-S3-USB-OTG	15
2.1.1 Getting Started	15
2.1.2 Hardware Reference	21
2.1.3 Related Documents	27
<b>3 ESP32-S3-LCD-EV-Board</b>	<b>29</b>
3.1 ESP32-S3-LCD-EV-Board v1.5	29
3.1.1 Board Overview	29
3.1.2 Start Application Development	39
3.1.3 Hardware Reference	39
3.1.4 Hardware Revision Details	43
3.1.5 Sample Request	43
3.1.6 Related Documents	45
<b>4 ESP-VoCat</b>	<b>63</b>
4.1 ESP-VoCat v1.2	63
4.1.1 Getting Started	64
4.1.2 Hardware Reference	71
4.1.3 Hardware Revision Details	74
4.1.4 Related Documents	76
<b>5 ESP-DualKey</b>	<b>89</b>
5.1 ESP-DualKey	89
5.1.1 Getting Started	90
5.1.2 Hardware Reference	92
5.1.3 Hardware Revision Details	93
5.1.4 Related Documents	93
<b>6 EOL (End of Life) Boards</b>	<b>95</b>
6.1 ESP32-S3-DevKitM-1	95
6.1.1 ESP32-S3-DevKitM-1	95
6.2 ESP32-S3-USB-Bridge	101
6.2.1 ESP32-S3-USB-Bridge	101
<b>7 Related Documentation and Resources</b>	<b>111</b>
7.1 Related Documentation	111
7.2 Developer Zone	111

7.3	Products . . . . .	112
7.4	Contact Us . . . . .	112
<b>8</b>	<b>Disclaimer and Copyright Notice</b>	<b>113</b>

This document provides detailed user guides and examples for ESP32-S3 series development boards.

---

**Note:** For the full list of Espressif development boards, please go to [ESP DevKits](#).

---



# Chapter 1

## ESP32-S3-DevKitC-1

The ESP32-S3-DevKitC-1 is an entry-level development board equipped with ESP32-S3-WROOM-1, ESP32-S3-WROOM-1U, or ESP32-S3-WROOM-2, a general-purpose Wi-Fi + Bluetooth® Low Energy MCU module that integrates complete Wi-Fi and Bluetooth Low Energy functions.

Most of the I/O pins on the module are broken out to the pin headers on both sides of this board for easy interfacing. Developers can either connect peripherals with jumper wires or mount ESP32-S3-DevKitC-1 on a breadboard.

### 1.1 ESP32-S3-DevKitC-1 v1.1

The older version: [ESP32-S3-DevKitC-1 v1.0](#)

This user guide will help you get started with ESP32-S3-DevKitC-1 and will also provide more in-depth information.

The ESP32-S3-DevKitC-1 is an entry-level development board equipped with ESP32-S3-WROOM-1, ESP32-S3-WROOM-1U, or ESP32-S3-WROOM-2, a general-purpose Wi-Fi + Bluetooth® Low Energy MCU module that integrates complete Wi-Fi and Bluetooth Low Energy functions.

Most of the I/O pins on the module are broken out to the pin headers on both sides of this board for easy interfacing. Developers can either connect peripherals with jumper wires or mount ESP32-S3-DevKitC-1 on a breadboard.

Fig. 1: ESP32-S3-DevKitC-1 with ESP32-S3-WROOM-1 Module

The document consists of the following major sections:

- [Getting started](#): Overview of the board and hardware/software setup instructions to get started.
- [Hardware Reference](#): More detailed information about the board's hardware.
- [Hardware Revision Details](#): Revision history, known issues, and links to user guides for previous versions (if any) of the board.
- [Related Documents](#): Links to related documentation.

#### 1.1.1 Getting Started

This section provides a brief introduction of ESP32-S3-DevKitC-1, instructions on how to do the initial hardware setup and how to flash firmware onto it.

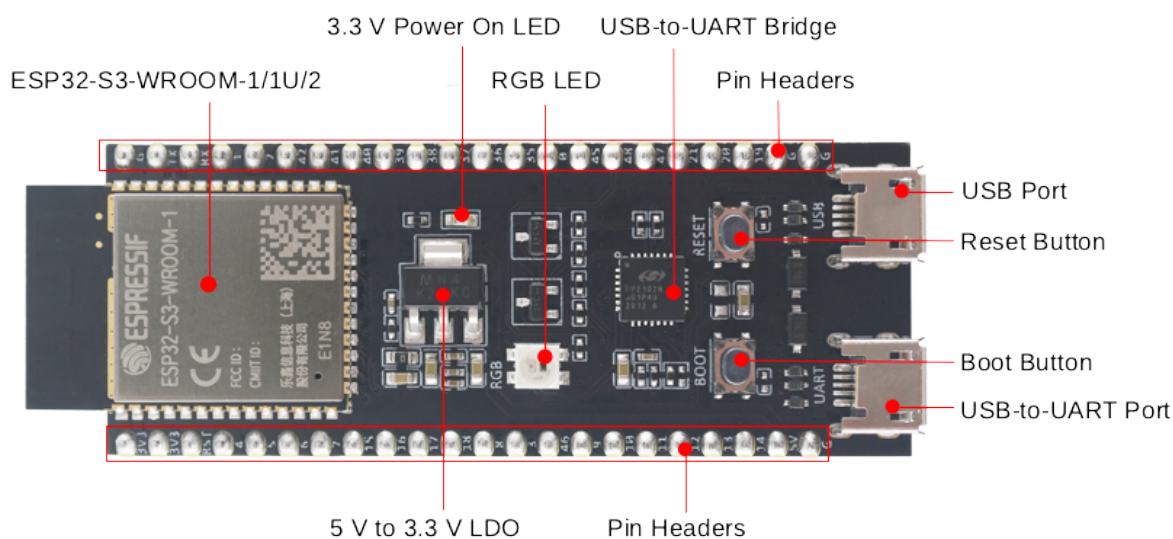

Fig. 2: ESP32-S3-DevKitC-1 - front

### Description of Components

The key components of the board are described in a counter-clockwise direction.

Key Component	Description
ESP32-S3-WROOM-1/1U/2	ESP32-S3-WROOM-1, ESP32-S3-WROOM-1U, and ESP32-S3-WROOM-2 are powerful, generic Wi-Fi + Bluetooth Low Energy MCU modules that have a rich set of peripherals. They provide acceleration for neural network computing and signal processing workloads. ESP32-S3-WROOM-1 and ESP32-S3-WROOM-2 comes with a PCB antenna. ESP32-S3-WROOM-1U comes with an external antenna connector.
5 V to 3.3 V LDO	Power regulator that converts a 5 V supply into a 3.3 V output.
Pin Headers	All available GPIO pins (except for the SPI bus for flash) are broken out to the pin headers on the board for easy interfacing and programming. For details, please see <a href="#">Header Block</a> .
USB-to-UART Port	A Micro-USB port used for power supply to the board, for flashing applications to the chip, as well as for communication with the chip via the on-board USB-to-UART bridge.
Boot Button	Download button. Holding down <b>Boot</b> and then pressing <b>Reset</b> initiates Firmware Download mode for downloading firmware through the serial port.
Reset Button	Press this button to restart the system.
USB Port	ESP32-S3 full-speed USB OTG interface, compliant with the USB 1.1 specification. The interface is used for power supply to the board, for flashing applications to the chip, for communication with the chip using USB 1.1 protocols, as well as for JTAG debugging.
USB-to-UART Bridge	Single USB-to-UART bridge chip provides transfer rates up to 3 Mbps.
RGB LED	Addressable RGB LED, driven by GPIO38.
3.3 V Power On LED	Turns on when the USB power is connected to the board.

**Note:** For boards with Octal SPI flash/PSRAM memory embedded ESP32-S3-WROOM-1/1U modules, and boards with ESP32-S3-WROOM-2 modules, the pins GPIO35, GPIO36 and GPIO37 are used for the internal communi-

cation between ESP32-S3 and SPI flash/PSRAM memory, thus not available for external use.

---

## Start Application Development

Before powering up your board, please make sure that it is in good condition with no obvious signs of damage.

## Required Hardware

- ESP32-S3-DevKitC-1
- USB 2.0 cable (Standard-A to Micro-B)
- Computer running Windows, Linux, or macOS

---

**Note:** Be sure to use an appropriate USB cable. Some cables are for charging only and do not provide the needed data lines nor work for programming the boards.

---

**Hardware Setup** Connect the board with the computer using **USB-to-UART Port** or **ESP32-S3 USB Port**. In subsequent steps, **USB-to-UART Port** will be used by default.

**Software Setup** Please proceed to [Get Started](#), where Section [Installation](#) will quickly help you set up the development environment and then flash an application example onto your board.

## Contents and Packaging

**Ordering Information** The development board has a variety of variants to choose from, as shown in the table below.

Ordering Code	Module Integrated	Flash	PSRAM	SPI	Voltage
ESP32-S3-DevKitC-1-N8R8	ESP32-S3-WROOM-1-N8R8	8 MB QD	8 MB OT	3.3 V	
ESP32-S3-DevKitC-1-N32R16V	ESP32-S3-WROOM-2-N32R16V	32 MB OT	16 MB OT	1.8 V	
ESP32-S3-DevKitC-1U-N8R8	ESP32-S3-WROOM-1U-N8R8	8 MB QD	8 MB OT	3.3 V	

---

**Note:** In the table above, QD stands for Quad SPI and OT stands for Octal SPI.

---

**Retail Orders** If you order a few samples, each board comes in an individual package in either antistatic bag or any packaging depending on your retailer.

For retail orders, please go to <https://www.espressif.com/en/contact-us/get-samples>.

**Wholesale Orders** If you order in bulk, the boards come in large cardboard boxes.

For wholesale orders, please go to <https://www.espressif.com/en/contact-us/sales-questions>.

## 1.1.2 Hardware Reference

### Block Diagram

The block diagram below shows the components of ESP32-S3-DevKitC-1 and their interconnections.

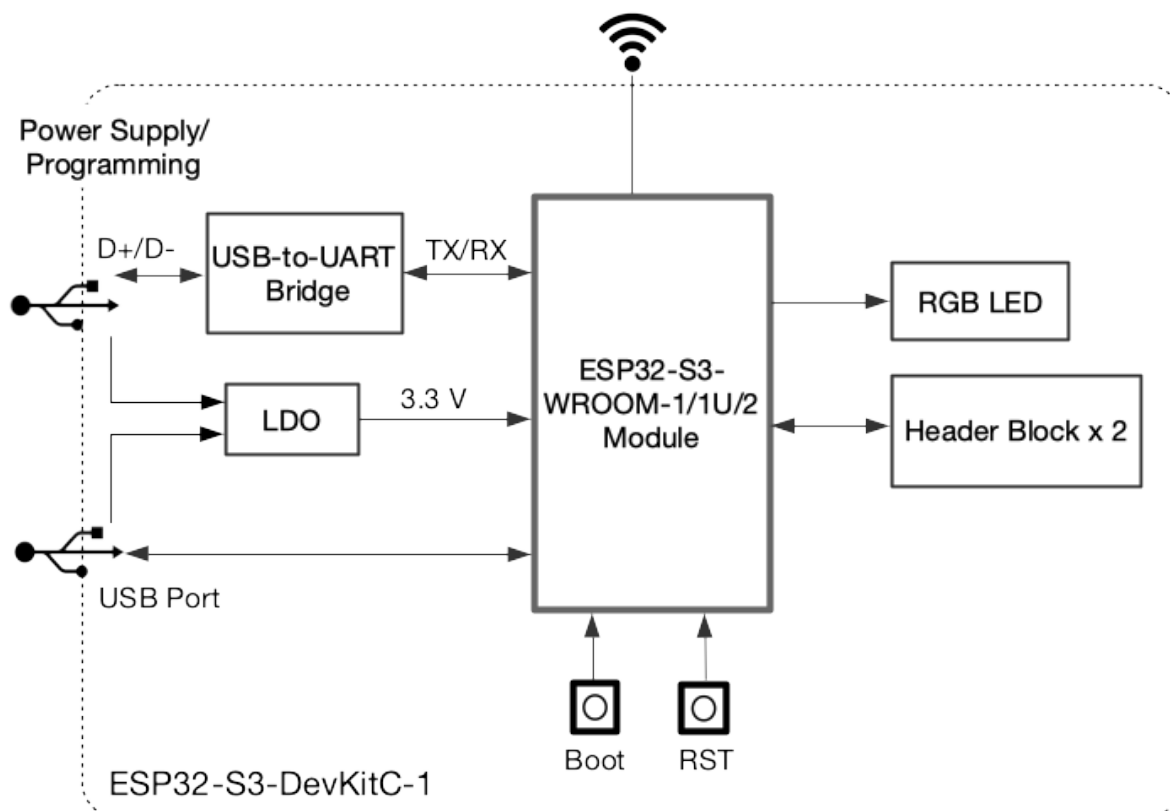

Fig. 3: ESP32-S3-DevKitC-1 (click to enlarge)

**Power Supply Options** There are three mutually exclusive ways to provide power to the board:

- USB-to-UART Port and ESP32-S3 USB Port (either one or both), default power supply (recommended)
- 5V and G (GND) pins
- 3V3 and G (GND) pins

### Header Block

The two tables below provide the **Name** and **Function** of the pins on both sides of the board (J1 and J3). The pin names are shown in [ESP32-S3-DevKitC-1 - front](#). The numbering is the same as in the [Board Schematic](#) (PDF).

## J1

No.	Name	Type <sup>Page 7, 1</sup>	Function
1	3V3	P	3.3 V power supply
2	3V3	P	3.3 V power supply
3	RST	I	EN
4	4	I/O/T	RTC_GPIO4, GPIO4, TOUCH4, ADC1_CH3
5	5	I/O/T	RTC_GPIO5, GPIO5, TOUCH5, ADC1_CH4
6	6	I/O/T	RTC_GPIO6, GPIO6, TOUCH6, ADC1_CH5
7	7	I/O/T	RTC_GPIO7, GPIO7, TOUCH7, ADC1_CH6
8	15	I/O/T	RTC_GPIO15, GPIO15, U0RTS, ADC2_CH4, XTAL_32K_P
9	16	I/O/T	RTC_GPIO16, GPIO16, U0CTS, ADC2_CH5, XTAL_32K_N
10	17	I/O/T	RTC_GPIO17, GPIO17, U1TXD, ADC2_CH6
11	18	I/O/T	RTC_GPIO18, GPIO18, U1RXD, ADC2_CH7, CLK_OUT3
12	8	I/O/T	RTC_GPIO8, GPIO8, TOUCH8, ADC1_CH7, SUBSPICS1
13	3	I/O/T	RTC_GPIO3, GPIO3, TOUCH3, ADC1_CH2
14	46	I/O/T	GPIO46
15	9	I/O/T	RTC_GPIO9, GPIO9, TOUCH9, ADC1_CH8, FSPIHD, SUBSPIHD
16	10	I/O/T	RTC_GPIO10, GPIO10, TOUCH10, ADC1_CH9, FSPICS0, FSPIIO4, SUBSPICS0
17	11	I/O/T	RTC_GPIO11, GPIO11, TOUCH11, ADC2_CH0, FSPID, FSPIIO5, SUBSPID
18	12	I/O/T	RTC_GPIO12, GPIO12, TOUCH12, ADC2_CH1, FSPICLK, FSPIIO6, SUBSPICLK
19	13	I/O/T	RTC_GPIO13, GPIO13, TOUCH13, ADC2_CH2, FSPIQ, FSPIIO7, SUBSPIQ
20	14	I/O/T	RTC_GPIO14, GPIO14, TOUCH14, ADC2_CH3, FSPIWP, FSPIDQS, SUBSPIWP
21	5V	P	5 V power supply
22	G	G	Ground

## J3

No.	Name	Type	Function
1	G	G	Ground
2	TX	I/O/T	U0TXD, GPIO43, CLK_OUT1
3	RX	I/O/T	U0RXD, GPIO44, CLK_OUT2
4	1	I/O/T	RTC_GPIO1, GPIO1, TOUCH1, ADC1_CH0
5	2	I/O/T	RTC_GPIO2, GPIO2, TOUCH2, ADC1_CH1
6	42	I/O/T	MTMS, GPIO42
7	41	I/O/T	MTDI, GPIO41, CLK_OUT1
8	40	I/O/T	MTDO, GPIO40, CLK_OUT2
9	39	I/O/T	MTCK, GPIO39, CLK_OUT3, SUBSPICS1
10	38	I/O/T	GPIO38, FSPIWP, SUBSPIWP, RGB LED
11	37	I/O/T	SPIDQS, GPIO37, FSPIQ, SUBSPIQ
12	36	I/O/T	SPIIO7, GPIO36, FSPICLK, SUBSPICLK
13	35	I/O/T	SPIIO6, GPIO35, FSPID, SUBSPID
14	0	I/O/T	RTC_GPIO0, GPIO0
15	45	I/O/T	GPIO45
16	48	I/O/T	GPIO48, SPICLK_N, SUBSPICLK_N_DIFF
17	47	I/O/T	GPIO47, SPICLK_P, SUBSPICLK_P_DIFF
18	21	I/O/T	RTC_GPIO21, GPIO21
19	20	I/O/T	RTC_GPIO20, GPIO20, U1CTS, ADC2_CH9, CLK_OUT1, USB_D+
20	19	I/O/T	RTC_GPIO19, GPIO19, U1RTS, ADC2_CH8, CLK_OUT2, USB_D-
21	G	G	Ground
22	G	G	Ground

<sup>1</sup> P: Power supply; I: Input; O: Output; T: High impedance.

For description of function names, please refer to [ESP32-S3 Series Datasheet \(PDF\)](#).

## ESP32-S3-DevKitC-1

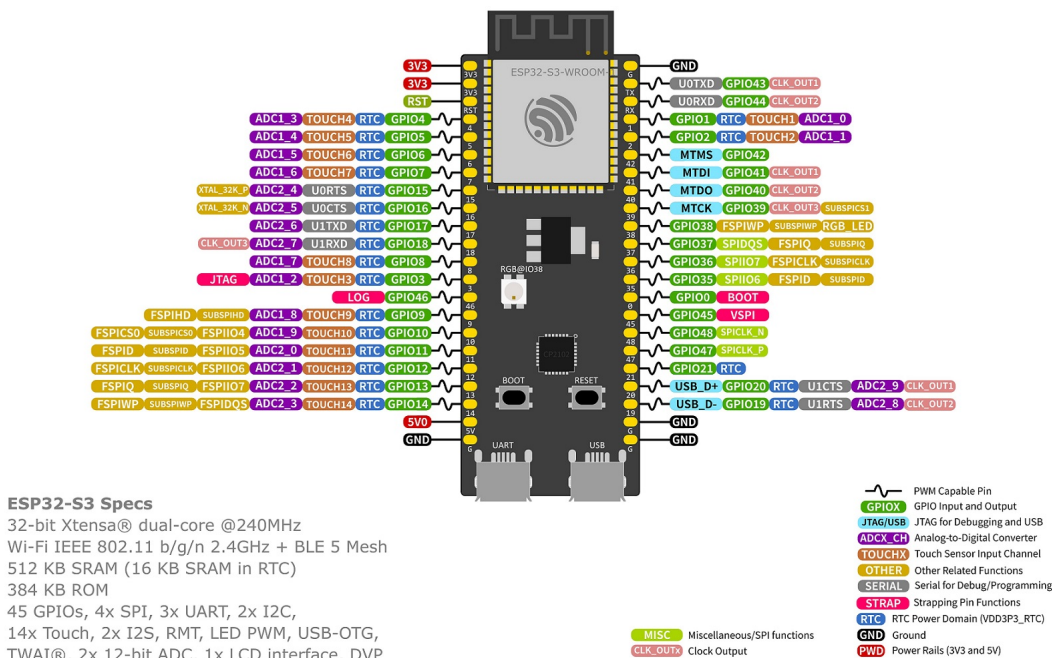

Fig. 4: ESP32-S3-DevKitC-1 Pin Layout (click to enlarge)

### Pin Layout

### 1.1.3 Hardware Revision Details

#### Initial release

**Note:** Both the initial and v1.1 versions of ESP32-S3-DevKitC-1 are available on the market. The main difference lies in the GPIO assignment for the RGB LED: the initial version uses GPIO48, whereas v1.1 uses GPIO38.

### 1.1.4 Related Documents

- [ESP32-S3 Datasheet \(PDF\)](#)
- [ESP32-S3-WROOM-1 & ESP32-S3-WROOM-1U Datasheet \(PDF\)](#)
- [ESP32-S3-WROOM-2 Datasheet \(PDF\)](#)
- [ESP32-S3-DevKitC-1 Schematic \(PDF\)](#)
- [ESP32-S3-DevKitC-1 PCB layout \(PDF\)](#)
- [ESP32-S3-DevKitC-1 Dimensions \(PDF\)](#)
- [ESP32-S3-DevKitC-1 Dimensions source file \(DXF\)](#) - You can view it with [Autodesk Viewer](#) online

For further design documentation for the board, please contact us at [sales@espressif.com](mailto:sales@espressif.com).

### ESP32-S3-DevKitC-1 v1.0

The latest version: [ESP32-S3-DevKitC-1 v1.1](#)

This user guide will help you get started with ESP32-S3-DevKitC-1 and will also provide more in-depth information.

The ESP32-S3-DevKitC-1 is an entry-level development board equipped with ESP32-S3-WROOM-1, ESP32-S3-WROOM-1U, or ESP32-S3-WROOM-2, a general-purpose Wi-Fi + Bluetooth® Low Energy MCU module that integrates complete Wi-Fi and Bluetooth Low Energy functions.

Most of the I/O pins on the module are broken out to the pin headers on both sides of this board for easy interfacing. Developers can either connect peripherals with jumper wires or mount ESP32-S3-DevKitC-1 on a breadboard.

Fig. 5: ESP32-S3-DevKitC-1 with ESP32-S3-WROOM-1 Module

The document consists of the following major sections:

- *Getting started*: Overview of the board and hardware/software setup instructions to get started.
- *Hardware Reference*: More detailed information about the board's hardware.
- *Hardware Revision Details*: Revision history, known issues, and links to user guides for previous versions (if any) of the board.
- *Related Documents*: Links to related documentation.

**Getting Started** This section provides a brief introduction of ESP32-S3-DevKitC-1, instructions on how to do the initial hardware setup and how to flash firmware onto it.

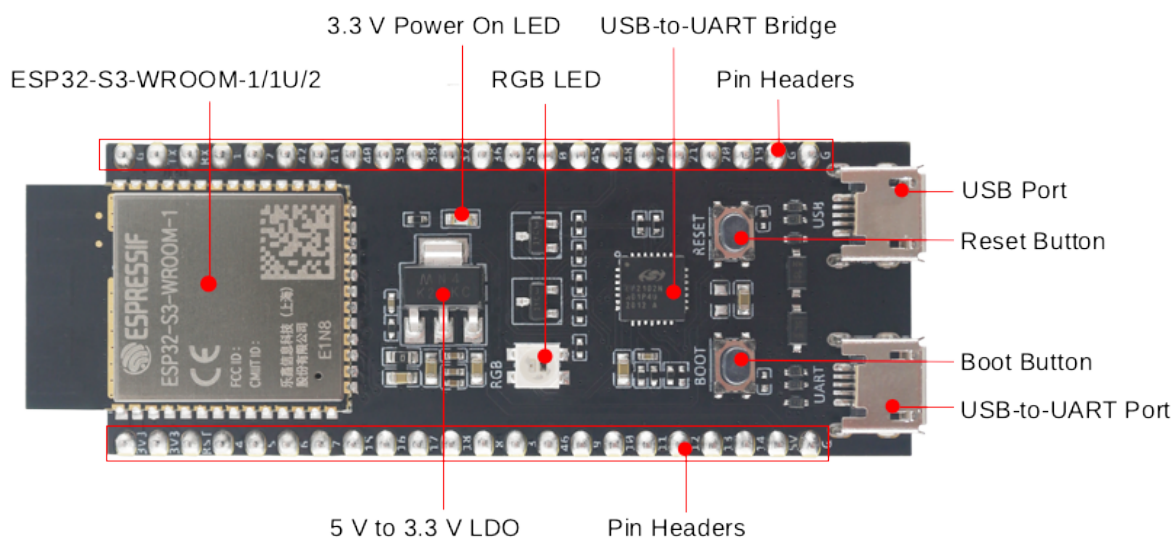

Fig. 6: ESP32-S3-DevKitC-1 - front

**Description of Components** The key components of the board are described in a counter-clockwise direction.

Key Component	Description
ESP32-S3-WROOM-1/1U/2	ESP32-S3-WROOM-1, ESP32-S3-WROOM-1U, and ESP32-S3-WROOM-2 are powerful, generic Wi-Fi + Bluetooth Low Energy MCU modules that have a rich set of peripherals. They provide acceleration for neural network computing and signal processing workloads. ESP32-S3-WROOM-1 and ESP32-S3-WROOM-2 comes with a PCB antenna. ESP32-S3-WROOM-1U comes with an external antenna connector.
5 V to 3.3 V LDO	Power regulator that converts a 5 V supply into a 3.3 V output.
Pin Headers	All available GPIO pins (except for the SPI bus for flash) are broken out to the pin headers on the board for easy interfacing and programming. For details, please see <a href="#">Header Block</a> .
USB-to-UART Port	A Micro-USB port used for power supply to the board, for flashing applications to the chip, as well as for communication with the chip via the on-board USB-to-UART bridge.
Boot Button	Download button. Holding down <b>Boot</b> and then pressing <b>Reset</b> initiates Firmware Download mode for downloading firmware through the serial port.
Reset Button	Press this button to restart the system.
ESP32-S3 USB Port	ESP32-S3 full-speed USB OTG interface, compliant with the USB 1.1 specification. The interface is used for power supply to the board, for flashing applications to the chip, for communication with the chip using USB 1.1 protocols, as well as for JTAG debugging.
USB-to-UART Bridge	Single USB-to-UART bridge chip provides transfer rates up to 3 Mbps.
RGB LED	Addressable RGB LED, driven by GPIO48.
3.3 V Power On LED	Turns on when the USB power is connected to the board.

---

**Note:** For boards with Octal SPI flash/PSRAM memory embedded ESP32-S3-WROOM-1/1U modules, and boards with ESP32-S3-WROOM-2 modules, the pins GPIO35, GPIO36 and GPIO37 are used for the internal communication between ESP32-S3 and SPI flash/PSRAM memory, thus not available for external use.

---

**Start Application Development** Before powering up your board, please make sure that it is in good condition with no obvious signs of damage.

### Required Hardware

- ESP32-S3-DevKitC-1
- USB 2.0 cable (Standard-A to Micro-B)
- Computer running Windows, Linux, or macOS

---

**Note:** Be sure to use an appropriate USB cable. Some cables are for charging only and do not provide the needed data lines nor work for programming the boards.

---

**Hardware Setup** Connect the board with the computer using **USB-to-UART Port**. Connection using **ESP32-S3 USB Port** is not fully implemented in software. In subsequent steps, **USB-to-UART Port** will be used by default.

**Software Setup** Please proceed to [Get Started](#), where Section [Installation](#) will quickly help you set up the development environment and then flash an application example onto your board.

### Contents and Packaging

**Ordering Information** The development board has a variety of variants to choose from, as shown in the table below.

Ordering Code	Module Integrated	Flash	PSRAM	SPI Voltage
ESP32-S3-DevKitC-1-N8R8	ESP32-S3-WROOM-1-N8R8	8 MB QD	8 MB OT	3.3 V
ESP32-S3-DevKitC-1-N32R16V	ESP32-S3-WROOM-2-N32R16V	32 MB OT	16 MB OT	1.8 V
ESP32-S3-DevKitC-1U-N8R8	ESP32-S3-WROOM-1U-N8R8	8 MB QD	8 MB OT	3.3 V

---

**Note:** In the table above, QD stands for Quad SPI and OT stands for Octal SPI.

---

**Retail Orders** If you order a few samples, each board comes in an individual package in either antistatic bag or any packaging depending on your retailer.

For retail orders, please go to <https://www.espressif.com/en/company/contact/buy-a-sample>.

**Wholesale Orders** If you order in bulk, the boards come in large cardboard boxes.

For wholesale orders, please go to <https://www.espressif.com/en/contact-us/sales-questions>.

## Hardware Reference

**Block Diagram** The block diagram below shows the components of ESP32-S3-DevKitC-1 and their interconnections.

**Power Supply Options** There are three mutually exclusive ways to provide power to the board:

- USB-to-UART Port and ESP32-S3 USB Port (either one or both), default power supply (recommended)
- 5V and G (GND) pins
- 3V3 and G (GND) pins

**Header Block** The two tables below provide the **Name** and **Function** of the pins on both sides of the board (J1 and J3). The pin names are shown in *ESP32-S3-DevKitC-1 - front*. The numbering is the same as in the [Board Schematic \(PDF\)](#).

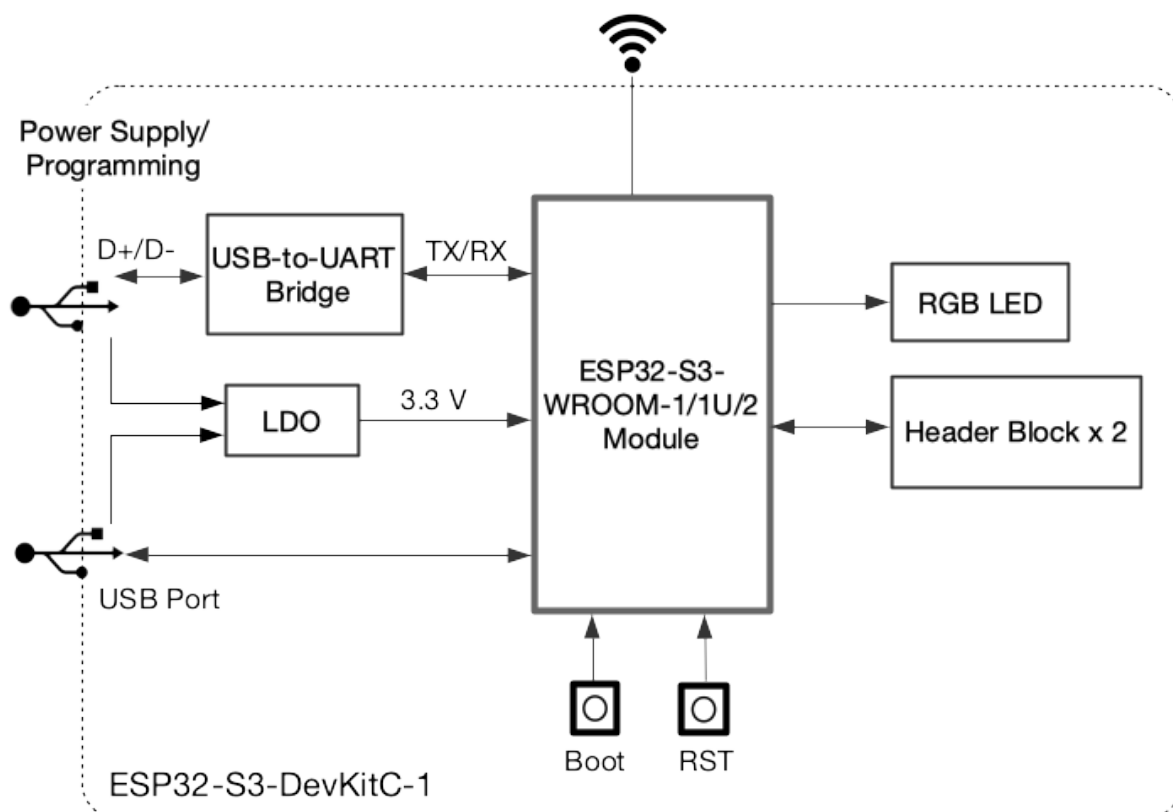

Fig. 7: ESP32-S3-DevKitC-1 (click to enlarge)

## J1

No.	Name	Type	Function
1	3V3	P	3.3 V power supply
2	3V3	P	3.3 V power supply
3	RST	I	EN
4	4	I/O/T	RTC_GPIO4, GPIO4, TOUCH4, ADC1_CH3
5	5	I/O/T	RTC_GPIO5, GPIO5, TOUCH5, ADC1_CH4
6	6	I/O/T	RTC_GPIO6, GPIO6, TOUCH6, ADC1_CH5
7	7	I/O/T	RTC_GPIO7, GPIO7, TOUCH7, ADC1_CH6
8	15	I/O/T	RTC_GPIO15, GPIO15, U0RTS, ADC2_CH4, XTAL_32K_P
9	16	I/O/T	RTC_GPIO16, GPIO16, U0CTS, ADC2_CH5, XTAL_32K_N
10	17	I/O/T	RTC_GPIO17, GPIO17, U1TXD, ADC2_CH6
11	18	I/O/T	RTC_GPIO18, GPIO18, U1RXD, ADC2_CH7, CLK_OUT3
12	8	I/O/T	RTC_GPIO8, GPIO8, TOUCH8, ADC1_CH7, SUBSPICS1
13	3	I/O/T	RTC_GPIO3, GPIO3, TOUCH3, ADC1_CH2
14	46	I/O/T	GPIO46
15	9	I/O/T	RTC_GPIO9, GPIO9, TOUCH9, ADC1_CH8, FSPiHD, SUBSPiHD
16	10	I/O/T	RTC_GPIO10, GPIO10, TOUCH10, ADC1_CH9, FSPiCS0, FSPiIO4, SUBSPiCS0
17	11	I/O/T	RTC_GPIO11, GPIO11, TOUCH11, ADC2_CH0, FSPiD, FSPiIO5, SUBSPiD
18	12	I/O/T	RTC_GPIO12, GPIO12, TOUCH12, ADC2_CH1, FSPiCLK, FSPiIO6, SUBSPiCLK
19	13	I/O/T	RTC_GPIO13, GPIO13, TOUCH13, ADC2_CH2, FSPiQ, FSPiIO7, SUBSPiQ
20	14	I/O/T	RTC_GPIO14, GPIO14, TOUCH14, ADC2_CH3, FSPiWP, FSPiDQS, SUBSPiWP
21	5V	P	5 V power supply
22	G	G	Ground

J3

No.	Name	Type	Function
1	G	G	Ground
2	TX	I/O/T	U0TXD, GPIO43, CLK_OUT1
3	RX	I/O/T	U0RXD, GPIO44, CLK_OUT2
4	1	I/O/T	RTC_GPIO1, GPIO1, TOUCH1, ADC1_CH0
5	2	I/O/T	RTC_GPIO2, GPIO2, TOUCH2, ADC1_CH1
6	42	I/O/T	MTMS, GPIO42
7	41	I/O/T	MTDI, GPIO41, CLK_OUT1
8	40	I/O/T	MTDO, GPIO40, CLK_OUT2
9	39	I/O/T	MTCK, GPIO39, CLK_OUT3, SUBSPICS1
10	38	I/O/T	GPIO38, FSPIWP, SUBSPIWP
11	37	I/O/T	SPIDQS, GPIO37, FSPIQ, SUBSPIQ
12	36	I/O/T	SPIIO7, GPIO36, FSPICLK, SUBSPICLK
13	35	I/O/T	SPIIO6, GPIO35, FSPID, SUBSPID
14	0	I/O/T	RTC_GPIO0, GPIO0
15	45	I/O/T	GPIO45
16	48	I/O/T	GPIO48, SPICLK_N, SUBSPICLK_N_DIFF, RGB LED
17	47	I/O/T	GPIO47, SPICLK_P, SUBSPICLK_P_DIFF
18	21	I/O/T	RTC_GPIO21, GPIO21
19	20	I/O/T	RTC_GPIO20, GPIO20, U1CTS, ADC2_CH9, CLK_OUT1, USB_D+
20	19	I/O/T	RTC_GPIO19, GPIO19, U1RTS, ADC2_CH8, CLK_OUT2, USB_D-
21	G	G	Ground
22	G	G	Ground

For description of function names, please refer to [Chip Datasheet \(PDF\)](#).

## ESP32-S3-DevKitC-1

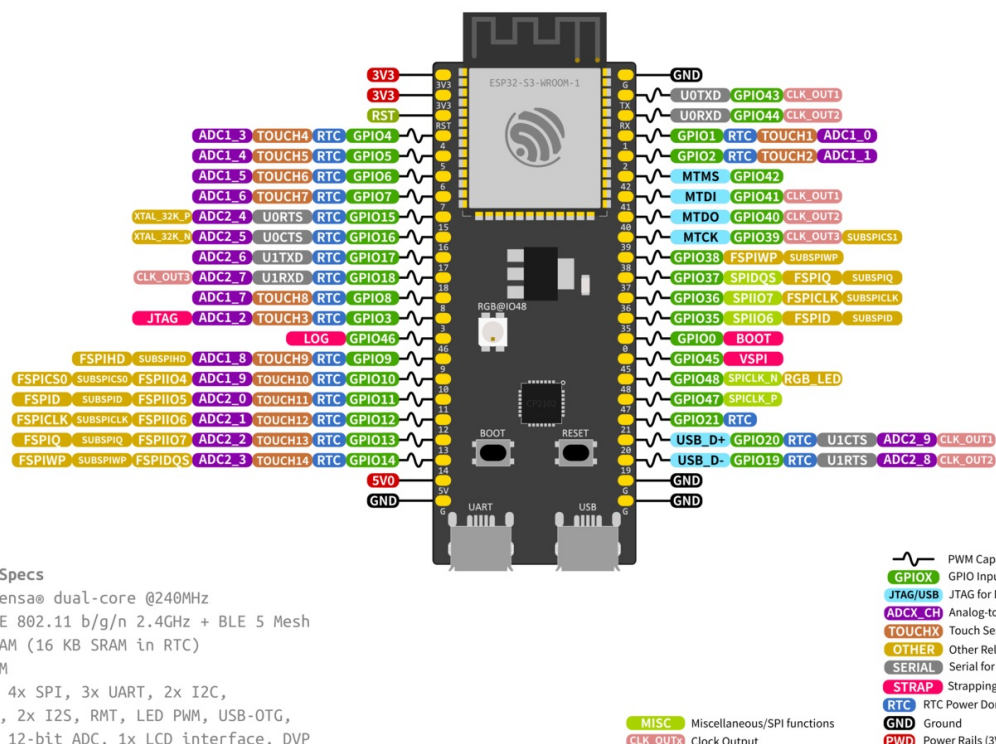

Fig. 8: ESP32-S3-DevKitC-1 Pin Layout (click to enlarge)

<sup>1</sup> P: Power supply; I: Input; O: Output; T: High impedance.

## Pin Layout

**Hardware Revision Details** This is the first revision of this board released.

## Related Documents

- [ESP32-S3 Datasheet \(PDF\)](#)
- [ESP32-S3-WROOM-1 & ESP32-S3-WROOM-1U Datasheet \(PDF\)](#)
- [ESP32-S3-WROOM-2 Datasheet \(PDF\)](#)
- [ESP32-S3-DevKitC-1 Schematic \(PDF\)](#)
- [ESP32-S3-DevKitC-1 PCB layout \(PDF\)](#)
- [ESP32-S3-DevKitC-1 Dimensions \(PDF\)](#)
- [ESP32-S3-DevKitC-1 Dimensions source file \(DXF\)](#) - You can view it with [Autodesk Viewer](#) online

For further design documentation for the board, please contact us at [sales@espressif.com](mailto:sales@espressif.com).

## Chapter 2

# ESP32-S3-USB-OTG

ESP32-S3-USB-OTG is a development board that focuses on USB-OTG function verification and application development.

Application examples for this board can be found at [Examples](#).

### 2.1 ESP32-S3-USB-OTG

ESP32-S3-USB-OTG is a development board that focuses on USB-OTG function verification and application development. It is based on ESP32-S3 SoC, supports Wi-Fi and BLE 5.0 wireless functions, and supports USB host and USB device functions. It can be used to develop applications such as wireless storage devices, Wi-Fi network cards, LTE MiFi, multimedia devices, virtual keyboards and mice. The development board has the following features:

- Onboard ESP32-S3-MINI-1-N8 module, with built-in 8 MB flash
- Onboard USB Type-A host and device interface, with built-in USB interface switching circuit
- Onboard USB to serial debugging chip (Micro USB interface)
- Onboard 1.3-inch LCD color screen, supports GUI
- Onboard SD card interface, compatible with SDIO and SPI interfaces
- Onboard charging IC, can be connected to lithium battery

**The document consists of the following major sections:**

- *Getting Started*: Provides a brief overview of ESP32-S3-USB-OTG and necessary hardware and software information.
- *Hardware Reference*: Provides detailed hardware information of ESP32-S3-USB-OTG.
- *Related Documents*: Provides links to related documents.

#### 2.1.1 Getting Started

This section describes how to start using ESP32-S3-USB-OTG. It includes introduction to basic information about ESP32-S3-USB-OTG first, and then on how to start using the development board for application development, as well as board packaging and retail information.

#### Description of Components

The ESP32-S3-USB-OTG development board includes the following parts:

- **Motherboard**: ESP32-S3-USB-OTG motherboard is the core of the kit. The motherboard integrates the ESP32-S3-MINI-1 module and provides an interface of the 1.3-inch LCD screen.

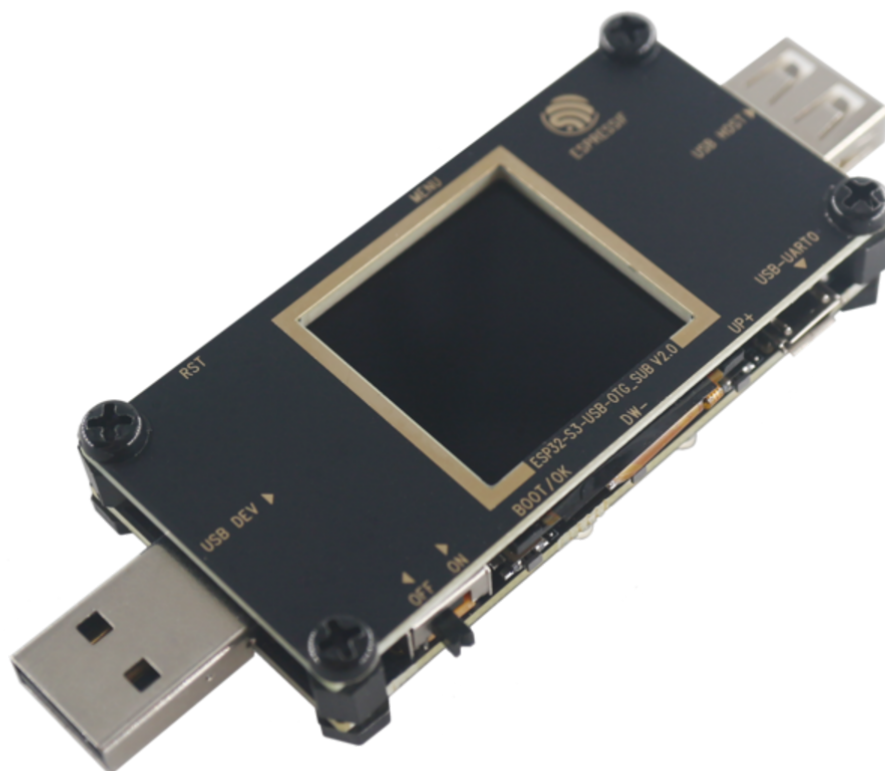

Fig. 1: ESP32-S3-USB-OTG (click to enlarge)

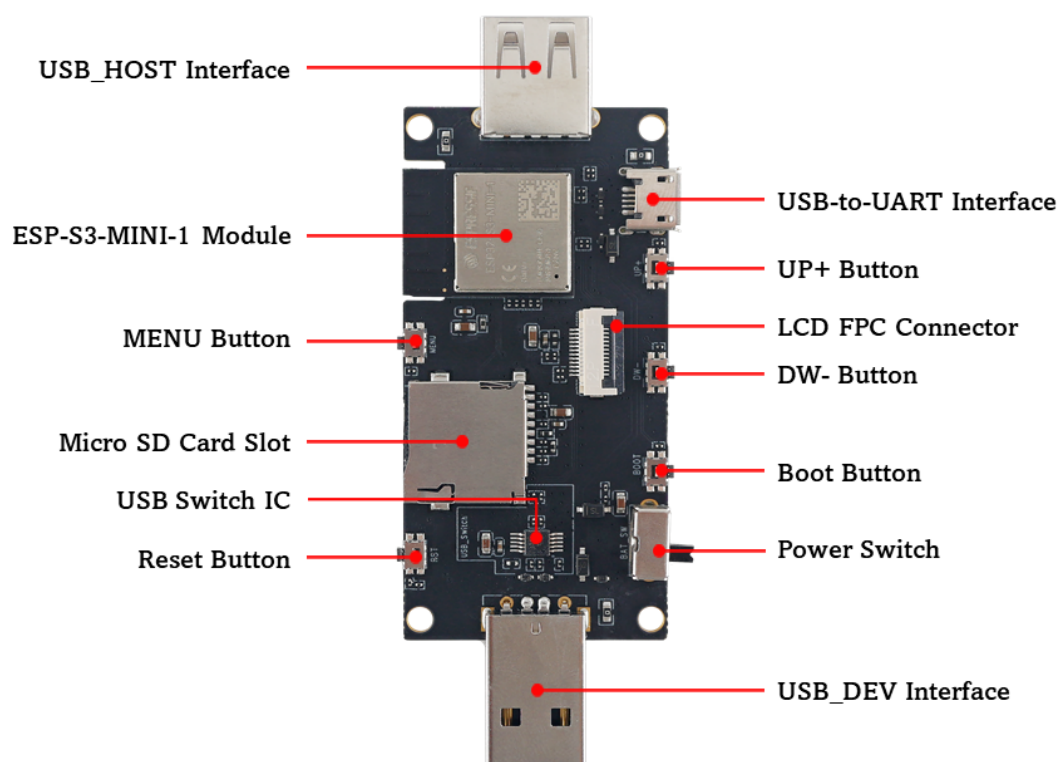

Fig. 2: ESP32-S3-USB-OTG Top View (click to enlarge)

The following table starts with the USB\_HOST Interface on the left, and introduces the main components in the above figure in an anticlockwise order.

Main components	Description
USB_HOST Interface	USB Type-A female port, used to connect other USB devices.
ESP32-S3-MINI-1 Module	ESP32-S3-MINI-1 is a powerful, generic Wi-Fi + Bluetooth LE MCU module that has a rich set of peripherals. It has strong ability for neural network computing and signal processing. ESP32-S3-MINI-1 comes with a PCB antenna and is pin-to-pin compatible with ESP32-S2-MINI-1.
MENU Button	Menu button.
Micro SD Card Slot	Micro SD card can be inserted. Both four-line SDIO and SPI mode are supported.
USB Switch IC	By setting the level of USB_SEL, you can switch USB peripherals to make them either connected to the USB_DEV interface or the USB_HOST interface. USB_DEV will be connected by default.
Reset Button	Press this button to restart the system.
USB_DEV Interface	USB Type-A male port, can be connected to the USB host, and also used as a lithium battery charge power source.
Power Switch	Switch to ON to use battery power. Switch to OFF to power off battery.
Boot Button	Download button. Holding down Boot and then pressing Reset initiates Firmware Download mode for downloading firmware through the serial port.
DW- Button	Down button.
LCD FPC Connector	Used to connect the 1.3-inch LCD screen.
UP+ Button	Up button.
USB-to-UART Interface	A Micro-USB port used for power supply to the board, for flashing applications to the chip, as well as for communication with the chip via the on-board USB-to-UART bridge.

The following table starts with the Yellow LED on the left, and introduces the main components in the above figure in an anticlockwise order.

Main components	Description
Yellow LED	Driven by GPIO16, set high level to turn on.
Green LED	Driven by GPIO15, set high level to turn on.
Charging LED	During charging, the red light is on, which will be turned off when charged.
Battery Solder Joints	3.6 V lithium battery can be welded to power the motherboard.
Charging Circuit	Used to charge lithium battery.
Free Pins	Idle pins that can be customized.
USB-to-UART Bridge	Single USB-to-UART bridge chip provides transfer rates up to 3 Mbps.

- **Subboard:** ESP32-S3-USB-OTG-SUB mount the 1.3-inch LCD screen

### Application Examples

The following application examples are available for ESP32-S3-USB-OTG:

- [factory](#) - Demonstrates a factory demo for the ESP32-S3-USB-OTG development board, providing a reference for building, flashing, and monitoring projects using ESP-IDF and ESP Launchpad.

For more examples and the latest updates, please refer to the [examples](#) folder.

To explore the application examples or to develop your own, please follow the steps outlined in the [Start Application Development](#) section.

### Start Application Development

Before powering on the ESP32-S3-USB-OTG, please make sure that the development board is intact.

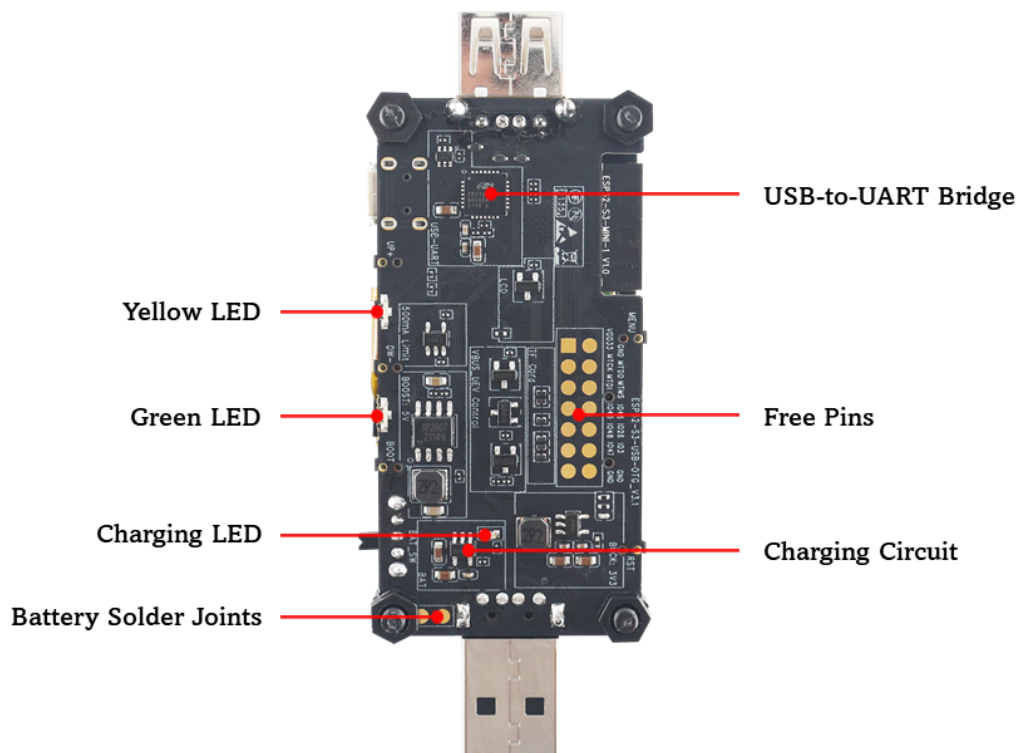

Fig. 3: ESP32-S3-USB-OTG Bottom View (click to enlarge)

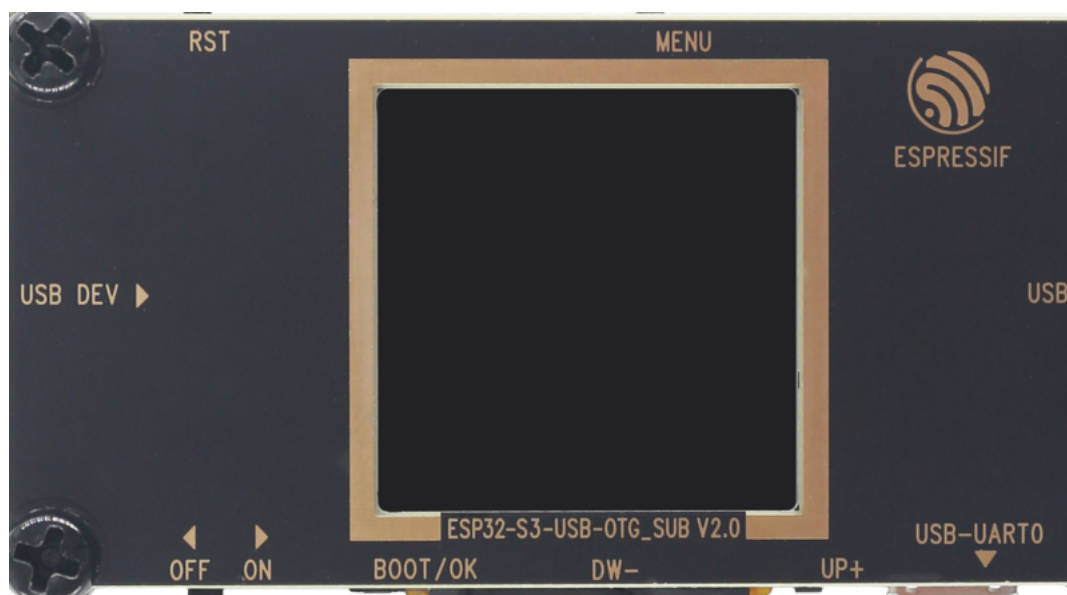

Fig. 4: ESP32-S3-USB-OTG Subboard (click to enlarge)

### Required Hardware

- ESP32-S3-USB-OTG
- A USB 2.0 data cable (standard A to Micro-B)
- Computer (Windows, Linux or macOS)

**Software Setup** Please proceed to [Get Started](#), where Section [Installation Step by Step](#) will quickly help you set up the development environment and then flash an application example onto your board.

### Contents and Packaging

**Retail Orders** If you order a few samples, each board comes in an individual package in either an antistatic bag or any packaging depending on your retailer.



Fig. 5: ESP32-S3-USB-OTG Package (click to enlarge)

Which contains the following parts:

- Motherboard:
  - ESP32-S3-USB-OTG
- Subboard:
  - ESP32-S3-USB-OTG\_SUB
- Fastener
  - Mounting bolt (x4)
  - Screw (x4)
  - Nut (x4)

For retail orders, please go to <https://www.espressif.com/zh-hans/company/contact/buy-a-sample>.

**Wholesale Order** If purchased in bulk, the development board will be packaged in a large cardboard box.

For wholesale orders, please go to <https://www.espressif.com/en/contact-us/sales-questions>.

## 2.1.2 Hardware Reference

### Block Diagram

The block diagram below shows the components of ESP32-S3-USB-OTG and their interconnections.

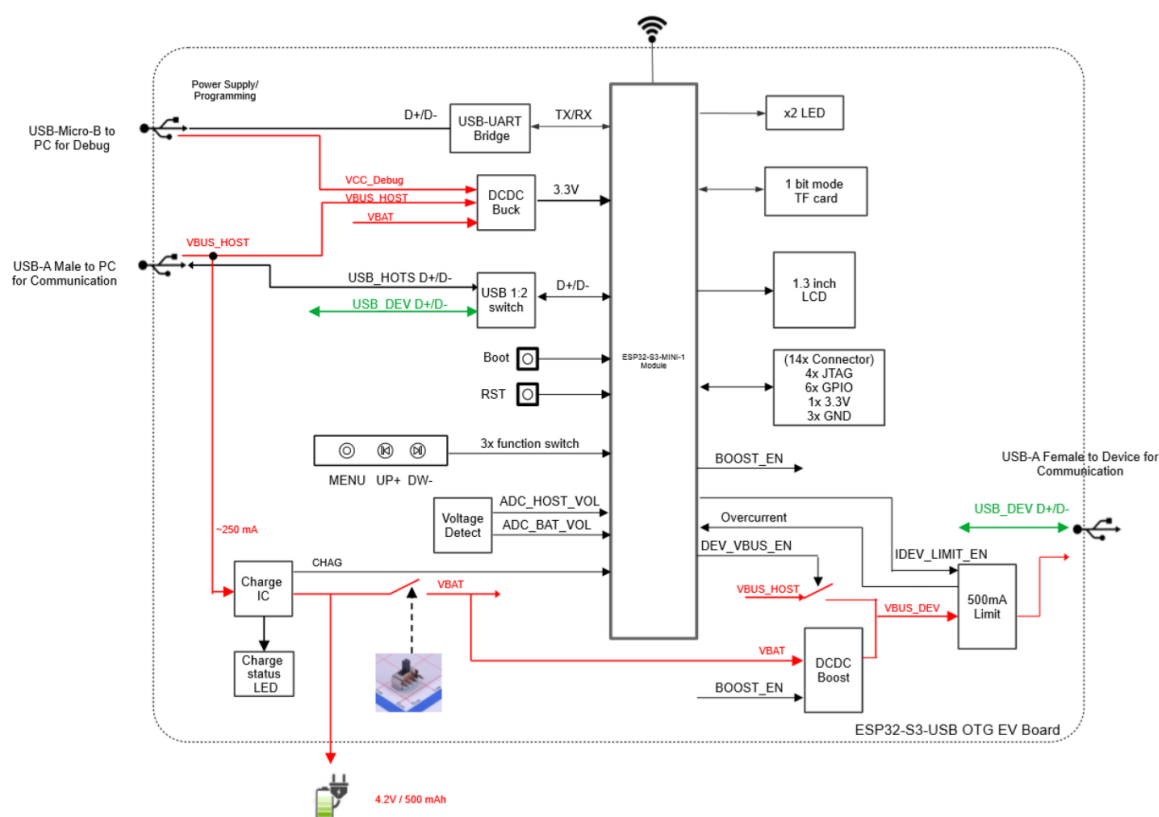

Fig. 6: ESP32-S3-USB-OTG Block Diagram (click to enlarge)

Please note that the external interface corresponding to the USB\_HOST D+ D- signal in the functional block diagram is USB\_DEV, which means that ESP32-S3 is used as a device to receive signals from other USB hosts. The external interface corresponding to the USB\_DEV D+ D- signal is USB\_HOST, which means that ESP32-S3 acts as a host to control other devices.

### Power Supply Options

There are three power supply methods for the development board:

1. Power supply through the `Micro_USB` interface
  - Use the USB cable (standard A to Micro-B) to connect the motherboard to a power supply device, and set battery switch to OFF. Please note that in this power supply mode, only the motherboard and display are powered.
2. Power supply through the `USB_DEV` interface
  - Set `DEV_VBUS_EN` to high level, and set the battery switch to OFF. This mode can supply power to the `USB_HOST` interface. The lithium battery will be charged at the same time (if the lithium battery is installed)
3. Power supply through the battery

- Set `BOOST_EN` to high level, and set the battery switch to ON. You should solder a 1-Serial lithium battery (3.7 V ~ 4.2 V) to the power solder joint reserved on the back of the motherboard first. This mode can supply power to the USB HOST interface at the same time. The battery interface description is as follows:



Fig. 7: Battery Connection (click to enlarge)

### USB HOST Interface Power Options

The USB HOST interface (Type-A female port) can supply power to the connected USB device. The power supply voltage is 5 V and the maximum current is 500 mA.

- There are two power supply methods for the USB HOST interface:
  1. Power is supplied through the USB\_DEV interface, and the 5 V power is directly from the power source connected to the interface.
  2. Power is supplied through the lithium battery, and the 3.6 V ~ 4.2 V voltage of the lithium battery is boosted to 5 V through the Boost circuit. The working status of Boost IC can be controlled by `BOOST_EN/GPIO13`, set high to enable Boost.
- USB HOST interface power supply selection:

BOOST_EN	DEV_VBUS_EN	Power Source
0	1	USB_DEV
1	0	Battery
0	0	No output
1	1	Undefined

- 500 mA current limiting circuit:

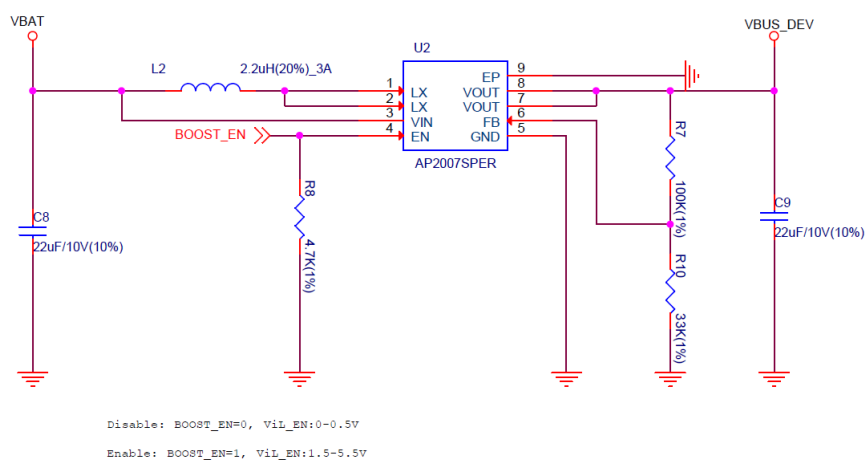
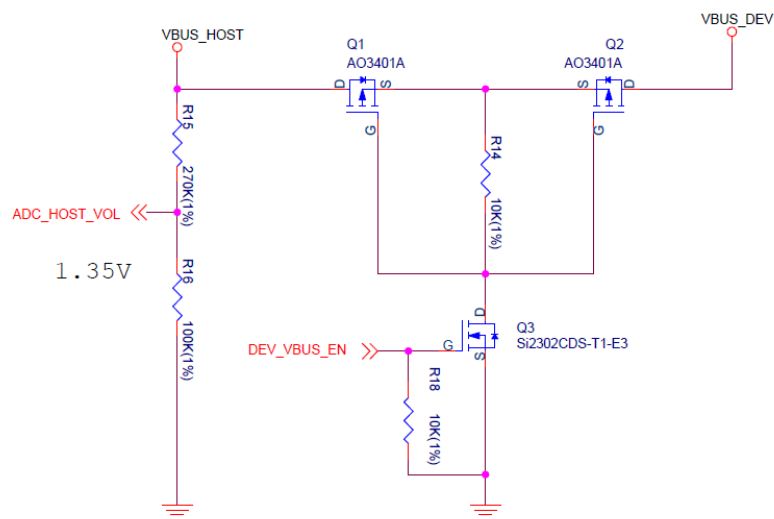

Fig. 8: Boost Circuit (click to enlarge)



Switch to VBUS\_HOST power mode: Step1: set BOOST\_EN=0 & Step2: set DEV\_VBUS\_EN=1  
 Switch to VBAT boost power mode: Step1: set DEV\_VBUS\_EN=0 & Step2: set BOOST\_EN=1

Fig. 9: Power Switch Circuit (click to enlarge)

1. The current limiting IC MIC2005A can limit the maximum output current of the USB HOST interface to 500 mA. Please set the IDEV\_LIMIT\_EN (GPIO17) to high level to enable the current-limiting IC to output voltage.

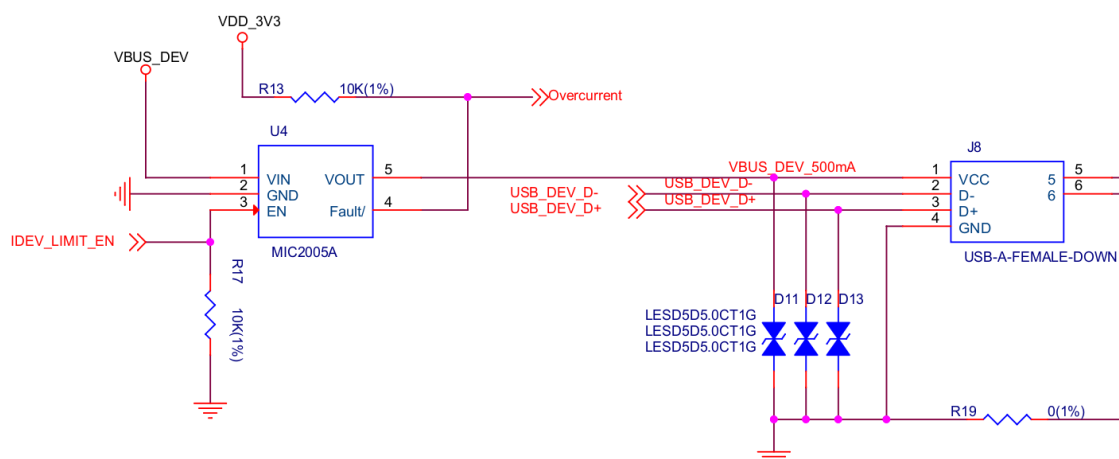

Fig. 10: 500 mA Current Limiting Circuit (click to enlarge)

### USB Interface Switch Circuit

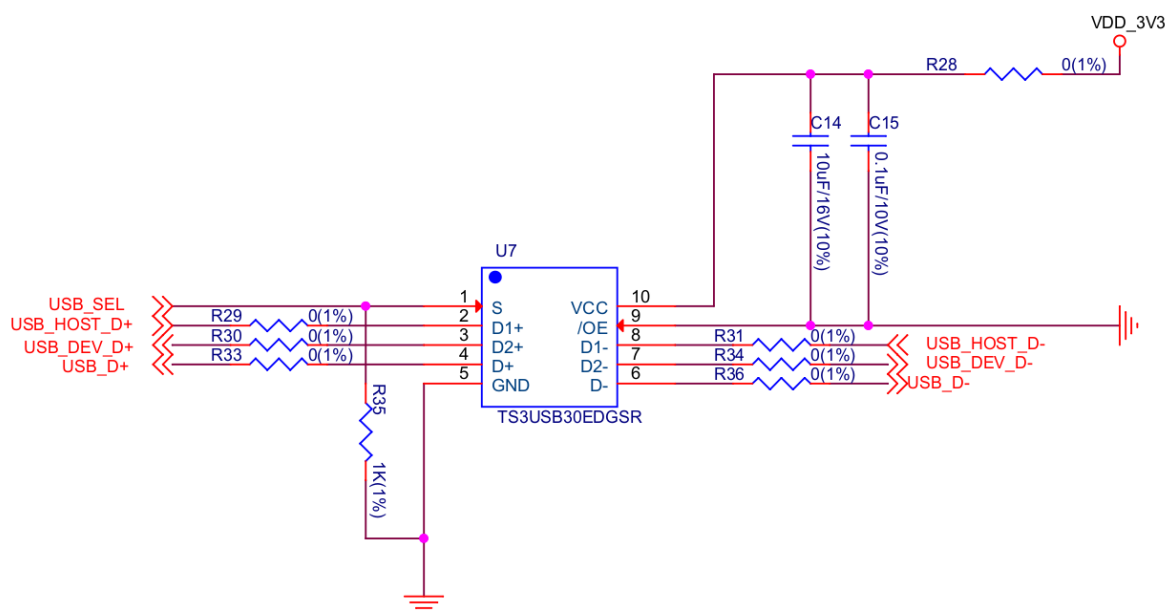

Fig. 11: USB Interface Switch Circuit (click to enlarge)

- When **USB\_SEL** (GPIO18) is set to high level, the USB D+/D- Pin (GPIO19, 20) will be connected to USB\_DEV D+ D-. Then you can use the USB HOST interface (Type-A female Port) to connect other USB devices.
- When **USB\_SEL** (GPIO18) is set to low level, the USB D+/D- Pin (GPIO19, 20) will be connected to USB\_HOST D+ D-. Then you can use the USB DEV interface (Type-A male port) to connect to a host like a PC.
- **USB\_SEL** is pulled low level by default.



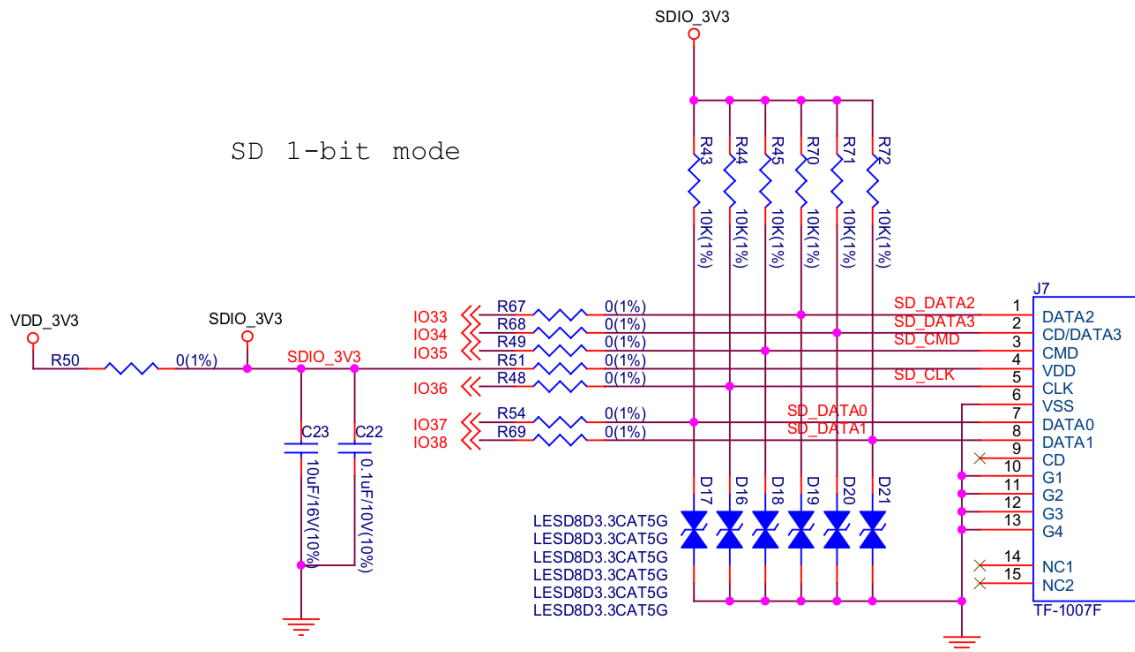

Fig. 13: SD Card Interface Circuit (click to enlarge)

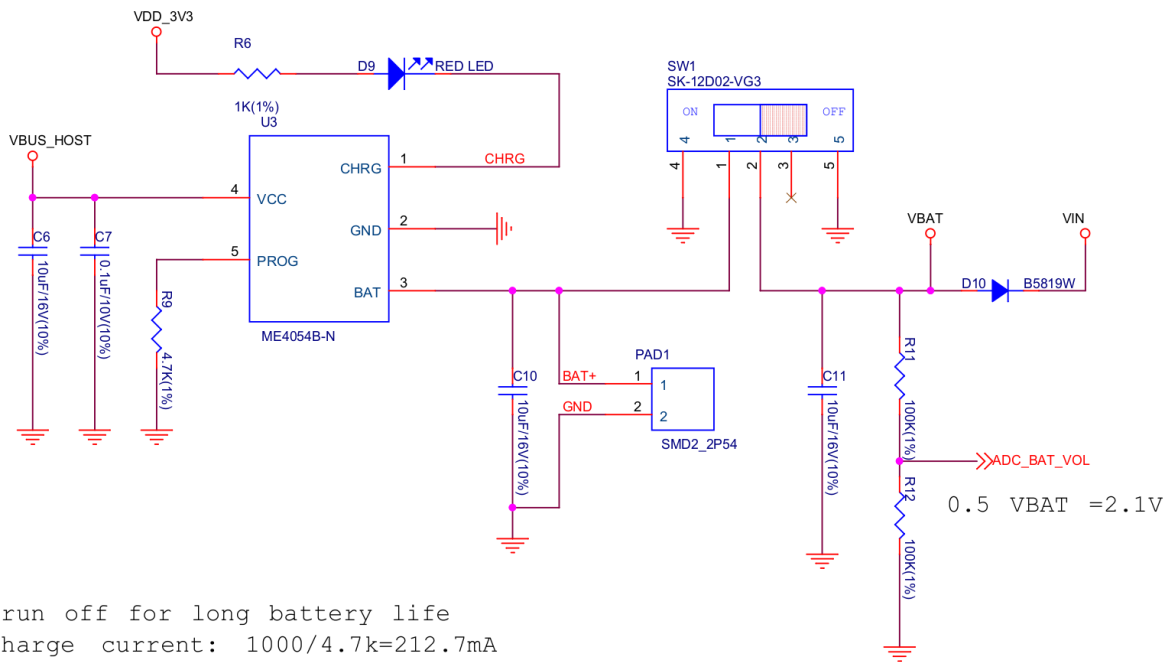

Fig. 14: Charging Circuit (click to enlarge)

No.	ESP32-S3-MINI-1 Pin	Description
1	GPIO18	USB_SEL: Used to switch the USB interface. When high level, the USB_HOST interface is enabled. When low level (default), the USB_DEV interface is enabled.
2	GPIO19	Connect with USB D-.
3	GPIO20	Connect with USB D+.
4	GPIO15	LED_GREEN: the light is lit when set high level.
5	GPIO16	LED_YELLOW: the light is lit when set high level.
6	GPIO0	BUTTON_OK: OK button, low level when pressed.
7	GPIO11	BUTTON_DW: Down button, low level when pressed.
8	GPIO10	BUTTON_UP: UP button, low level when pressed.
9	GPIO14	BUTTON_MENU: Menu button, low level when pressed.
10	GPIO8	LCD_RET: used to reset LCD, low level to reset.
11	GPIO5	LCD_EN: used to enable LCD, low level to enable.
12	GPIO4	LCD_DC: Used to switch data and command status.
13	GPIO6	LCD_SCLK: LCD SPI Clock.
14	GPIO7	LCD_SDA: LCD SPI MOSI.
15	GPIO9	LCD_BL: LCD backlight control.
16	GPIO36	SD_SCK: SD SPI CLK / SDIO CLK.
17	GPIO37	SD_DO: SD SPI MISO / SDIO Data0.
18	GPIO38	SD_D1: SDIO Data1.
19	GPIO33	SD_D2: SDIO Data2.
20	GPIO34	SD_D3: SD SPI CS / SDIO Data3.
21	GPIO1	HOST_VOL: USB_DEV voltage monitoring, ADC1 channel 0.
22	GPIO2	BAT_VOL: Battery voltage monitoring, ADC1 channel 1.
23	GPIO17	LIMIT_EN: Enable current limiting IC, high level enable.
24	GPIO21	OVER_CURRENT: Current overrun signal, high level means overrun.
25	GPIO12	DEV_VBUS_EN: High level to enable DEV_VBUS power supply.
26	GPIO13	BOOST_EN: High level to enable Boost boost circuit.

#### Extended pin:

No.	ESP32-S3-MINI-1 Pin	Description
1	GPIO45	FREE_1: Idle, can be customized.
2	GPIO46	FREE_2: Idle, can be customized.
3	GPIO48	FREE_3: Idle, can be customized.
4	GPIO26	FREE_4: Idle, can be customized.
5	GPIO47	FREE_5: Idle, can be customized.
6	GPIO3	FREE_6: Idle, can be customized.

### 2.1.3 Related Documents

Please download the following documents from [the HTML version of esp-dev-kits Documentation](#).

- [ESP32-S3 Datasheet \(PDF\)](#)
- [ESP32-S3-MINI-1/1U Datasheet \(PDF\)](#)
- [Espressif Product Selection Tool](#)
- [ESP32-S3-USB-OTG Schematic Diagram \(PDF\)](#)
- [ESP32-S3-USB-OTG PCB Layout Drawing \(PDF\)](#)
- [ST7789VW Datasheet \(PDF\)](#)



## Chapter 3

# ESP32-S3-LCD-EV-Board

ESP32-S3-LCD-EV-Board is a development board for evaluating and verifying esp32s3 screen interactive applications. It has the functions of touchscreen interaction and voice interaction.

---

**Note:** Please check the version number of your ESP32-S3-LCD-EV-Board-MB indicated by the silk marking on the back. For boards of the v1.5 version, please refer to [ESP32-S3-LCD-EV-Board v1.5](#). For boards of the v1.4 and below versions, please refer to [ESP32-S3-LCD-EV-Board v1.4](#).

Unless otherwise stated, the ESP32-S3-LCD-EV-Board in this document refers to both **ESP32-S3-LCD-EV-Board** and **ESP32-S3-LCD-EV-Board-2**.

---

### 3.1 ESP32-S3-LCD-EV-Board v1.5

---

**Note:** Please check the version number of your ESP32-S3-LCD-EV-Board-MB indicated by the silk marking on the back. For boards of the v1.5 version, please refer to this user guide. For boards of the v1.4 and below versions, please refer to [ESP32-S3-LCD-EV-Board v1.4](#).

Unless otherwise stated, the ESP32-S3-LCD-EV-Board in this document refers to both **ESP32-S3-LCD-EV-Board** and **ESP32-S3-LCD-EV-Board-2**.

---

This user guide will help you get started with ESP32-S3-LCD-EV-Board and will also provide more in-depth information.

The document consists of the following sections:

- [Board Overview](#): Overview of the board hardware/software.
- [Start Application Development](#): How to set up hardware/software to develop applications.
- [Hardware Reference](#): More detailed information about the board's hardware.
- [Hardware Revision Details](#): This is the first revision of this board released.
- [Sample Request](#): How to get a sample board.
- [Related Documents](#): Links to related documentation.

#### 3.1.1 Board Overview

ESP32-S3-LCD-EV-Board is an ESP32-S3-based development board with a touchscreen. Together with different subboards, ESP32-S3-LCD-EV-Board can drive LCDs with IIC, SPI, 8080, and RGB interfaces. It houses dual array

microphones, supports voice recognition and near/far-field voice wake-up, and features screen and voice interaction. The board caters to development needs for touchscreen products with different resolutions and interfaces.

Currently, we have two boards available:

- ESP32-S3-LCD-EV-Board with 480x480 LCD
- ESP32-S3-LCD-EV-Board-2 with 800x480 LCD



Fig. 1: ESP32-S3-LCD-EV-Board with 480x480 LCD

### Feature List

The main features of the board are listed below:

- **Module Embedded:** ESP32-S3-WROOM-1 module with 16 MB flash and 16 MB PSRAM
- **Display:** Compatibility with various subboards and support for displays with RGB, 8080, SPI, and I2C interfaces. Please refer to [LCD Subboards](#) for more information
- **Audio:** Audio Codec + ADC amplifier and dual microphones
- **USB:** USB to serial port chip plus USB Type-C download/debug

### Block Diagram

The block diagram below shows the components of ESP32-S3-LCD-EV-Board and their interconnections.



Fig. 2: ESP32-S3-LCD-EV-Board-2 with 800x480 LCD

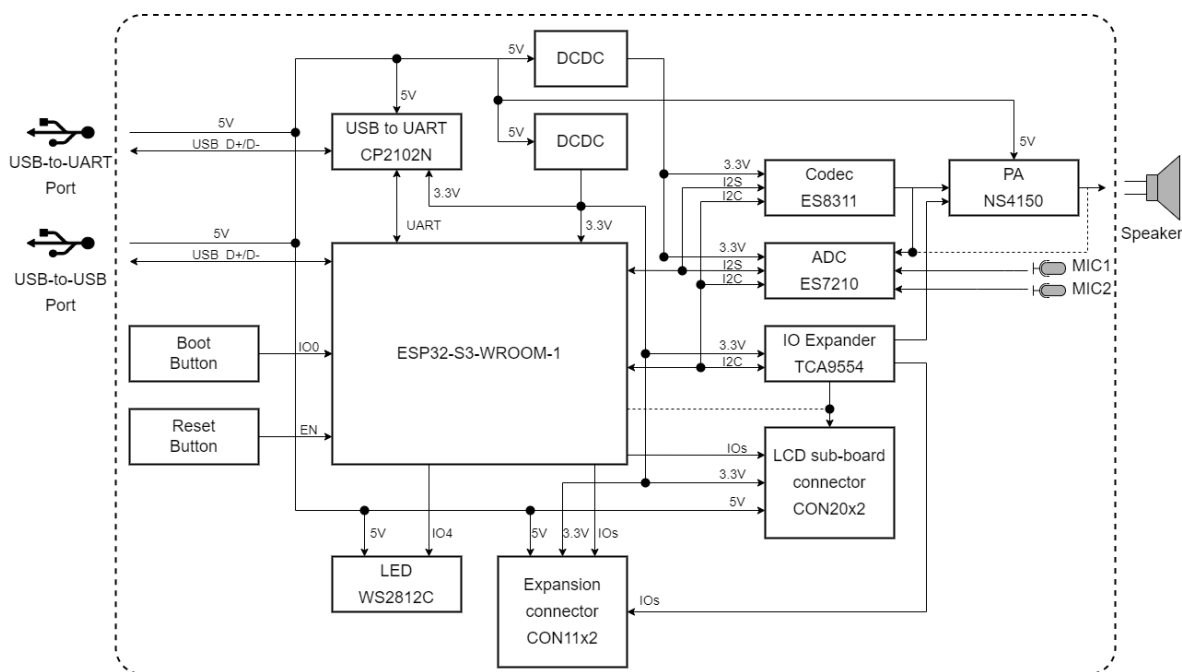

Fig. 3: ESP32-S3-LCD-EV-Board Block Diagram (Click to Enlarge)

## Description of Components

The ESP32-S3-LCD-EV-Board consists of a mainboard and a subboard (see [LCD Subboards](#) for options). Additionally, it allows for a selection of a USB Type-A adapter.

**Mainboard** **ESP32-S3-LCD-EV-Board-MB** is the core of the kit, which integrates the ESP32-S3-WROOM-1 module and provides ports for connection to the LCD subboard.

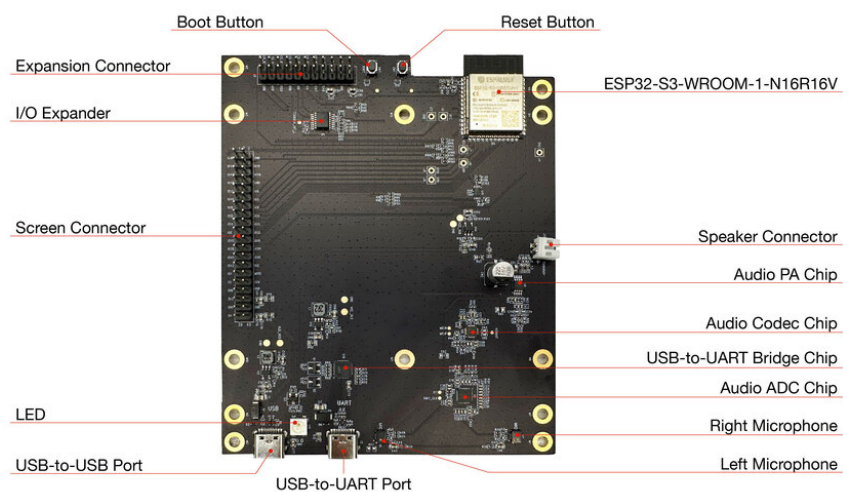

Fig. 4: ESP32-S3-LCD-EV-Board-MB - Front (Click to Enlarge)

The key components of the board are described in a counter-clockwise direction.

Key Component	Description
ESP32-S3-WROOM-1-N16R16V Module	ESP32-S3-WROOM-1-N16R16V is a generic Wi-Fi + Bluetooth LE MCU module that is built around the ESP32-S3 series of SoCs. It is integrated with 16 MB flash and 16 MB PSRAM. On top of a rich set of peripherals, the acceleration for neural network computing and signal processing workloads provided by the SoC makes the module an ideal choice for a wide variety of application scenarios related to Artificial Intelligence of Things (AIoT).
Reset Button	Press this button to reset the system.
Boot Button	Holding down the Boot key and momentarily pressing the Reset key initiates the firmware upload mode. Then you can upload firmware through the serial port or USB.
Expansion Connector	Provides connections for all I/O expander pins, all power supply pins, and some module pins.
I/O Expander	<a href="#">TCA9554</a> is a device that provides 8 bits of general purpose parallel I/O expansion. It controls the I/O mode and level via two-line bidirectional I2C bus, offering a simple solution when additional I/Os are needed.
LCD Board Connector	Three different types of LCD subboards can be connected via connectors with 2.54 mm pitch.
LED	Supports configuring the RGB LED display to indicate status or behavior.
USB-to-USB Port	Provides power to the entire system (choose either USB-to-USB or USB-to-UART port). It is recommended to use at least a 5V/2A power adapter to ensure stable power supply. Used for USB communication between the PC and the ESP32-S3-WROOM-1 module.
USB-to-UART Port	Provides power to the entire system (choose either USB-to-USB or USB-to-UART port). It is recommended to use at least a 5V/2A power adapter to ensure stable power supply. Used for serial communication between the PC side and the ESP32-S3-WROOM-1 module.
Left Microphone	On-board microphone, connected to Audio ADC Chip.
Right Microphone	On-board microphone, connected to Audio ADC Chip.
Audio ADC Chip	<a href="#">ES7210</a> is a high performance, low power 4-channel audio ADC for applications of microphone arrays. Featuring Acoustic Echo Cancellation (AEC), it is an ideal choice for music and voice applications.
USB-to-UART Bridge Controller	CP2102N, the single-chip USB-to-UART bridge controller, provides up to 3 Mbps connection for software download and debugging.
Audio Codec Chip	<a href="#">ES8311</a> is a low-power mono audio codec that includes a single-channel ADC and DAC, low noise pre-amplifier, headphone driver, digital audio, analog mixing, and gain function. It connects to the ESP32-S3-WROOM-1 module via I2S and I2C buses to process audio through hardware instead of the audio application.
Audio Amplifier	NS4150 is a low EMI, 3 W mono class D audio amplifier used to drive speakers by amplifying the audio signal from the audio codec chip.
Speaker Connector	External speaker playback is possible with the help of the audio amplifier.

**LCD Subboards** The mainboard can be used together with three different kinds of subboards:

Board Name	Display (Inch)	Resolution (Px)	LCD Driver (Interface)	Touch Driver	Available Boards	Development
ESP32-S3-LCD-EV-Board-SUB1 v1.0	0.96	128 x 64	<a href="#">SSD1315</a> (I2C)	N/A	Not Available	
	2.40	320 x 240	<a href="#">ST7789V</a> (SPI)	<a href="#">XTP2046</a>	Not Available	
ESP32-S3-LCD-EV-Board-SUB2 v1.5	3.50	480 x 320	<a href="#">ST7796S</a> (8080)	<a href="#">GT911</a>	Not Available	
	3.95	480 x 480	<a href="#">GC9503CV</a> (RGB)	<a href="#">FT5x06</a>	<a href="#">ESP32-S3-LCD-EV-Board</a>	
ESP32-S3-LCD-EV-Board-SUB3 v1.3	4.30	800 x 480	<a href="#">ST7262E43</a> (RGB)	<a href="#">GT1151</a>	<a href="#">ESP32-S3-LCD-EV-Board-2</a>	

- **ESP32-S3-LCD-EV-Board-SUB1** subboard has two interfaces, which support connection to a 2.4-inch display with the SPI interface or a 0.96-inch display with the I2C interface. This board is not yet configured, so it is not further explained here.
- **ESP32-S3-LCD-EV-Board-SUB2** subboard has two interfaces, which support connection to a display with the RGB interface or a display with the 8080 parallel interface. The current subboard has a 3.95-inch touchscreen with the RGB565 interface and 480x480 resolution. The LCD driver IC is GC9503CV and the touchscreen driver IC is FT5x06.



Fig. 5: ESP32-S3-LCD-EV-Board-SUB2 - Front (Click to Enlarge)

- **ESP32-S3-LCD-EV-Board-SUB3** subboard only supports a 4.3-inch touchscreen with the RGB565 interface and 800x480 resolution. The LCD driver IC is ST7262E43 and the touchscreen driver IC is GT1151.



Fig. 6: ESP32-S3-LCD-EV-Board-SUB2 - Back (Click to Enlarge)

**USB Type-A Adapter** With the USB Type-A adapter, the mainboard can serve as a USB host for connection to USB devices.

### Application Examples

The following application examples are available for ESP32-S3-LCD-EV-Board v1.5:

- [86-box Demo Example](#) - Demonstrates a GUI demo designed for a control panel (480x480) typically used for wall-mounted 86 type box, providing a smooth graphic operation experience with features like weather report, hot water heater, warm air heater page, and audio output function.
- [86-box Smart Panel Example](#) - Demonstrates a factory demo for a smart control panel with offline voice recognition function, providing a reference for flashing the board and troubleshooting potential issues.
- [LVGL Demos Example](#) - Demonstrates how to run LVGL's demos on an ESP32-S3-LCD-EV-Board, showcasing three methods to avoid tearing effect using different buffering modes, and providing performance testing results for different buffering modes.
- [Smart Panel Example](#) - Demonstrates a factory demo for a smart control panel with offline voice recognition function, providing instructions on how to flash the example to the ESP32-S3-LCD-EV-Board and configure it for use.
- [USB Camera LCD Example](#) - Demonstrates how to use an LCD display to show video captured from a USB camera, with options to transfer frames to Wi-Fi and log memory information, providing a basis for developing applications with ESP32-S3-LCD-EV-Board.
- [USB File System](#) - Demonstrates how to use USB HOST on ESP32-S2/ESP32-S3 to read and write files on a USB flash drive, displaying its contents on the screen, with support for various file formats for preview.
- [USB Keyboard Example](#) - Demonstrates how to use LCD and LVGL to simulate a USB keyboard on the ESP32-S3-LCD-EV-Board, providing a GUI of a USB keyboard that can interact with a PC like a real keyboard.

For more examples and the latest updates, please refer to the [examples](#) folder.



Fig. 7: ESP32-S3-LCD-EV-Board-SUB3 - Front (Click to Enlarge)

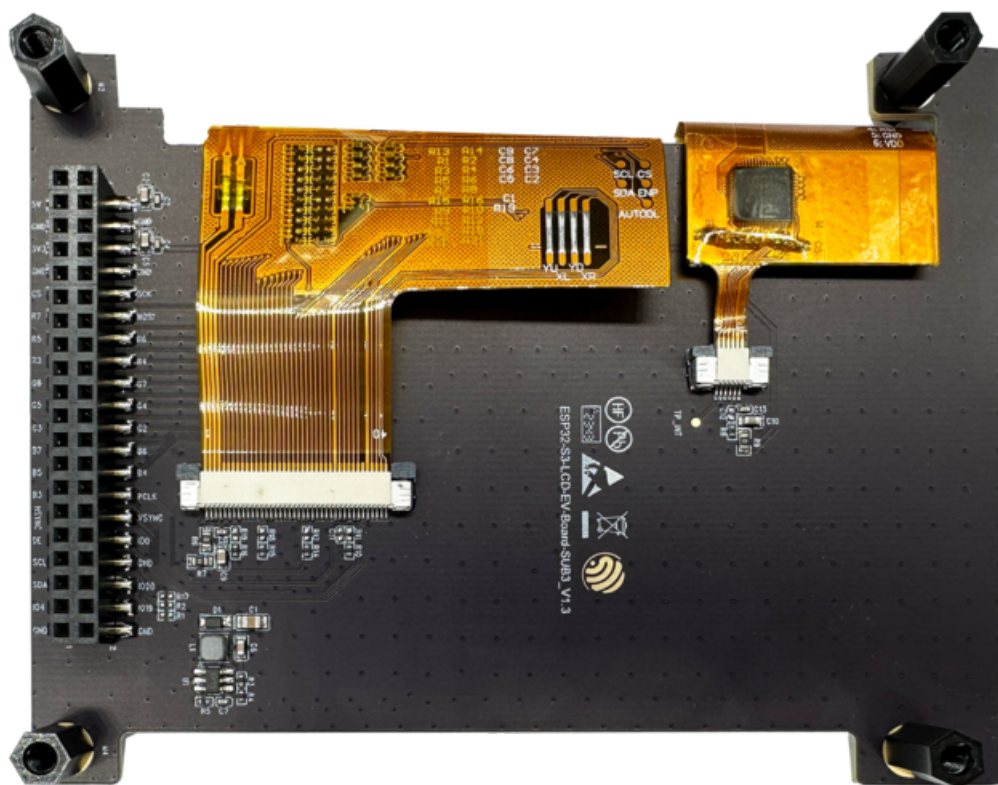

Fig. 8: ESP32-S3-LCD-EV-Board-SUB3 - Back (Click to Enlarge)

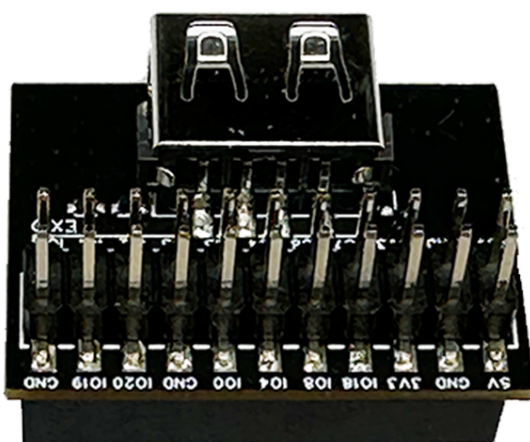

Fig. 9: USB Type-A Adapter v1.1 - Front (Click to Enlarge)

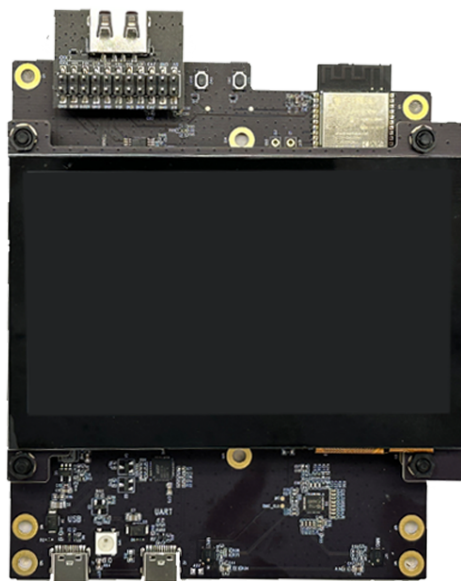

Fig. 10: USB Type-A Adapter v1.1 - Connected to the Mainboard (Click to Enlarge)

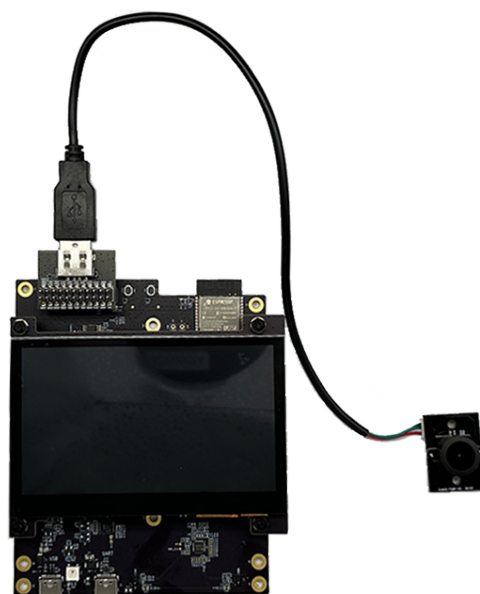

Fig. 11: USB Type-A Adapter v1.1 - Connected to USB Devices (Click to Enlarge)

To explore the application examples or to develop your own, please follow the steps outlined in the [Start Application Development](#) section.

### 3.1.2 Start Application Development

This section provides instructions on how to do hardware and software setup and flash firmware onto the board to develop your own application.

#### Required Hardware

- 1 x ESP32-S3-LCD-EV-Board-MB
- 1 x LCD subboard
- 1 x USB 2.0 cable (standard Type-A to Type-C)
- 1 x PC (Windows, Linux, or macOS)

---

**Note:** Please make sure to use the appropriate USB cable. Some cables can only be used for charging, not for data transfer or program flashing.

---

#### Optional Hardware

- 1 x Speaker

#### Hardware Setup

Prepare the board for loading of the first sample application:

1. Connect the LCD subboard to the **LCD Board Connector**.
2. Plug in the USB cable to connect the PC with the board.
3. The LCD lights up and you can start to interact with it.

Now the board is ready for software setup.

#### Software Setup

The development framework of ESP32-S3-LCD-EV-Board is [ESP-IDF](#). ESP-IDF is a FreeRTOS-based SoC development framework with a bunch of components including LCD, ADC, RMT, and SPI.

To learn how to quickly set up your development environment, please go to [Get Started > Installation](#).

---

#### Note:

- ESP-IDF v5.1.2 is required. It is recommended to use the latest release/v5.1 branch for development.
  - For more information about developing LCD applications, please refer to [ESP-IoT-Solution Programming Guide](#).
- 

### 3.1.3 Hardware Reference

This section provides more detailed information about the board's hardware.

## GPIO Allocation

The table below provides the allocation of GPIOs exposed on terminals of ESP32-S3-WROOM-1 module to control specific components or functions of the board.

Table 1: ESP32-S3-WROOM-1 GPIO Allocation

Pin	Pin Name	Function
1	GND	GND
2	3V3	Power supply
3	EN	RESET
4	IO4	LED
5	IO5	I2S_MCLK
6	IO6	I2S_CODEC_DSDIN
7	IO7	I2S_LRCK
8	IO15	I2S_ADC_SDOOUT
9	IO16	I2S_SCLK
10	IO17	LCD_DE
11	IO18	LCD_DATA7
12	IO8	LCD_DATA6
13	IO19	USB_D-
14	IO20	USB_D+
15	IO3	LCD_VSYNC
16	IO46	LCD_HSYNC
17	IO9	LCD_PCLK
18	IO10	LCD_DATA0
19	IO11	LCD_DATA1
20	IO12	LCD_DATA2
21	IO13	LCD_DATA3
22	IO14	LCD_DATA4
23	IO21	LCD_DATA5
24	IO47	I2C_SDA
25	IO48	I2C_SCL
26	IO45	LCD_DATA8
27	IO0	BOOT
28	IO35	No connection
29	IO36	No connection
30	IO37	No connection
31	IO38	LCD_DATA9
32	IO39	LCD_DATA10
33	IO40	LCD_DATA11
34	IO41	LCD_DATA12
35	IO42	LCD_DATA13
36	RXD0	UART_RXD0
37	TXD0	UART_TXD0
38	IO2	LCD_DATA14
39	IO1	LCD_DATA15
40	GND	GND
41	EPAD	GND

The pins on the I/O expander connected to the module can be used for different functions.

Table 2: I/O Expander GPIO Allocation

IO Expander Pin	Pin Name	Function
1	A0	GND
2	A1	GND
3	A2	GND
4	P0	PA_CTRL
5	P1	LCD_SPI_CS
6	P2	LCD_SPI_SCK
7	P3	LCD_SPI_MOSI
8	GND	GND
9	P4	Free
10	P5	Free
11	P6	Free
12	P7	Free
13	INT	No connection
14	SCL	I2C_SCL
15	SDA	I2C_SDA
16	VCC	Supply voltage

## Power Distribution

**Power Supply over USB** There are two ways to power the development board via USB power port.

- Via USB-to-USB port

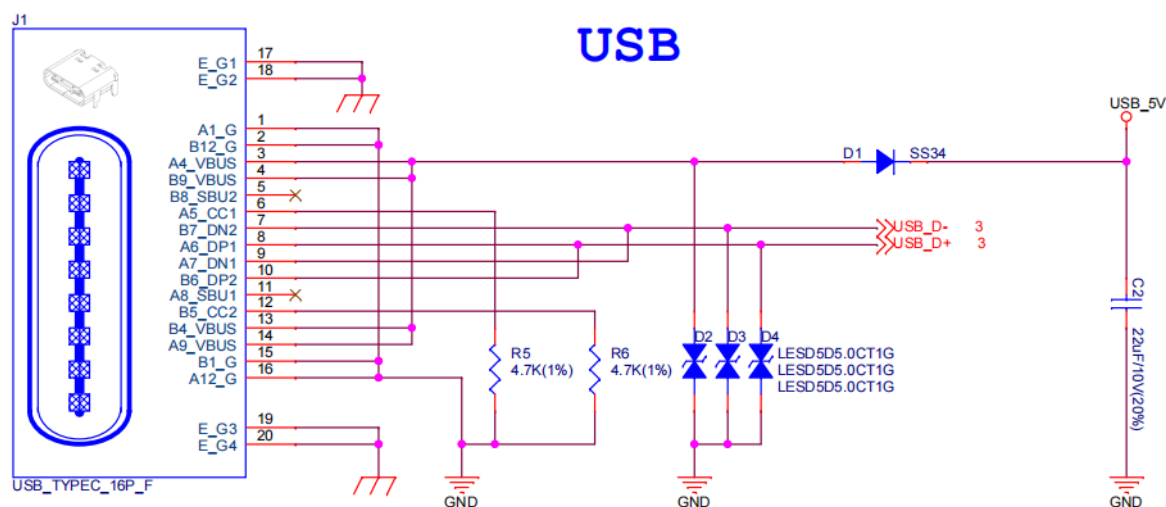

Fig. 12: ESP32-S3-LCD-EV-Board - USB-to-USB Power Supply

- Via USB-to-UART port

**Independent Audio and Digital Power Supply** ESP32-S3-LCD-EV-Board features independent power supplies for the audio components and ESP module. This should reduce noise in the audio signal from digital components and improve the overall performance of the components.

## AEC Path

The acoustic echo cancellation (AEC) path provides reference signals for AEC algorithm.

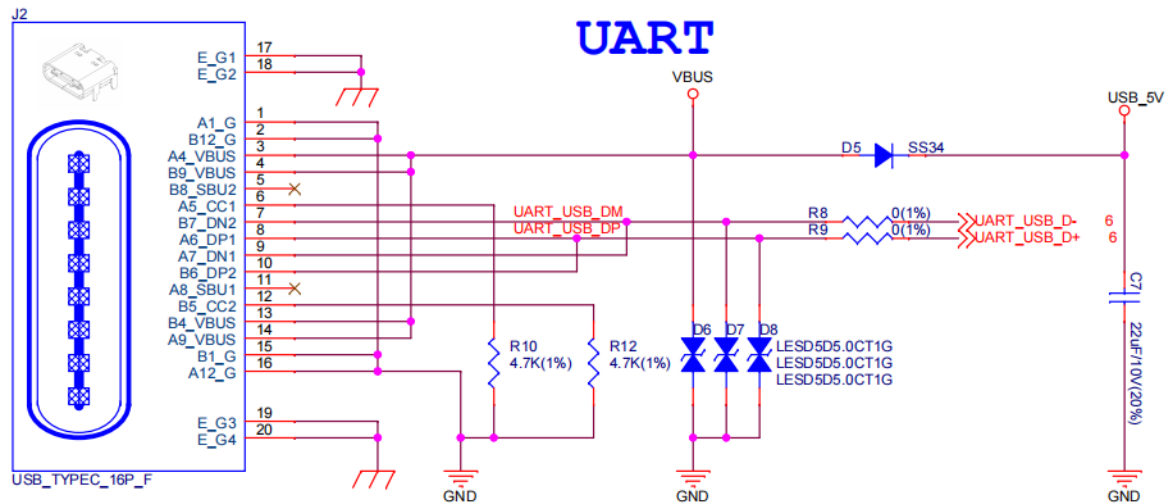

Fig. 13: ESP32-S3-LCD-EV-Board - USB-to-UART Power Supply

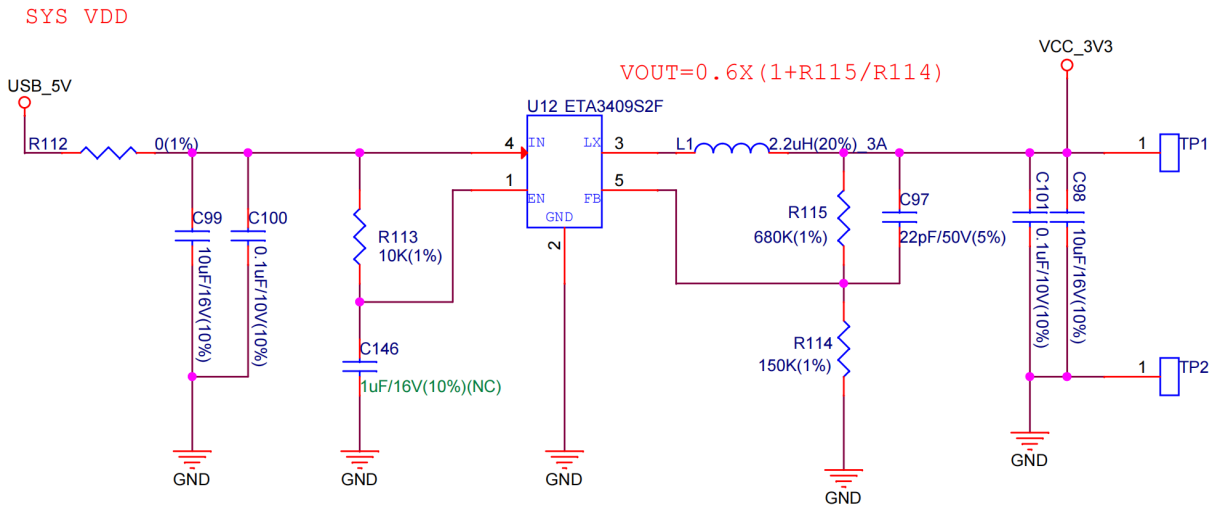

Fig. 14: ESP32-S3-LCD-EV-Board - Digital Power Supply

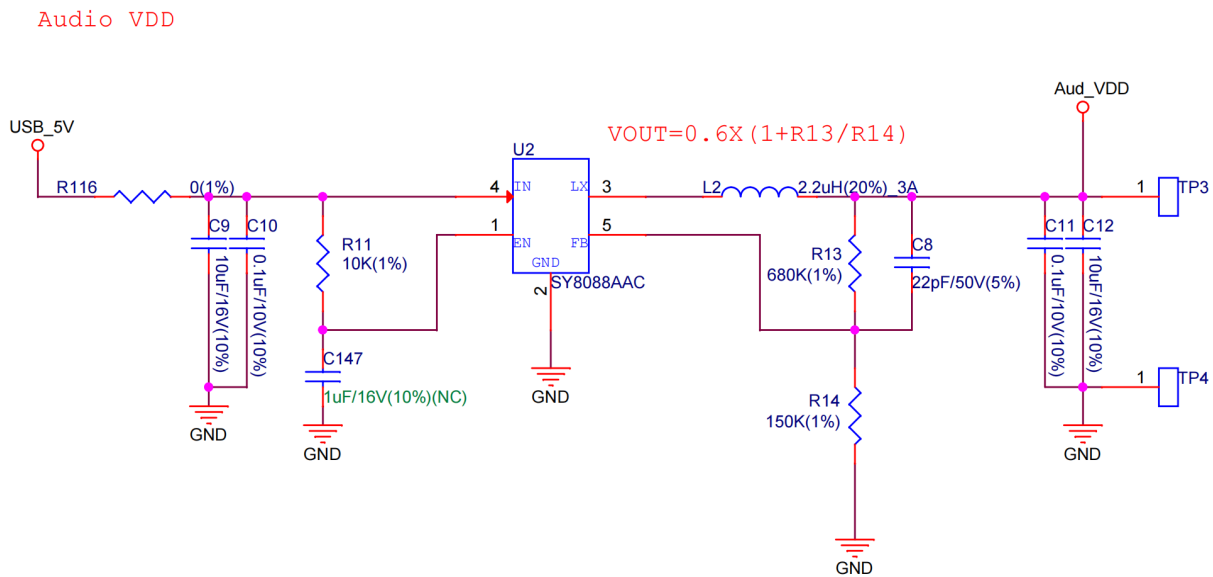

Fig. 15: ESP32-S3-LCD-EV-Board - Audio Power Supply

ESP32-S3-LCD-EV-Board provides two compatible echo reference signal source designs. One is Codec (ES8311) DAC output (DAC\_AOUTLP/DAC\_AOUTLP), the other is PA (NS4150) output (PA\_OUT+/PA\_OUT+). The former is a default and the recommended selection. Resistors R54 and R56 shown in the figure below should not be installed.

The echo reference signal is collected by ADC\_MIC3P/ADC\_MIC3N of ADC (ES7210) and then sent back to ESP32-S3 for AEC algorithm.

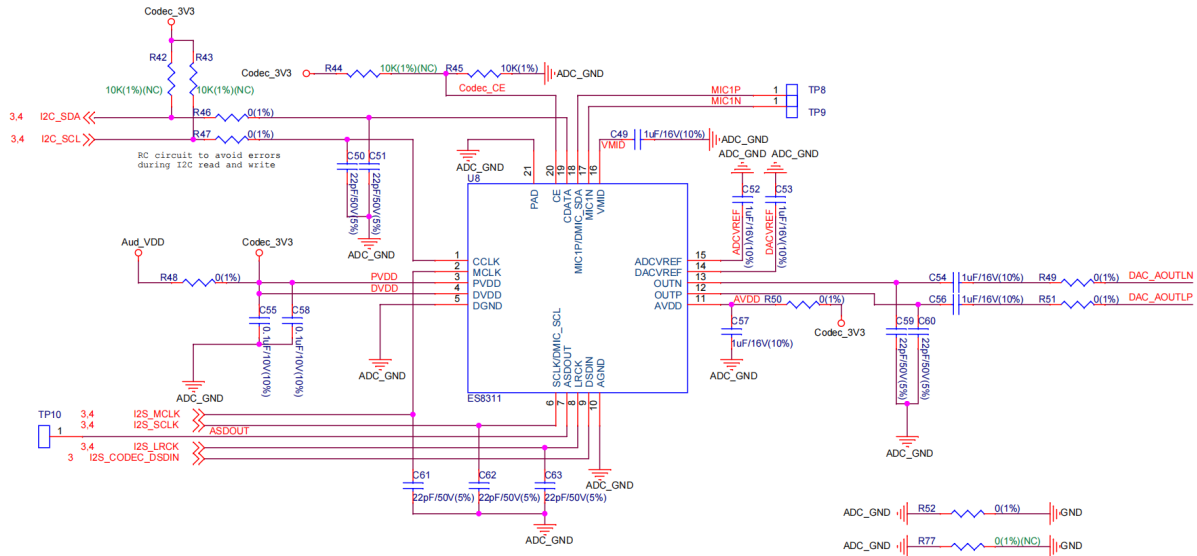

Fig. 16: ESP32-S3-LCD-EV-Board - AEC Codec DAC Output (Click to Enlarge)

**Hardware Setup Options**

**Automatic Download** There are two ways to put the development board into the download mode.

- Press the Boot and Reset buttons. Release the Reset button first and then the Boot button.
- The download is performed automatically by the software. The software uses the DTR and RTS signals from the serial port to control the status of the EN and IO0 pins.

**3.1.4 Hardware Revision Details**

**ESP32-S3-LCD-EV-Board v1.5**

- The following pins are re-allocated for the ESP32-S3-WROOM-1-N16R16V module:
  - I2C\_SCL: from IO18 to IO48
  - I2C\_SDA: from IO8 to IO47
  - LCD\_DATA6: from IO47 to IO8
  - LCD\_DATA7: from IO48 to IO18
- Level-shifting circuits are added to IO47 and IO48 for converting the 1.8 V logic level to a 3.3 V logic level.

**ESP32-S3-LCD-EV-Board v1.4**

- *Initial Release*

**3.1.5 Sample Request**

This development board with the USB Type-A adapter is suitable for evaluating Espressif’s high-performance [HMI Smart Displays Solution](#). For placing orders, please proceed to the Espressif [Online Shop](#).

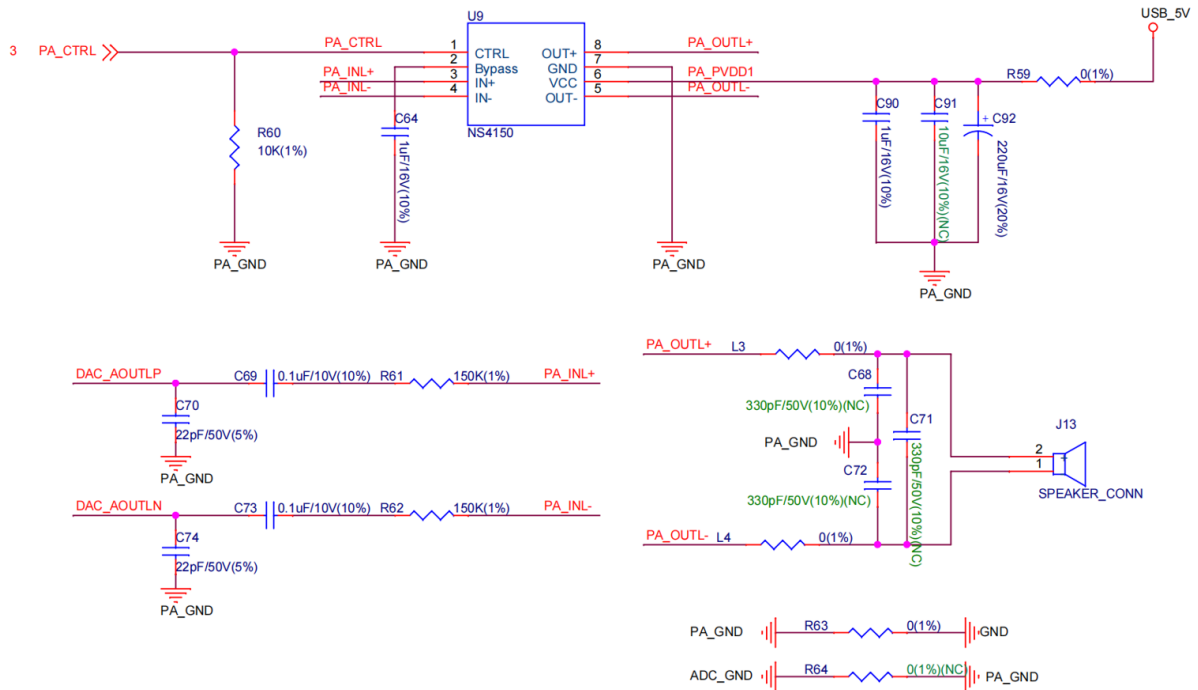

Fig. 17: SP32-S3-LCD-Ev-Board - AEC PA Output (Click to Enlarge)

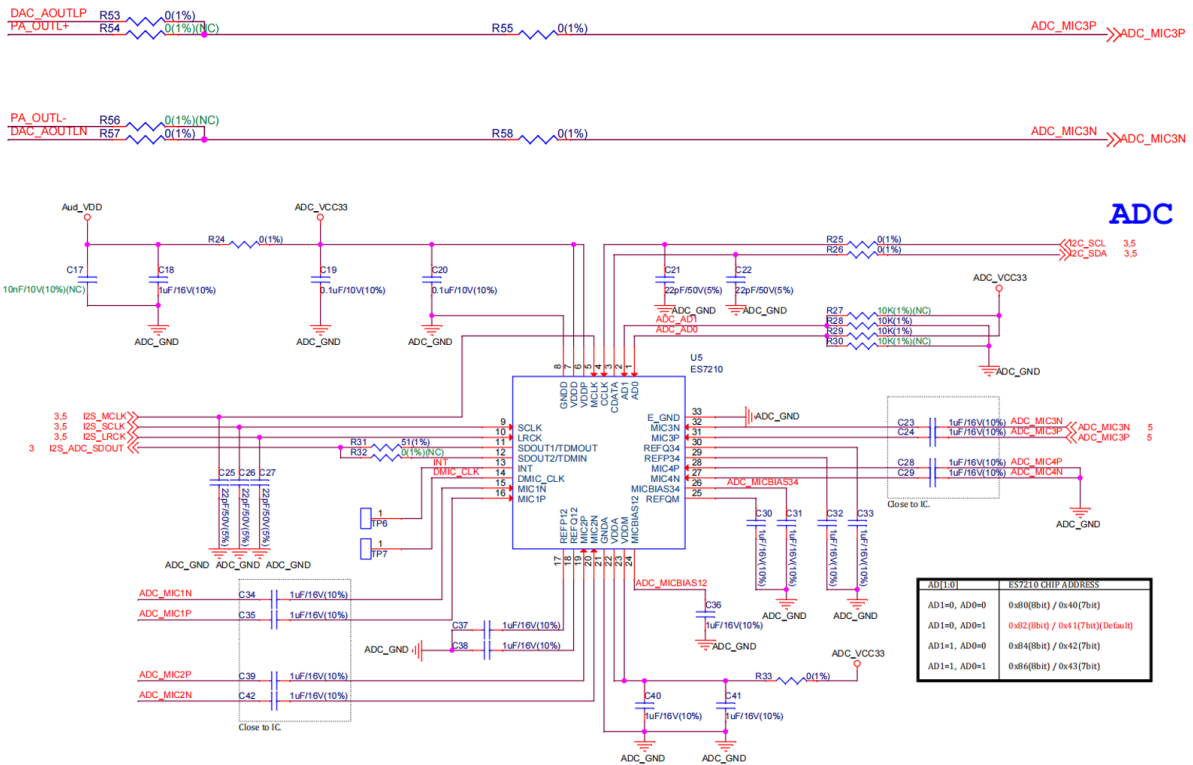

Fig. 18: ESP32-S3-LCD-EV-Board - AEC Reference Signal Collection (Click to Enlarge)

### 3.1.6 Related Documents

Please download the following documents from [the HTML version of esp-dev-kits Documentation](#).

- [ESP32-S3 Datasheet](#)
- [ESP32-S3-WROOM-1 Datasheet](#)
- [ESP Product Selector](#)
- [ESP32-S3-LCD-EV-Board-MB Schematics](#)
- [ESP32-S3-LCD-EV-Board-MB PCB Layout](#)
- [ESP32-S3-LCD-EV-Board-SUB1 Schematics](#)
- [ESP32-S3-LCD-EV-Board-SUB1 PCB Layout](#)
- [ESP32-S3-LCD-EV-Board-SUB2 Schematics](#)
- [ESP32-S3-LCD-EV-Board-SUB2 PCB Layout](#)
- [3.95\\_480x480\\_RGB\\_Display Specification](#)
- [ESP32-S3-LCD-EV-Board-SUB3 Schematics](#)
- [ESP32-S3-LCD-EV-Board-SUB3 PCB Layout](#)
- [ESP32-S3-LCD-EV-Board USB Adapter Schematics](#)
- [ESP32-S3-LCD-EV-Board USB Adapter PCB Layout](#)
- [TCA9554 Datasheet](#)
- [4.3\\_800x480\\_RGB\\_Display Specification](#)

For further design documentation for the board, please contact us at [sales@espressif.com](mailto:sales@espressif.com).

#### ESP32-S3-LCD-EV-Board v1.4

---

**Note:** Please check the version number of your ESP32-S3-LCD-EV-Board-MB indicated by the silk marking on the back. For boards of the v1.4 and below versions, please refer to this user guide. For boards of the v1.5 version, please refer to [ESP32-S3-LCD-EV-Board v1.5](#).

Unless otherwise stated, the ESP32-S3-LCD-EV-Board in this document refers to both **ESP32-S3-LCD-EV-Board** and **ESP32-S3-LCD-EV-Board-2**.

---

This user guide will help you get started with ESP32-S3-LCD-EV-Board and will also provide more in-depth information.

The document consists of the following sections:

- [Board Overview](#): Overview of the board hardware/software.
- [Start Application Development](#): How to set up hardware/software to develop applications.
- [Hardware Reference](#): More detailed information about the board's hardware.
- [Hardware Revision Details](#): This is the first revision of this board released.
- [Sample Request](#): How to get a sample board.
- [Related Documents](#): Links to related documentation.

**Board Overview** ESP32-S3-LCD-EV-Board is an ESP32-S3-based development board with a touchscreen. Together with different subboards, ESP32-S3-LCD-EV-Board can drive LCDs with IIC, SPI, 8080, and RGB interfaces. It houses dual array microphones, supports voice recognition and near/far-field voice wake-up, and features screen and voice interaction. The board caters to development needs for touchscreen products with different resolutions and interfaces.

Currently, we have two boards available:

- ESP32-S3-LCD-EV-Board with 480x480 LCD
- ESP32-S3-LCD-EV-Board-2 with 800x480 LCD



Fig. 19: ESP32-S3-LCD-EV-Board with 480x480 LCD



Fig. 20: ESP32-S3-LCD-EV-Board-2 with 800x480 LCD

**Feature List** The main features of the board are listed below:

- **Module Embedded:** ESP32-S3-WROOM-1 module with 16 MB flash and 8 MB PSRAM
- **Display:** Compatibility with various subboards and support for displays with RGB, 8080, SPI, and I2C interfaces. Please refer to [LCD Subboards](#) for more information
- **Audio:** Audio Codec + ADC amplifier and dual microphones
- **USB:** USB to serial port chip plus USB Type-C download/debug

**Block Diagram** The block diagram below shows the components of ESP32-S3-LCD-EV-Board and their inter-connections.

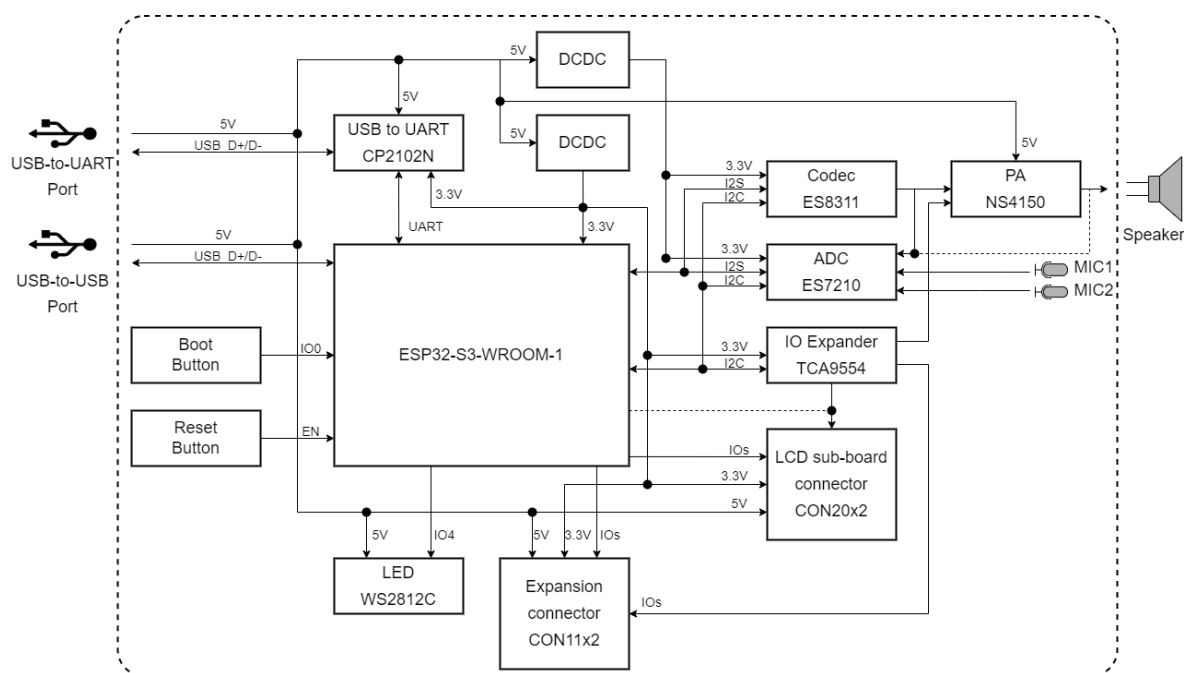

Fig. 21: ESP32-S3-LCD-EV-Board Block Diagram (Click to Enlarge)

**Description of Components** The ESP32-S3-LCD-EV-Board development board consists of a mainboard and a subboard (see [LCD Subboards](#) for options). Additionally, it allows for a selection of a USB Type-A adapter.

**Mainboard** **ESP32-S3-LCD-EV-Board-MB** is the core of the kit, which integrates the ESP32-S3-WROOM-1 module and provides ports for connection to the LCD subboard.

The key components of the board are described in a counter-clockwise direction.

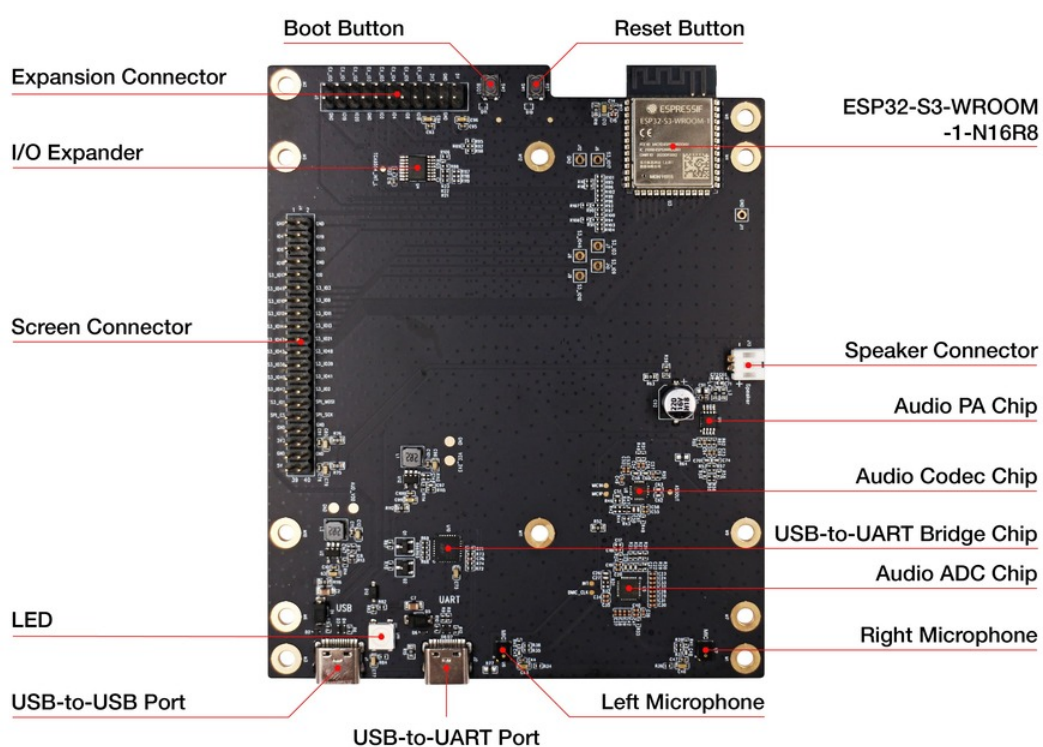

Fig. 22: ESP32-S3-LCD-EV-Board-MB - Front (Click to Enlarge)

Key Component	Description
ESP32-S3-WROOM-1-N16R8 Module	ESP32-S3-WROOM-1-N16R8 is a generic Wi-Fi + Bluetooth LE MCU module that is built around the ESP32-S3 series of SoCs. It is integrated with 16 MB flash and 8 MB PSRAM. On top of a rich set of peripherals, the acceleration for neural network computing and signal processing workloads provided by the SoC makes the module an ideal choice for a wide variety of application scenarios related to Artificial Intelligence of Things (AIoT).
Reset Button	Press this button to reset the system.
Boot Button	Holding down the Boot key and momentarily pressing the Reset key initiates the firmware upload mode. Then you can upload firmware through the serial port or USB.
Expansion Connector	Provides connections for all I/O expander pins, all power supply pins, and some module pins.
I/O Expander	<a href="#">TCA9554</a> is a device that provides 8 bits of general purpose parallel I/O expansion. It controls the I/O mode and level via two-line bidirectional I2C bus, offering a simple solution when additional I/Os are needed.
LCD Board Connector	Three different types of LCD subboards can be connected via connectors with 2.54 mm pitch.
LED	Supports configuring the RGB LED display to indicate status or behavior.
USB-to-USB Port	Provides power to the entire system (choose either USB-to-USB or USB-to-UART port). It is recommended to use at least a 5V/2A power adapter to ensure stable power supply. Used for USB communication between the PC and the ESP32-S3-WROOM-1 module.
USB-to-UART Port	Provides power to the entire system (choose either USB-to-USB or USB-to-UART port). It is recommended to use at least a 5V/2A power adapter to ensure stable power supply. Used for serial communication between the PC side and the ESP32-S3-WROOM-1 module.
Left Microphone	On-board microphone, connected to Audio ADC Chip.
Right Microphone	On-board microphone, connected to Audio ADC Chip.
Audio ADC Chip	<a href="#">ES7210</a> is a high performance, low power 4-channel audio ADC for applications of microphone arrays. Featuring Acoustic Echo Cancellation (AEC), it is an ideal choice for music and voice applications.
USB-to-UART Bridge Controller	CP2102N, the single-chip USB-to-UART bridge controller, provides up to 3 Mbps connection for software download and debugging.
Audio Codec Chip	<a href="#">ES8311</a> is a low-power mono audio codec that includes a single-channel ADC and DAC, low noise pre-amplifier, headphone driver, digital audio, analog mixing, and gain function. It connects to the ESP32-S3-WROOM-1 module via I2S and I2C buses to process audio through hardware instead of the audio application.
Audio Amplifier	NS4150 is a low EMI, 3 W mono class D audio amplifier used to drive speakers by amplifying the audio signal from the audio codec chip.
Speaker Connector	External speaker playback is possible with the help of the audio amplifier.

**LCD Subboards** The mainboard can be used together with three different kinds of subboards:

Board Name	Display (Inch)	Resolution (Px)	LCD Driver (Interface)	Touch Driver	Available Boards	Development
ESP32-S3-LCD-EV-Board-SUB1 v1.0	0.96	128 x 64	<a href="#">SSD1315</a> (I2C)	Not Available	Not Available	
	2.40	320 x 240	<a href="#">ST7789V</a> (SPI)	<a href="#">XTP2046</a>	Not Available	
ESP32-S3-LCD-EV-Board-SUB2 v1.4	3.50	480 x 320	<a href="#">ST7796S</a> (8080)	<a href="#">GT911</a>	Not Available	
	3.95	480 x 480	<a href="#">GC9503CV</a> (RGB)	<a href="#">FT5x06</a>	<a href="#">ESP32-S3-LCD-EV-Board</a>	
ESP32-S3-LCD-EV-Board-SUB3 v1.3	4.30	800 x 480	<a href="#">ST7262E43</a> (RGB)	<a href="#">GT1151</a>	<a href="#">ESP32-S3-LCD-EV-Board-2</a>	

- The **ESP32-S3-LCD-EV-Board-SUB1** subboard has two interfaces, which support connection to a 2.4-inch display with the SPI interface or a 0.96-inch display with the I2C interface. This board is not yet configured, so it is not further explained here.
- The **ESP32-S3-LCD-EV-Board-SUB2** subboard has two interfaces, which support connection to a display with the RGB interface or a display with the 8080 parallel interface. The current subboard has a 3.95-inch touchscreen with the RGB565 interface and 480x480 resolution. The LCD driver IC is GC9503CV and the touchscreen driver IC is FT5x06.



Fig. 23: ESP32-S3-LCD-EV-Board-SUB2 - Front (Click to Enlarge)

- The **ESP32-S3-LCD-EV-Board-SUB3** subboard only supports a 4.3-inch touchscreen with the RGB565



Fig. 24: ESP32-S3-LCD-EV-Board-SUB2 - Back (Click to Enlarge)

interface and 800x480 resolution. The LCD driver IC is ST7262E43 and the touchscreen driver IC is GT1151.

**USB Type-A Adapter** With the USB Type-A adapter, the mainboard can serve as a USB host for connection to USB devices.

**Application Examples** The following application examples are available for ESP32-S3-LCD-EV-Board v1.4:

- [86-box Demo Example](#) - Demonstrates a GUI demo designed for a control panel (480x480) typically used for wall-mounted 86 type box, providing a smooth graphic operation experience with features like weather report, hot water heater, warm air heater page, and audio output function.
- [86-box Smart Panel Example](#) - Demonstrates a factory demo for a smart control panel with offline voice recognition function, providing a reference for flashing the board and troubleshooting potential issues.
- [LVGL Demos Example](#) - Demonstrates how to run LVGL's demos on an ESP32-S3-LCD-EV-Board, showcasing three methods to avoid tearing effect using different buffering modes, and providing performance testing results for different buffering modes.
- [Smart Panel Example](#) - Demonstrates a factory demo for a smart control panel with offline voice recognition function, providing instructions on how to flash the example to the ESP32-S3-LCD-EV-Board and configure it for use.
- [USB Camera LCD Example](#) - Demonstrates how to use an LCD display to show video captured from a USB camera, with options to transfer frames to Wi-Fi and log memory information, providing a basis for developing applications with ESP32-S3-LCD-EV-Board.
- [USB File System](#) - Demonstrates how to use USB HOST on ESP32-S2/ESP32-S3 to read and write files on a USB flash drive, displaying its contents on the screen, with support for various file formats for preview.
- [USB Keyboard Example](#) - Demonstrates how to use LCD and LVGL to simulate a USB keyboard on the ESP32-S3-LCD-EV-Board, providing a GUI of a USB keyboard that can interact with a PC like a real keyboard.

For more examples and the latest updates, please refer to the [examples](#) folder.



Fig. 25: ESP32-S3-LCD-EV-Board-SUB3 - Front (Click to Enlarge)

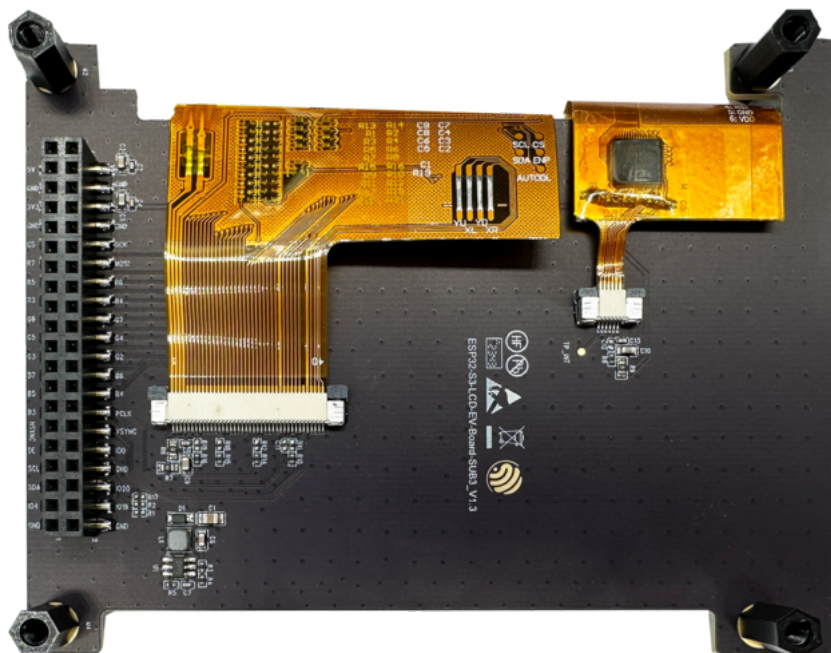

Fig. 26: ESP32-S3-LCD-EV-Board-SUB3 - Back (Click to Enlarge)

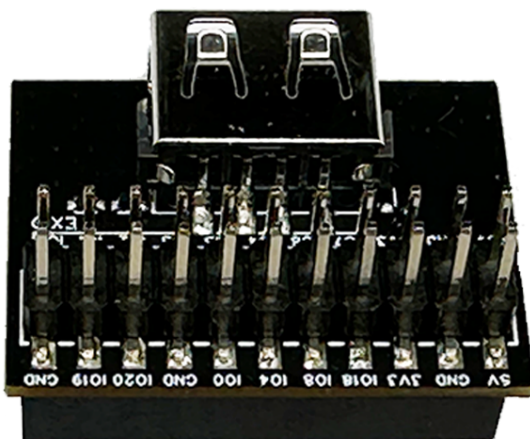

Fig. 27: USB Type-A Adapter v1.1 - Front (Click to Enlarge)

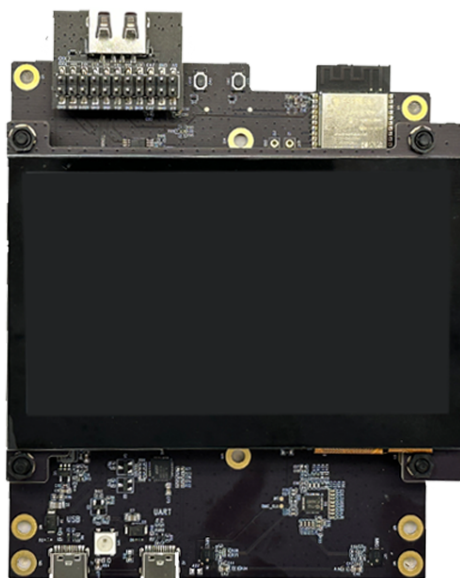

Fig. 28: USB Type-A Adapter v1.1 - Connected to the Mainboard (Click to Enlarge)

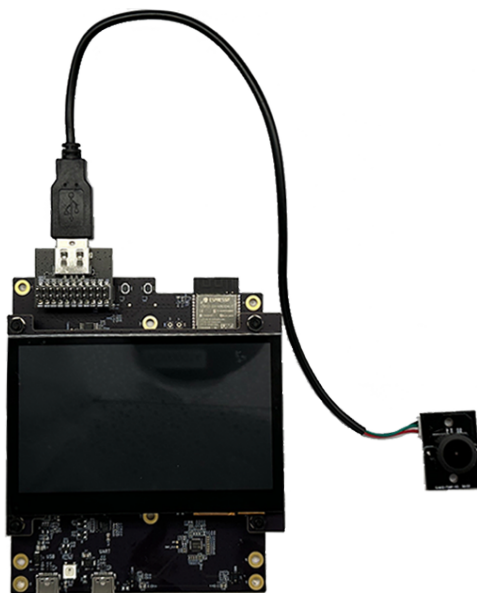

Fig. 29: USB Type-A Adapter v1.1 - Connected to USB Devices (Click to Enlarge)

To explore the application examples or to develop your own, please follow the steps outlined in the [Start Application Development](#) section.

**Start Application Development** This section provides instructions on how to do hardware and software setup and flash firmware onto the board to develop your own application.

#### Required Hardware

- 1 x ESP32-S3-LCD-EV-Board-MB
- 1 x LCD subboard
- 1 x USB 2.0 cable (standard Type-A to Type-C)
- 1 x PC (Windows, Linux, or macOS)

---

**Note:** Please make sure to use the appropriate USB cable. Some cables can only be used for charging, not for data transfer or program flashing.

---

#### Optional Hardware

- 1 x Speaker

**Hardware Setup** Prepare the board for loading of the first sample application:

1. Connect the LCD subboard to the **LCD Board Connector**.
2. Plug in the USB cable to connect the PC with the board.
3. The LCD lights up and you can start to interact with it.

Now the board is ready for software setup.

**Software Setup** The development framework of ESP32-S3-LCD-EV-Board is [ESP-IDF](#). ESP-IDF is a FreeRTOS-based SoC development framework with a bunch of components including LCD, ADC, RMT, and SPI.

To learn how to quickly set up your development environment, please go to [Get Started > Installation](#).

**Note:**

- ESP-IDF v5.1.2 is required. It is recommended to use the latest release/v5.1 branch for development.
- For more information about developing LCD applications, please refer to [ESP-IoT-Solution Programming Guide](#).

**Hardware Reference** This section provides more detailed information about the board's hardware.

**GPIO Allocation** The table below provides the allocation of GPIOs exposed on terminals of ESP32-S3-WROOM-1 module to control specific components or functions of the board.

Table 3: ESP32-S3-WROOM-1 GPIO Allocation

Pin	Pin Name	Function
1	GND	GND
2	3V3	Power supply
3	EN	RESET
4	IO4	LED
5	IO5	I2S_MCLK
6	IO6	I2S_CODEC_DSDIN
7	IO7	I2S_LRCK
8	IO15	I2S_ADC_SDOOUT
9	IO16	I2S_SCLK
10	IO17	LCD_DE
11	IO18	I2C_SCL
12	IO8	I2C_SDA
13	IO19	USB_D-
14	IO20	USB_D+
15	IO3	LCD_VSYNC
16	IO46	LCD_HSYNC
17	IO9	LCD_PCLK
18	IO10	LCD_DATA0
19	IO11	LCD_DATA1
20	IO12	LCD_DATA2
21	IO13	LCD_DATA3
22	IO14	LCD_DATA4
23	IO21	LCD_DATA5
24	IO47	LCD_DATA6
25	IO48	LCD_DATA7
26	IO45	LCD_DATA8
27	IO0	BOOT
28	IO35	No connection
29	IO36	No connection
30	IO37	No connection
31	IO38	LCD_DATA9
32	IO39	LCD_DATA10
33	IO40	LCD_DATA11
34	IO41	LCD_DATA12
35	IO42	LCD_DATA13
36	RXD0	UART_RXD0
37	TXD0	UART_TXD0
38	IO2	LCD_DATA14

continues on next page

Table 3 – continued from previous page

Pin	Pin Name	Function
39	IO1	LCD_DATA15
40	GND	GND
41	EPAD	GND

The pins on the I/O expander connected to the module can be used for different functions.

Table 4: I/O Expander GPIO Allocation

IO Expander Pin	Pin Name	Function
1	A0	GND
2	A1	GND
3	A2	GND
4	P0	PA_CTRL
5	P1	LCD_SPL_CS
6	P2	LCD_SPL_SCK
7	P3	LCD_SPL_MOSI
8	GND	GND
9	P4	Free
10	P5	Free
11	P6	Free
12	P7	Free
13	INT	No connection
14	SCL	I2C_SCL
15	SDA	I2C_SDA
16	VCC	Supply voltage

## Power Distribution

**Power Supply over USB** There are two ways to power the development board via USB power port.

- Via USB-to-USB port

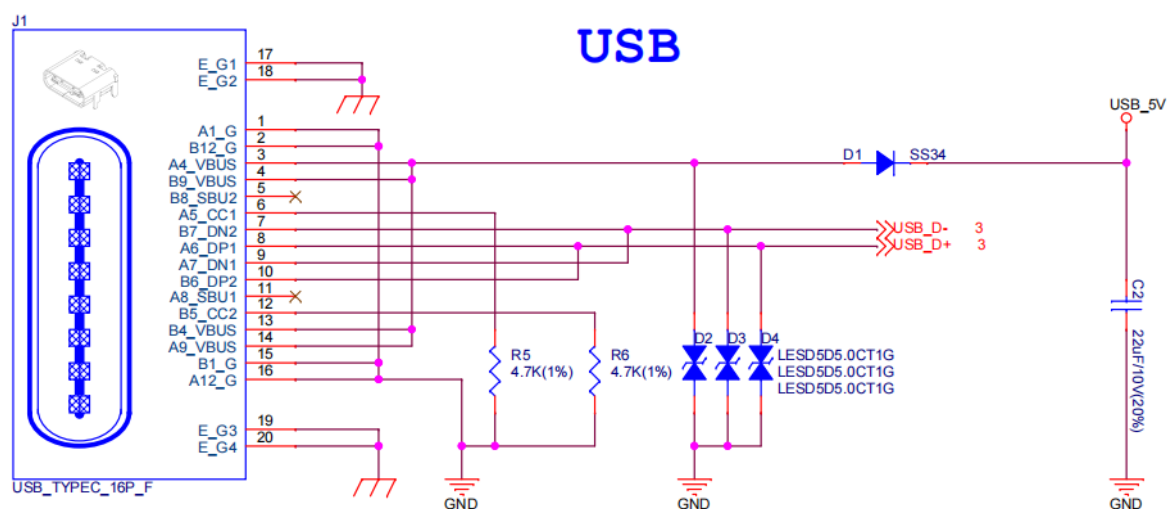

Fig. 30: ESP32-S3-LCD-EV-Board - USB-to-USB Power Supply

- Via USB-to-UART port

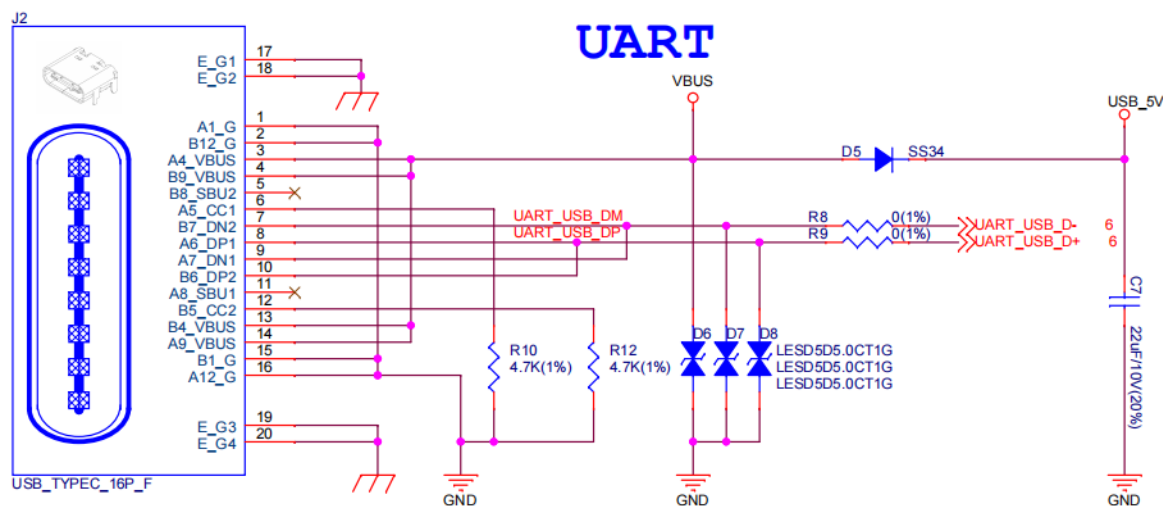

Fig. 31: ESP32-S3-LCD-EV-Board - USB-to-UART Power Supply

**Independent Audio and Digital Power Supply** ESP32-S3-LCD-EV-Board features independent power supplies for the audio components and ESP module. This should reduce noise in the audio signal from digital components and improve the overall performance of the components.

**SYS VDD**

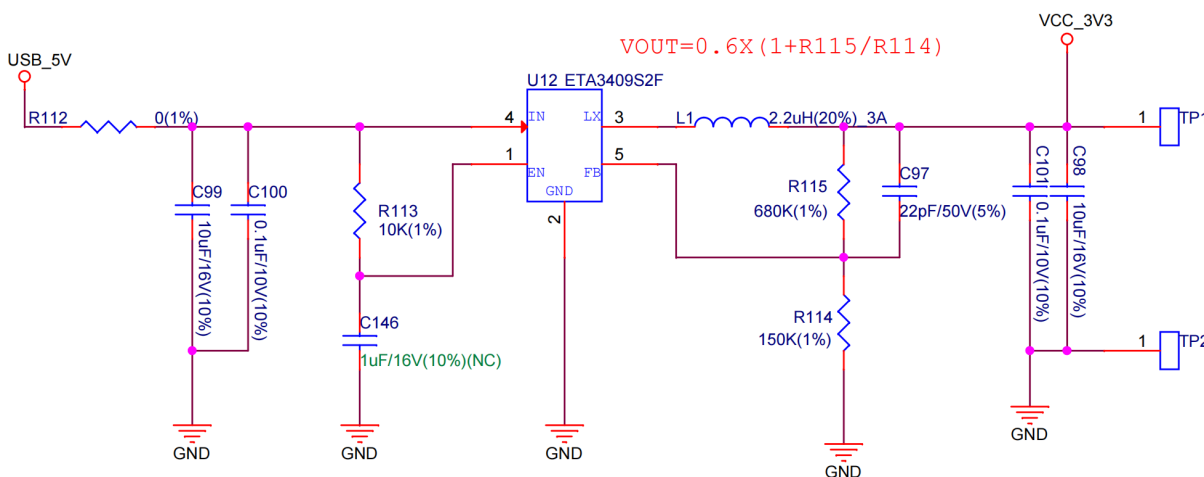

Fig. 32: ESP32-S3-LCD-EV-Board - Digital Power Supply

**AEC Path** The acoustic echo cancellation (AEC) path provides reference signals for AEC algorithm.

ESP32-S3-LCD-EV-Board provides two compatible echo reference signal source designs. One is Codec (ES8311) DAC output (DAC\_AOUTLP/DAC\_AOUTLP), the other is PA (NS4150) output (PA\_OUT+/PA\_OUT+). The former is a default and the recommended selection. Resistors R54 and R56 shown in the figure below should not be installed.

The echo reference signal is collected by ADC\_MIC3P/ADC\_MIC3N of ADC (ES7210) and then sent back to ESP32-S3 for AEC algorithm.

**Hardware Setup Options**

**Automatic Download** There are two ways to put the development board into the download mode.

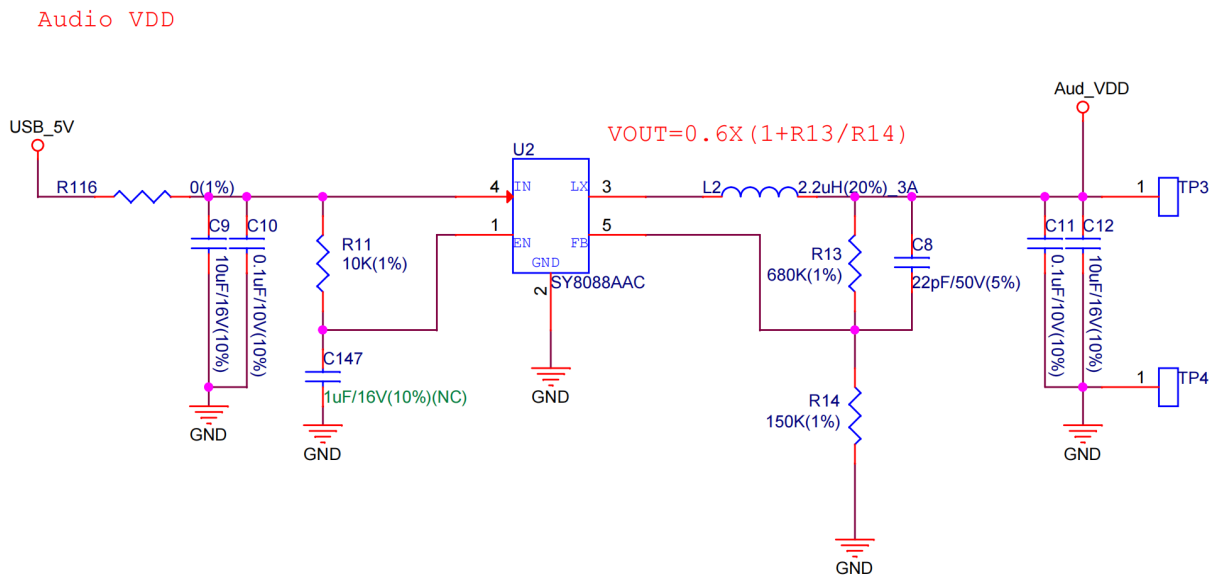

Fig. 33: ESP32-S3-LCD-EV-Board - Audio Power Supply

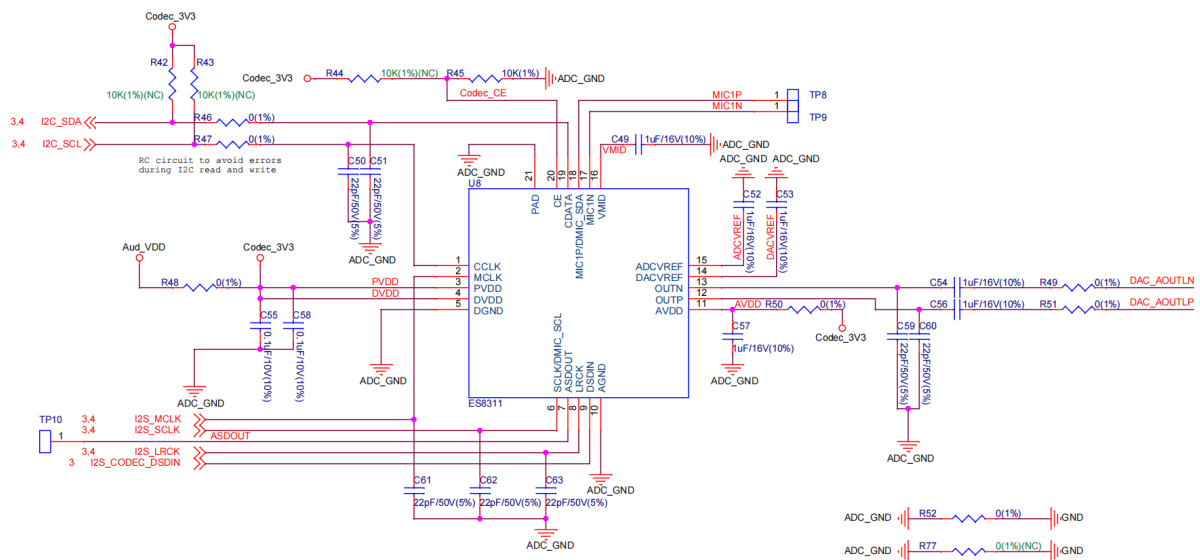

Fig. 34: ESP32-S3-LCD-EV-Board - AEC Codec DAC Output (Click to Enlarge)

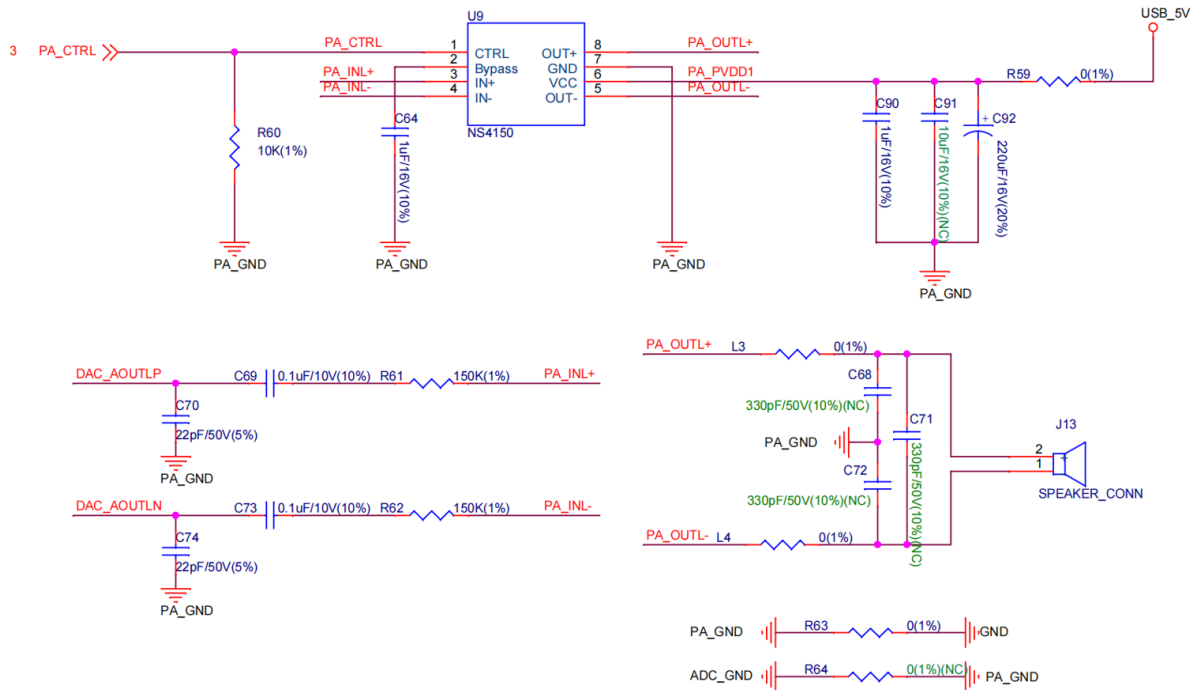

Fig. 35: SP32-S3-LCD-Ev-Board - AEC PA Output (Click to Enlarge)

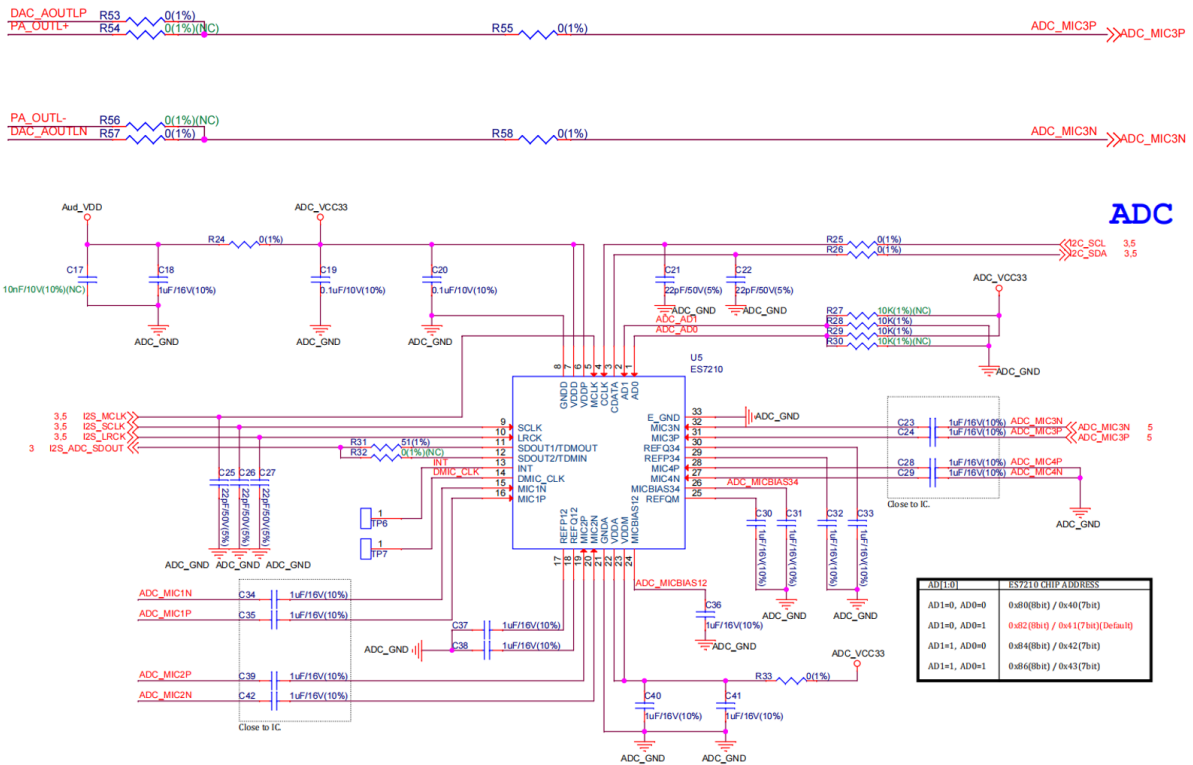

Fig. 36: ESP32-S3-LCD-EV-Board - AEC Reference Signal Collection (Click to Enlarge)

- Press the Boot and Reset buttons. Release the Reset button first and then the Boot button.
- The download is performed automatically by the software. The software uses the DTR and RTS signals from the serial port to control the status of the EN and IO0 pins.

**Hardware Revision Details** No previous revisions.

**Sample Request** This development board with the USB Type-A adapter is suitable for evaluating Espressif's high-performance [HMI Smart Displays Solution](#). For placing orders, please proceed to the Espressif [Online Shop](#).

**Related Documents** Please download the following documents from [the HTML version of esp-dev-kits Documentation](#).

- [ESP32-S3 Datasheet](#)
- [ESP32-S3-WROOM-1 Datasheet](#)
- [ESP Product Selector](#)
- [ESP32-S3-LCD-EV-Board-MB Schematics](#)
- [ESP32-S3-LCD-EV-Board-MB PCB Layout](#)
- [ESP32-S3-LCD-EV-Board-SUB1 Schematics](#)
- [ESP32-S3-LCD-EV-Board-SUB1 PCB Layout](#)
- [ESP32-S3-LCD-EV-Board-SUB2 Schematics](#)
- [ESP32-S3-LCD-EV-Board-SUB2 PCB Layout](#)
- [ESP32-S3-LCD-EV-Board-SUB3 Schematics](#)
- [ESP32-S3-LCD-EV-Board-SUB3 PCB Layout](#)
- [ESP32-S3-LCD-EV-Board USB Adapter Schematics](#)
- [ESP32-S3-LCD-EV-Board USB Adapter PCB Layout](#)
- [TCA9554 Datasheet](#)

For further design documentation for the board, please contact us at [sales@espressif.com](mailto:sales@espressif.com).



## Chapter 4

# ESP-VoCat

ESP-VoCat is an intelligent AI development kit. It is suitable for voice interaction products that require large model capabilities, such as toys, smart speakers, and smart central control systems. The device is equipped with an ESP32-S3 module, a 1.85-inch QSPI circular touch screen, dual microphone array, and supports offline voice wake-up and sound source localization algorithms. Combined with the large model capabilities provided by OpenAI, Xiaozhi AI, Gemini, etc., ESP-VoCat can achieve full-duplex voice interaction, multimodal recognition, and intelligent agent control, providing a solid foundation for developers to create complete edge-side AI application experiences.

Application examples for the development board are stored in the [esp-brookesia](#) project.

---

**Note:** Please check the silkscreen version number on the mainboard to confirm your development board version. For v1.0 version development boards, please refer to [ESP-VoCat v1.0](#); for v1.2 version development boards, please refer to [ESP-VoCat v1.2](#).

---

### 4.1 ESP-VoCat v1.2

---

**Note:** Please check the silkscreen version number on the mainboard to confirm your development board version. For v1.0 version development boards, please refer to [ESP-VoCat v1.0](#); For v1.2 version development boards, please refer to the current user guide.

---

This guide will help you get started with ESP-VoCat quickly and provide detailed information about this development board.

ESP-VoCat is an intelligent AI development kit. It is suitable for voice interaction products that require large model capabilities, such as toys, smart speakers, and smart central control systems. The device is equipped with a 1.85-inch QSPI circular touch screen, dual microphone array, and supports offline voice wake-up and sound source localization algorithms. Combined with the large model capabilities provided by OpenAI, Xiaozhi AI, Gemini, etc., ESP-VoCat can achieve full-duplex voice interaction, multimodal recognition, and intelligent agent control, providing a solid foundation for developers to create complete edge-side AI application experiences.

ESP-VoCat's main controller uses the Espressif ESP32-S3-WROOM-1-N16R16VA module, supporting 2.4 GHz Wi-Fi and Bluetooth 5 (LE) wireless connectivity. For storage, the entire device has 16MB PSRAM and 16MB Flash storage space, and is also equipped with a microSD card slot that can support up to 32GB, meeting the needs of voice interaction and multimedia processing. It features a 1.85-inch circular touch screen (360 × 360 resolution) with ESP32-S3 native touch sensors, providing an intuitive and rich interactive experience.

For audio, ESP-VoCat has a built-in 3W speaker and dual microphone array, supporting local voice wake-up and sound source localization. The power system is compatible with 5 V DC and 3.7 V lithium battery power supply. Additionally, it integrates a USB-C interface for power supply and programming download, while reserving a PogoPin interface for convenient functional expansion.



Fig. 1: ESP-VoCat Front View (Click to enlarge)

The document consists of the following major sections:

- *Getting Started*: Overview of the board and hardware/software setup instructions to get started.
- *Hardware Reference*: More detailed information about the board's hardware.
- *Hardware Revision Details*: Hardware revision history and known issues (if any) of the board.
- *Related Documents*: Links to related documentation.

### 4.1.1 Getting Started

This section provides a brief introduction of ESP-VoCat, instructions on how to do the initial hardware setup and how to flash firmware onto it.

#### Description of Components

The following introduces the main components on the front PCB in clockwise order. For user convenience, we have also labeled these components or interfaces on the ESP-VoCat housing.



Fig. 2: ESP-VoCat Back View (Click to enlarge)

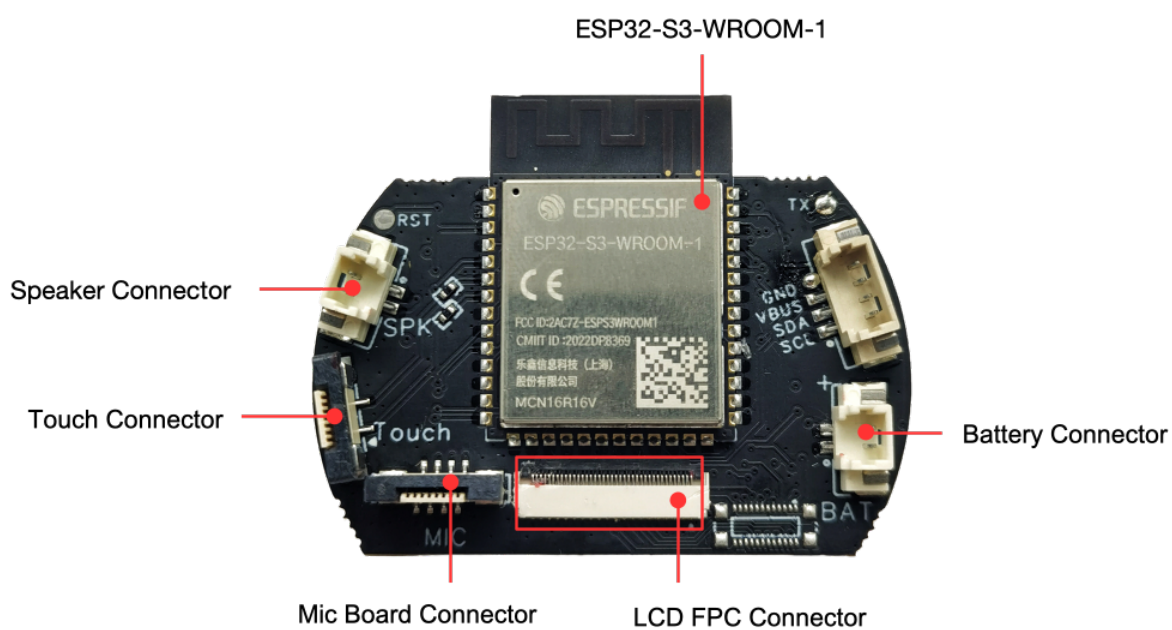

Fig. 3: ESP-VoCat CoreBoard PCB Front View (Click to enlarge)

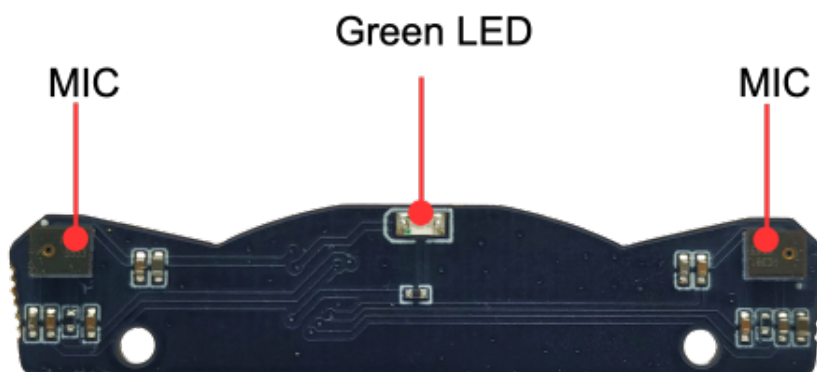

Fig. 4: ESP-VoCat MicBoard PCB Front View (Click to enlarge)

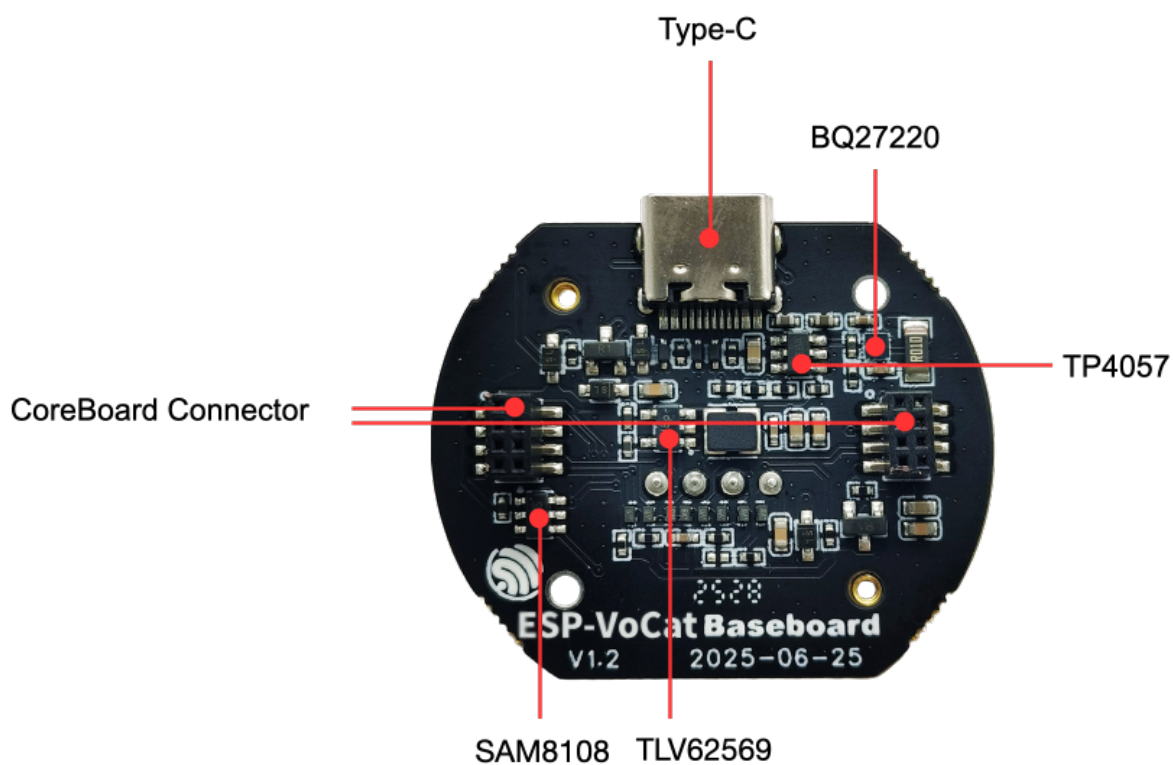

Fig. 5: ESP-VoCat BaseBoard PCB Front View (Click to enlarge)

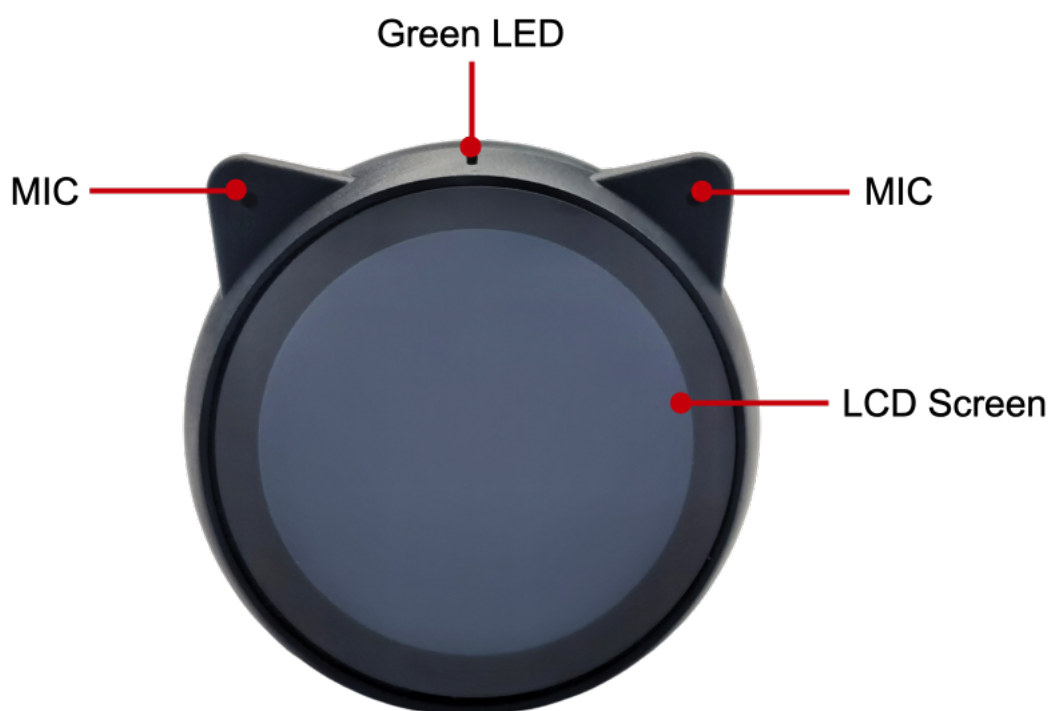

Fig. 6: ESP-VoCat Front View (Click to enlarge)

Main Components	Description
<b>CoreBoard</b>	
ESP32-S3-WROOM-1-N16R16VA	Main controller chip, integrates 16 MB Flash and 16 MB PSRAM, supports 2.4 GHz Wi-Fi and Bluetooth 5 (LE) wireless connectivity.
Battery Connector	Battery connector for connecting 3.7 V lithium battery, top is positive, bottom is negative.
LCD FPC Connector	For connecting 1.85-inch circular LCD screen with 360 x 360 resolution. For detailed parameters, please refer to the <a href="#">Display Specification</a> .
MicBoard Connector	MicBoard PCB connector, connects dual microphone array and status indicator LED.
Touch Connector	Touch connector for connecting touch copper foil to achieve touch interaction functionality.
Speaker Connector	2-wire speaker connector for connecting built-in 3 W speaker.
<b>MicBoard</b>	
Green LED	Green LED indicator.
MIC (Microphone Array)	Dual LMA3729T381-OY3S microphone array, supports local voice wake-up and sound source localization functionality.
<b>BaseBoard</b>	
BQ27220 (Battery Management Chip)	Battery management chip for battery level detection, charging management, and power status monitoring.
TP4057 (Lithium Battery Charging Chip)	Lithium battery charging chip for charging lithium batteries with 250 mA charging current.
CoreBoard Connector	CoreBoard PCB connector, connects core board with base board.
TIV62569 (DCDC Chip)	Buck converter chip for converting 5 V power to 3.3 V power, providing stable power supply for the system.
SAM8108 (Power Control Chip)	Power control chip for controlling device power on/off. Single click of POWER button can toggle power on/off status.
Type-C (USB-C Interface)	USB-C interface for power supply, programming download, and debugging, supports charging lithium batteries.

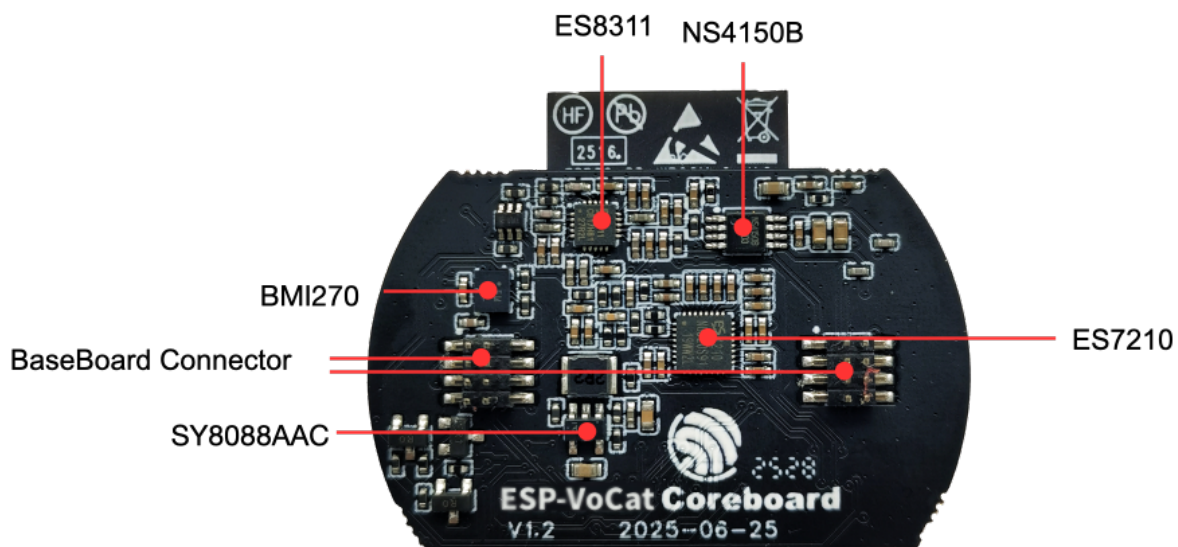

Fig. 7: ESP-VoCat CoreBoard PCB Back View (Click to enlarge)

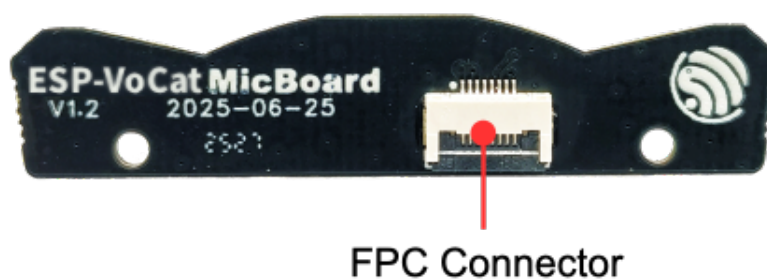

Fig. 8: ESP-VoCat MicBoard PCB Back View (Click to enlarge)

The following introduces the main components on the back PCB in clockwise order. For user convenience, we have also labeled these components or interfaces on the ESP-VoCat housing.

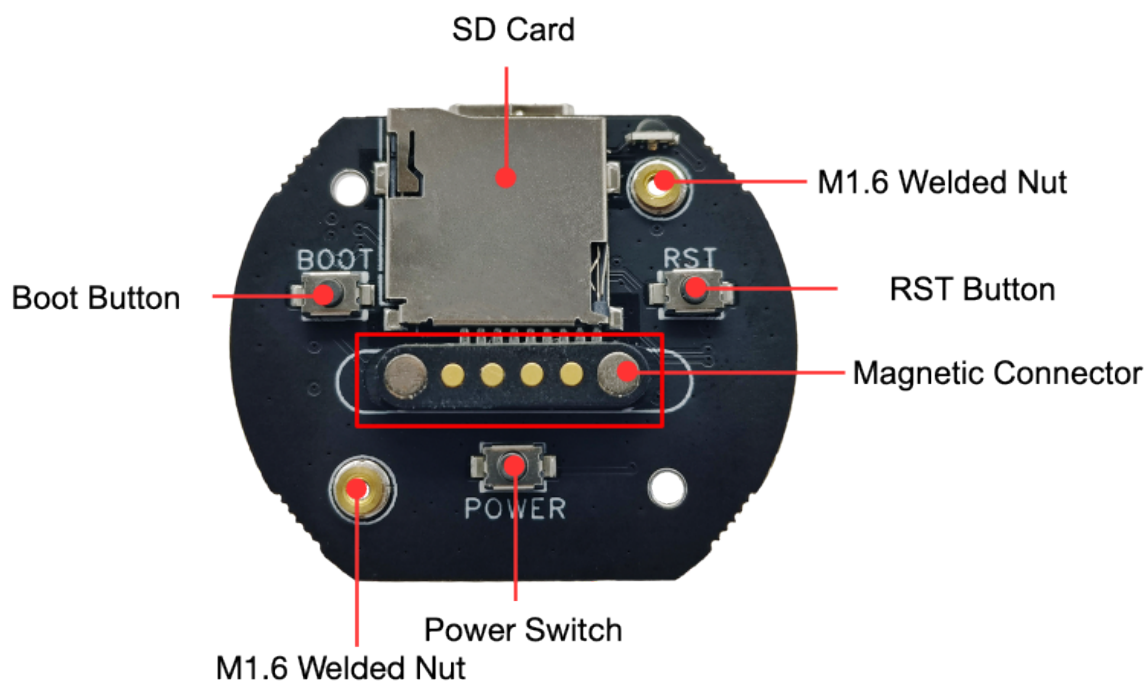

Fig. 9: ESP-VoCat BaseBoard PCB Back View (Click to enlarge)

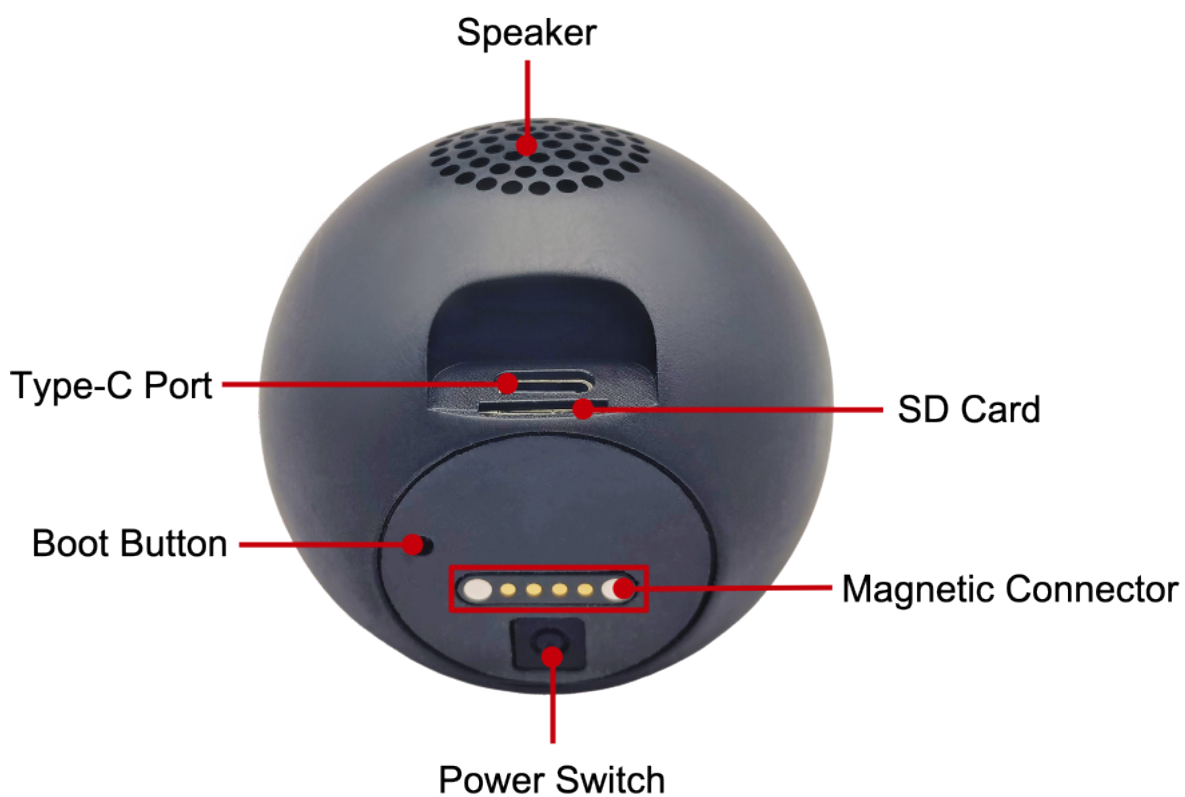

Fig. 10: ESP-VoCat Back View (Click to enlarge)

Main Components	Description
<b>CoreBoard</b>	
NS4150B (Class D Amplifier)	Ultra-low EMI, filterless, 3W mono Class D audio amplifier.
ES7210 (Audio Decoder Chip)	High-performance 4-channel audio decoder chip, supports I2S/PDM/TDM data ports.
SY8088AAC (DCDC chip)	Buck converter chip used to convert a 5 V power supply to a 3.3 V power supply, providing stable power for the Codec.
BaseBoard Connector	Base board connector for connecting base board with CoreBoard.
BMI270 (IMU - Inertial Measurement Unit)	6-axis intelligent low-power inertial measurement unit for high-performance applications.
ES8311 (Audio Codec Chip)	Low-power mono audio codec with high-performance multi-bit Delta-Sigma audio ADC and DAC.
<b>MicBoard</b>	
FPC Connector	Connects MicBoard with CoreBoard FPC connector.
<b>BaseBoard</b>	
M1.6 Welded Nut	For fixing main board to housing.
RST Button (Reset Button)	For resetting the main board.
Magnetic Connector	For functional expansion, provides a serial port and 5 V power interface, can connect to rotating base and other devices.
POWER Switch	For controlling device power on/off. Single click of POWER button can toggle power on/off status.
BOOT Button	When powering on, hold this button to enter download mode.
SD Card Slot	Supports up to 32 GB microSD card slot for storing audio, images, videos, and other data.

### Start Application Development

Before powering on, please ensure ESP-VoCat is intact and undamaged.

### Required Hardware

- ESP-VoCat
- USB data cable
- Computer (Windows, Linux, or macOS)

---

**Note:** Be sure to use an appropriate USB cable. Some cables are for charging only and do not provide the needed data lines nor work for programming the boards.

---

**Hardware Setup** Use a USB data cable to connect ESP-VoCat to your computer through the Type-C (USB-C Interface) for firmware burning, debugging, and power supply.

**Software Setup** Please proceed to [ESP-IDF Get Started](#) to set up the development environment and flash an application example onto your board.

---

**Note:** In most cases, USB drivers required to operate the board are already included in Windows, Linux, and macOS operating systems. Some additional port access or security configuration may be required depending on your OS. In case of issues, please check documentation on [how to establish serial connection](#) with the board. The documentation also includes links to USB drivers applicable to boards produced by Espressif.

---

Espressif provides Board Support Packages (BSPs) for various Espressif boards that help you initialize and use key onboard peripherals, such as LCD displays, audio chips, buttons, and LEDs, more easily and efficiently. For a complete list of supported boards, please visit [esp-bsp](#).

Development board application examples are stored in the [esp-brookesia](#) project.

## 4.1.2 Hardware Reference

### Block Diagram

The block diagram below shows the components of ESP-VoCat and their interconnections.

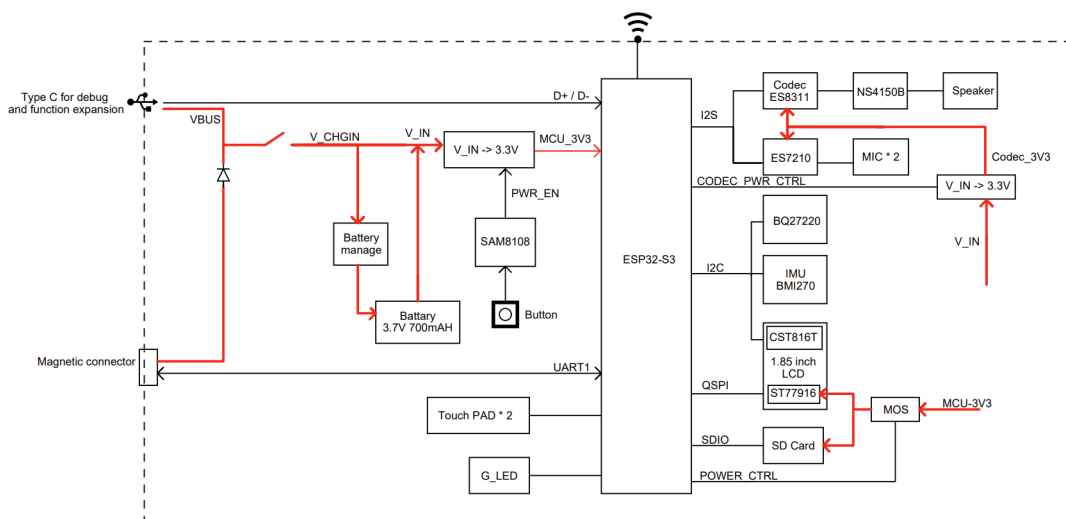

Fig. 11: ESP-VoCat Block Diagram (Click to enlarge)

### Power Supply Options

There are three mutually exclusive ways to provide power to the board:

1. Power through Type-C (USB-C Interface)  
When using this method, connect the device's Type-C interface using a USB Type-C data cable. If a lithium battery is installed, you need to press the POWER button to enable power supply to the device.
2. Power through Magnetic Connector  
When using this method, connect the device to the corresponding magnetic connector base to power the device. If a lithium battery is installed, you need to press the POWER button to enable power supply to the device.
3. Power through Battery  
The device has an integrated 3.7 V lithium battery. Press the POWER button to power the device.

Any of the above external power supply methods can charge the internal lithium battery.

### Type-C Interface

### Magnetic Connector Interface

### LCD Interface

Please note that the CN3 interface is reserved for other screen compatibility and is currently not enabled.

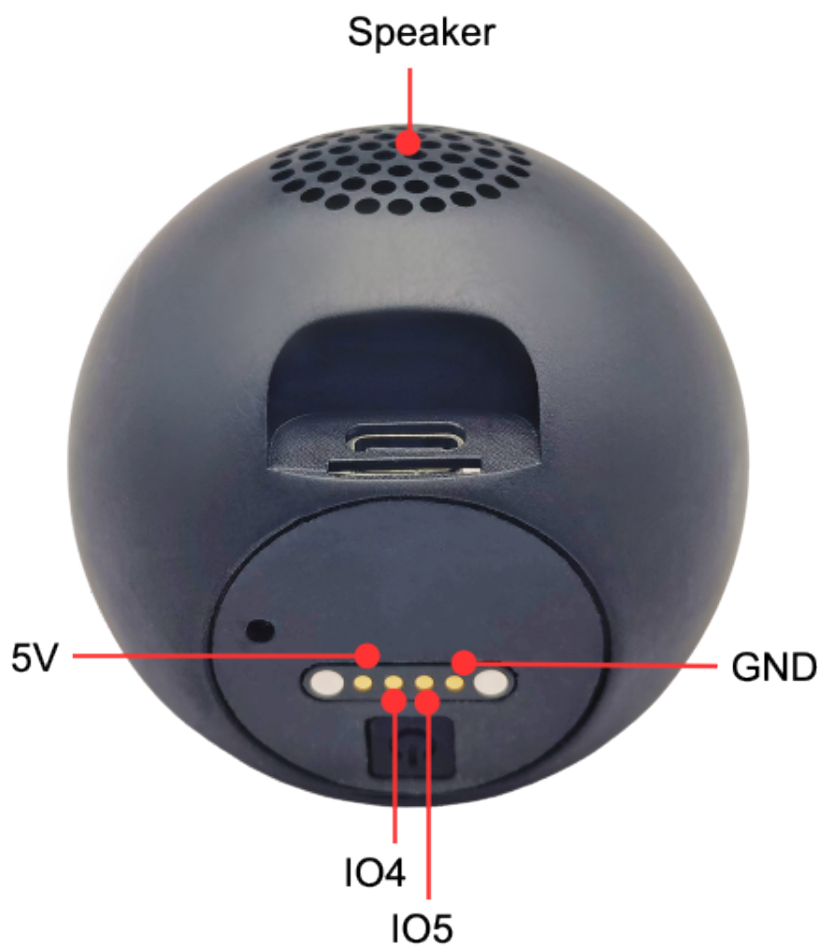

Fig. 12: Magnetic Connector (Click to enlarge)

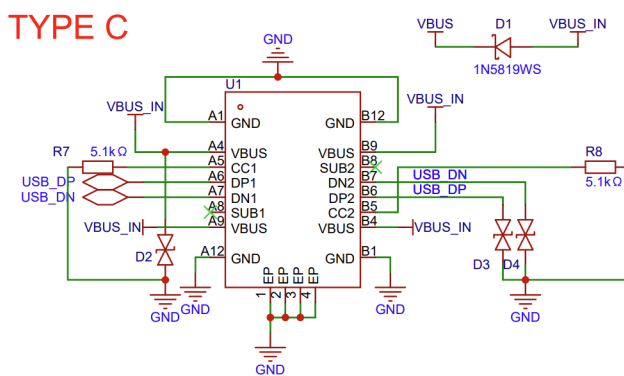

Fig. 13: Type-C Interface Circuit Diagram (Click to enlarge)

### Magnetic connector

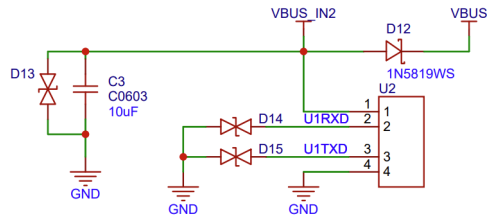

Fig. 14: Magnetic Connector Interface Circuit Diagram (Click to enlarge)

### LCD

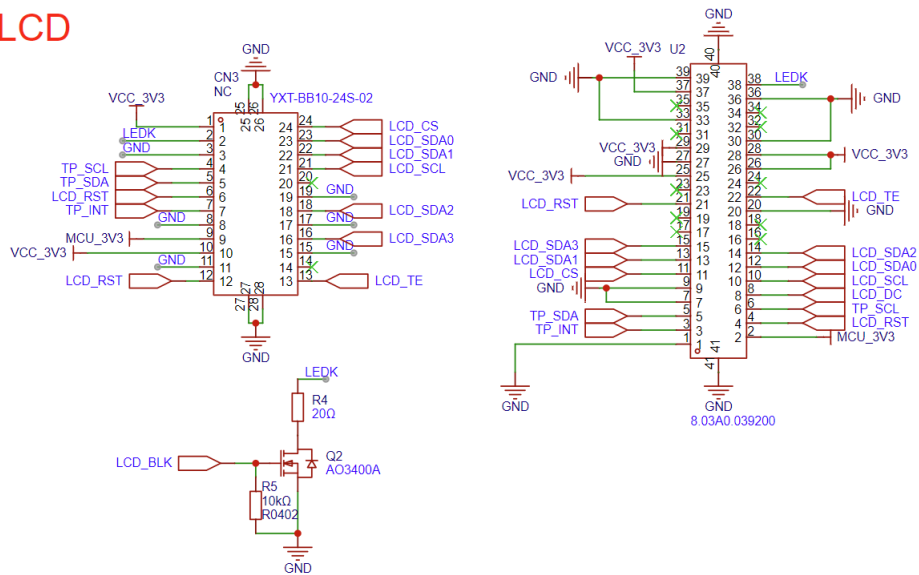

Fig. 15: LCD Interface Circuit Diagram (Click to enlarge)

The U2 interface is the officially used LCD screen interface. The screen model used by this development board is ST77916, LCD: 1.85" , 360 x 360, ST77916, QSPI Interface. LCD\_BLK (GPIO44) can be used to control screen backlight.

### SD Card Interface

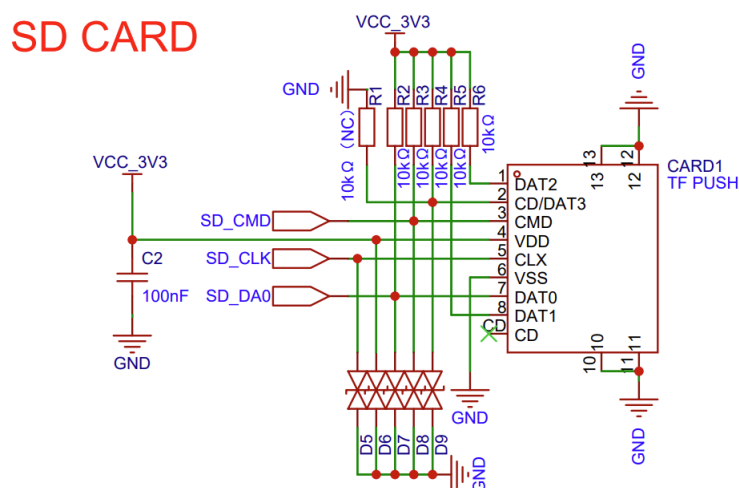

Fig. 16: SD Card Interface Circuit Diagram (Click to enlarge)

Please note that the SD card interface supports:

- 1-wire SD bus configuration
- Communication through SDIO protocol

### Power Switch Circuit

## POWER ON/OFF MANAGEMENT

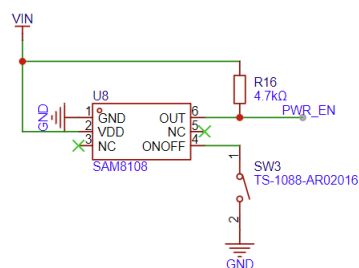

Fig. 17: Power Switch Circuit Diagram (Click to enlarge)

### Charging Circuit

### Microphone Interface

## 4.1.3 Hardware Revision Details

## BAT CHARGE

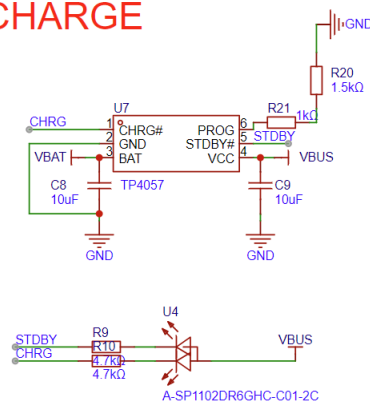

Fig. 18: Charging Circuit Diagram (Click to enlarge)

## BAT MANAGEMENT

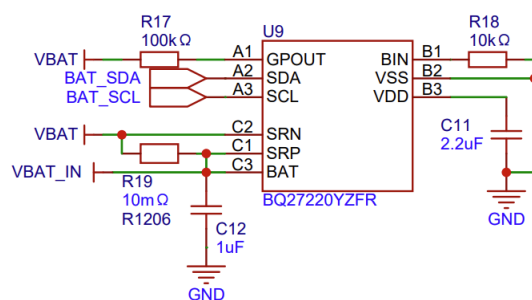

Fig. 19: Battery Management Circuit Diagram (Click to enlarge)

## MIC CONNECT

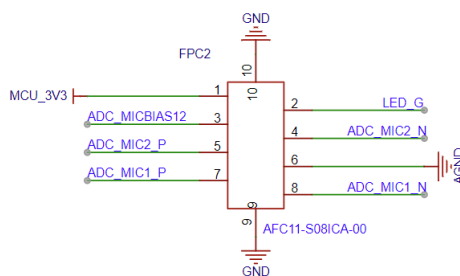

Fig. 20: Microphone Interface Circuit Diagram (Click to enlarge)

## ESP-VoCat v1.2

- The following pins have been reassigned:
  - U1RXD: Changed from IO5 to IO4
  - U1TXD: Changed from IO6 to IO5
  - I2S\_DI: Changed from IO15 to IO3
  - PA\_CTRL: Changed from IO4 to IO15
  - LCD\_RST\_CTRL: Changed from IO3 to IO47
- TOUCH interface increased from 1 to 2 for sliding touch sensing:
  - TOUCH\_PAD1: IO6
  - TOUCH\_PAD2: IO7
- Added CODEC power control:
  - CODEC\_PWR\_CTRL: IO48
- Added IIC expansion interface:
  - Added HC-1.25-4PLT interface: Exposes VIN, I2C\_SDA, I2C\_SCL, and GND

## ESP-VoCat v1.0

- *Initial Release*

### 4.1.4 Related Documents

- [ESP-VoCat V1.2 Schematic \(PDF\)](#)
- [ESP-VoCat V1.2 PCB Layout \(PDF\)](#)
- [Display Specification \(PDF\)](#)
- [User Guide \(HTML\)](#)

## ESP-VoCat v1.0

---

**Note:** Please check the silkscreen version number on the mainboard to confirm your development board version. For v1.0 version development boards, please refer to the current user guide; for v1.2 version development boards, please refer to [ESP-VoCat v1.2](#).

---

This guide will help you get started with ESP-VoCat quickly and provide detailed information about this development board.

ESP-VoCat is an intelligent AI development kit. It is suitable for voice interaction products that require large model capabilities, such as toys, smart speakers, and smart central control systems. The device is equipped with a 1.85-inch QSPI circular touch screen, dual microphone array, and supports offline voice wake-up and sound source localization algorithms. Combined with the large model capabilities provided by OpenAI, Xiaozhi AI, Gemini, etc., ESP-VoCat can achieve full-duplex voice interaction, multimodal recognition, and intelligent agent control, providing a solid foundation for developers to create complete edge-side AI application experiences.

ESP-VoCat's main controller uses the Espressif ESP32-S3-WROOM-2-N32R16V module, supporting 2.4 GHz Wi-Fi and Bluetooth 5 (LE) wireless connectivity. For storage, the entire device has 16 MB PSRAM and 32 MB Flash storage space, and is also equipped with a microSD card slot that can support up to 32 GB, meeting the needs of voice interaction and multimedia processing. It features a 1.85-inch circular touch screen (360 × 360 resolution) with ESP32-S3 native touch sensors, providing an intuitive and rich interactive experience.

For audio, ESP-VoCat has a built-in 3W speaker and dual microphone array, supporting local voice wake-up and sound source localization. The power system is compatible with 5 V DC and 3.7 V lithium battery power supply. Additionally, it integrates a USB-C interface for power supply and programming download, while reserving a Pogopin interface for convenient functional expansion.

The document consists of the following major sections:



Fig. 21: ESP-VoCat Front View (Click to enlarge)



Fig. 22: ESP-VoCat Back View (Click to enlarge)

- *Getting Started*: Overview of the board and hardware/software setup instructions to get started.
- *Hardware Reference*: More detailed information about the board's hardware.
- *Hardware Revision Details*: Hardware revision history and known issues (if any) of the board.
- *Related Documents*: Links to related documentation.

**Getting Started** This section provides a brief introduction of ESP-VoCat, instructions on how to do the initial hardware setup and how to flash firmware onto it.

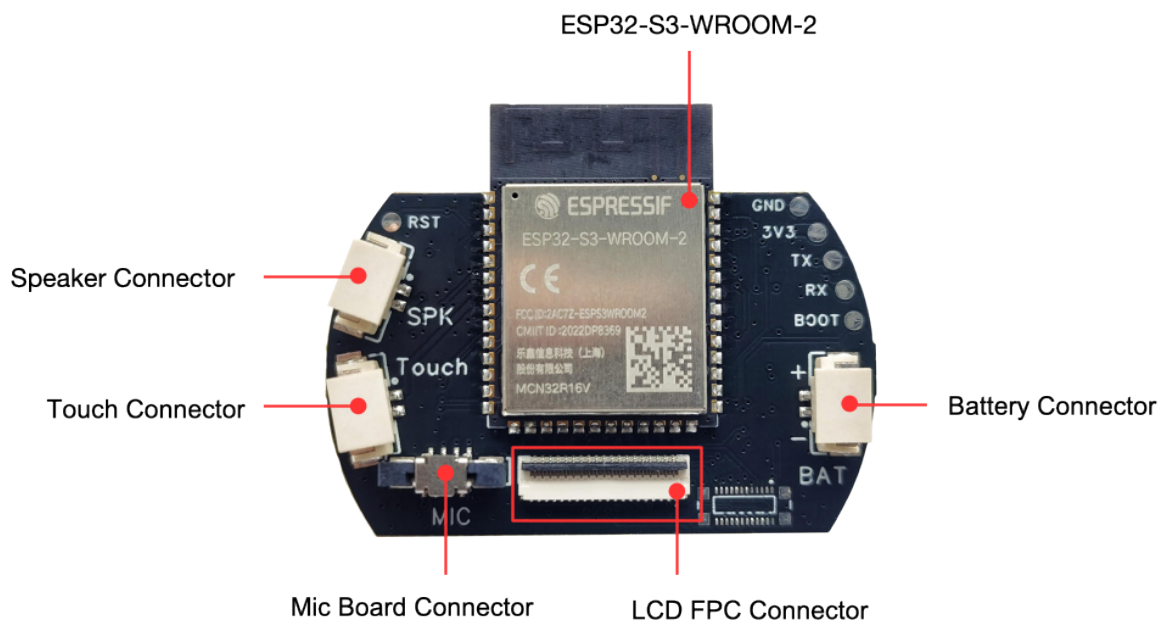

Fig. 23: ESP-VoCat CoreBoard PCB Front View (Click to enlarge)



Fig. 24: ESP-VoCat MicBoard PCB Front View (Click to enlarge)

**Description of Components** The following introduces the main components on the front PCB in clockwise order. For user convenience, we have also labeled these components or interfaces on the ESP-VoCat housing.

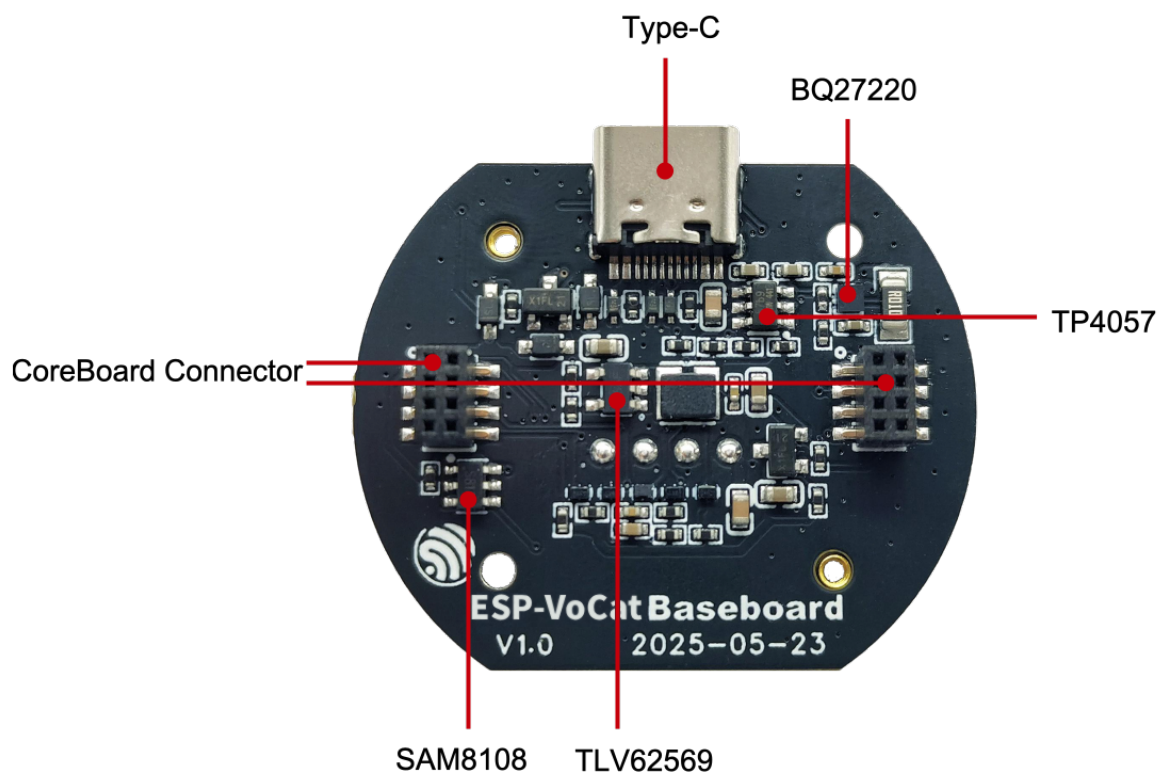

Fig. 25: ESP-VoCat BaseBoard PCB Front View (Click to enlarge)

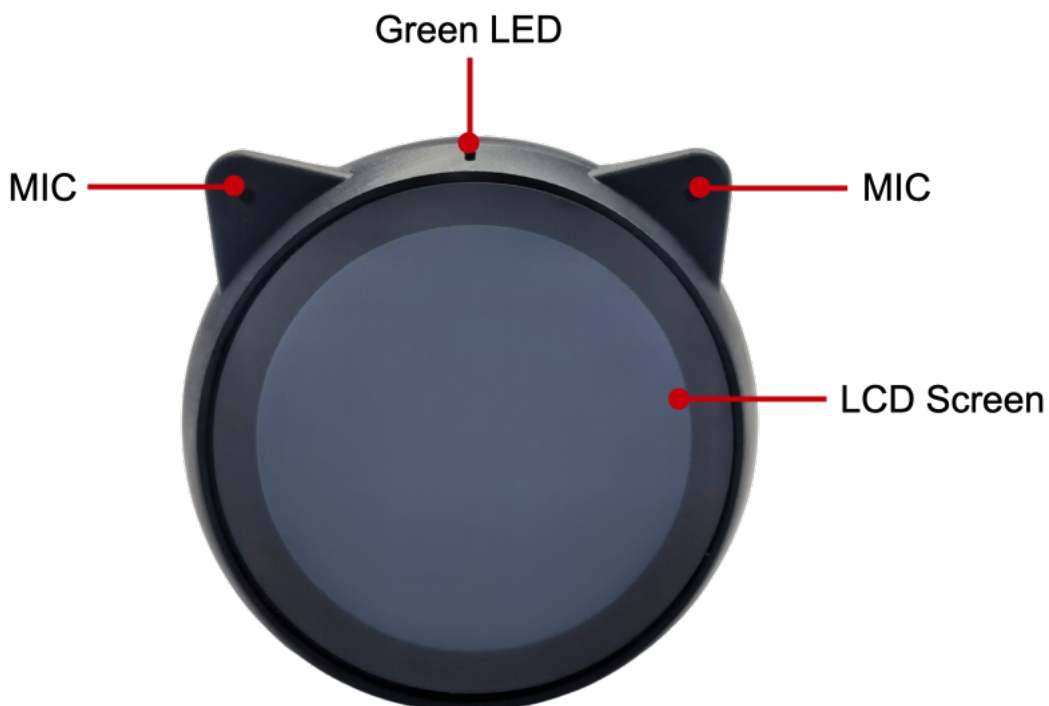

Fig. 26: ESP-VoCat Front View (Click to enlarge)

Main Components	Description
<b>CoreBoard</b>	
ESP32-S3-WROOM-2-N32R16V	Main controller chip, integrates 32 MB Flash and 16 MB PSRAM, supports 2.4 GHz Wi-Fi and Bluetooth 5 (LE) wireless connectivity.
Battery Connector	Battery connector for connecting 3.7 V lithium battery, top is positive, bottom is negative.
LCD FPC Connector	For connecting 1.85-inch circular LCD screen with 360 x 360 resolution. For detailed parameters, please refer to the <a href="#">Display Specification</a> .
MicBoard Connector	MicBoard PCB connector, connects dual microphone array and status indicator LED.
Touch Connector	Touch connector for connecting touch copper foil to achieve touch interaction functionality.
Speaker Connector	2-wire speaker connector for connecting built-in 3 W speaker.
<b>MicBoard</b>	
Green LED	Green LED indicator.
MIC (Microphone Array)	Dual LMA3729T381-OY3S microphone array, supports local voice wake-up and sound source localization functionality.
<b>BaseBoard</b>	
BQ27220 (Battery Management Chip)	Battery management chip for battery level detection, charging management, and power status monitoring.
TP4057 (Lithium Battery Charging Chip)	Lithium battery charging chip for charging lithium batteries with 250 mA charging current.
CoreBoard Connector	CoreBoard PCB connector, connects core board with base board.
TIV62569 (DCDC Chip)	Buck converter chip for converting 5 V power to 3.3 V power, providing stable power supply for the system.
SAM8108 (Power Control Chip)	Power control chip for controlling device power on/off. Single click of POWER button can toggle power on/off status.
Type-C (USB-C Interface)	USB-C interface for power supply, programming download, and debugging, supports charging lithium batteries.

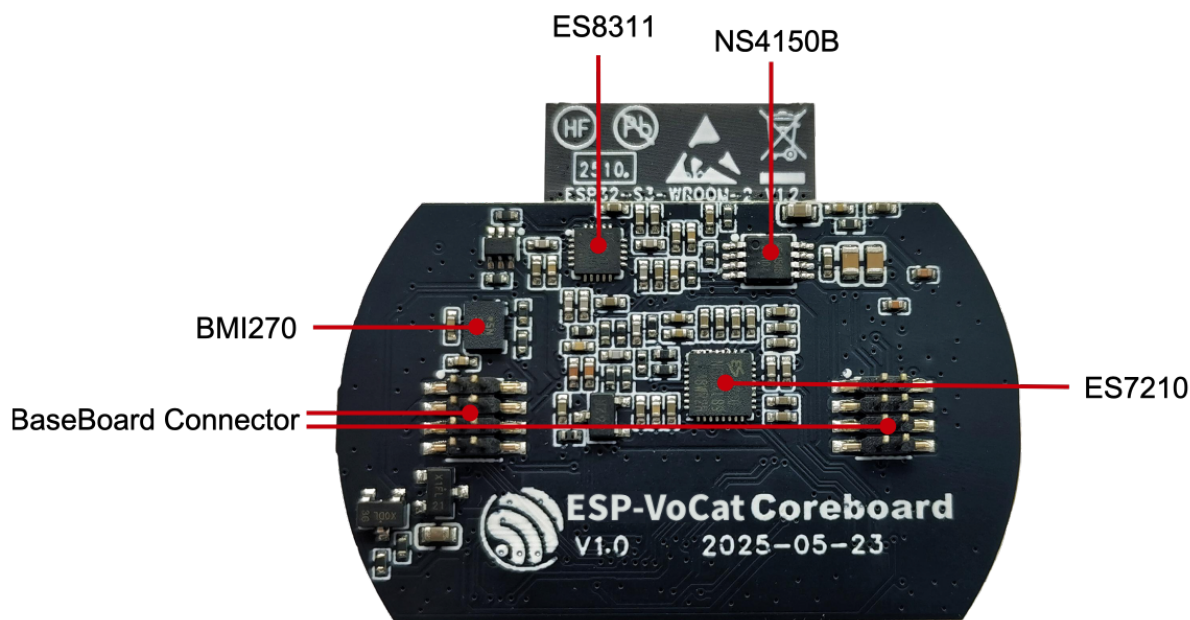

Fig. 27: ESP-VoCat CoreBoard PCB Back View (Click to enlarge)

The following introduces the main components on the back PCB in clockwise order. For user convenience, we have

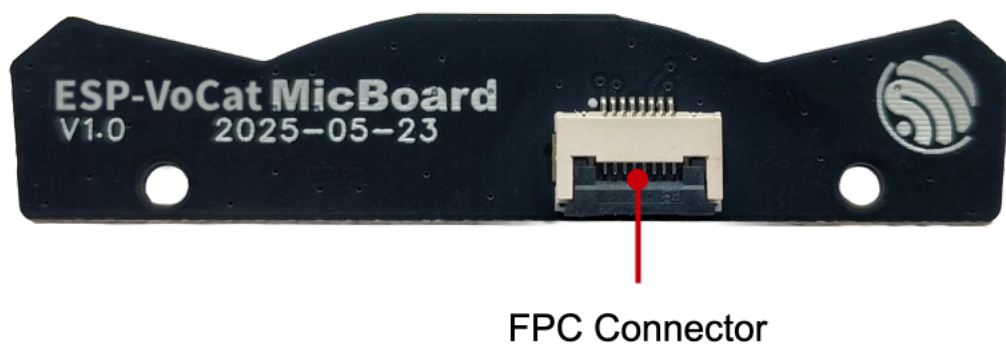

Fig. 28: ESP-VoCat MicBoard PCB Back View (Click to enlarge)

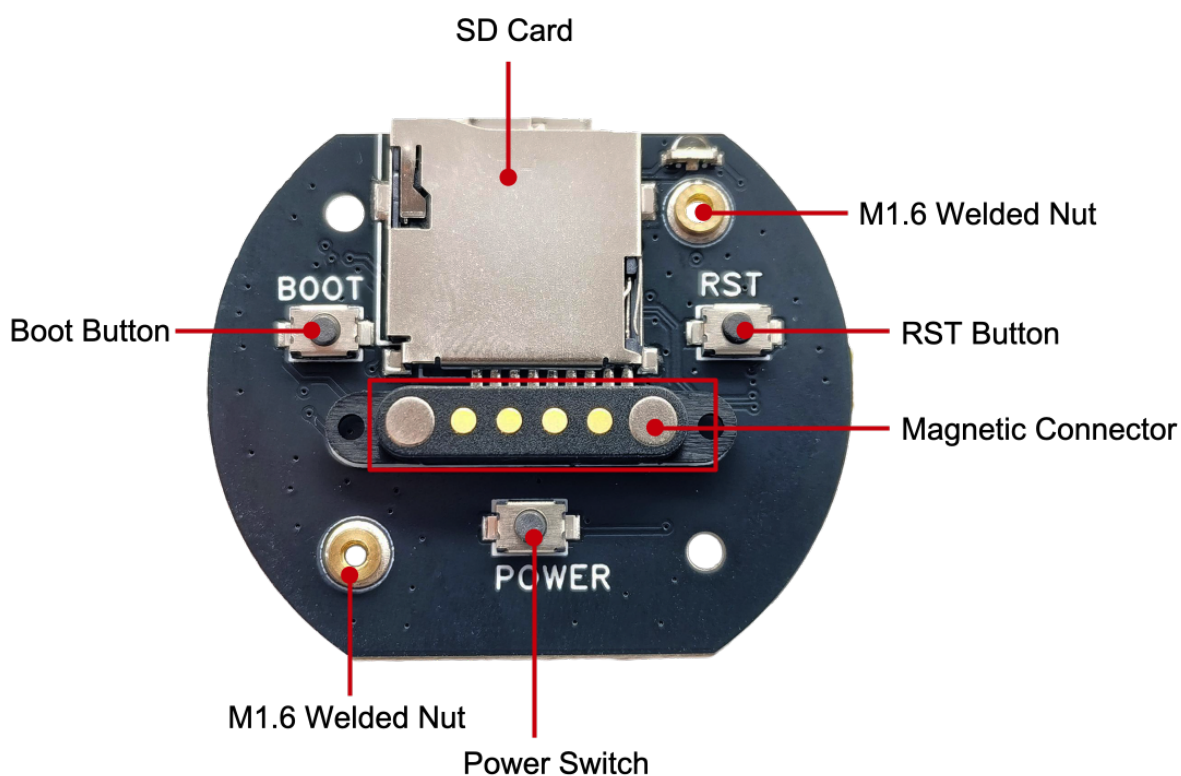

Fig. 29: ESP-VoCat BaseBoard PCB Back View (Click to enlarge)

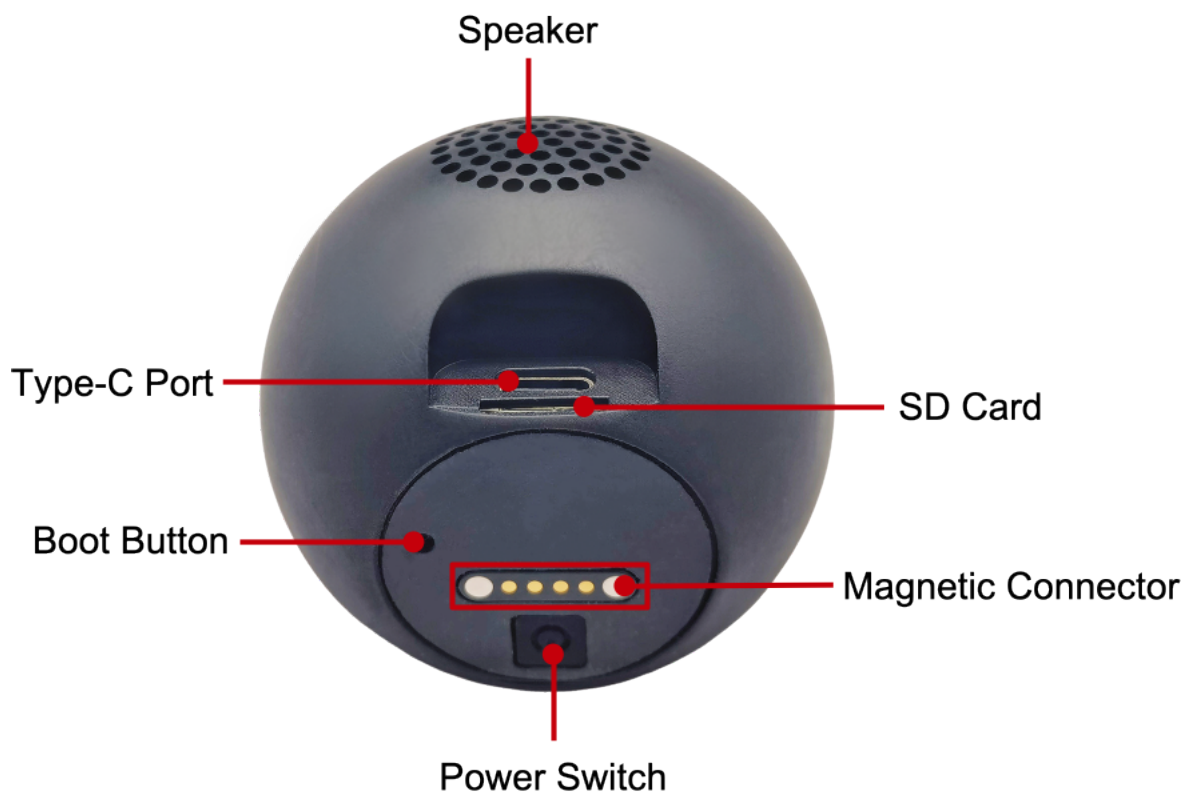

Fig. 30: ESP-VoCat Back View (Click to enlarge)

also labeled these components or interfaces on the ESP-VoCat housing.

Main Components	Description
<b>CoreBoard</b>	
NS4150B (Class D Amplifier)	Ultra-low EMI, filterless, 3W mono Class D audio amplifier.
ES7210 (Audio Decoder Chip)	High-performance 4-channel audio decoder chip, supports I2S/PDM/TDM data ports.
BaseBoard Connector	Base board connector for connecting base board with CoreBoard.
BMI270 (IMU - Inertial Measurement Unit)	6-axis intelligent low-power inertial measurement unit for high-performance applications.
ES8311 (Audio Codec Chip)	Low-power mono audio codec with high-performance multi-bit Delta-Sigma audio ADC and DAC.
<b>MicBoard</b>	
FPC Connector	Connects MicBoard with CoreBoard FPC connector.
<b>BaseBoard</b>	
M1.6 Welded Nut	For fixing main board to housing.
RST Button (Reset Button)	For resetting the main board.
Magnetic Connector	For functional expansion, provides a serial port and 5 V power interface, can connect to rotating base and other devices.
POWER Switch	For controlling device power on/off. Single click of POWER button can toggle power on/off status.
BOOT Button	When powering on, hold this button to enter download mode.
SD Card Slot	Supports up to 32 GB microSD card slot for storing audio, images, videos, and other data.

**Start Application Development** Before powering on, please ensure ESP-VoCat is intact and undamaged.

## Required Hardware

- ESP-VoCat
- USB data cable
- Computer (Windows, Linux, or macOS)

**Note:** Be sure to use an appropriate USB cable. Some cables are for charging only and do not provide the needed data lines nor work for programming the boards.

**Hardware Setup** Use a USB data cable to connect ESP-VoCat to your computer through the Type-C (USB-C Interface) for firmware burning, debugging, and power supply.

**Software Setup** Please proceed to [ESP-IDF Get Started](#) to set up the development environment and flash an application example onto your board.

**Note:** In most cases, USB drivers required to operate the board are already included in Windows, Linux, and macOS operating systems. Some additional port access or security configuration may be required depending on your OS. In case of issues, please check documentation on [how to establish serial connection](#) with the board. The documentation also includes links to USB drivers applicable to boards produced by Espressif.

Espressif provides Board Support Packages (BSPs) for various Espressif boards that help you initialize and use key onboard peripherals, such as LCD displays, audio chips, buttons, and LEDs, more easily and efficiently. For a complete list of supported boards, please visit [esp-bsp](#).

Development board application examples are stored in the [esp-brookesia](#) project.

## Hardware Reference

**Block Diagram** The block diagram below shows the components of ESP-VoCat and their interconnections.

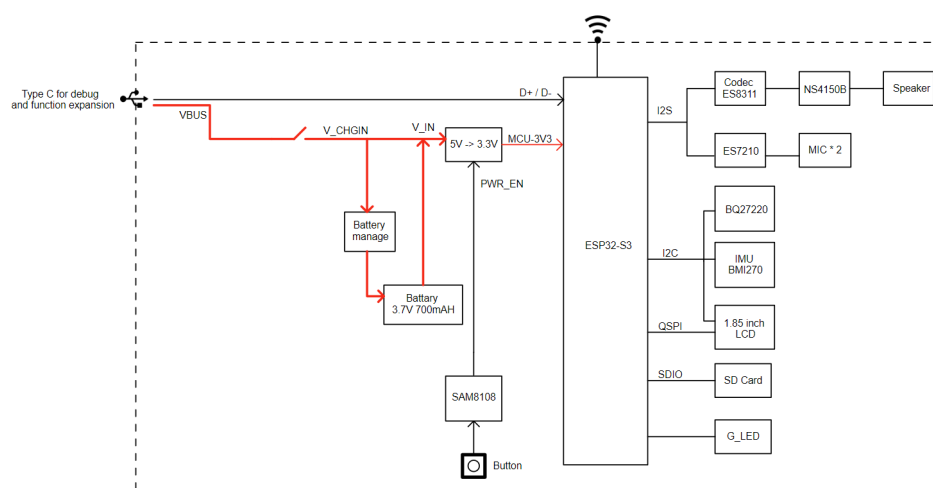

Fig. 31: ESP-VoCat Block Diagram (Click to enlarge)

**Power Supply Options** There are three mutually exclusive ways to provide power to the board:

## 1. Power through Type-C (USB-C Interface)

When using this method, connect the device's Type-C interface using a USB Type-C data cable. If a lithium battery is installed, you need to press the POWER button to enable power supply to the device.

## 2. Power through Magnetic Connector

When using this method, connect the device to the corresponding magnetic connector base to power the device. If a lithium battery is installed, you need to press the POWER button to enable power supply to the device.

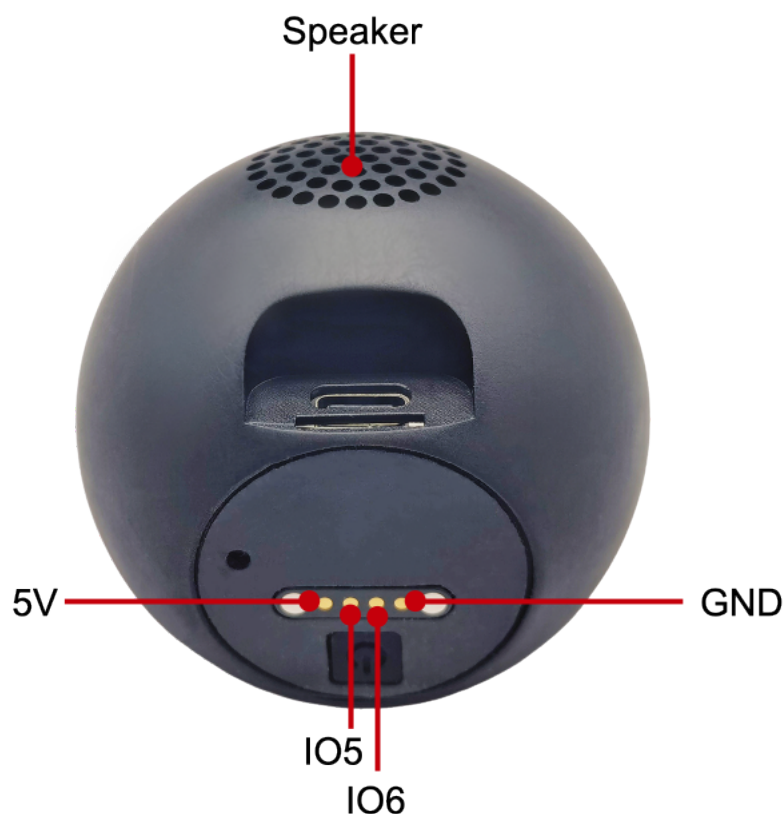

Fig. 32: Magnetic Connector (Click to enlarge)

## 3. Power through Battery

The device has an integrated 3.7 V lithium battery. Press the POWER button to power the device.

Any of the above external power supply methods can charge the internal lithium battery.

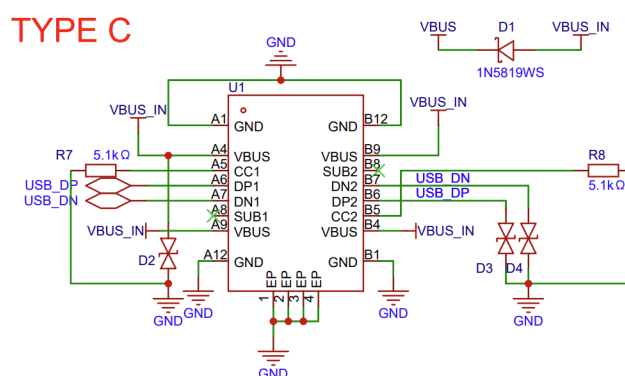

Fig. 33: Type-C Interface Circuit Diagram (Click to enlarge)

## Type-C Interface

### Magnetic connector

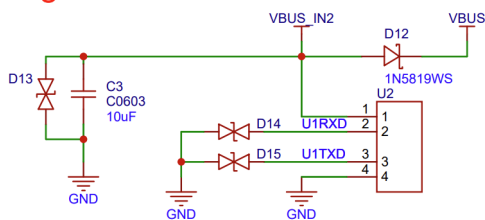

Fig. 34: Magnetic Connector Interface Circuit Diagram (Click to enlarge)

## Magnetic Connector Interface

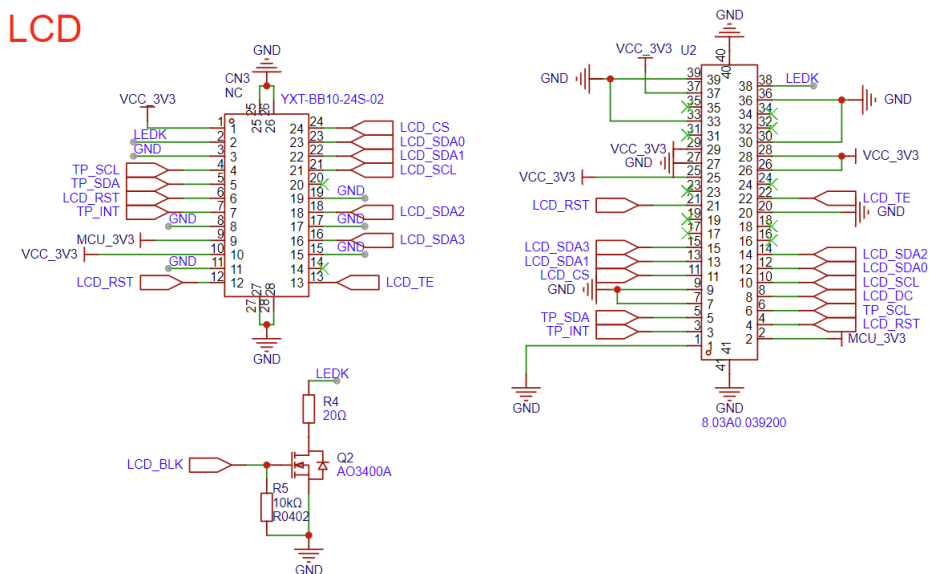

Fig. 35: LCD Interface Circuit Diagram (Click to enlarge)

**LCD Interface** Please note that the CN3 interface is reserved for other screen compatibility and is currently not enabled.

The U2 interface is the officially used LCD screen interface. The screen model used by this development board is [ST77916](#), LCD: 1.85" , 360 x 360, ST77916, QSPI Interface. LCD\_BLK (GPIO44) can be used to control screen backlight.

**SD Card Interface** Please note that the SD card interface supports:

- 1-wire SD bus configuration
- Communication through SDIO protocol

## Power Switch Circuit

## Charging Circuit

## Microphone Interface

## SD CARD

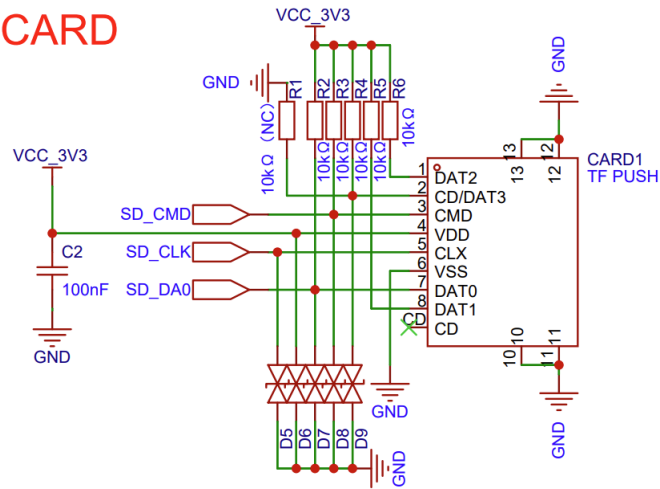

Fig. 36: SD Card Interface Circuit Diagram (Click to enlarge)

## POWER ON/OFF MANAGEMENT

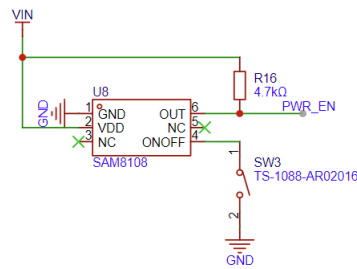

Fig. 37: Power Switch Circuit Diagram (Click to enlarge)

## BAT CHARGE

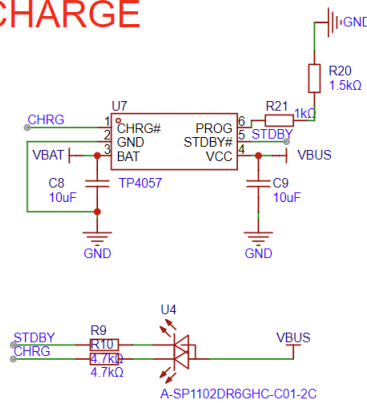

Fig. 38: Charging Circuit Diagram (Click to enlarge)

## BAT MANAGEMENT

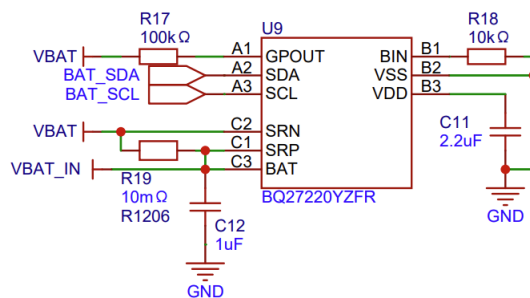

Fig. 39: Battery Management Circuit Diagram (Click to enlarge)

## MIC CONNECT

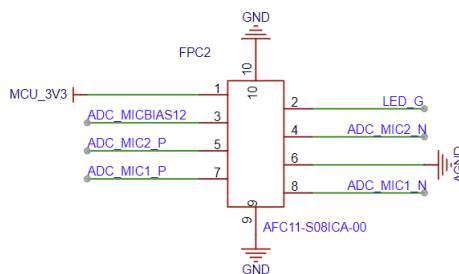

Fig. 40: Microphone Interface Circuit Diagram (Click to enlarge)

**Hardware Revision Details** No historical versions.

#### **Related Documents**

- [ESP-VoCat V1.0 Schematic \(PDF\)](#)
- [ESP-VoCat V1.0 PCB Layout \(PDF\)](#)
- [Display Specification \(PDF\)](#)
- [Replication Tutorial \(HTML\)](#)
- [User Guide \(HTML\)](#)

## Chapter 5

# ESP-DualKey

ESP-DualKey is an intelligent dual-key controller development board based on the ESP32-S3 chip developed by Espressif. It integrates smart home control, Bluetooth keyboard, USB keyboard, and other functions, and can switch between different working modes through physical switches. The development board features dual buttons, RGB lighting effects, battery management, power monitoring, and other functions, providing developers with a complete intelligent button solution.

Application examples for the development board are stored in the [Examples](#) folder.

### 5.1 ESP-DualKey

---

**Note:** Please check the silkscreen version number on the main board to confirm your development board version.

---

This user guide will help you get started with ESP-DualKey and will also provide more in-depth information.

ESP-DualKey is an intelligent dual-key controller development board developed by Espressif based on the ESP32-S3 chip, integrating smart home control, Bluetooth keyboard, USB keyboard and other functions. It can switch between different working modes through physical switches. The development board is equipped with dual buttons, RGB lighting effects, battery management, power monitoring and other functions, providing developers with a complete intelligent button solution.

The ESP-DualKey main controller uses the Espressif ESP32-S3 chip, supporting 2.4 GHz Wi-Fi and Bluetooth 5 (LE) wireless connectivity. In terms of storage, the entire device has 8 MB flash storage space to meet the needs of intelligent button applications. It is equipped with a dual-button matrix and WS2812 RGB lighting effects, providing an intuitive and rich interactive experience.

In terms of power supply, ESP-DualKey supports USB-C power supply and built-in lithium battery power supply, integrating battery management chips and power monitoring functions. In addition, it also integrates a USB-C interface that supports power supply and programming download, while providing multiple working mode switching functions.

The document consists of the following major sections:

- *Getting Started*: Overview of the board and hardware/software setup instructions to get started.
- *Hardware Reference*: More detailed information about the board's hardware.
- *Hardware Revision Details*: Hardware revision history and known issues (if any) of the board.
- *Related Documents*: Links to related documentation.



Fig. 1: ESP-DualKey Front View (Click to enlarge)

---

**Note:** For instructions on using the factory firmware, please refer to [ESP-DualKey User Guide](#).

---

## 5.1.1 Getting Started

This section provides a brief introduction of ESP-DualKey, instructions on how to do the initial hardware setup and how to flash firmware onto it.

### Feature List

The main features of the board are listed below:

#### Button Matrix Configuration:

- 2×1 matrix configuration
- Supports independent button detection
- Supports combination button functions

#### RGB LED Features:

- WS2812 programmable RGB LED
- Supports multiple lighting effect modes
- Supports brightness, hue, and saturation adjustment

#### Mode Switch:

- **Left Position:** Bluetooth keyboard mode
- **Middle Position:** USB keyboard mode
- **Right Position:** Smart home mode (ESP RainMaker)

### Description of Components

The key components of the board are described below. For user convenience, the components or interfaces are also labeled on the housing of ESP-DualKey.

Key Component	Description
<b>Main Controller</b>	
ESP32-S3	Main controller chip supporting 2.4 GHz Wi-Fi and Bluetooth 5 (LE) connectivity, and featuring 8 MB of integrated flash storage.
<b>Interaction</b>	
Dual Buttons	2×1 button matrix, supports independent key detection and combination key functions.
Mode Switch	Three-position switch for toggling between operating modes (Bluetooth keyboard/Wi-Fi Mode/USB keyboard).
<b>RGB Lighting</b>	
WS2812 RGB LED	Programmable RGB LED supporting diverse lighting effects, e.g., heat map, breathing effect, flowing effect.
<b>Power Management</b>	
Lithium Battery Charging Chip	TP4057 lithium battery charging management, supports USB-C charging.
<b>Interfaces</b>	
USB-C Port	USB-C for power, programming/download, debugging, and battery charging.
Two HY2.0-4P Ports	Support auxiliary power output for connecting external sensors.
<b>Other Components</b>	
Battery Voltage Monitoring	Real-time battery voltage and charging status monitoring.
VBUS Monitoring	Monitors USB power status.
Deep-sleep	Supports Deep-sleep mode for energy saving.

### Application Examples

The following application examples are available for ESP-DualKey:

- [ESP-DualKey Smart Button Controller Example](#) - Demonstrates the use of the ESP-DualKey development board as a smart button controller with smart home control, Bluetooth keyboard, and USB keyboard functionalities, allowing for mode switching through physical switches.
- [test\\_apps](#) - Provides unit tests for the esp\_hid component on ESP32 and ESP32-C3 chips, allowing developers to validate the functionality of their code and add new test cases as needed.

For more examples and the latest updates, please refer to the [examples](#) folder.

To explore the application examples or to develop your own, please follow the steps outlined in the [Start Developing Applications](#) section.

### Start Developing Applications

Before powering up your board, please make sure that it is in good condition with no obvious signs of damage.

### Required Hardware

- ESP-DualKey
- USB 2.0 cable (Standard-A to Type-C)
- Computer running Windows, Linux, or macOS

---

**Note:** Please ensure you use an appropriate USB data cable. Some cables can only be used for charging and cannot be used for data transmission and programming.

---

**Hardware Setup** Connect ESP-DualKey with the computer using a USB data cable through the USB-C interface for firmware flashing, debugging and power supply.

**Software Setup** Please proceed to [ESP-IDF Get Started](#) to set up the development environment and flash an application example onto your board.

**Note:** In most cases USB drivers required to operate the board are already included in Windows, Linux, and macOS operating systems. Some additional port access or security configuration may be required depending on your OS. In case of issues please check documentation on [how to establish serial connection](#) with the board. The documentation also includes links to USB drivers applicable to boards produced by Espressif.

Espressif provides Board Support Packages (BSPs) for various Espressif boards that help you initialize and use key onboard peripherals, such as LCD displays, audio chips, buttons, and LEDs, more easily and efficiently. For a complete list of supported boards, please visit [esp-bsp](#).

## 5.1.2 Hardware Reference

### Block Diagram

The block diagram below shows the components of ESP-DualKey and their interconnections.

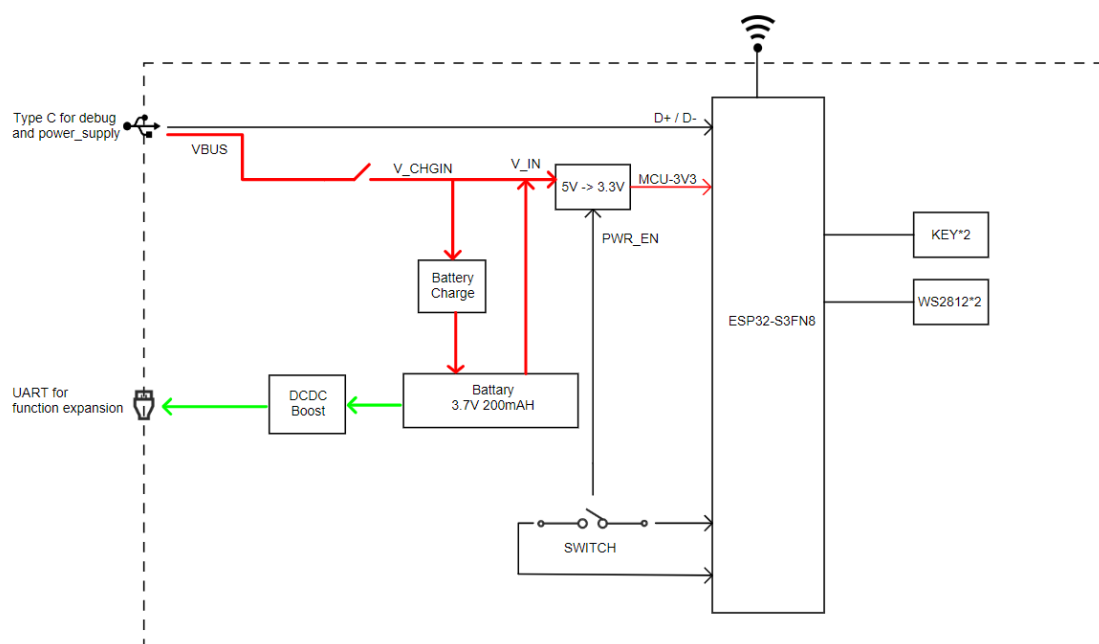

Fig. 2: ESP-DualKey Functional Block Diagram (Click to enlarge)

**Power Supply Options** There are two mutually exclusive ways to provide power to the board:

1. Through USB-C interface power supply  
When using this method for power supply, use a USB Type-C data cable to connect to the USB-C interface on the device.
2. Through built-in lithium battery power supply  
The device has an integrated lithium battery inside, supporting independent power supply operation.

**Mode Switch Circuit** The mode switch circuit diagram of the board is shown below.

## Switch

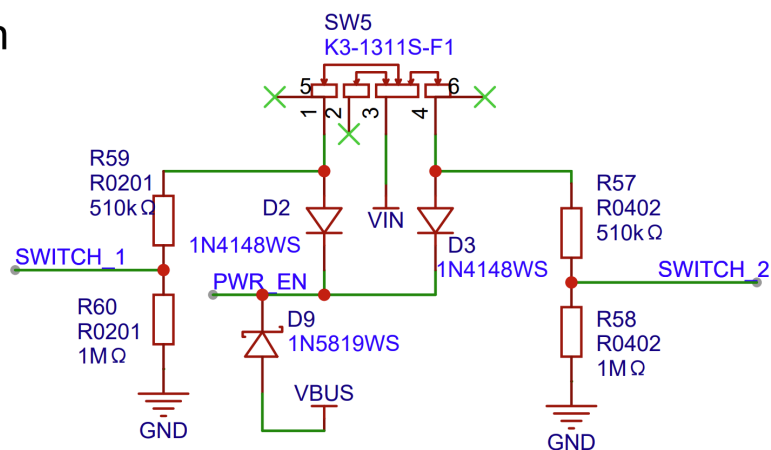

Fig. 3: Mode Switch Circuit Diagram (Click to enlarge)

### 5.1.3 Hardware Revision Details

This is the first revision of this board released.

### 5.1.4 Related Documents

- [ESP-DualKey Schematic \(PDF\)](#)
- [User Guide \(HTML\)](#)



## Chapter 6

# EOL (End of Life) Boards

This section contains user guides for the ESP32-S3 end-of-life development boards and is provided for reference only. While these boards may still be available on the market or used in legacy systems, they no longer receive updates, bug fixes, or official support. It is recommended to switch to newer development boards for better performance and more features.

### 6.1 ESP32-S3-DevKitM-1

---

**Note:** As the ESP32-S3-DevKitM-1 development board offers essentially the same functionality and applications as ESP32-S3-DevKitC-1-N8R8 and ESP32-S3-DevKitC-1U-N8R8, its production has been discontinued. Developers may use ESP32-S3-DevKitC-1-N8R8 or ESP32-S3-DevKitC-1U-N8R8 for software and basic function testing (refer to [ESP32-S3-DevKitC-1 User Guide](#)). This change does not affect the supply of the ESP32-S3-MINI-1/1U modules used on the board.

---

The ESP32-S3-DevKitM-1 is an entry-level development board equipped with either ESP32-S3-MINI-1 or ESP32-S3-MINI-1U, a module named for its small size. This board integrates complete Wi-Fi and Bluetooth® Low Energy functions.

Most of the I/O pins on the module are broken out to the pin headers on both sides of this board for easy interfacing. Developers can either connect peripherals with jumper wires or mount ESP32-S3-DevKitM-1 on a breadboard.

#### 6.1.1 ESP32-S3-DevKitM-1

---

**Note:** As the ESP32-S3-DevKitM-1 development board offers essentially the same functionality and applications as ESP32-S3-DevKitC-1-N8R8 and ESP32-S3-DevKitC-1U-N8R8, its production has been discontinued. Developers may use ESP32-S3-DevKitC-1-N8R8 or ESP32-S3-DevKitC-1U-N8R8 for software and basic function testing (refer to [ESP32-S3-DevKitC-1 User Guide](#)). This change does not affect the supply of the ESP32-S3-MINI-1/1U modules used on the board.

---

This user guide will help you get started with ESP32-S3-DevKitM-1 and will also provide more in-depth information.

The ESP32-S3-DevKitM-1 is an entry-level development board equipped with either ESP32-S3-MINI-1 or ESP32-S3-MINI-1U, a module named for its small size. This board integrates complete Wi-Fi and Bluetooth® Low Energy functions.

Most of the I/O pins on the module are broken out to the pin headers on both sides of this board for easy interfacing. Developers can either connect peripherals with jumper wires or mount ESP32-S3-DevKitM-1 on a breadboard.

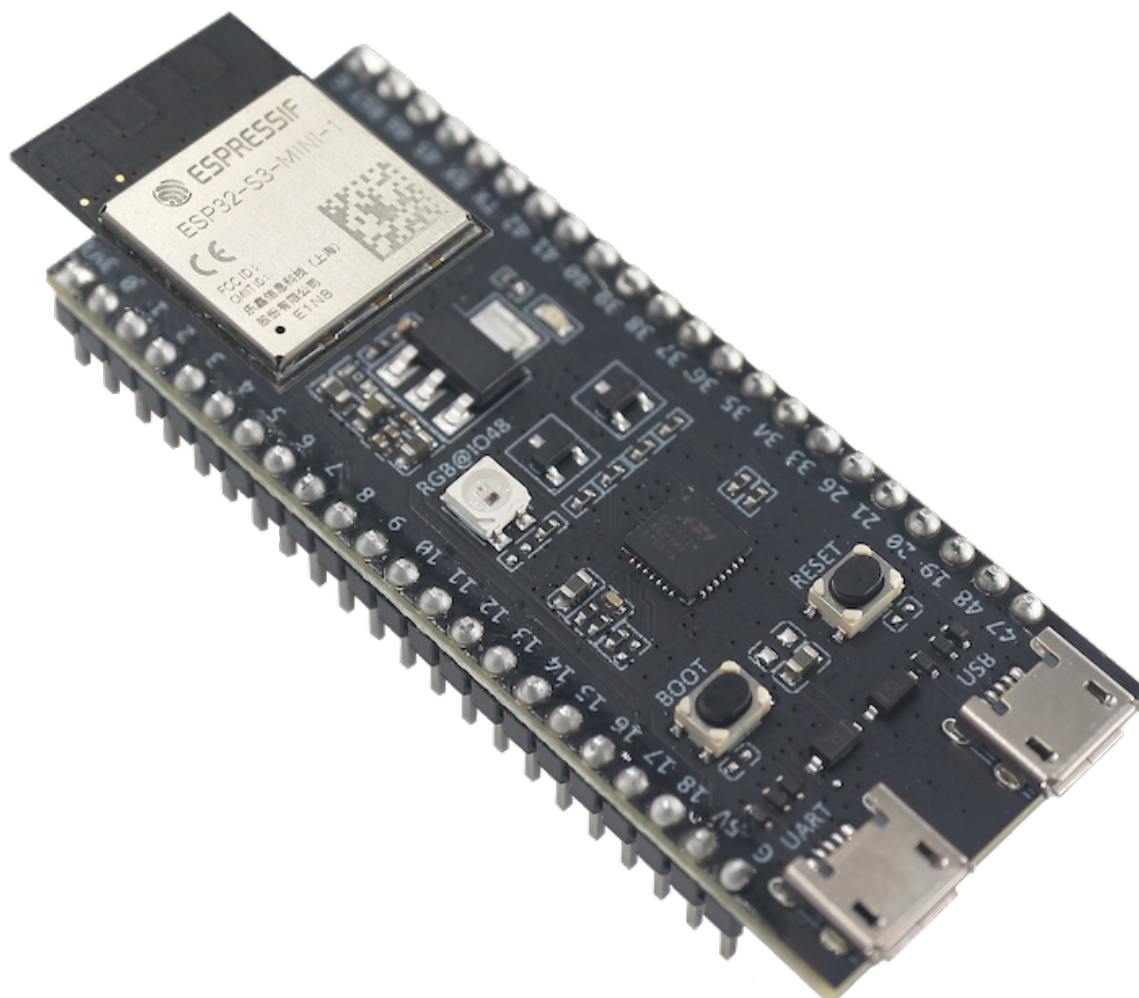

Fig. 1: ESP32-S3-DevKitM-1 with ESP32-S3-MINI-1 Module

The document consists of the following major sections:

- *Getting Started*: Overview of the board and hardware/software setup instructions to get started.
- *Hardware Reference*: More detailed information about the board's hardware.
- *Related Documents*: Links to related documentation.

## Getting Started

This section provides a brief introduction of ESP32-S3-DevKitM-1, instructions on how to do the initial hardware setup and how to flash firmware onto it.

**Description of Components** The key components of the board are described in a counter-clockwise direction, starting from the ESP32-S3-MINI-1/1U module.

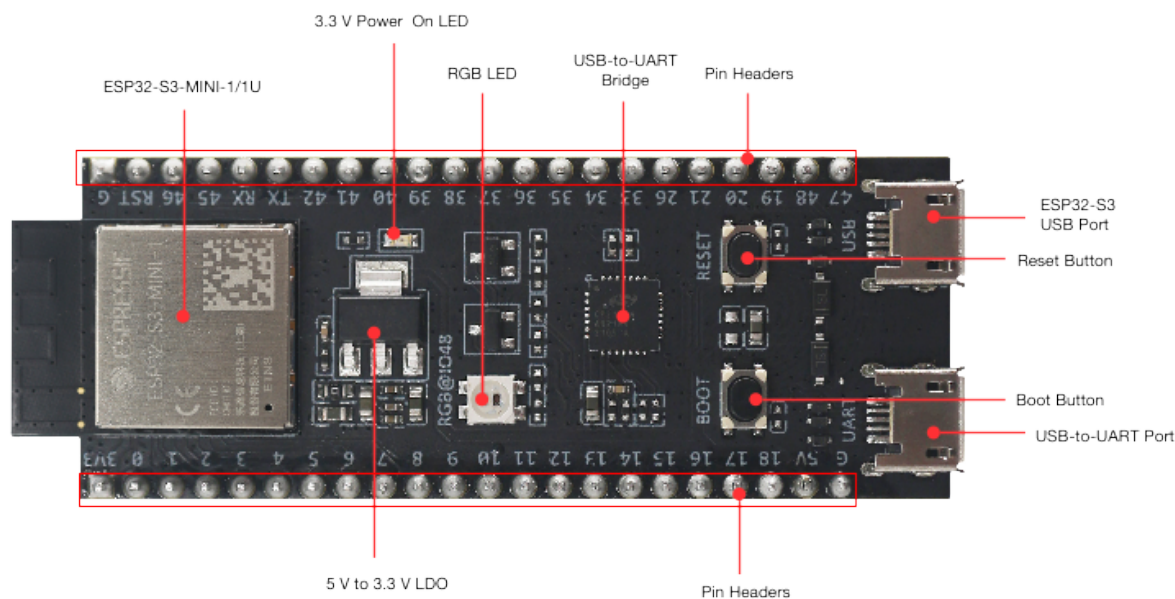

Fig. 2: ESP32-S3-DevKitM-1 - front

Key Component	Description
ESP32-S3-MINI-1/1U	ESP32-S3-MINI-1 and ESP32-S3-MINI-1U are two general-purpose Wi-Fi and Bluetooth Low Energy combo modules that have a rich set of peripherals. ESP32-S3-MINI-1 comes with a PCB antenna. ESP32-S3-MINI-1U comes with an external antenna connector. At the core of the modules is ESP32-S3FN8, a chip equipped with an 8 MB flash. Since flash is packaged in the chip, rather than integrated into the module, ESP32-S3-MINI-1/1U has a smaller package size.
5 V to 3.3 V LDO	Power regulator that converts a 5 V supply into a 3.3 V output.
Pin Headers	All available GPIO pins (except for the SPI bus for flash) are broken out to the pin headers on the board for easy interfacing and programming. For details, please see <a href="#">Header Block</a> .
USB-to-UART Port	A Micro-USB port used for power supply to the board, for flashing applications to the chip, as well as for communication with the chip via the on-board USB-to-UART bridge.
Boot Button	Download button. Holding down <b>Boot</b> and then pressing <b>Reset</b> initiates Firmware Download mode for downloading firmware through the serial port.
Reset Button	Press this button to restart ESP32-S3.
ESP32-S3 USB Port	ESP32-S3 full-speed USB OTG interface, compliant with the USB 1.1 specification. The interface is used for power supply to the board, for flashing applications to the chip, for communication with the chip using USB 1.1 protocols, as well as for JTAG debugging.
USB-to-UART Bridge	Single USB-to-UART bridge chip provides transfer rates up to 3 Mbps.
RGB LED	Addressable RGB LED, driven by GPIO48.
3.3 V Power On LED	Turns on when the USB power is connected to the board.

**Start Application Development** Before powering up your board, please make sure that it is in good condition with no obvious signs of damage.

### Required Hardware

- ESP32-S3-DevKitM-1

- USB 2.0 cable (Standard-A to Micro-B)
- Computer running Windows, Linux, or macOS

**Note:** Be sure to use an appropriate USB cable. Some cables are for charging only and do not provide the needed data lines nor work for programming the boards.

**Hardware Setup** Connect the board with the computer using **USB-to-UART Port** or **ESP32-S3 USB Port**. In subsequent steps, **USB-to-UART Port** will be used by default.

**Software Setup** Please proceed to [Get Started](#), where Section [Installation](#) will quickly help you set up the development environment and then flash an application example onto your board.

### Contents and Packaging

**Retail Orders** If you order a few samples, each board comes in an individual package in either antistatic bag or any packaging depending on your retailer.

For retail orders, please go to <https://www.espressif.com/en/contact-us/get-samples>.

**Wholesale Orders** If you order in bulk, the boards come in large cardboard boxes.

For wholesale orders, please go to <https://www.espressif.com/en/contact-us/sales-questions>.

### Hardware Reference

**Block Diagram** The block diagram below shows the components of ESP32-S3-DevKitM-1 and their interconnections.

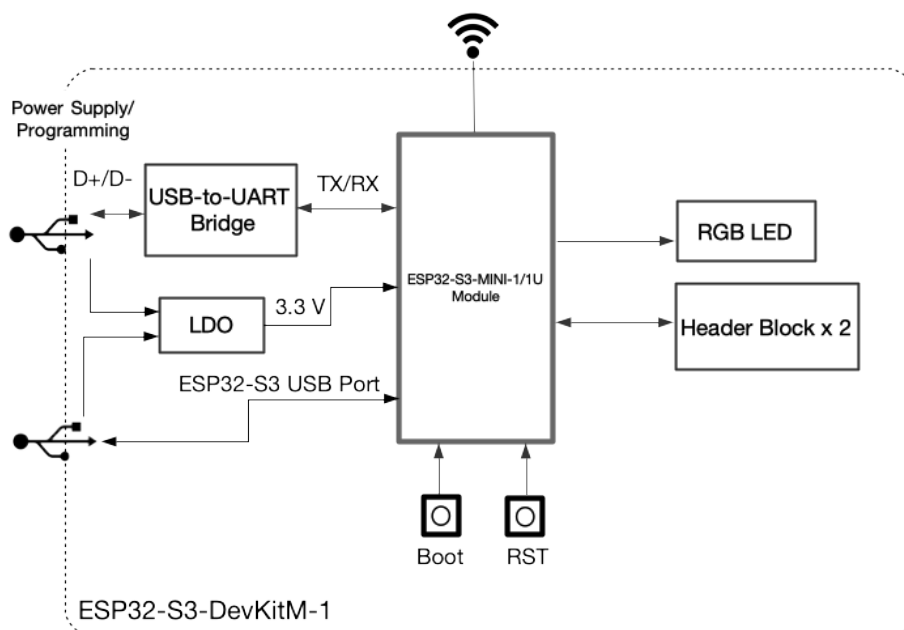

Fig. 3: ESP32-S3-DevKitM-1 (click to enlarge)

**Power Supply Options** There are three mutually exclusive ways to provide power to the board:

- USB-to-UART Port and ESP32-S3 USB Port (either one or both), default power supply (recommended)
- 5V and G (GND) pins
- 3V3 and G (GND) pins

**Header Block** The two tables below provide the **Name** and **Function** of the pins on both sides of the board (J1 and J3). The pin names are shown in *ESP32-S3-DevKitM-1 - front*. The numbering is the same as in the [Board Schematic \(PDF\)](#).

### J1

No.	Name	Type <sup>1</sup>	Function
1	3V3	P	3.3 V power supply
2	0	I/O/T	RTC_GPIO0, GPIO0
3	1	I/O/T	RTC_GPIO1, GPIO1, TOUCH1, ADC1_CH0
4	2	I/O/T	RTC_GPIO2, GPIO2, TOUCH2, ADC1_CH1
5	3	I/O/T	RTC_GPIO3, GPIO3, TOUCH3, ADC1_CH2
6	4	I/O/T	RTC_GPIO4, GPIO4, TOUCH4, ADC1_CH3
7	5	I/O/T	RTC_GPIO5, GPIO5, TOUCH5, ADC1_CH4
8	6	I/O/T	RTC_GPIO6, GPIO6, TOUCH6, ADC1_CH5
9	7	I/O/T	RTC_GPIO7, GPIO7, TOUCH7, ADC1_CH6
10	8	I/O/T	RTC_GPIO8, GPIO8, TOUCH8, ADC1_CH7, SUBSPICS1
11	9	I/O/T	RTC_GPIO9, GPIO9, TOUCH9, ADC1_CH8, FSPIHD, SUBSPIHD
12	10	I/O/T	RTC_GPIO10, GPIO10, TOUCH10, ADC1_CH9, FSPICS0, FSPIIO4, SUBSPICS0
13	11	I/O/T	RTC_GPIO11, GPIO11, TOUCH11, ADC2_CH0, FSPID, FSPIIO5, SUBSPID
14	12	I/O/T	RTC_GPIO12, GPIO12, TOUCH12, ADC2_CH1, FSPICLK, FSPIIO6, SUBSPICLK
15	13	I/O/T	RTC_GPIO13, GPIO13, TOUCH13, ADC2_CH2, FSPIQ, FSPIIO7, SUBSPIQ
16	14	I/O/T	RTC_GPIO14, GPIO14, TOUCH14, ADC2_CH3, FSPIWP, FSPIDQS, SUBSPIWP
17	15	I/O/T	RTC_GPIO15, GPIO15, U0RTS, ADC2_CH4, XTAL_32K_P
18	16	I/O/T	RTC_GPIO16, GPIO16, U0CTS, ADC2_CH5, XTAL_32K_N
19	17	I/O/T	RTC_GPIO17, GPIO17, U1TXD, ADC2_CH6
20	18	I/O/T	RTC_GPIO18, GPIO18, U1RXD, ADC2_CH7, CLK_OUT3
21	5V	P	5 V power supply
22	G	G	Ground

<sup>1</sup> P: Power supply; I: Input; O: Output; T: High impedance.

**J3**

No.	Name	Type	Function
1	G	G	Ground
2	RST	I	EN
3	46	I/O/T	GPIO46
4	45	I/O/T	GPIO45
5	RX	I/O/T	U0RXD, GPIO44, CLK_OUT2
6	TX	I/O/T	U0TXD, GPIO43, CLK_OUT1
7	42	I/O/T	MTMS, GPIO42
8	41	I/O/T	MTDI, GPIO41, CLK_OUT1
9	40	I/O/T	MTDO, GPIO40, CLK_OUT2
10	39	I/O/T	MTCK, GPIO39, CLK_OUT3, SUBSPICS1
11	38	I/O/T	GPIO38, FSPIWP, SUBSPIWP
12	37	I/O/T	SPIDQS, GPIO37, FSPIQ, SUBSPIQ
13	36	I/O/T	SPIIO7, GPIO36, FSPICLK, SUBSPICLK
14	35	I/O/T	SPIIO6, GPIO35, FSPID, SUBSPID
15	34	I/O/T	SPIIO5, GPIO34, FSPICS0, SUBSPICS0
16	33	I/O/T	SPIIO4, GPIO33, FSPIHD, SUBSPIHD
17	26	I/O/T	SPICS1, GPIO26
18	21	I/O/T	RTC_GPIO21, GPIO21
19	20	I/O/T	RTC_GPIO20, GPIO20, U1CTS, ADC2_CH9, CLK_OUT1, USB_D+
20	19	I/O/T	RTC_GPIO19, GPIO19, U1RTS, ADC2_CH8, CLK_OUT2, USB_D-
21	48	I/O/T	SPICLK_N, GPIO48, SUBSPICLK_N_DIFF, RGB LED
22	47	I/O/T	SPICLK_P, GPIO47, SUBSPICLK_P_DIFF

For description of function names, please refer to [ESP32-S3 Datasheet \(PDF\)](#).

ESP32-S3-DevKitM-1

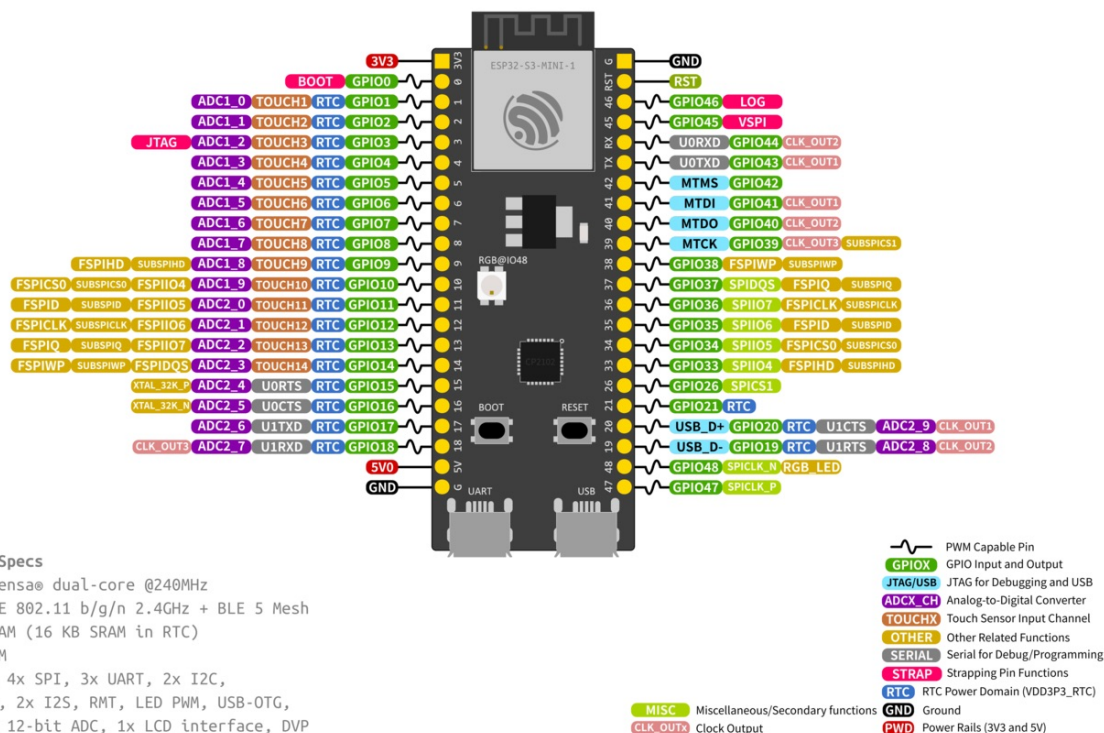

ESP32-S3 Specs  
 32-bit Xtensa® dual-core @240MHz  
 Wi-Fi IEEE 802.11 b/g/n 2.4GHz + BLE 5 Mesh  
 512 KB SRAM (16 KB SRAM in RTC)  
 384 KB ROM  
 45 GPIOs, 4x SPI, 3x UART, 2x I2C,  
 14x Touch, 2x I2S, RMT, LED PWM, USB-OTG,  
 TWAI®, 2x 12-bit ADC, 1x LCD interface, DVP

Fig. 4: ESP32-S3-DevKitM-1 Pin Layout (click to enlarge)

**Pin Layout**

## Hardware Revision Details

This is the first revision of this board released.

## Related Documents

- [ESP32-S3 Datasheet \(PDF\)](#)
- [ESP32-S3-MINI-1 & ESP32-S3-MINI-1U Datasheet \(PDF\)](#)
- [ESP32-S3-DevKitM-1 Schematic \(PDF\)](#)
- [ESP32-S3-DevKitM-1 PCB layout \(PDF\)](#)
- [ESP32-S3-DevKitM-1 Dimensions \(PDF\)](#)
- [ESP32-S3-DevKitM-1 Dimensions source file \(DXF\)](#) - You can view it with [Autodesk Viewer](#) online

For further design documentation for the board, please contact us at [sales@espressif.com](mailto:sales@espressif.com).

## 6.2 ESP32-S3-USB-Bridge

ESP32-S3-USB-Bridge can act as an alternative to USB-to-UART chips like CP210x or debuggers by establishing a bridge between the computer and existing microcontrollers.

### 6.2.1 ESP32-S3-USB-Bridge

This user guide will help you get started with ESP32-S3-USB-Bridge and will also provide more in-depth information.

The document consists of the following sections:

- *Board Overview*: Overview of the board hardware/software
- *Start Application Development*: How to set up hardware/software to develop applications
- *Hardware Reference*: More detailed information about the board's hardware
- *Hardware Revision Details*: This is the first revision of this board released
- *Sample Request*: How to get a sample board
- *Related Documents*: Links to related documentation

### Board Overview

ESP32-S3-USB-Bridge is a development board based on ESP32-S3.

- The [usb\\_wireless\\_bridge](#) example can be used to establish a bridge between a computer and the target chip. It can emulate a USB composite device and supports multiple functions:
  - **USB-to-UART Bridge**: realizes serial data transmission and reception between the computer and the target chip.
  - **JTAG Adapter**: realizes duplex JTAG communication between the computer and the target chip.
  - **MSC Storage Device**: updates firmware by storing the UF2 firmware files in the USB storage device of the board.
  - **Wireless Bridge**: realizes wireless flashing and wireless serial data transmission and reception through ESP-NOW.

The development board also supports a USB Type-A interface that is convenient for replacement.



**Feature List** The main features of the board are listed below:

- **Module Embedded:** ESP32-S3-MINI-1 module with 4 MB flash and 2 MB PSRAM
- **LED Indicators:** on-board WS2812 LED indicator with two serial data LED indicators
- **USB:** on-board USB-to-UART bridge and JTAG adapter, with support for USB download/debugging

**Block Diagram** The block diagram below shows the components of ESP32-S3-USB-Bridge and their interconnections.

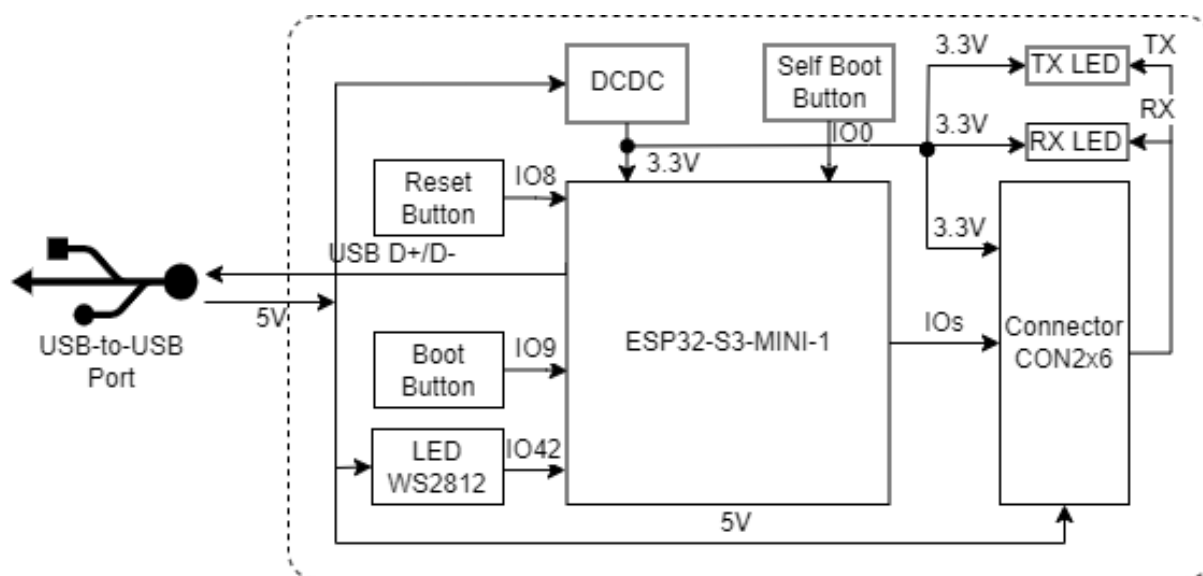

Fig. 7: ESP32-S3-USB-Bridge Block Diagram (Click to Enlarge)

**Description of Components** **ESP32-S3-USB-Bridge** is a rather compact development board, with a dimension of 23.3 mm \* 31.5 mm. It integrates the ESP32-S3-MINI-1 module and offers a 12-pin expansion connector.

The key components of the board are described in a clockwise direction.

Key Component	Description
ESP32-S3-MINI-1-N4R2 Module	ESP32-S3-MINI-1-N4R2 is a generic Wi-Fi + Bluetooth LE MCU module that is built around the ESP32-S3 series of SoCs. It is integrated with 4 MB flash and 2 MB PSRAM. On top of a rich set of peripherals, the acceleration for neural network computing and signal processing workloads provided by the SoC makes the module an ideal choice for a wide variety of application scenarios related to Artificial Intelligence of Things (AIoT).
TX/RX Indicator	Indicates transmit and receive status of serial data.
Expansion Connector	Provides connections for JTAG pins, serial pins, TX/RX pins, Boot pins, Reset pins, and power supply pins.
Reset Button	Connects the Reset button on the target chip and IO8 on the module. Press this button to reset the target chip.
USB-to-USB Port	Provides power to the entire system. Used for USB communication between the PC and the ESP32-S3-MINI-1 module.
Boot Button	Connects the Boot button on the target chip and IO9 on the module. Holding down the Boot button and momentarily pressing the Reset button initiates the firmware upload mode. Then you can upload firmware through the serial port or USB.



Fig. 8: ESP32-S3-USB-Bridge - Front (Click to Enlarge)

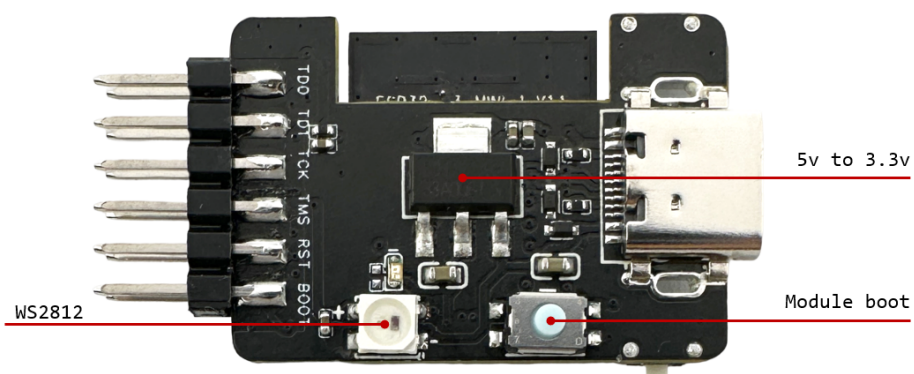

Fig. 9: ESP32-S3-USB-Bridge - Back (Click to Enlarge)

Key Component	Description
5 V to 3.3 V	Converts the USB voltage to 3.3 V for powering the ESP32-S3-MINI-1 module.
Module Boot Button	Connects IO0 on the module. After holding down the Boot button and powering up the development board again, the board enters the download mode and initiates the firmware upload mode for uploading firmware.
WS2812	Connects IO42 on the module and indicates the current state of the development board.

**Software Support** Development of applications for ESP32-S3-USB-Bridge can be done using [ESP-IDF](#) framework. ESP-IDF is a FreeRTOS-based SoC development framework with several components including LCD, ADC, RMT, and SPI. An example is provided for ESP32-S3-LCD-EV-Board under the folder [Examples](#). You can configure project options by entering `idf.py menuconfig` in the example directory.

---

**Note:**

- The current supported ESP-IDF version is release/5.0.
  - To prevent the default firmware from being replaced, please avoid pressing and holding the module's own Boot button while powering the board up/down.
- 

### Start Application Development

This section provides instructions on how to do hardware and software setup and flash firmware onto the board to develop your own application.

#### Required Hardware

- 1 x ESP32-S3-USB-Bridge
  - 1 x LCD subboard
  - 1 x USB 2.0 cable (standard Type-A to Type-C)
  - 1 x PC (Windows, Linux, or macOS)
- 

**Note:** Please make sure to use the appropriate USB cable. Some cables can only be used for charging, not for data transfer or program flashing.

---

**Hardware Setup** Prepare the board for loading of the first sample application:

1. Plug in the USB cable to connect the PC with the USB port on the board.
2. Make sure the board is in the download mode.
3. The LED lights up indicating the completion of flashing.

Now the board is ready for software setup.

**Software Setup** Please proceed to [Get Started](#), where Section [Installation](#) will quickly help you set up the development environment.

For more software information on developing applications, please go to [Software Support](#).

#### Hardware Reference

This section provides more detailed information about the board's hardware.

**GPIO Allocation** The table below provides the GPIO allocation of the ESP32-S3-MINI-1 module and its 12-pin expansion connector, which is used to control specific components or functions on the development board as well as the externally connected target chip.

Table 1: ESP32-S3-MINI-1 and Expansion Connector GPIO Allocation

Pin	Pin Name	Function
1	GND	GND
2	3V3	Power supply
3	IO0	Module boot button for entering download mode which can also be used as a key input pin
4	IO2	JTAG pin TDO for test data output
5	IO3	JTAG pin TDI for test data input
6	IO4	JTAG pin TCK for synchronized test data transfer
7	IO5	JTAG pin TMS for test mode configuration
8	IO8	The Reset pin connecting to the target chip, which sets the target chip to low level when pressed
9	IO9	The Boot pin connecting to the target chip, which sets the target chip to low level when pressed
10	IO19	USB_D-
11	IO20	USB_D+
12	IO40	RX connecting to the UART TX pin of the target chip
13	IO41	TX connecting to the UART RX pin of the target chip
14	IO42	WS2812 control pin

**Note:** Pin 3 to Pin 14 are the corresponding pins of the 12-pin expansion connector. Apart from the features in the above table, all these IO pins support to be configured for other purposes. Note that GPIO5 and GPIO8 should be connected to external keys.

## Power Distribution

**Power Supply over USB** There are two ways to power the development board via the USB power port:

- Via the Type-A port

## TYPE-A

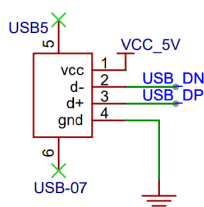

Fig. 10: ESP32-S3-USB-Bridge - Type-A Power Supply

- Via the Type-C port

**Voltage Conversion Circuit** The ESP32-S3-USB-Bridge supports converting 5 V to 3.3 V for the module.

## TYPE-C

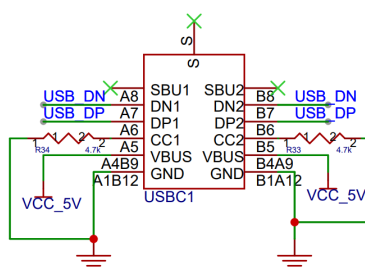

Fig. 11: ESP32-S3-USB-Bridge - Type-C Power Supply

## POWER

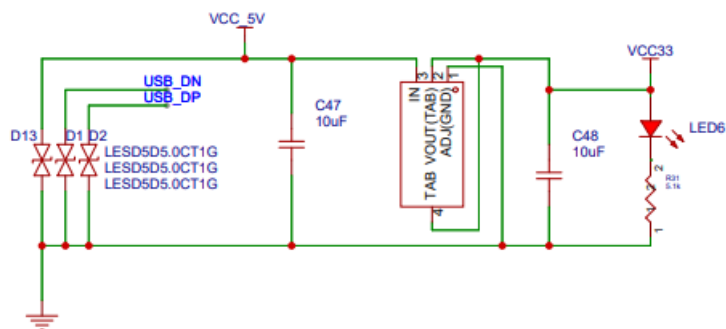

Fig. 12: ESP32-S3-USB-Bridge - Voltage Conversion

### Hardware Setup Options

**Automatic Download** Press the Boot button on the module and re-power up the board, then release the Boot button to allow the board to enter the download mode.

### Hardware Revision Details

No previous revisions.

### Sample Request

This board has been open-sourced to [OSHWHub](#). Please sample it according to your needs.

### Related Documents

Please download the following documents from [the HTML version of esp-dev-kits Documentation](#).

- [ESP32-S3 Datasheet](#)
- [ESP32-S3-MINI-1 Datasheet](#)
- [ESP Product Selector](#)
- [ESP32-S3-USB-Bridge PCB Layout](#)
- [ESP32-S3-USB-Bridge Schematics](#)

For further design documentation for the board, please contact us at [sales@espressif.com](mailto:sales@espressif.com).

ESP32-S3 Development Boards	
	
<p>ESP32-S3-DevKitC-1</p>	<p>ESP32-S3-USB-OTG</p>
	
<p>ESP32-S3-LCD-EV-Board</p>	<p>ESP-VoCat</p>
	
<p>ESP-DualKey</p>	



## Chapter 7

# Related Documentation and Resources

### 7.1 Related Documentation

- [ESP32-S3 Datasheet](#) –Specifications of the ESP32-S3 hardware.
- [ESP32-S3 Technical Reference Manual](#) –Detailed information on how to use the ESP32-S3 memory and peripherals.
- [ESP32-S3 Hardware Design Guidelines](#) –Guidelines on how to integrate the ESP32-S3 into your hardware product.
- ESP32-S3 Product/Process Change Notifications (PCN)  
<https://espressif.com/en/support/documents/pcns?keys=ESP32-S3>
- ESP32-S3 Advisories –Information on security, bugs, compatibility, component reliability.  
<https://espressif.com/en/support/documents/advisories?keys=ESP32-S3>
- Certificates  
<https://espressif.com/en/support/documents/certificates>
- Documentation Updates and Update Notification Subscription  
<https://espressif.com/en/support/download/documents>

### 7.2 Developer Zone

- [ESP-IDF Programming Guide for ESP32-S3](#) –Extensive documentation for the ESP-IDF development framework.
- [ESP-IoT-Solution Programming Guide](#) - Extensive documentation for the ESP-IoT-Solution development framework.
- [ESP-FAQ](#) - A summary document of frequently asked questions released by Espressif.
- ESP-IDF and other development frameworks on GitHub.  
<https://github.com/espressif>
- ESP32 BBS Forum –Engineer-to-Engineer (E2E) Community for Espressif products where you can post questions, share knowledge, explore ideas, and help solve problems with fellow engineers.  
<https://esp32.com/>
- The ESP Journal –Best Practices, Articles, and Notes from Espressif folks.  
<https://blog.espressif.com/>
- See the tabs SDKs and Demos, Apps, Tools, AT Firmware.  
<https://espressif.com/en/support/download/sdks-demos>

## 7.3 Products

- ESP32-S3 Series SoCs –Browse through all ESP32-S3 SoCs.  
<https://espressif.com/en/products/socs?id=ESP32-S3>
- ESP32-S3 Series Modules –Browse through all ESP32-S3-based modules.  
<https://espressif.com/en/products/modules?id=ESP32-S3>
- ESP32-S3 Series DevKits –Browse through all ESP32-S3-based devkits.  
<https://espressif.com/en/products/devkits?id=ESP32-S3>
- ESP Product Selector –Find an Espressif hardware product suitable for your needs by comparing or applying filters.  
<https://products.espressif.com/#/product-selector>

## 7.4 Contact Us

- See the tabs Sales Questions, Technical Enquiries, Circuit Schematic & PCB Design Review, Get Samples (Online stores), Become Our Supplier, Comments & Suggestions.  
<https://espressif.com/en/contact-us/sales-questions>

## Chapter 8

# Disclaimer and Copyright Notice

Information in this document, including URL references, is subject to change without notice.

All third party's information in this document is provided as is with no warranties to its authenticity and accuracy.

No warranty is provided to this document for its merchantability, non-infringement, fitness for any particular purpose, nor does any warranty otherwise arising out of any proposal, specification or sample.

All liability, including liability for infringement of any proprietary rights, relating to use of information in this document is disclaimed. No licenses express or implied, by estoppel or otherwise, to any intellectual property rights are granted herein.

The Wi-Fi Alliance Member logo is a trademark of the Wi-Fi Alliance. The Bluetooth logo is a registered trademark of Bluetooth SIG.

All trade names, trademarks and registered trademarks mentioned in this document are property of their respective owners, and are hereby acknowledged.