

未注公差/General tolerances (mm)											0.1/10 ±2'		
0 ~ 3	>3 ~ 6	>6 ~ 10	>10 ~ 18	>18 ~ 30	>30 ~ 50	>50 ~ 80	>80 ~ 120	>120 ~ 180	>180 ~ 250	>250 ~ 315		>315 ~ 400	>400 ~ 500
±0.12	±0.18	±0.22	±0.26	±0.31	±0.37	±0.57	±0.80	±0.93	±1.05	±1.15	±1.60	±2.20	±2.50

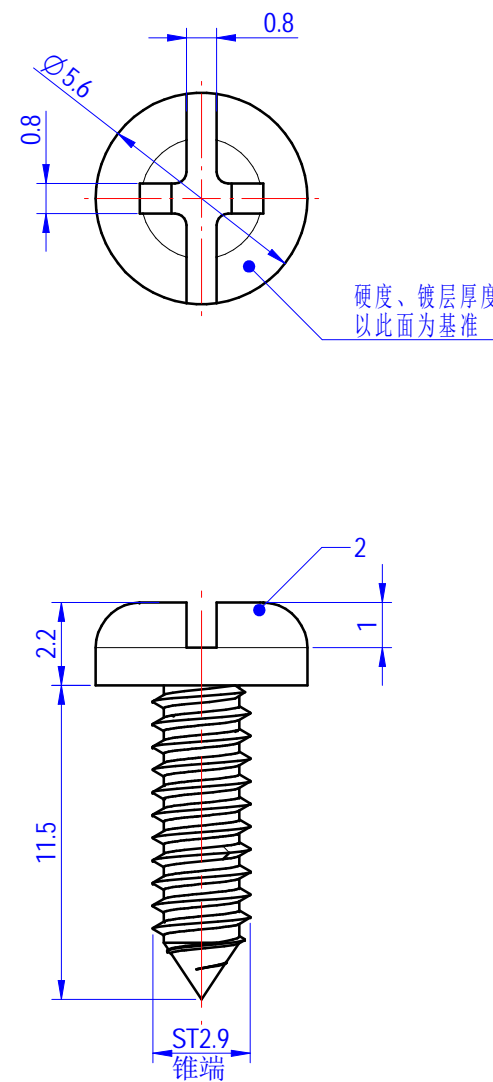
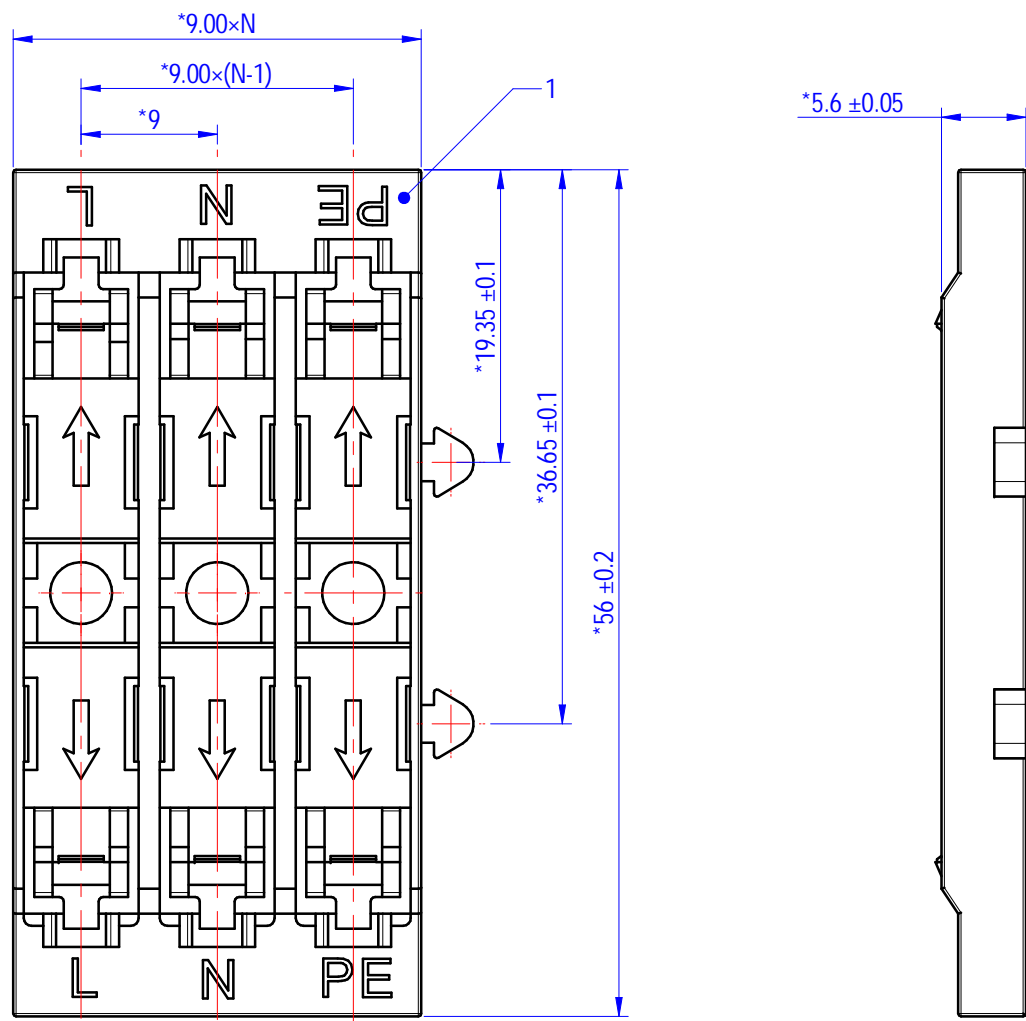

2	Screw	Steel	Ni Plated
1	Housing	PA66	UL94V-0
ITEM	NAME OF PART	MATERIAL	NOTES
间距/Pitch(mm)/线数范围/Poles			9.00/N=02~03P
使用温度范围/Operating temperature(°C)			-40~+105
符合RoHS环保要求/Conform to RoHS			Yes

		MATERIAL: SURFACE/COLOR:	
APPD: 蓝贵凡 2024.07.05		MAT NO./REV: / 00 MAT STATUS: 小批量	
CHKD: 朱伟明 2024.07.05		NAME: DGBSC-ACC03-XXP-1Y-01Z(H)	
DRFT: 孙科豪 2024.07.05		DRAWING NO. TYPE DRAWING STATUS SCALE SHEET	
A3		200315375 CUSTOMER DRAWING 已发布 1:1 1/1	

00	REV	ECN	DESCRIPTION	DRFT	DATE
----	-----	-----	-------------	------	------

Transfer or duplication of this document as well as the utilization or communication of its contents are prohibited unless explicit authorization is granted. Violations will be liable for compensation. All rights reserved for patent. 未经许可，不得复制或传播本文件内容。未经授权，不得利用或传播本文件内容。本公司保留所有权利。侵权必究。