



# RUT204

## CAN BUS LTE ROUTER



Energy &  
utilities



Industrial &  
automation



Smart city



Transportation

### NATIVE CAN BUS

Enable direct access to machine data with CANOpen and J1939 protocol support

### DATA LOGGING

Collect and send data to local or cloud servers for monitoring and analysis

### VERSATILE INTERFACES

Simplify industrial installations with GNSS, RS232, PoE-in, and Ethernet

### REMOTE FLEET MANAGEMENT

Manage connected devices remotely via RMS with zero-touch deployment

## Mobile

Mobile module	4G LTE Cat 4 up to 150 DL/50 UL Mbps; 3G up to 21 DL/5.76 UL Mbps; 2G up to 236.8 DL/236.8 UL kbps
3GPP Release	Release 9
SIM switch	2 SIM cards, auto-switch cases: weak signal, data limit, SMS limit, roaming, no network, network denied, data connection fail, SIM idle protection
Status	IMSI, ICCID, operator, operator state, data connection state, network type, bandwidth, connected band, signal strength (RSSI), SINR, RSRP, RSRQ, EC/IO, RSCP, data sent/received, LAC, TAC, cell ID, ARFCN, UARFCN, EARFCN, MCC, and MNC
SMS	SMS status, SMS configuration, EMAIL to SMS, SMS to EMAIL, SMS to HTTP, SMS to SMS, scheduled SMS, SMS autoreply, SMPP
USSD	Supports sending and reading Unstructured Supplementary Service Data messages
Block/Allow list	Operator block/allow list (by country or separate operators)
Band management	Band lock, Used band status display
SIM idle protection service	Provides the possibility to configure the router to periodically switch to the unused SIM card and establish a data connection in order to prevent the SIM card from being blocked
SIM PIN code management	SIM PIN code management enables setting, changing, or disabling the SIM card's PIN
APN	Auto APN
Bridge	Direct connection (bridge) between mobile ISP and device on LAN
Passthrough	Router assigns its mobile WAN IP address to another device on LAN

## Wireless

Wireless mode	802.11b/g/n (Wi-Fi 4), Access Point (AP), Station (STA)
Wi-Fi security	WPA2-Enterprise: PEAP, WPA2-PSK, WPA-EAP, WPA-PSK, WPA3-SAE, WPA3-EAP, OWE; AES-CCMP, TKIP, Auto-cipher modes, client separation, EAP-TLS with PKCS#12 certificates, disable auto-reconnect, 802.11w Protected Management Frames (PMF)
SSID/ESSID	SSID stealth mode and access control based on MAC address
Wi-Fi users	Up to 50 simultaneous connections
Wireless Connectivity Features	Fast roaming (802.11r), Relayd, BSS transition management (802.11v), radio resource measurement (802.11k)
Wireless MAC filter	Allowlist, blocklist
Wireless QR code generator	Once scanned, a user will automatically enter your network without needing to input login information
TravelMate	Forward Wi-Fi hotspot landing page to a subsequent connected device

## Ethernet

WAN	1 x WAN port 10/100 Mbps, compliance with IEEE 802.3, IEEE 802.3u, 802.3az standards, supports auto MDI/MDIX crossover
LAN	1 x LAN port, 10/100 Mbps, compliance with IEEE 802.3, IEEE 802.3u, 802.3az standards, supports auto MDI/MDIX crossover

## Network

Routing	Static routing, Dynamic routing (BGP, OSPF v2, RIP v1/v2, EIGRP, NHRP), Policy based routing
Network protocols	TCP, UDP, IPv4, IPv6, ICMP, NTP, DNS, HTTP, HTTPS, SFTP, FTP, SMTP, SSL v3, TLS, ARP, VRRP, PPP, PPPoE, UPNP, SSH, DHCP, Telnet, SMPP, SNMP, MQTT, Wake on Lan (WOL), VXLAN
VoIP passthrough support	H.323 and SIP-alg protocol NAT helpers, allowing proper routing of VoIP packets
Connection monitoring	Ping Reboot, Wget Reboot, Periodic Reboot, LCP and ICMP for link inspection
Firewall	Port forward, traffic rules, custom rules, TTL target customisation
Firewall status page	View all your Firewall statistics, rules, and rule counters
Port management	View device ports, enable and disable each of them, turn auto-configuration on or off, change their transmission speed, and so on
Network topology	Visual representation of your network, showing which devices are connected to which other devices
DHCP	Static and dynamic IP allocation, DHCP relay, DHCP server configuration, status, static leases: MAC with wildcards
QoS / Smart Queue Management (SQM)	Traffic priority queuing by source/destination, service, protocol or port, WMM, 802.11e
DDNS	Supported >77 service providers, others can be configured manually
DNS over HTTPS	DNS over HTTPS proxy enables secure DNS resolution by routing DNS queries over HTTPS
Network backup	Wi-Fi WAN, Mobile, VRRP, Wired options, each of which can be used as an automatic Failover
Load balancing	Balance Internet traffic over multiple WAN connections
Hotspot	Captive portal (hotspot), internal/external Radius server, Radius MAC authentication, SMS authorisation, SSO authentication, internal/external landing page, walled garden, user scripts, URL parameters, user groups, individual user or group limitations, user management, 9 default customisable themes and optionality to upload and download customised hotspot themes
Hotspot 2.0	Hotspot 2.0 is a Wi-Fi standard that enables seamless, secure, and automatic connection to trusted wireless networks
SSHFS	Possibility to mount remote file system via SSH protocol
Traffic Management	Real-time monitoring, wireless signal charts, traffic usage history

## Security

Authentication	Pre-shared key, digital certificates, X.509 certificates, TACACS+, Internal & External RADIUS users authentication, IP & login attempts block, time-based login blocking, built-in random password generator
Firewall	Preconfigured firewall rules can be enabled via WebUI, unlimited firewall configuration via CLI, DMZ, NAT, NAT-T, NAT64
Attack prevention	DDOS prevention (SYN flood protection, SSH attack prevention, HTTP/HTTPS attack prevention), port scan prevention (SYN-FIN, SYN-RST, X-mas, NULL flags, FIN scan attacks)
VLAN	Port and tag-based VLAN separation
Mobile quota control	Mobile data limit, customizable period, start time, warning limit, phone number
WEB filter	Block list for blocking out unwanted websites, allow list for specifying allowed sites only
Access control	Flexible access control of SSH, Web interface, CLI and Telnet
Certificate Manager	Certificate creation tool allows to create CA, server, client, let's encrypt, SCEP certificates
802.1x	Port-based network access control server

## VPN

OpenVPN	Multiple clients and a server can run simultaneously, 27 encryption methods
OpenVPN Encryption	DES-CBC 64, RC2-CBC 128, DES-EDE-CBC 128, DES-EDE3-CBC 192, DESX-CBC 192, BF-CBC 128, RC2-40-CBC 40, CAST5-CBC 128, RC2-64-CBC 64, AES-128-CBC 128, AES-128-CFB 128, AES-128-CFB1 128, AES-128-CFB8 128, AES-128-OFB 128, AES-128-GCM 128, AES-192-CFB 192, AES-192-CFB1 192, AES-192-CFB8 192, AES-192-OFB 192, AES-192-CBC 192, AES-192-GCM 192, AES-256-GCM 256, AES-256-CFB 256, AES-256-CFB1 256, AES-256-CFB8 256, AES-256-OFB 256, AES-256-CBC 256
IPsec	XFRM, IKEv1, IKEv2, with 14 encryption methods for IPsec (3DES, DES, AES128, AES192, AES256, AES128GCM8, AES192GCM8, AES256GCM8, AES128GCM12, AES192GCM12, AES256GCM12, AES128GCM16, AES192GCM16, AES256GCM16)
GRE	GRE tunnel, GRE tunnel over IPsec support
PPTP, L2TP	Client/Server instances can run simultaneously, L2TPv3, L2TP over IPsec support
Stunnel	Proxy designed to add TLS encryption functionality to existing clients and servers without any changes in the program's code
DMVPN	Method of building scalable IPsec VPNs, Phase 2 and Phase 3 and Dual Hub support
SSTP	SSTP client instance support
ZeroTier	ZeroTier VPN client support
WireGuard	WireGuard VPN client and server support
Tinc	Tinc offers encryption, authentication and compression in it's tunnels. Client and server support.
EoIP	Ethernet over IP (EoIP) Tunneling is a MikroTik RouterOS protocol based on GRE RFC 1701 that creates an Ethernet tunnel between two routers on top of an IP connection
OpenConnect	Cross-platform multi-protocol SSL VPN client which supports a number of VPN protocols

### BacNET

---

Supported modes	Router
-----------------	--------

---

Supported connection types	RTU(RS232)
----------------------------	------------

---

Configuration options	Support for multiple BACnet/IP interfaces, Network number assignment, Preconfigured BDT entries for BBMD (BACnet Broadcast Management Device)
-----------------------	---

### OPC UA

---

Supported modes	Client, Server
-----------------	----------------

---

Supported connection types	TCP
----------------------------	-----

### MODBUS

---

Supported modes	Server, Client
-----------------	----------------

---

Supported connection types	RTU(RS232)
----------------------------	------------

---

Custom registers	MODBUS TCP custom register block requests, which read/write to a file inside the router, and can be used to extend MODBUS TCP Client functionality
------------------	--

---

Supported data formats	8-bit: INT, UINT; 16-bit: INT, UINT (MSB or LSB first); 32-bit: float, INT, UINT (ABCD (big-endian), DCBA (little-endian), CDAB, BADC), HEX, ASCII
------------------------	--

### Data to Server

---

Protocol	HTTP(S), MQTT, Azure MQTT
----------	---------------------------

---

Data to server	Extract parameters from multiple sources and different protocols, and send them all to a single server; Custom LUA scripting, allowing scripts to utilize the router's Data to server feature
----------------	---

### MQTT Gateway

---

Modbus MQTT Gateway	Allows sending commands and receiving data from MODBUS Server through MQTT broker
---------------------	---

### DNP3

---

Supported modes	TCP Master, DNP3 Outstation
-----------------	-----------------------------

---

Supported connection types	RTU(RS232)
----------------------------	------------

### DLMS/COSEM

---

DLMS Support	DLMS - standard protocol for utility meter data exchange
--------------	--

---

Supported modes	Client
-----------------	--------

---

Supported connection types	TCP, RTU(RS232)
----------------------------	-----------------

## CAN

CAN Gateway	Allows forwarding CAN frames over IP networks.
-------------	--

## API

Teltonika Networks Web API (beta) support	Expand your device's possibilities by using a set of configurable API endpoints to retrieve or change data. For more information, please refer to this documentation: <a href="https://developers.teltonika-networks.com">https://developers.teltonika-networks.com</a>
--	--

## Monitoring & Management

WEB UI	HTTP/HTTPS, status, configuration, FW update, CLI, troubleshoot, multiple event log servers, firmware update availability notifications, event log, system log, kernel log, Internet status
FOTA	Firmware update from server, automatic notification
SSH	SSH (v1, v2)
SMS	SMS status, SMS configuration
Call	Reboot, Status, Mobile data on/off, Output on/off, answer/hang-up with a timer, Wi-Fi on/off
TR-069	OpenACS, EasyCwmp, ACSLite, tGem, LibreACS, GenieACS, FreeACS, LibCWMP, Friendly tech, AVSystem
MQTT	MQTT Broker, MQTT publisher
SNMP	SNMP (v1, v2, v3), SNMP Trap, Brute force protection
JSON-RPC	Management API over HTTP/HTTPS
RMS	Teltonika Remote Management System (RMS)

## IoT Platforms

ThingWorx	Allows monitoring of: WAN Type, WAN IP, Mobile Operator Name, Mobile Signal Strength, Mobile Network Type
Cumulocity - Cloud of Things	Allows monitoring of: Device Model, Revision and Serial Number, WAN Type and IP, Mobile Cell ID, ICCID, IMEI, Connection Type, Operator, Signal Strength. Has reboot and firmware upgrade actions
Azure IoT Hub	Can be configured with Data to Server to send all the available parameters to the cloud. Has Direct method support which allows to execute RutOS API calls on the IoT Hub. Also has Plug and Play integration with Device Provisioning Service that allows zero-touch device provisioning to IoT Hubs
AWS IoT Core	Utility to interact with the AWS cloud platform. Jobs Support: Call the device's API using AWS Jobs functionality

## System Characteristics

CPU	Mediatek, 580 MHz, MIPS 24KEc
RAM	128 MB, DDR2
FLASH storage	32 MB, NOR Flash

### Firmware/Configuration

WEB UI	Update FW from file, check FW on server, configuration profiles, configuration backup
FOTA	Update FW
RMS	Update FW/configuration for multiple devices at once
Keep settings	Update FW without losing current configuration
Factory settings reset	A full factory reset restores all system settings, including the IP address, PIN, and user data to the default manufacturer's configuration

### FIRMWARE CUSTOMISATION

Operating system	RutOS (OpenWrt based Linux OS)
Supported languages	Busybox shell, Lua, C, C++
Development tools	SDK package with build environment provided
GPL customization	You can create your own custom, branded firmware and web page application by changing colours, logos, and other elements in our firmware to fit your or your clients' needs
Package Manager	The Package Manager is a service used to install additional software on the device

### Location Tracking

GNSS	GPS, GLONASS, BeiDou, Galileo and QZSS
Coordinates	GNSS coordinates via WebUI, SMS, TAVL, RMS
NMEA	NMEA 0183
NTRIP	NTRIP protocol (Networked Transport of RTCM via Internet Protocol)
Server software	Supported server software TAVL, RMS
Geofencing	Configurable multiple geofence zones

### Serial

RS232	RS232 only TX and RX signals
CAN	Integrated CAN interface
Serial functions	Console, Serial over IP, Modem, MODBUS gateway, NTRIP Client

### Input/Output

Events	Email, RMS, SMS
--------	-----------------

### SD CARD

Physical size	Micro SD (internal)
Applications	Samba share
Capacity	Up to 2 TB
Storage formats	FAT32, NTFS, ext2, ext3, ext4

**POE IN**

PoE ports	1 x PoE In
PoE standards	Active PoE input 802.3af Class 0 (12.94 W) on LAN port

**Power**

Connector	2-pin industrial DC power socket
Input voltage range	9 - 57 VDC, reverse polarity protection 100 V max, surge protection min 64.4 V/max 71.2 V breakdown voltage, 93.6 V max reverse voltage @ 4.3 A max reverse surge current
PoE (passive)	Passive PoE over spare pairs 4,5 (+) / 7,8 (-). Possibility to power up through LAN port, passive PoE voltage: 16 - 57 VDC
Power consumption	Idle: < 2 W, Max: < 3.5 W

**Physical Interfaces**

Ethernet	2 x RJ45 ports, 10/100 Mbps
Status LEDs	1 x Connection type status RGB LED, 1 x Connection strength RGB LED, 2 x ETH status LEDs, 1 x Power LED
SIM	2 x internal SIM slots (Mini SIM – 2FF), 1.8 V/3 V, double stacked SIM tray
Power	1 x 2-pin power connector
Antennas	2 x SMA for Mobile, 1 x RP-SMA for Wi-Fi, 1 x SMA for GNSS
RS232, CAN	1 x 6-pin terminal block
Reset	Reboot/User default reset/Factory reset button

**Physical Specification**

Casing material	Anodized aluminum housing and panels
Dimensions (W x H x D)	83 x 25 x 83 mm
Weight	140 g
Mounting options	DIN rail, wall mount, flat surface (all require additional kit)

**Operating Environment**

Operating temperature	-40 °C to 75 °C
Operating humidity	10% to 90% non-condensing
Ingress Protection Rating	IP30

**Regulatory & Type Approvals**

Regulatory	CE, UKCA, CB, RCM, EAC, UCRF
------------	------------------------------

## Hardware

### FRONT VIEW

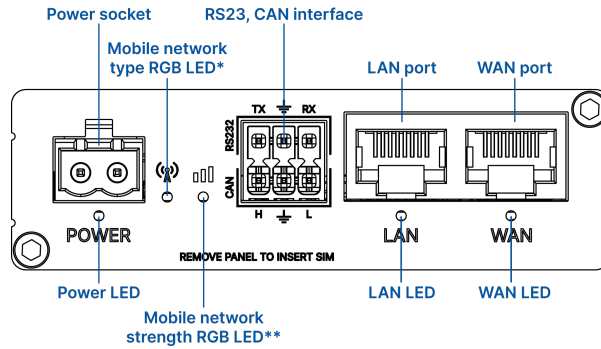

<b>Mobile network type RGB LED*</b>	RED - 2G connection YELLOW - 3G Connection GREEN - 4G connection
<b>Mobile signal strength RGB LED**</b>	None ≤ -111 dBm RED -110 dBm to -82 dBm GREEN -81 dBm to -52 dBm BLUE ≥ -51 dBm

### BACK VIEW

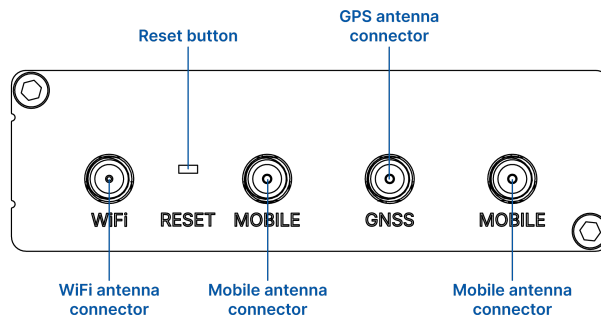

### 6-PIN TERMINAL BLOCK

1. RS232 driver signal (TX)
2. Device ground (GND)
3. RS232 receiver signal (RX)
4. Low-level (H)
5. Device ground (GND)
6. High-level (L)

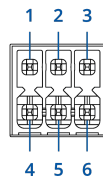

### POWER SOCKET PINOUT

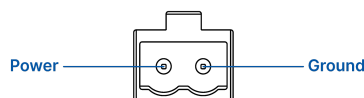

## Ordering

Standard package\*



RUT204



QUICK START GUIDE

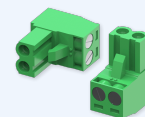

2-PIN TERMINAL BLOCK

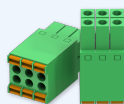

2X3PIN CONNECTOR



HEX KEY



ETHERNET CABLE 1.5 M



SIM ADAPTER KIT

\*Standard package contents may differ based on standard order codes.

For more information on all available packaging options – please [contact us](#) directly.

## Classification codes

**HS Code:** 851762

**HTS:** 8517.62.00

For more information on all available packaging options – please [contact us](#) directly.

## Available versions

Hardware version	Supported frequencies	Standard order code / Package Contains
RUT204 *A**** Europe <sup>1</sup> , Australia, Asia-Pacific	<b>4G (LTE-FDD):</b> B1, B3, B5, B7, B8, B20, B28 <b>4G (LTE-TDD):</b> B38, B40, B41 <b>3G:</b> B1, B5, B8 <b>2G:</b> B3, B8	RUT2040AAAA0 / Standard package without PSU RUT2040AAAD0 / Mass packing code

The price and lead-times for region (operator) specific versions may vary. For more information please [contact us](#).

1 - Regional availability - excluding Russia, Belarus & Iran

## RUT204 spatial measurements

### Available versions

Device housing (W x H x D)	83 x 25 x 83 mm
Box:	100 x 32 x 108 mm

**TOP VIEW**

The figure below depicts the measurements of device and its components as seen from the top:

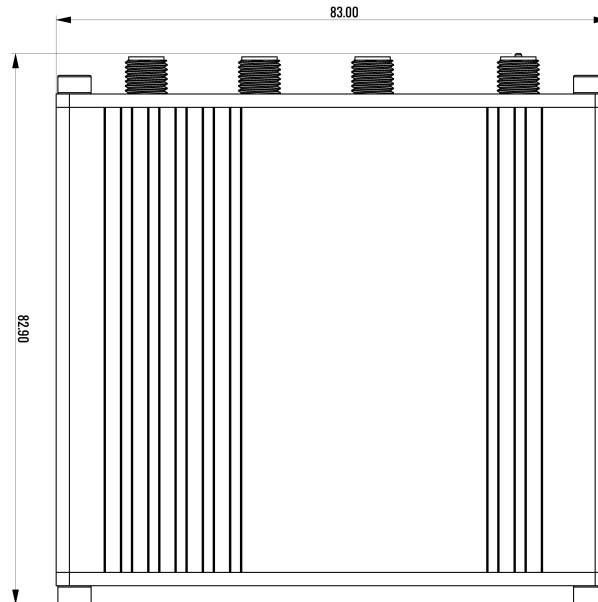

**RIGHT VIEW**

The figure below depicts the measurements of device and its components as seen from the right:

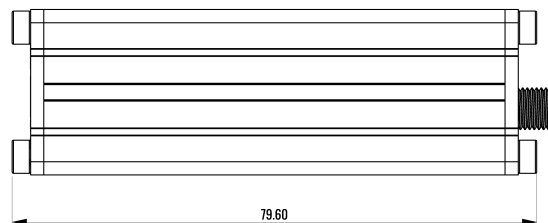

**FRONT VIEW**

The figure below depicts the measurements of device and its components as seen from the front panel side:

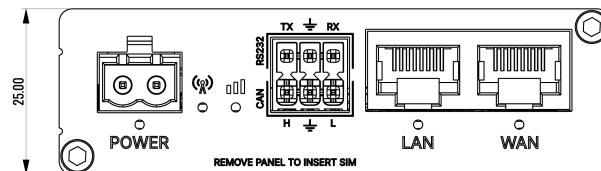

### REAR VIEW

The figure below depicts the measurements of device and its components as seen from the back panel side:

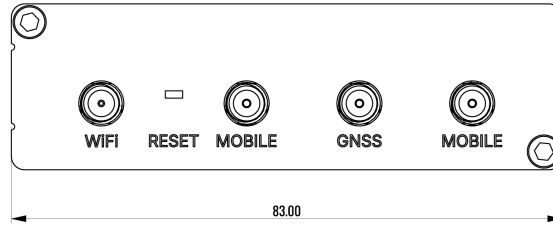

### MOUNTING SPACE REQUIREMENTS

The figure below depicts an approximation of the device's dimensions when cables and antennas are attached:

