

G521B-2\$;G521G-2\$

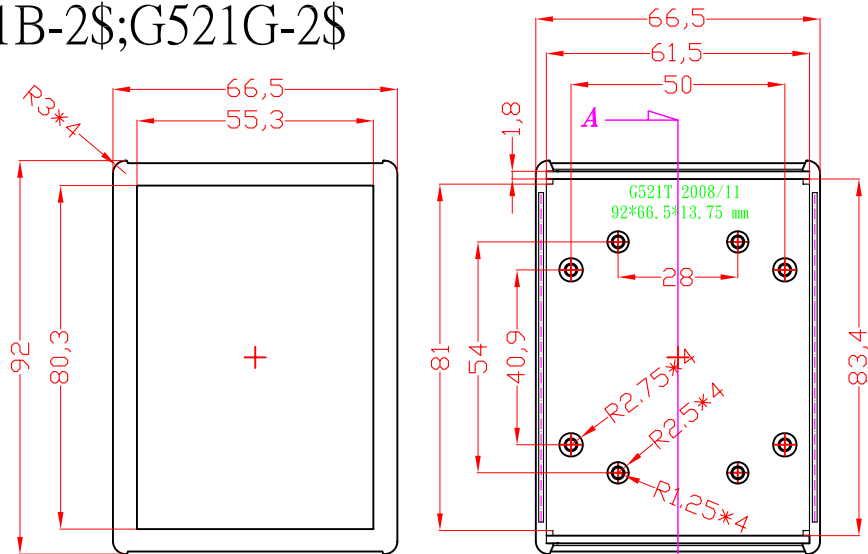

TOP

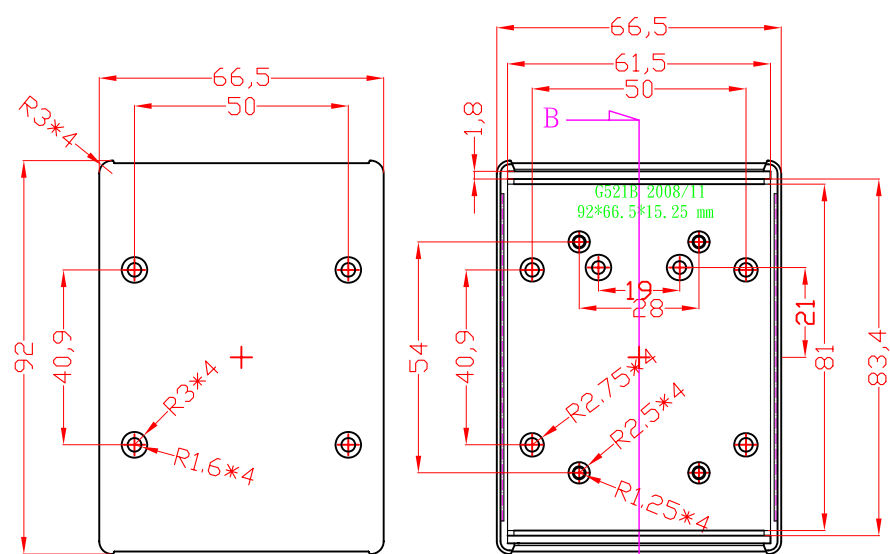

BASE

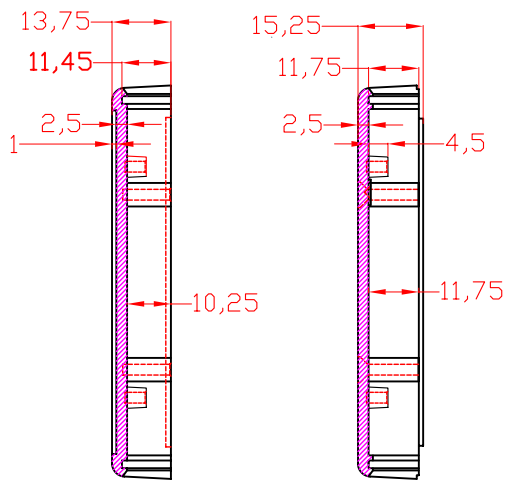
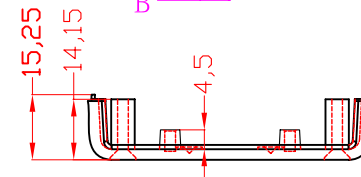
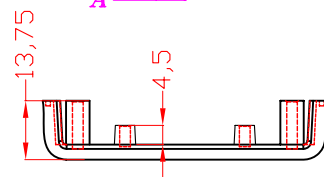

A-A

B-B

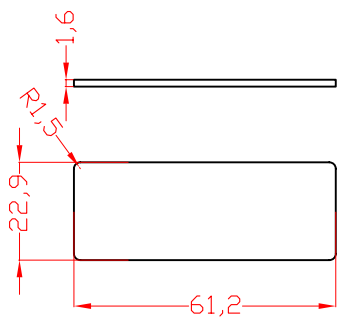

PANEL-"\$"

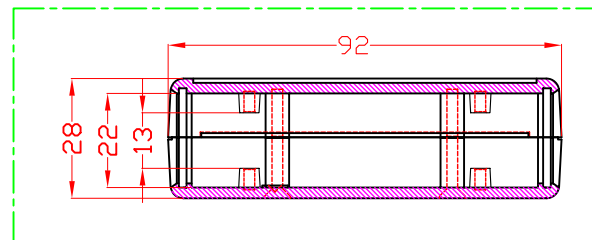

According to ISO 2768-m	
Measuring DIM=L	Tolerance
0.5<L≤3.0 mm	±0.1 mm
3.0<L≤6.0 mm	±0.1 mm
6.0<L≤30.0 mm	±0.2 mm
30.0<L≤120.0 mm	±0.3 mm
120.0<L≤400.0 mm	±0.5 mm
400.0<L≤1000.0 mm	±0.8 mm

ITEM NO	DESCRIPTION
G521B-2\$	BLACK(G521T+G521B)*1+BLACK(PANEL-"\$")*2+M3*21 mm BLACK SCREWS *4
G521G-2\$	GRAY(G521T+G521B)*1+GRAY(PANEL-"\$")*2+M3*21 mm BLACK SCREWS *4

宜又實業有限公司
GAINTA INDUSTRIES LTD.

設計 DES'D BY
BY

繪圖 DRA'D BY
BY JACKY

核圖 CHK'D BY
BY

比例 SCALE

日期 DATE
2009/1/7

材質 MATE.
ABS

圖名 TITLE:
G521B-2\$;G521G-2\$

圖號 DWG NO.:

圖號 REVISID
A
說明 DESCRIPTION