



# **PIC18F4XK20 Starter Kit User's Guide**

---

---

**Note the following details of the code protection feature on Microchip devices:**

- Microchip products meet the specification contained in their particular Microchip Data Sheet.
- Microchip believes that its family of products is one of the most secure families of its kind on the market today, when used in the intended manner and under normal conditions.
- There are dishonest and possibly illegal methods used to breach the code protection feature. All of these methods, to our knowledge, require using the Microchip products in a manner outside the operating specifications contained in Microchip's Data Sheets. Most likely, the person doing so is engaged in theft of intellectual property.
- Microchip is willing to work with the customer who is concerned about the integrity of their code.
- Neither Microchip nor any other semiconductor manufacturer can guarantee the security of their code. Code protection does not mean that we are guaranteeing the product as "unbreakable."

Code protection is constantly evolving. We at Microchip are committed to continuously improving the code protection features of our products. Attempts to break Microchip's code protection feature may be a violation of the Digital Millennium Copyright Act. If such acts allow unauthorized access to your software or other copyrighted work, you may have a right to sue for relief under that Act.

---

Information contained in this publication regarding device applications and the like is provided only for your convenience and may be superseded by updates. It is your responsibility to ensure that your application meets with your specifications. MICROCHIP MAKES NO REPRESENTATIONS OR WARRANTIES OF ANY KIND WHETHER EXPRESS OR IMPLIED, WRITTEN OR ORAL, STATUTORY OR OTHERWISE, RELATED TO THE INFORMATION, INCLUDING BUT NOT LIMITED TO ITS CONDITION, QUALITY, PERFORMANCE, MERCHANTABILITY OR FITNESS FOR PURPOSE. Microchip disclaims all liability arising from this information and its use. Use of Microchip devices in life support and/or safety applications is entirely at the buyer's risk, and the buyer agrees to defend, indemnify and hold harmless Microchip from any and all damages, claims, suits, or expenses resulting from such use. No licenses are conveyed, implicitly or otherwise, under any Microchip intellectual property rights.

**Trademarks**

The Microchip name and logo, the Microchip logo, Accuron, dsPIC, KEELOQ, KEELOQ logo, MPLAB, PIC, PICmicro, PICSTART, PRO MATE, rPIC and SmartShunt are registered trademarks of Microchip Technology Incorporated in the U.S.A. and other countries.

FilterLab, Linear Active Thermistor, MXDEV, MXLAB, SEEVAL, SmartSensor and The Embedded Control Solutions Company are registered trademarks of Microchip Technology Incorporated in the U.S.A.

Analog-for-the-Digital Age, Application Maestro, CodeGuard, dsPICDEM, dsPICDEM.net, dsPICworks, dsSPEAK, ECAN, ECONOMONITOR, FanSense, In-Circuit Serial Programming, ICSP, ICEPIC, Mindi, MiWi, MPASM, MPLAB Certified logo, MPLIB, MPLINK, mTouch, PICkit, PICDEM, PICDEM.net, PICtail, PIC<sup>32</sup> logo, PowerCal, PowerInfo, PowerMate, PowerTool, REAL ICE, rLAB, Select Mode, Total Endurance, UNI/O, WiperLock and ZENA are trademarks of Microchip Technology Incorporated in the U.S.A. and other countries.

SQTP is a service mark of Microchip Technology Incorporated in the U.S.A.

All other trademarks mentioned herein are property of their respective companies.

© 2008, Microchip Technology Incorporated, Printed in the U.S.A., All Rights Reserved.

 Printed on recycled paper.

**QUALITY MANAGEMENT SYSTEM**  
**CERTIFIED BY DNV**  
**== ISO/TS 16949:2002 ==**

*Microchip received ISO/TS-16949:2002 certification for its worldwide headquarters, design and wafer fabrication facilities in Chandler and Tempe, Arizona; Gresham, Oregon and design centers in California and India. The Company's quality system processes and procedures are for its PIC<sup>®</sup> MCUs and dsPIC<sup>®</sup> DSCs, KEELOQ<sup>®</sup> code hopping devices, Serial EEPROMs, microperipherals, nonvolatile memory and analog products. In addition, Microchip's quality system for the design and manufacture of development systems is ISO 9001:2000 certified.*

**Table of Contents**

**Preface** ..... 1

**Chapter 1. PIC18F4XK20 Starter Kit Overview**

    1.1 Overview ..... 5

    1.2 Highlights ..... 5

    1.3 PIC18F4XK20 Starter Kit Contents ..... 5

    1.4 PIC18F4XK20 Starter Kit Layout ..... 6

        1.4.1 Analog Input Filtering Circuit ..... 7

        1.4.2 PWM Filtering from RC2 ..... 7

        1.4.3 PICtail™ Daughter Board Interface ..... 7

        1.4.4 PICKit™ Serial Analyzer Connector ..... 7

        1.4.5 ICSP™ (In-Circuit Serial Programmer™) Connector ..... 7

        1.4.6 Temperature Sensor ..... 8

        1.4.7 25LC1024 Serial EEPROM ..... 8

        1.4.8 32.768 kHz Crystal ..... 8

        1.4.9 128x64 OLED ..... 8

    1.5 Powering the Demo Board ..... 8

    1.6 Quick Start Guide ..... 8

        1.6.1 Downloading Demonstration Software ..... 8

    1.7 Programming Lessons ..... 10

**Chapter 2. Troubleshooting**

    2.1 Introduction ..... 11

        2.1.1 The board does not power up. .... 11

        2.1.2 Microcontroller is not executing code. .... 11

        2.1.3 The microcontroller will not program. .... 11

**Appendix A. Board Schematics**

    A.1 Introduction ..... 13

**Worldwide Sales and Service** ..... 20

# PIC18F4XK20 Starter Kit User's Guide

---

NOTES:

---

---

## Preface

---

---

### NOTICE TO CUSTOMERS

All documentation becomes dated, and this manual is no exception. Microchip tools and documentation are constantly evolving to meet customer needs, so some actual dialogs and/or tool descriptions may differ from those in this document. Please refer to our web site ([www.microchip.com](http://www.microchip.com)) to obtain the latest documentation available.

Documents are identified with a “DS” number. This number is located on the bottom of each page, in front of the page number. The numbering convention for the DS number is “DSXXXXA”, where “XXXX” is the document number and “A” is the revision level of the document.

For the most up-to-date information on development tools, see the MPLAB® IDE on-line help. Select the Help menu, and then Topics to open a list of available on-line help files.

## INTRODUCTION

This chapter contains general information that will be useful to know before using the PIC18F4XK20 Starter Kit. Items discussed in this chapter include:

- Document Layout
- Conventions Used in this Guide
- Recommended Reading
- The Microchip Web Site
- Development Systems Customer Change Notification Service
- Customer Support
- Document Revision History

## DOCUMENT LAYOUT

This document describes how to use the PIC18F4XK20 Starter Kit as a development tool to emulate and debug firmware on a target board. The manual layout is as follows:

- **Chapter 1. PIC18F4XK20 Starter Kit Overview** – Introduces the PIC18F4XK20 Starter Kit and provides a brief description of the hardware and the new features.
- **Chapter 2. Troubleshooting** – Describes the common problems of the PIC18F4XK20 Demonstration Board and their solutions.
- **Appendix A. Board Schematics** – Provides schematic diagrams for the PIC18F4XK20 Demonstration Board.

# PIC18F4XK20 Starter Kit User's Guide

## CONVENTIONS USED IN THIS GUIDE

This manual uses the following documentation conventions:

### DOCUMENTATION CONVENTIONS

Description	Represents	Examples
<b>Arial font:</b>		
Italic characters	Referenced books	<i>MPLAB® IDE User's Guide</i>
	Emphasized text	...is the <i>only</i> compiler...
Initial caps	A window	the Output window
	A dialog	the Settings dialog
	A menu selection	select Enable Programmer
Quotes	A field name in a window or dialog	"Save project before build"
Underlined, italic text with right angle bracket	A menu path	<u><i>File&gt;Save</i></u>
Bold characters	A dialog button	Click <b>OK</b>
	A tab	Click the <b>Power</b> tab
N'Rnnnn	A number in verilog format, where N is the total number of digits, R is the radix and n is a digit.	4'b0010, 2'hF1
Text in angle brackets < >	A key on the keyboard	Press <Enter>, <F1>
<b>Courier New font:</b>		
Plain Courier New	Sample source code	#define START
	Filenames	autoexec.bat
	File paths	c:\mcc18\h
	Keywords	_asm, _endasm, static
	Command-line options	-Opa+, -Opa-
	Bit values	0, 1
	Constants	0xFF, 'A'
Italic Courier New	A variable argument	<i>file.o</i> , where <i>file</i> can be any valid filename
Square brackets [ ]	Optional arguments	mcc18 [options] <i>file</i> [options]
Curly brackets and pipe character: {   }	Choice of mutually exclusive arguments; an OR selection	errorlevel {0 1}
Ellipses...	Replaces repeated text	var_name [, var_name...]
	Represents code supplied by user	void main (void) { ... }

## RECOMMENDED READING

This user's guide describes how to use the PIC18F4XK20 Starter Kit. Other useful documents are listed below. The following Microchip documents are available and recommended as supplemental reference resources.

### **PIC18F46K20 Data Sheet (DS41303)**

This data sheet summarizes the features of the PIC18F46K20. It provides essential information needed to develop software for this device.

### **MCP9700/9700A and MCP9701/9701A Data Sheet (DS21942)**

This data sheet summarizes the features of the MCP9700/9700A and MCP9701/9701A. It provides essential information needed to develop software for these devices.

### **MCP001/2/4 Data Sheet (DS21733)**

This data sheet summarizes the features of the MCP001/2/4. It provides essential information needed to develop software for these devices.

### **25LC1024 Data Sheet (DS22064)**

This data sheet summarizes the features of the 25LC1024. It provides essential information needed to develop software for this device.

## THE MICROCHIP WEB SITE

Microchip provides online support via our web site at [www.microchip.com](http://www.microchip.com). This web site is used as a means to make files and information easily available to customers. Accessible by using your favorite Internet browser, the web site contains the following information:

- **Product Support** – Data sheets and errata, application notes and sample programs, design resources, user's guides and hardware support documents, latest software releases and archived software
- **General Technical Support** – Frequently Asked Questions (FAQs), technical support requests, online discussion groups, Microchip consultant program member listing
- **Business of Microchip** – Product selector and ordering guides, latest Microchip press releases, listing of seminars and events, listings of Microchip sales offices, distributors and factory representatives

# PIC18F4XK20 Starter Kit User's Guide

---

## DEVELOPMENT SYSTEMS CUSTOMER CHANGE NOTIFICATION SERVICE

Microchip's customer notification service helps keep customers current on Microchip products. Subscribers will receive e-mail notification whenever there are changes, updates, revisions or errata related to a specified product family or development tool of interest.

To register, access the Microchip web site at [www.microchip.com](http://www.microchip.com), click on Customer Change Notification and follow the registration instructions.

The Development Systems product group categories are:

- **Compilers** – The latest information on Microchip C compilers and other language tools. These include the MPLAB C18 and MPLAB C30 C compilers; MPASM™ and MPLAB ASM30 assemblers; MPLINK™ and MPLAB LINK30 object linkers; and MPLIB™ and MPLAB LIB30 object librarians.
- **Emulators** – The latest information on Microchip in-circuit emulators. This includes the MPLAB ICE 2000 and MPLAB ICE 4000.
- **In-Circuit Debuggers** – The latest information on the Microchip in-circuit debugger, MPLAB ICD 2.
- **MPLAB® IDE** – The latest information on Microchip MPLAB IDE, the Windows® Integrated Development Environment for development systems tools. This list is focused on the MPLAB IDE, MPLAB SIM simulator, MPLAB IDE Project Manager and general editing and debugging features.
- **Programmers** – The latest information on Microchip programmers. These include the MPLAB PM3 and PRO MATE® II device programmers and the PICSTART® Plus and PICKit™ 1 development programmers.

## CUSTOMER SUPPORT

Users of Microchip products can receive assistance through several channels:

- Distributor or Representative
- Local Sales Office
- Field Application Engineer (FAE)
- Technical Support

Customers should contact their distributor, representative or field application engineer (FAE) for support. Local sales offices are also available to help customers. A listing of sales offices and locations is included in the back of this document.

Technical support is available through the web site at: <http://support.microchip.com>

## DOCUMENT REVISION HISTORY

### Revision A (March 2008)

- Initial Release of this Document.

### Revision B (April 2008)

- Removed reference to OLED Data Sheet



---

---

## Chapter 1. PIC18F4XK20 Starter Kit Overview

---

---

The PIC18F4XK20 Starter Kit is a demonstration and development tool designed for those getting started with microcontrollers or those looking to migrate to the new PIC18F4XK20/2XK20 family. The board is designed for general purpose applications and includes a variety of hardware to exercise microcontroller peripherals.

### 1.1 OVERVIEW

The PIC18F4XK20/2XK20 is a new family of microcontrollers that take advantage of Microchip's latest process technology. Among the most notable of the new features are:

- lower power consumption
- high-performance operation and
- low-cost

Several firmware demos that showcase some of the features are included, as well as a PICkit™ 2 Development Programmer, which can be used to download the demos onto the development board.

The hardware included on the board allows for development as well. The microcontroller that is populated on the board, the PIC18F46K20, is the superset of the PIC18F4XK20/2XK20 family. Included on the board are various analog and digital circuitry used in microcontroller applications, in addition to a header which breaks out all signal lines for analysis or interfacing to external devices.

### 1.2 HIGHLIGHTS

This chapter discusses the features of the PIC18F4XK20 Starter Kit. Topics discussed include:

- PIC18F4XK20 Starter Kit Contents
- PIC18F4XK20 System Management Layout
- Powering the Demo Board
- Quick Start Guide
- Programming Lessons

### 1.3 PIC18F4XK20 STARTER KIT CONTENTS

The PIC18F4XK20 Starter Kit includes the following items:

- PIC18F4XK20 Starter Kit Board
- PIC18F4XK20 CD-ROM, which includes:
  - PIC18F4XK20 Starter Kit User's Guide
  - PIC18F4XK20 Schematics and Layout
  - Labs and Demo Software Source Code
  - PIC18F4XK20/2XK20 Data Sheets
  - 25LC1024 Data Sheet
- PICkit 2 Development Programmer
- Programming Lessons

# PIC18F4XK20 Starter Kit User's Guide

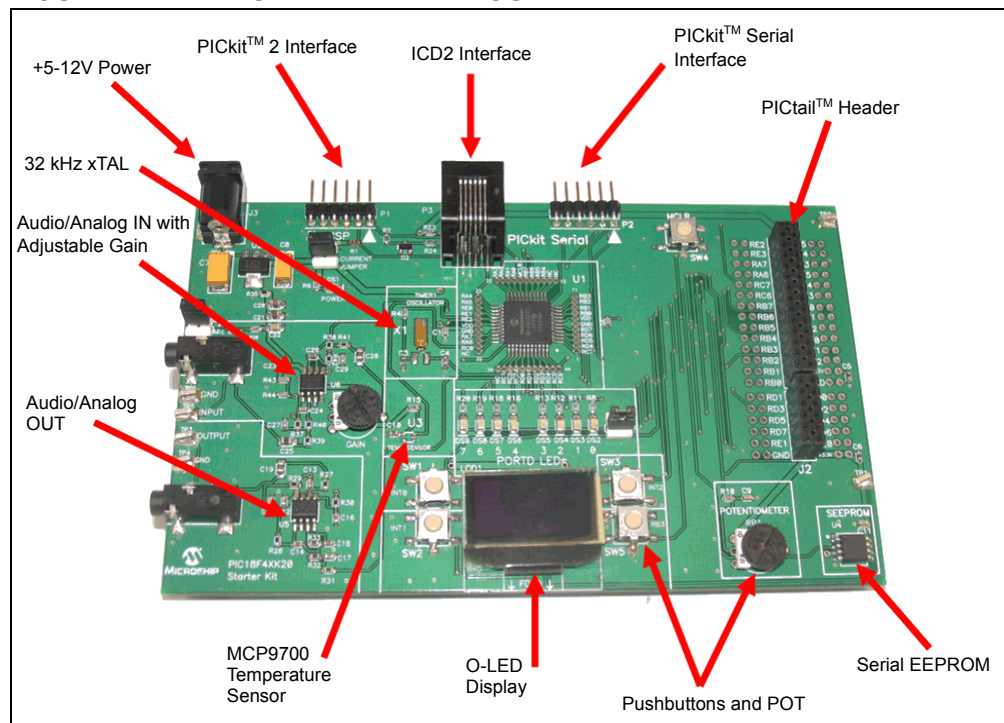
If you are missing any part of the kit, please contact your nearest Microchip sales office listed on the back of this publication.

## 1.4 PIC18F4XK20 STARTER KIT LAYOUT

The PIC18F4XK20 Starter Kit Board is populated with a PIC18F46K20 microcontroller. In addition, the board is also populated with the following features/components:

- 128x64 Organic LED Display (SPI)
- 32.768 kHz External Oscillator (Timer1)
- Analog Input Filtering and Gain Control into RE1 (1.4.1)
- PWM Output Filtering from RC2 (1.4.2)
- 4 Push Buttons for User Interfacing
- 1 MCLR switch
- 8 LEDs mapped to PORTD
- Potentiometer
- 1024 KB Serial EEPROM
- PICtail™ daughter board header (breaks out all pins)
- 6-Pin ICSP™ programming capability header
- 6-Pin PICkit serial analyzer interface
- Current measurement jumper
- RJ-11 ICSP programming header

**FIGURE 1-1: STARTER KIT LAYOUT**



## 1.4.1 Analog Input Filtering Circuit

The analog filtering circuit is designed for use with an electret microphone. Electret microphones typically require biasing, which is provided by MIC bias jumper, JP3. The analog signal generated by a typical electret microphone has a peak to peak voltage in the single millivolts range. The analog filtering circuit has a maximum gain of 300 which can be controlled with the potentiometer labeled **GAIN** and is a 2nd order low-pass filter with a cut-off frequency of 5 kHz. Jumper JP3 needs to be removed if the analog input is provided by input test point.

## 1.4.2 PWM Filtering from RC2

The microcontroller output RC2 provides an active low pass filter that can be used to generate analog signals. A high frequency PWM output from RC2 can be pulse width modulated to vary the amplitude of the output signal.

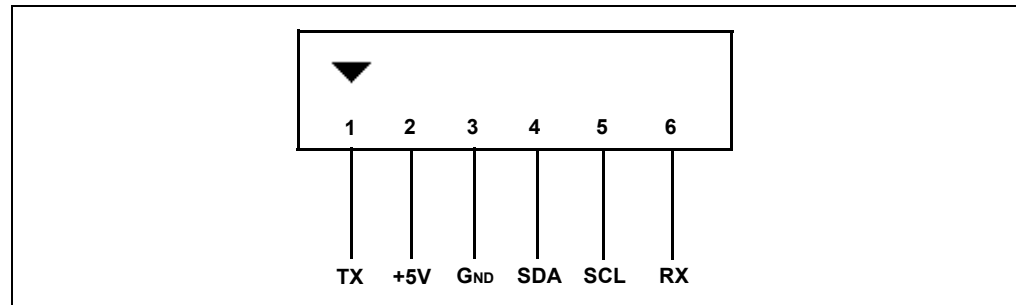
## 1.4.3 PICtail Daughter Board Interface

The PICtail daughter board interface breaks out each pin of the microcontroller in addition to providing +VDD and ground. The header is designed to be compatible with existing PICtail daughter boards. Visit the Microchip web site to find more details on PICtail daughter boards.

## 1.4.4 PICKit Serial Analyzer Connector

The PICKit serial analyzer connector provides pins for serial communication. The serial communications lines are designed to be used with the PICKit serial analyzer, but are also provided for general purpose communications as well. The Serial Communications pinout is shown below:

**FIGURE 1-2: SERIAL COMMUNICATIONS PIN-OUT**



## 1.4.5 ICSP™ (In-Circuit Serial Programmer™) Connector

A 6-pin ICSP programming capability and RJ-11 connectors are provided for programming the microcontroller. The PIC18F46K20 can be programmed through these connectors using the PICKit 2 programmer in the MPLAB ICD 2.

**Note:** The programming voltage on the microcontroller VPP pin must be below 9V according to the programming specification. Protection circuitry (8.2V Zener with 820 Ohm series resistor) is in place to ensure that VPP does not exceed programming specifications.

# PIC18F4XK20 Starter Kit User's Guide

---

## 1.4.6 Temperature Sensor

An MCP9700 temperature sensor is located on the board. The MCP9700 is an analog temperature sensor that provides a linear voltage output versus temperature. The voltage output of the temperature sensor is connected to the RE1 pin of the microcontroller.

## 1.4.7 25LC1024 Serial EEPROM

A Microchip 1024 Kbit serial reprogrammable Flash memory with both Flash and byte-level serial EEPROM functions is provided.

The memory is accessed via a simple Serial Peripheral Interface (SPI) compatible serial bus. The bus signals are a clock input plus separate data in and data out lines. Access to the device is controlled by a Chip Select (CS) input on the microcontroller pin RA6.

## 1.4.8 32.768 kHz Crystal

The 32.768 kHz tuning fork crystal is interfaced to the RC0/T1OSO and RC1/T1OSI pins for use with the Timer1 peripheral.

## 1.4.9 128x64 OLED

The display provided on the development board is a 128x64 organic LED display. It interfaces to the microcontroller via Serial Peripheral Interface (SPI). The controller on the OLED is the SH1101A.

## 1.5 POWERING THE DEMO BOARD

The demonstration board can be powered in the following ways:

1. The board accepts a 2.5mm coaxial power connector in J3. Acceptable voltages range from +5-12 VDC.
2. The PICkit 2 Development programmer can be used to provide power at connector P1. Do not exceed current of 100 mA on the board if the PICkit 2 is being used to power the board.
3. The PICkit Serial Analyzer can be used to provide power at connector P2. Do not exceed a current of 100 mA on the board if the PICkit Serial Analyzer is being used to power the board.

## 1.6 QUICK START GUIDE

The PIC18F4XK20 Starter Kit is preloaded with demonstration firmware. The board must be configured as described in this section in order to use the demonstration programs.

### Board Setup

1. Close jumper JP1 labeled **Current Jumper**, JP3 labeled **Mic Bias** and JP2.
2. Connect a +5-12V power supply to connector J3 in the upper left portion of the board.

### 1.6.1 Downloading Demonstration Software

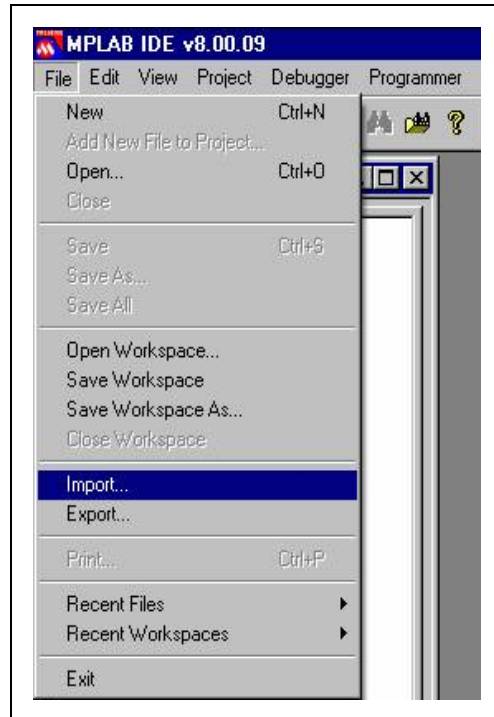
The PIC18F4XK20 Starter Kit CD-ROM comes with 3 demonstration programs and 12 hands-on programming lessons. Using the PICkit 2 Development Programmer, demonstration firmware can be downloaded onto the demo board and the board can be powered.

# PIC18F4XK20 Starter Kit Overview

---

1. Insert the included PIC18F4XK20 Demonstration Board CD into the CD-ROM Drive.
2. Run the installation setup for MPLAB IDE.
3. Connect the PICKit 2 programmer to the Starter Kit board and computer.
4. Start the MPLAB IDE software.
5. Click **File > Import**.

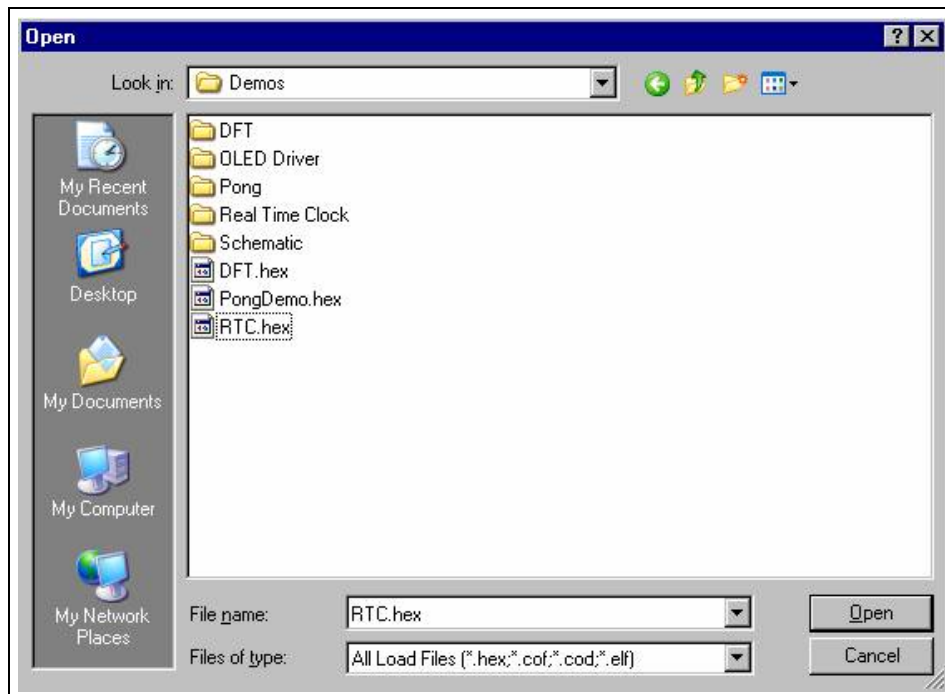
**FIGURE 1-3: IMPORT**



6. Browse to the CD-ROM drive directory *Demos*.
7. Select one of the several demos available (*readme.txt* in the *Demos* directory will describe each demo) and click **Open**:

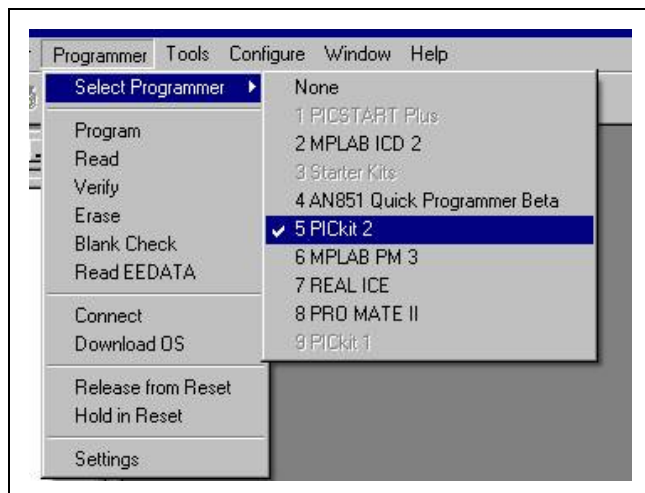
# PIC18F4XK20 Starter Kit User's Guide

FIGURE 1-4: DEMOS AVAILABLE



8. Click **Programmer** > **Select Programmer** > **PICKit 2**:

FIGURE 1-5:



9. To program, click **Programmer** > **Program**.
10. Click **Programmer** > **Release from Reset** to release the  $\overline{\text{MCLR}}$  to run the program.

## 1.7 PROGRAMMING LESSONS

The PIC18F4XK20 CD-ROM includes a variety of programming lessons designed for use with the demonstration board. Insert the PIC18F4XK20 CD-ROM and browse to the *Lessons* directory of the CD-ROM.

---

---

## **Chapter 2. Troubleshooting**

---

---

### **2.1 INTRODUCTION**

This chapter describes common problems when using the PIC18F4XK20 Demonstration Board and their solutions.

#### **2.1.1 The board does not power up.**

Make sure that the green POWER LED has turned on. If the LED is not on, check to see that the +9V power supply is properly connected.

#### **2.1.2 Microcontroller is not executing code.**

First check to make sure that the microcontroller has been programmed with the firmware that is intended to run. If the part is programmed, ensure that the current jumper JP1 is in place.

#### **2.1.3 The microcontroller will not program.**

Check to make sure that the programmer/debugger is properly connected to the PC and powered. Make sure that the board is also powered with the +9V power supply. Programming can only occur when the current jumper JP1 is connected.

# PIC18F4XK20 Starter Kit User's Guide

---

NOTES:

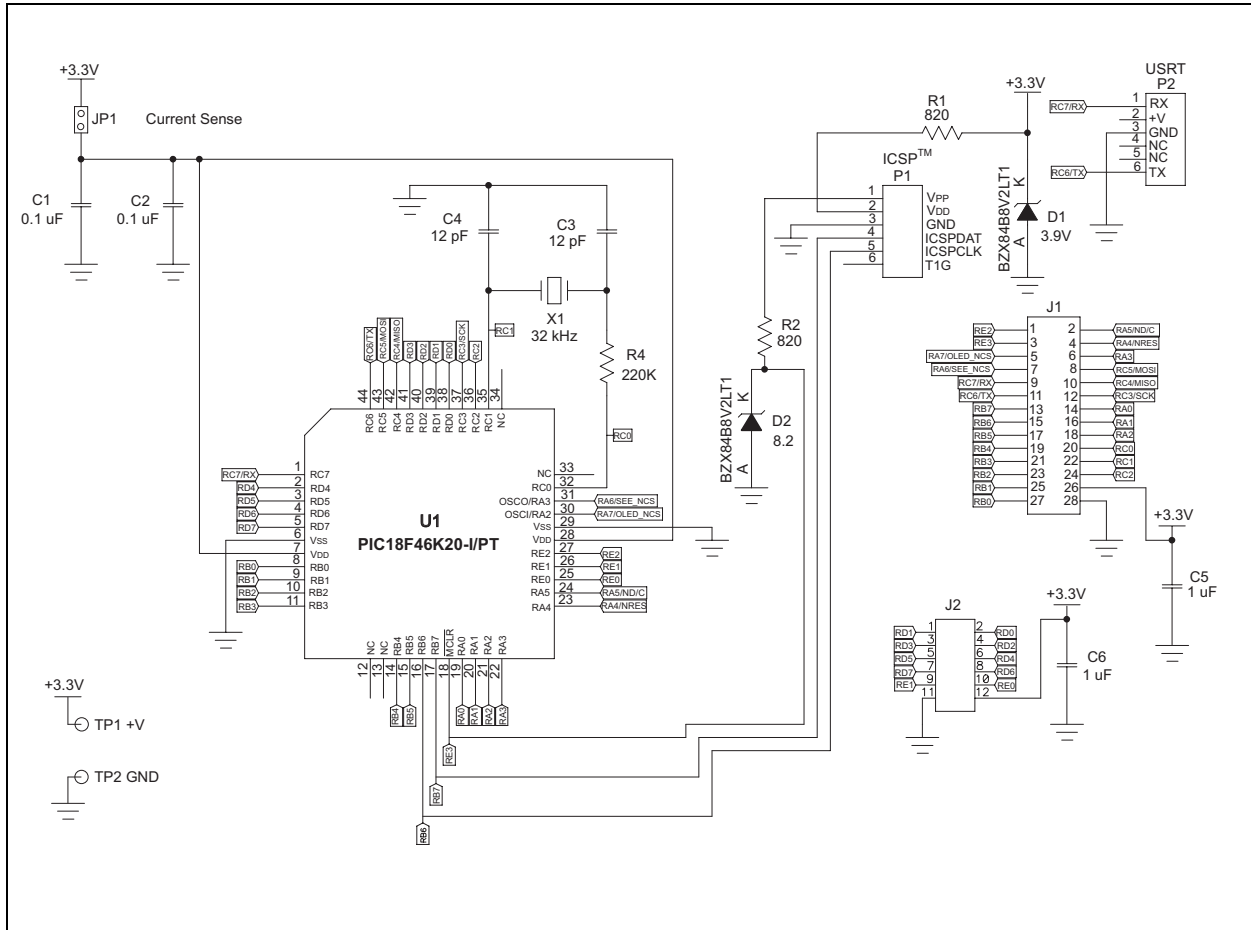


## Appendix A. Board Schematics

### A.1 INTRODUCTION

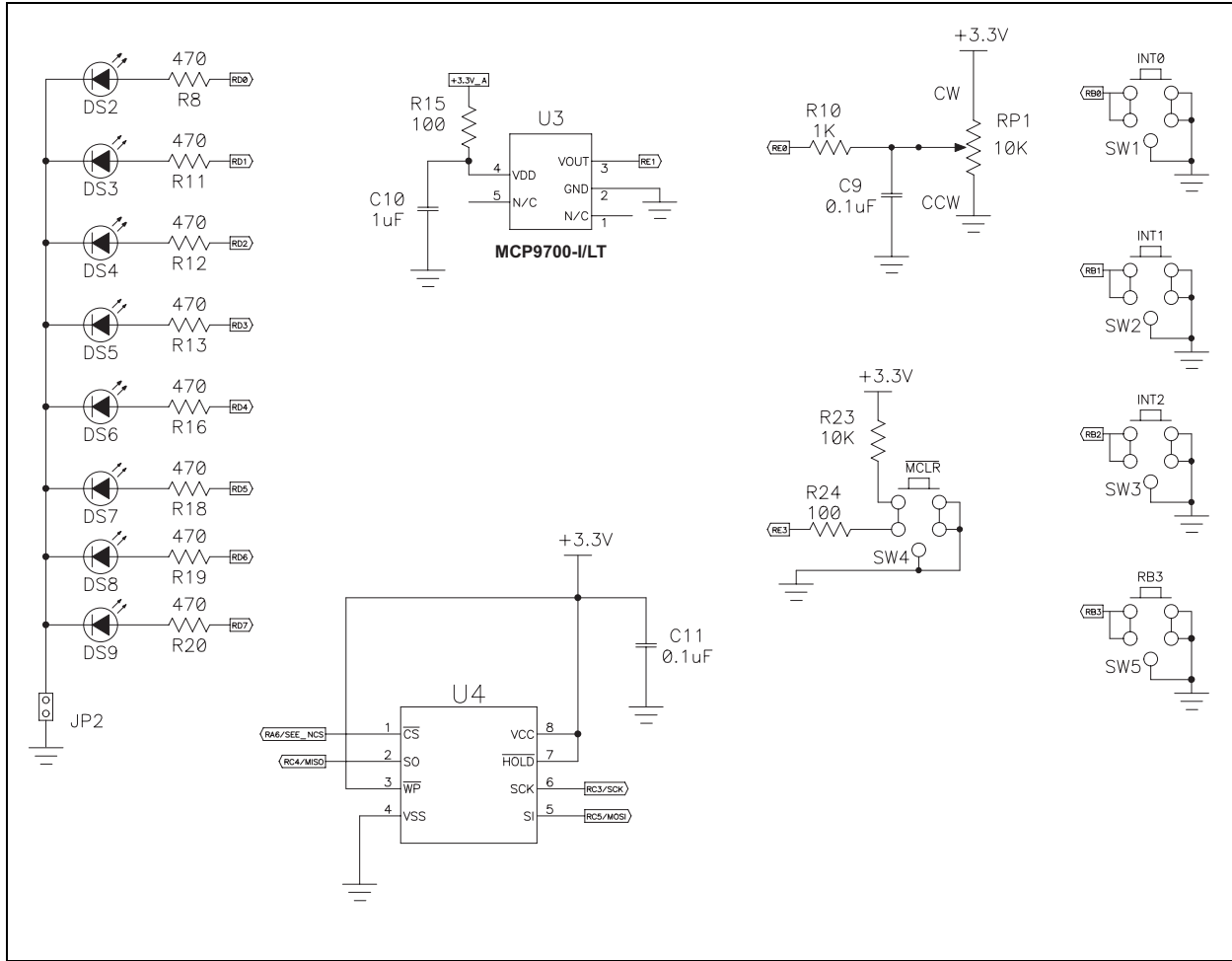
This appendix contains the PIC18F4XK20 demonstration board schematics, broken down into 5 sheets, as follows:

**FIGURE A-1: PIC18F4XK20 DEMO BOARD SCHEMATIC DIAGRAM (SHEET 1 OF 5)**

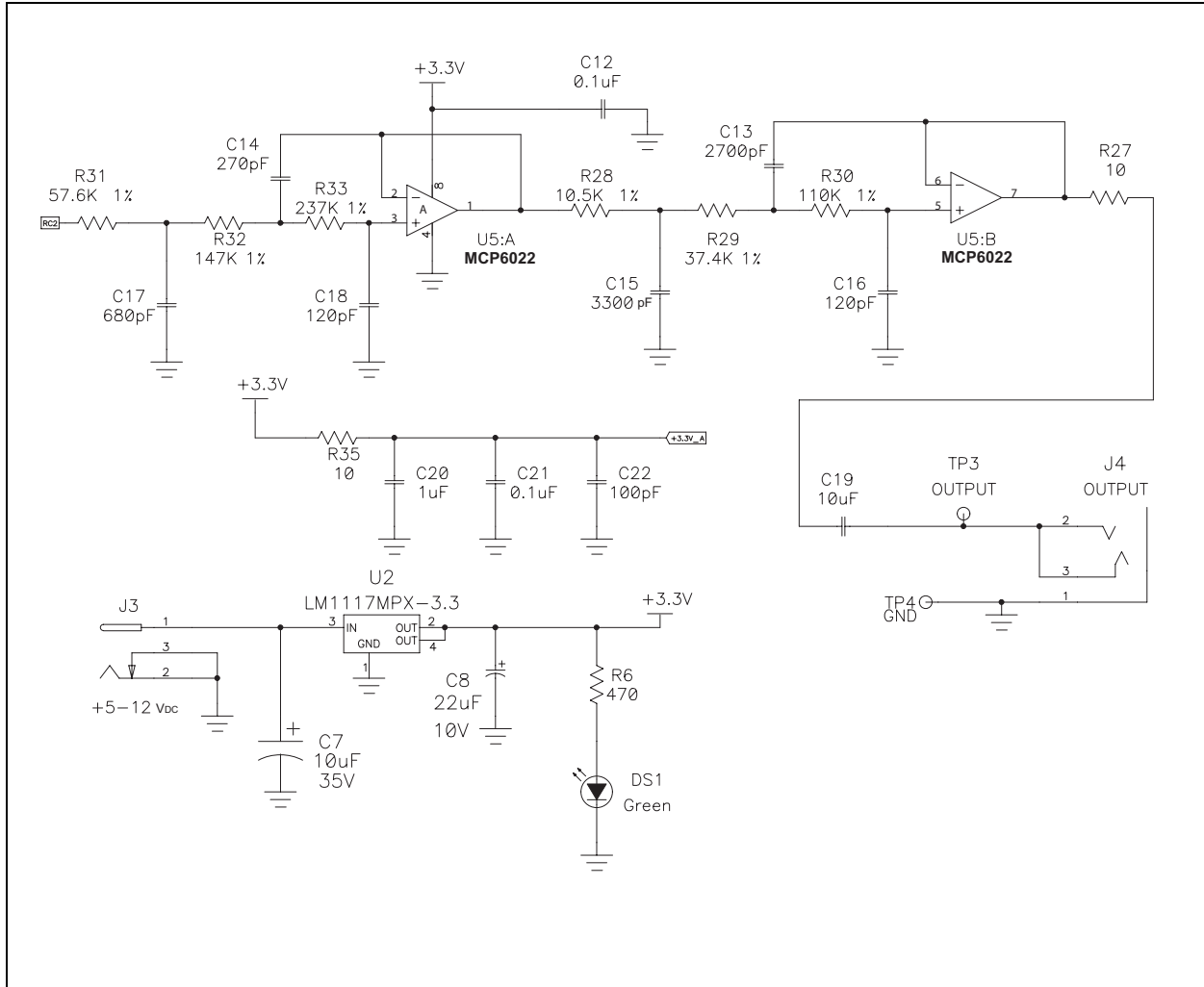


# PIC18F4XK20 Starter Kit User's Guide

**FIGURE A-2: PIC18F4XK20 DEMO BOARD SCHEMATIC DIAGRAM (SHEET 2 OF 5)**

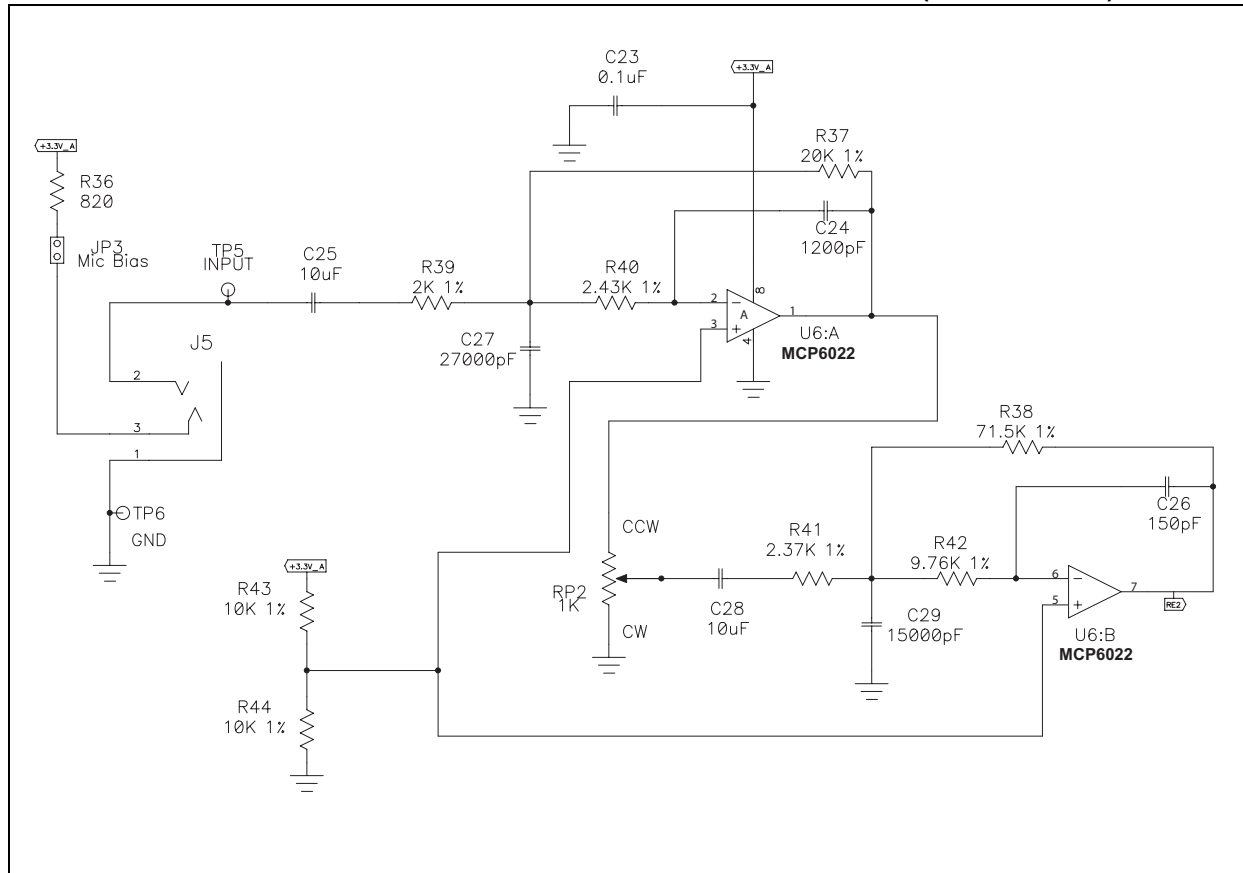


**FIGURE A-3: PIC18F4XK20 DEMO BOARD SCHEMATIC DIAGRAM (SHEET 3 OF 5)**

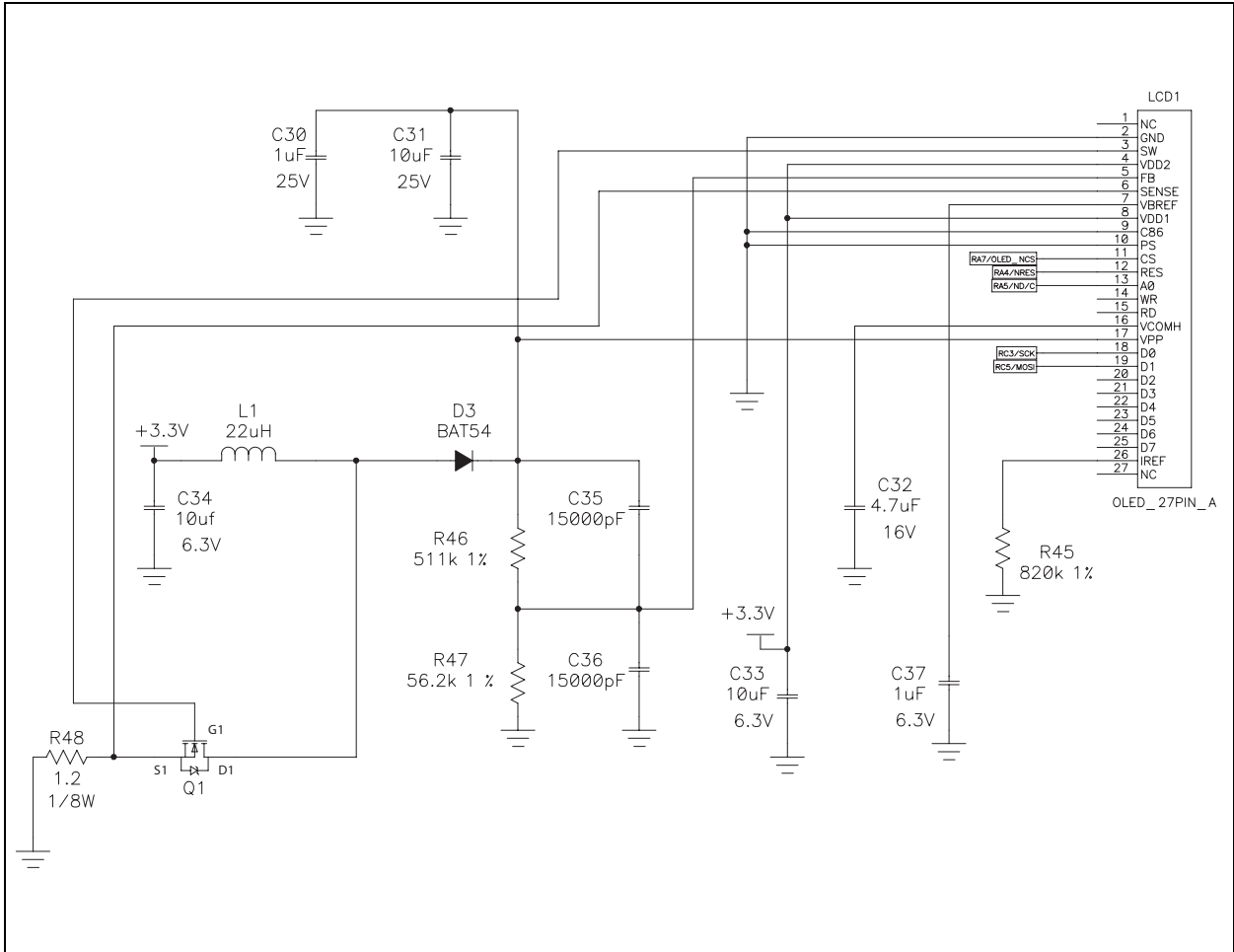


# PIC18F4XK20 Starter Kit User's Guide

FIGURE A-4: PIC18F4XK20 DEMO BOARD SCHEMATIC DIAGRAM (SHEET 4 OF 5)



**FIGURE A-5: PIC18F4XK20 DEMO BOARD SCHEMATIC DIAGRAM (SHEET 5 OF 5)**



# PIC18F4XK20 Starter Kit User's Guide

---

NOTES:

# PIC18F4XK20 Starter Kit User's Guide

---

---

NOTES:



---

---

## WORLDWIDE SALES AND SERVICE

---

---

### AMERICAS

**Corporate Office**  
2355 West Chandler Blvd.  
Chandler, AZ 85224-6199  
Tel: 480-792-7200  
Fax: 480-792-7277  
Technical Support:  
<http://support.microchip.com>  
Web Address:  
[www.microchip.com](http://www.microchip.com)

#### Atlanta

Duluth, GA  
Tel: 678-957-9614  
Fax: 678-957-1455

#### Boston

Westborough, MA  
Tel: 774-760-0087  
Fax: 774-760-0088

#### Chicago

Itasca, IL  
Tel: 630-285-0071  
Fax: 630-285-0075

#### Dallas

Addison, TX  
Tel: 972-818-7423  
Fax: 972-818-2924

#### Detroit

Farmington Hills, MI  
Tel: 248-538-2250  
Fax: 248-538-2260

#### Kokomo

Kokomo, IN  
Tel: 765-864-8360  
Fax: 765-864-8387

#### Los Angeles

Mission Viejo, CA  
Tel: 949-462-9523  
Fax: 949-462-9608

#### Santa Clara

Santa Clara, CA  
Tel: 408-961-6444  
Fax: 408-961-6445

#### Toronto

Mississauga, Ontario,  
Canada  
Tel: 905-673-0699  
Fax: 905-673-6509

### ASIA/PACIFIC

**Asia Pacific Office**  
Suites 3707-14, 37th Floor  
Tower 6, The Gateway  
Harbour City, Kowloon  
Hong Kong  
Tel: 852-2401-1200  
Fax: 852-2401-3431

**Australia - Sydney**  
Tel: 61-2-9868-6733  
Fax: 61-2-9868-6755

**China - Beijing**  
Tel: 86-10-8528-2100  
Fax: 86-10-8528-2104

**China - Chengdu**  
Tel: 86-28-8665-5511  
Fax: 86-28-8665-7889

**China - Hong Kong SAR**  
Tel: 852-2401-1200  
Fax: 852-2401-3431

**China - Nanjing**  
Tel: 86-25-8473-2460  
Fax: 86-25-8473-2470

**China - Qingdao**  
Tel: 86-532-8502-7355  
Fax: 86-532-8502-7205

**China - Shanghai**  
Tel: 86-21-5407-5533  
Fax: 86-21-5407-5066

**China - Shenyang**  
Tel: 86-24-2334-2829  
Fax: 86-24-2334-2393

**China - Shenzhen**  
Tel: 86-755-8203-2660  
Fax: 86-755-8203-1760

**China - Wuhan**  
Tel: 86-27-5980-5300  
Fax: 86-27-5980-5118

**China - Xiamen**  
Tel: 86-592-2388138  
Fax: 86-592-2388130

**China - Xian**  
Tel: 86-29-8833-7252  
Fax: 86-29-8833-7256

**China - Zhuhai**  
Tel: 86-756-3210040  
Fax: 86-756-3210049

### ASIA/PACIFIC

**India - Bangalore**  
Tel: 91-80-4182-8400  
Fax: 91-80-4182-8422

**India - New Delhi**  
Tel: 91-11-4160-8631  
Fax: 91-11-4160-8632

**India - Pune**  
Tel: 91-20-2566-1512  
Fax: 91-20-2566-1513

**Japan - Yokohama**  
Tel: 81-45-471- 6166  
Fax: 81-45-471-6122

**Korea - Daegu**  
Tel: 82-53-744-4301  
Fax: 82-53-744-4302

**Korea - Seoul**  
Tel: 82-2-554-7200  
Fax: 82-2-558-5932 or  
82-2-558-5934

**Malaysia - Kuala Lumpur**  
Tel: 60-3-6201-9857  
Fax: 60-3-6201-9859

**Malaysia - Penang**  
Tel: 60-4-227-8870  
Fax: 60-4-227-4068

**Philippines - Manila**  
Tel: 63-2-634-9065  
Fax: 63-2-634-9069

**Singapore**  
Tel: 65-6334-8870  
Fax: 65-6334-8850

**Taiwan - Hsin Chu**  
Tel: 886-3-572-9526  
Fax: 886-3-572-6459

**Taiwan - Kaohsiung**  
Tel: 886-7-536-4818  
Fax: 886-7-536-4803

**Taiwan - Taipei**  
Tel: 886-2-2500-6610  
Fax: 886-2-2508-0102

**Thailand - Bangkok**  
Tel: 66-2-694-1351  
Fax: 66-2-694-1350

### EUROPE

**Austria - Wels**  
Tel: 43-7242-2244-39  
Fax: 43-7242-2244-393

**Denmark - Copenhagen**  
Tel: 45-4450-2828  
Fax: 45-4485-2829

**France - Paris**  
Tel: 33-1-69-53-63-20  
Fax: 33-1-69-30-90-79

**Germany - Munich**  
Tel: 49-89-627-144-0  
Fax: 49-89-627-144-44

**Italy - Milan**  
Tel: 39-0331-742611  
Fax: 39-0331-466781

**Netherlands - Drunen**  
Tel: 31-416-690399  
Fax: 31-416-690340

**Spain - Madrid**  
Tel: 34-91-708-08-90  
Fax: 34-91-708-08-91

**UK - Wokingham**  
Tel: 44-118-921-5869  
Fax: 44-118-921-5820