

Chip Trimmer Potentiometers

MVR34

The MVR34 chip trimmer potentiometer is designed for use in automatic regulators. With its highly stable and reliable ruthenium oxide resistor on an alumina substrate, it offers outstanding dependability in a small, lightweight package.

●Features

- 1) Excellent for use in automatic regulators.
- 2) Easy to set manually using a regular phillips screwdriver.
- 3) Superb solder ability thanks to extra soldering electrode.
- 4) Close match between wiper and dielectric reduces noise.
- 5) Mounting can be automated by using a carrier tape.
- 6) Two-digit markings used to indicate resistance.
- 7) ROHM resistors have approved ISO9001- / ISO/TS 16949- certification.

Design and specifications are subject to change without notice. Carefully check the specification sheet before using or ordering it.

●Ratings

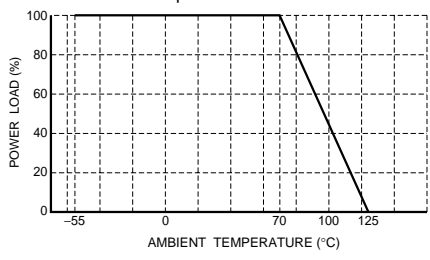
Item	Conditions	Specifications
Rated power	<p>Power must be derated according to the power derating curve in Figure 1 when ambient temperature exceeds 70°C.</p>  <p style="text-align: center;">Fig.1</p>	0.1W (1 / 10W) / element at 70°C
Rated voltage	<p>The voltage rating is calculated by the following equation. If the value obtained exceeds the maximum operating voltage, the voltage rating is equal to the maximum operating voltage.</p> $E = \sqrt{P \times R}$ <p style="margin-left: 40px;">E: Rated voltage (V) P: Rated power (W) R: Nominal resistance (Ω)</p>	Max. operating voltage: 50V
Nominal total resistance range		100 to 1MΩ (recommended resistance value: E3 series) (applicable resistance value: E6 series)
Total resistance tolerance		±25%
Resistance variation		B (linear) characteristics
Effective rotation angle		220±20°
Operating temperature		-55°C to +125°C
Reactive variable	Rotational angle, both ends	within 10% (R > 150Ω) within 20% (R ≤ 150Ω)

●Before using components in circuits where they will be exposed to transients such as pulse loads (short-duration, high-level loads), be certain to evaluate the component in the mounted state. In addition, the reliability and performance of this component cannot be guaranteed if it is used with a steady state voltage that is greater than its rated voltage.

●The remainder of flux may negatively affect product performance and reliability. So please make sure to wash and remove flux completely washing.

Resistors

●Characteristics

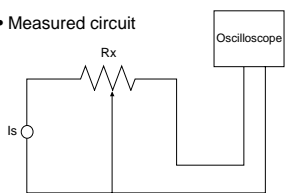
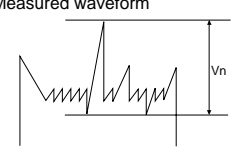
Characteristics	Specifications	Test method (JIS C 5261)
DC total resistance	Within $\pm 25\%$	JIS C 5261 5.1
Contact resistance rate	3% or less	JIS C 5261 5.9
Resistance change characteristics	B group OB	JIS C 5261 5.1 Voltage method
Residual resistance	R < 1k Ω 20 Ω or less R \geq 1k Ω Within 2% of total nominal resistance	JIS C 5261 5.1
Wiper noise	5% or less of total nominal resistance, within the effective rotational range	JIS C 5261 5.8 B method Rotational speed of approx. 10 cycles per minute (with one cycle defined as one round trip) <ul style="list-style-type: none"> Measured circuit  <ul style="list-style-type: none"> Measured waveform  <p>Provided that the constant current has been set according to the following: Is: $I_s = \frac{10}{R_x}$ (When $R_x \leq 1k\Omega$, constant current is defined as $I_s=10mA$) Rx: Nominal resistance of semi-fixed test resistor. Vn: Noise voltage Noise rate = $= \frac{V_n}{I_s \times R_x} \times 100 (\%)$</p>
Resistance temperature characteristics	$\pm 250ppm / ^\circ C$	JIS C 5261 5.3 +25 / -55 / +25 / +125 $^\circ C$
Resistance to dry heat	Total resistance change rate: $\pm (5.0\%+0.1\Omega)$ Constriction contact resistance rate: 8% or less	JIS C 5261 7.2 125 $^\circ C$ Test time: 1,000 to 1,048 hrs.
Temperature cycling	Total resistance change rate: $\pm (5.0\%+0.1\Omega)$ Constriction contact resistance rate: 8% or less	JIS C 5261 7.3 Test temperature: -55 $^\circ C$ to +125 $^\circ C$ 100cyc.
Resistance to humidity (steady state)	Total resistance change rate: $\pm (5.0\%+0.1\Omega)$ Constriction contact resistance rate: 8% or less	JIS C 5261 7.4 60 $^\circ C$, 95%RH Test time: 1,000 to 1,048 hrs.
Endurance (under load in damp environment)	Total resistance change rate: $\pm (5.0\%+0.1\Omega)$ Constriction contact resistance rate: 8% or less	JIS C 5261 7.6 Rated voltage (current), 60 $^\circ C$, 95%RH 1.5h: ON - 0.5h: OFF Test time: 1,000 to 1,048 hrs.
Endurance (steady state)	Total resistance change rate: $\pm (5.0\%+0.1\Omega)$ Constriction contact resistance rate: 8% or less	JIS C 5261 7.7 Rated voltage (current), 70 $^\circ C$ 1.5h: ON - 0.5h: OFF Test time: 1,000 to 1,048 hrs.
Rotational torque	1.9-19.7mN · m (20-200gf · cm)	JIS C 5261 6.2
Endurance (wiper)	Total resistance change rate: Within $\pm 15\%$ Constriction contact resistance rate: 8% or less	JIS C 5261 7.8 After 20 rotations

Resistors

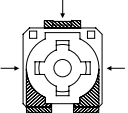
Characteristics	Specifications	Test method (JIS C 5261)
Terminal strength (compression)	Total resistance change rate: $\pm (3.0\%+0.1\Omega)$ There must be no mechanical damage. 	JIS C 5261 6.5 Force (4.9N) is applied from three directions upon the middle of the sides of the sample on the surface being tested, as shown in the illustration on the left.
Terminal strength (bending)	Total resistance change rate: $\pm (3.0\%+0.1\Omega)$ There must be no mechanical damage.	JIS C 5261 6.5 Duration of pressure: 5 ± 1 s. Amount of bending: 3mm
Resistance to soldering heat	Total resistance change rate: $\pm (3.0\%+0.1\Omega)$ Constriction contact resistance rate: 5% or less	JIS C 5261 6.7 Soldering conditions: $260\pm 5^\circ\text{C}$ Soldering time: 10 ± 1 s.
Solderability	95% of terminal surface must be covered by new soldering, and there must be no soldering corrosion.	JIS C 5261 6.8 Flux: Rosin methanol or rosin isopropyl alcohol Solder: H63A Soldering conditions: $235\pm 5^\circ\text{C}$ Soldering time: 2.0 ± 0.5 s.

●Dimensions (Unit: mm)

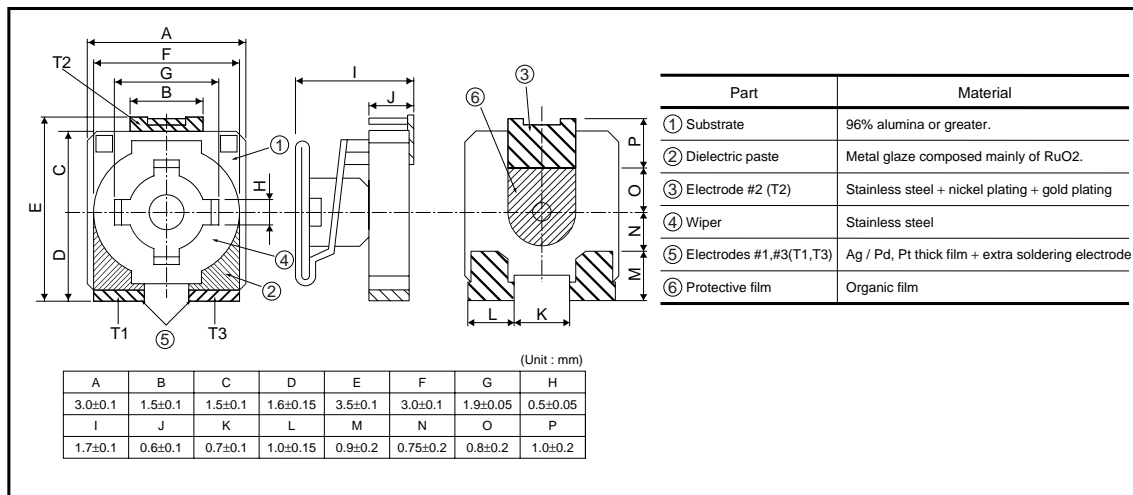

●Equivalent circuit

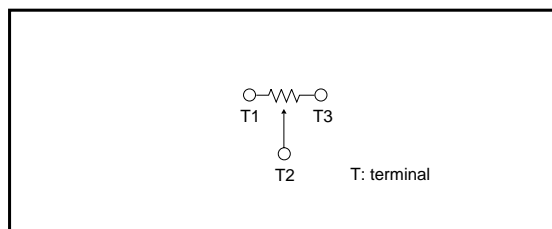

Resistors

●Packaging

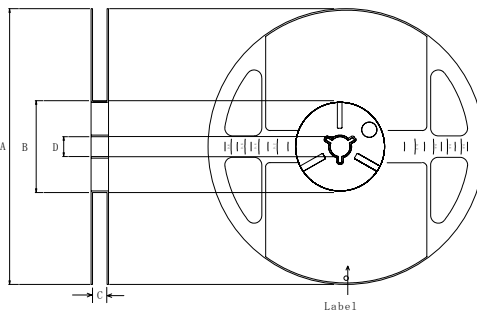
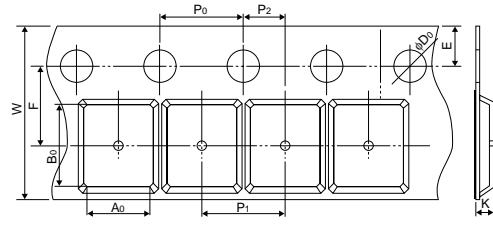
Reel	Taping																												
 <p style="text-align: center;">EIAJ ET-7200B compliant</p> <p style="text-align: center;">(Unit : mm)</p> <table border="1" style="margin-left: auto; margin-right: auto;"> <tr> <th>A</th> <th>B</th> <th>C</th> <th>D</th> </tr> <tr> <td>$\phi 180 \begin{smallmatrix} 0 \\ -1.5 \end{smallmatrix}$</td> <td>$\phi 60 \begin{smallmatrix} +1 \\ 0 \end{smallmatrix}$</td> <td>$9 \begin{smallmatrix} +1.0 \\ 0 \end{smallmatrix}$</td> <td>$\phi 13 \pm 0.2$</td> </tr> </table>	A	B	C	D	$\phi 180 \begin{smallmatrix} 0 \\ -1.5 \end{smallmatrix}$	$\phi 60 \begin{smallmatrix} +1 \\ 0 \end{smallmatrix}$	$9 \begin{smallmatrix} +1.0 \\ 0 \end{smallmatrix}$	$\phi 13 \pm 0.2$	 <p style="text-align: center;">(Unit : mm)</p> <table border="1" style="margin-left: auto; margin-right: auto;"> <tr> <th>W</th> <th>F</th> <th>E</th> <th>A₀</th> <th>B₀</th> </tr> <tr> <td>8.0±0.2</td> <td>3.5±0.05</td> <td>1.75±0.1</td> <td>3.3±0.2</td> <td>3.8±0.2</td> </tr> <tr> <th>D₀</th> <th>P₀</th> <th>P₁</th> <th>P₂</th> <th>K</th> </tr> <tr> <td>$\phi 1.5 \begin{smallmatrix} +0.1 \\ 0 \end{smallmatrix}$</td> <td>4.0±0.1</td> <td>4.0±0.1</td> <td>2.0±0.05</td> <td>2.2±0.3</td> </tr> </table>	W	F	E	A ₀	B ₀	8.0±0.2	3.5±0.05	1.75±0.1	3.3±0.2	3.8±0.2	D ₀	P ₀	P ₁	P ₂	K	$\phi 1.5 \begin{smallmatrix} +0.1 \\ 0 \end{smallmatrix}$	4.0±0.1	4.0±0.1	2.0±0.05	2.2±0.3
A	B	C	D																										
$\phi 180 \begin{smallmatrix} 0 \\ -1.5 \end{smallmatrix}$	$\phi 60 \begin{smallmatrix} +1 \\ 0 \end{smallmatrix}$	$9 \begin{smallmatrix} +1.0 \\ 0 \end{smallmatrix}$	$\phi 13 \pm 0.2$																										
W	F	E	A ₀	B ₀																									
8.0±0.2	3.5±0.05	1.75±0.1	3.3±0.2	3.8±0.2																									
D ₀	P ₀	P ₁	P ₂	K																									
$\phi 1.5 \begin{smallmatrix} +0.1 \\ 0 \end{smallmatrix}$	4.0±0.1	4.0±0.1	2.0±0.05	2.2±0.3																									

●Part No. Explanation

Part No.

M

V

R

3

4

H

X

B

R

N

⏟

Packaging / Processing specifications

⏟



Resistance tolerance

⏟

Nominal resistance

Code	Part No.	Soldering	Packaging specifications	Reel	Basic ordering unit (pcs)	N	±25%	3-digit IEC coding system
HXBR	MVR34	Reflow soldering	Embossed tape (4mm Pitch)	φ180mm (7in)	2,000			

●Recommended screwdriver for adjusting MVR resistors

Model	Open, type 3
	MVR34
Dimensions, configuration	Manual adjustment, automatic adjustment
	 
Commercially sold product (Maker)	No.9000 (+)0x30 [Vessel] No.205 (+)No.0 [Vessel]

Notes

- No technical content pages of this document may be reproduced in any form or transmitted by any means without prior permission of ROHM CO.,LTD.
- The contents described herein are subject to change without notice. The specifications for the product described in this document are for reference only. Upon actual use, therefore, please request that specifications to be separately delivered.
- Application circuit diagrams and circuit constants contained herein are shown as examples of standard use and operation. Please pay careful attention to the peripheral conditions when designing circuits and deciding upon circuit constants in the set.
- Any data, including, but not limited to application circuit diagrams information, described herein are intended only as illustrations of such devices and not as the specifications for such devices. ROHM CO.,LTD. disclaims any warranty that any use of such devices shall be free from infringement of any third party's intellectual property rights or other proprietary rights, and further, assumes no liability of whatsoever nature in the event of any such infringement, or arising from or connected with or related to the use of such devices.
- Upon the sale of any such devices, other than for buyer's right to use such devices itself, resell or otherwise dispose of the same, no express or implied right or license to practice or commercially exploit any intellectual property rights or other proprietary rights owned or controlled by
- ROHM CO., LTD. is granted to any such buyer.
- Products listed in this document are no antiradiation design.

The products listed in this document are designed to be used with ordinary electronic equipment or devices (such as audio visual equipment, office-automation equipment, communications devices, electrical appliances and electronic toys).

Should you intend to use these products with equipment or devices which require an extremely high level of reliability and the malfunction of which would directly endanger human life (such as medical instruments, transportation equipment, aerospace machinery, nuclear-reactor controllers, fuel controllers and other safety devices), please be sure to consult with our sales representative in advance.

About Export Control Order in Japan

Products described herein are the objects of controlled goods in Annex 1 (Item 16) of Export Trade Control Order in Japan.

In case of export from Japan, please confirm if it applies to "objective" criteria or an "informed" (by MITI clause) on the basis of "catch all controls for Non-Proliferation of Weapons of Mass Destruction.