

ZigBee OEM Module

ProBee-ZE20S

Datasheet

Sena Technologies, Inc.

Rev 1.0.0

ProBee-ZE20S Datasheet

Copyright

Copyright 2011 Sena Technologies, Inc. All rights reserved.

Sena Technologies reserves the right to make changes and improvements to its product without providing notice.

Trademark

ProBee™ is a trademark of Sena Technologies, Inc.

Notice to Users

When a system failure may cause serious consequences, protecting life and property against such consequences with a backup system or safety device is essential. The user agrees that protection against consequences resulting from system failure is the user's responsibility.

This device is not approved for life-support or medical systems.

Changes or modifications to this device not explicitly approved by Sena Technologies will void the user's authority to operate this device.

Contents

1	General	4
1.1	About This Document.....	4
1.2	Overview.....	4
1.3	Device Diagram	5
1.4	Pin Diagram	6
1.5	Pin Descriptions	7
1.6	Mechanical Drawings	8
1.7	Recommended PCB Layout	10
2	Electrical Characteristics	11
2.1	Absolute Maximum Ratings.....	11
2.2	Recommended Operating Conditions.....	11
2.3	Power Consumptions	11
2.4	Digital I/O Specifications.....	12
2.5	ADC Specifications	12
3	RF Characteristics	13
3.1	Transmitter Characteristics.....	13
3.2	Receive Characteristics.....	13
4	Device Terminal Descriptions	14
4.1	UART Mode	14
4.2	Reset.....	14
4.3	GPIO	15
4.4	JTAG	15
5	Application Schematics	16
6	Contact Information	19

1 General

1.1 About This Document

This document provides detail information and specifications of the ProBee-ZE20S ZigBee OEM module. This document does not provide software and usage guide of the ZE20S. For more information on the software and usage guide, please refer to the separate ProBee-ZE20S Users Guide.

1.2 Overview

The ProBee-ZE20S is an all-in-one ZigBee OEM module with integrated ZigBee core and radio/antenna circuits together with high level software library. Using the ZE20S, OEM manufacturers can easily and cost-effectively integrate ZigBee functionality into target products in timely manner.

The ZE20S OEM module is designed to meet specific requirements of low cost and low power wireless applications such as home automation or smart energy by adopting the ZigBee technology. The ZE20S is based on the Ember EM357 ZigBee core and fully certified under the latest ZigBee Pro standard for the maximum compatibility.

Despite of its low cost and low power consumptions, the ZE20S provides high performance and robust data transfer capability for wide range of applications. The ZE20S can transfer data at up to 250 kbps and reach up to 1.0 km (0.62 miles) outdoor line-of-sight.

Key Features

- Integrated 2.4GHz, IEEE 802.15.4-2003 compliant transceiver
- ZigBee Pro Certified
- ZigBee core: Ember EM357
- Transmit Power: +8dBm (Boost mode)
- Receiver Sensitivity: -102dBm @1% BER (Boost mode)
- TX Current: 45mA @3.3V (max.)
- RX Current: 31mA @3.3V (max.)
- Sleep Current: $\leq 2\mu\text{A}$
- Working Distance: 1.0 km (0.62 miles) @ 3.3V, +5dBi Dipole Antenna
- Various Antenna/Connector Options: Dipole 1/3/5dBi, U.FL, RPSMA, Chip
- UART Signals Support: UART_TXD/RXD, RTS/CTS, DTR/DSR
- 6 Analog Inputs
- 17 Digital Inputs/Outputs
- RoHS Compliant

Applications

- Advanced Metering Infrastructure
- Home Area Networks (HAN)
- Neighborhood Area Networks (NAN)
- Home Automation
- Advanced lighting, entertainment, and climate control systems
- Service-based monitoring, security, and awareness systems
- Commercial Building Automation
- Climate & lighting control systems
- Industrial and Domestic Applications

1.3 Device Diagram

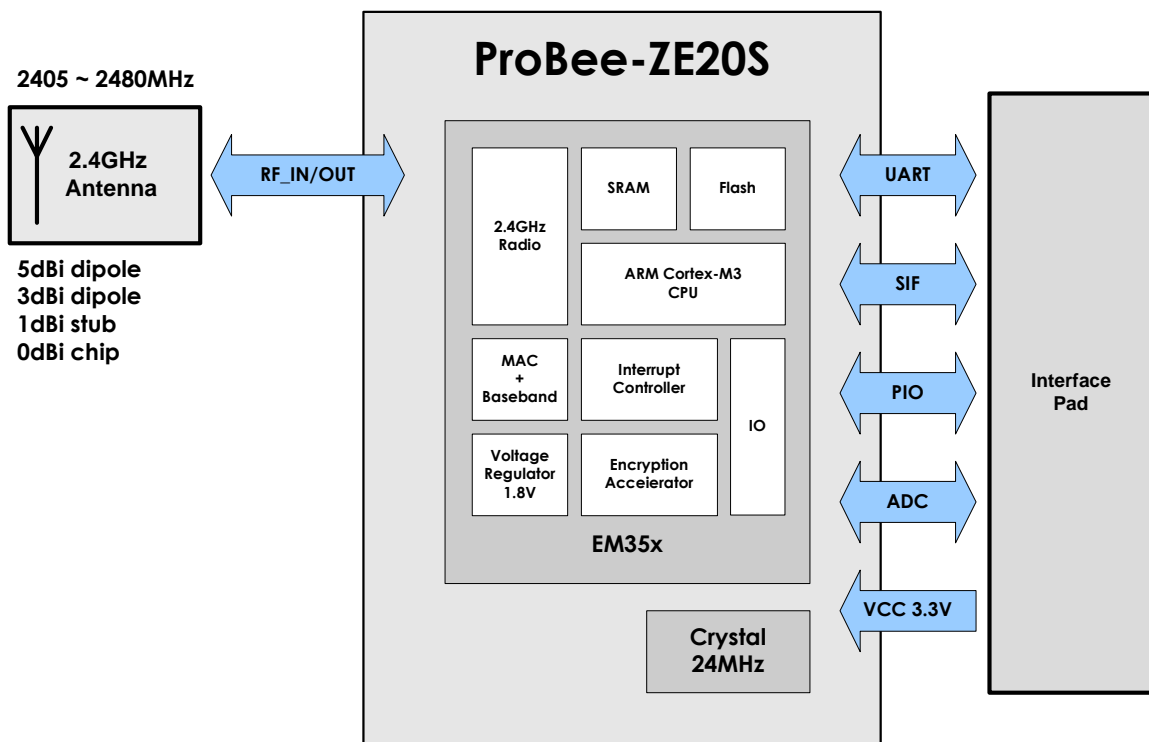
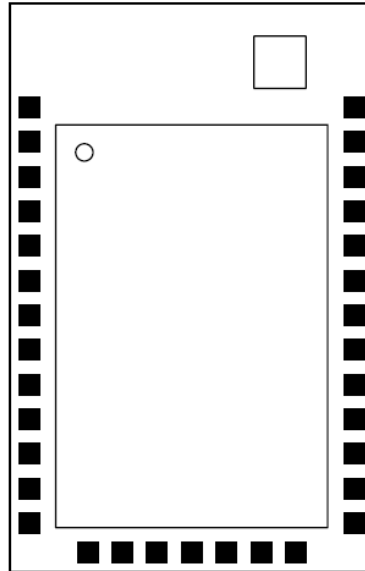

Figure 1-1 Device Diagram

1.4 Pin Diagram

NO	Pin Assignment
1	GND
2	PC_5/FACTORY_RST
3	PC_6/GPIO0
4	PC_7/DTR/GPIO1
5	PA_7/DSR/GPIO2
6	PB_3/CTS/GPIO3
7	PB_4/RTS/GPIO4
8	PA_0/MOSI/GPIO5
9	PA_1/MISO/GPIO6
10	PA_2/SCLK/GPIO7
11	PA_3/nSSEL/GPIO8
12	VCC
13	GND



Pin Assignment	NO
GND	33
PB_5/ADC0/GPIO9	32
PB_6/ADC1/GPIO10	31
PB_7/ADC2/GPIO11	30
PC_1/ADC3/GPIO12	29
PA_4/ADC4/GPIO13	28
PA_5/ADC5/GPIO14	27
PB_1/TXD	26
PB_2/RXD	25
PB_0/GPIO15	24
PA_6/GPIO16	23
/RESET	22
GND	21

14	VCC
15	JTCK
16	PC_2/JTDO
17	PC_3/JTDI
18	PC_4/JTMS
19	PC_0/JRST
20	GND

Figure 1-2 Pin Diagram

1.5 Pin Descriptions

Table 1-1 Pin Descriptions

Pin	NAME	Default Function	Direction	Description
1	GND	-	-	Ground
2	Factory Reset	Factory Reset	IN	Digital I/O, Factory reset input, Active low
3	GPIO_0	DIO_0	IN/OUT	Digital I/O, Permit joining input
4	GPIO_1	DIO_1	IN/OUT	Digital I/O, UART_DTR
5	GPIO_2	DIO_2	IN/OUT	Digital I/O, UART_DSR
6	GPIO_3	DIO_3	IN/OUT	Digital I/O, UART_CTS
7	GPIO_4	DIO_4	IN/OUT	Digital I/O, UART_RTS
8	GPIO_5	DIO_5	IN/OUT	Digital I/O
9	GPIO_6	DIO_6	IN/OUT	Digital I/O
10	GPIO_7	DIO_7	IN/OUT	Digital I/O
11	GPIO_8	DIO_8	IN/OUT	Digital I/O
12	VCC	-	-	Power Supply, 3.3V
13	GND	-	-	Ground
14	VCC	-	-	Power Supply, 3.3V
15	JTCK	-	IN	JTAG clock input from debugger
16	JTDO	-	OUT	JTAG data output to debugger
17	JTDI	-	IN	JTAG data input from debugger
18	JTMS	-	IN	JTAG mode select from debugger
19	JRST	-	IN	JTAG reset input from debugger
20	GND	-	-	Ground
21	GND	-	-	Ground
22	/RESET	-	IN	H/W_/Reset, Active low
23	GPIO_16	DIO_16	IN/OUT	Digital I/O, Status LED
24	GPIO_15	DIO_15	IN/OUT	Digital I/O, Power LED
25	UART_RXD	UART_RXD	IN	UART Data Input
26	UART_TXD	UART_TXD	OUT	UART Data Output
27	GPIO_14	DIO_14	IN/OUT	Digital I/O / ADC_5
28	GPIO_13	DIO_13	IN/OUT	Digital I/O / ADC_4
29	GPIO_12	DIO_12	IN/OUT	Digital I/O / ADC_3
30	GPIO_11	DIO_11	IN/OUT	Digital I/O / ADC_2
31	GPIO_10	DIO_10	IN/OUT	Digital I/O / ADC_1
32	GPIO_9	DIO_9	IN/OUT	Digital I/O / ADC_0
33	GND	-	-	Ground

1.6 Mechanical Drawings

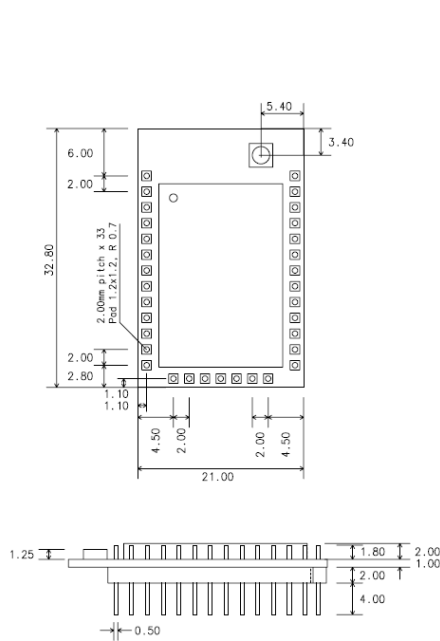

Figure 1-3 ProBee-ZE20SDU

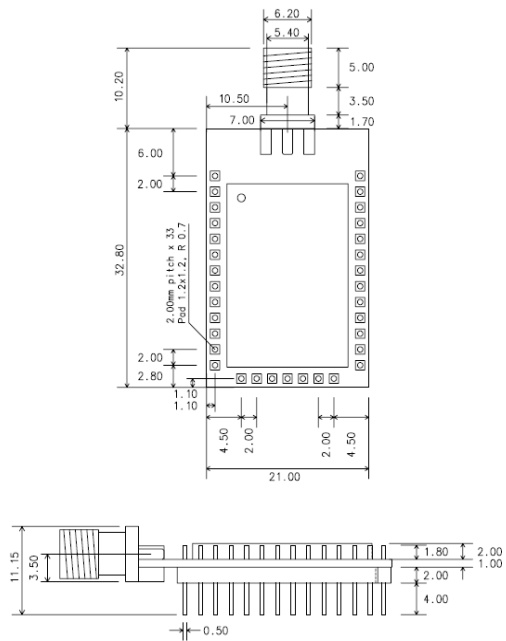

Figure 1-4 ProBee-ZE20SDS

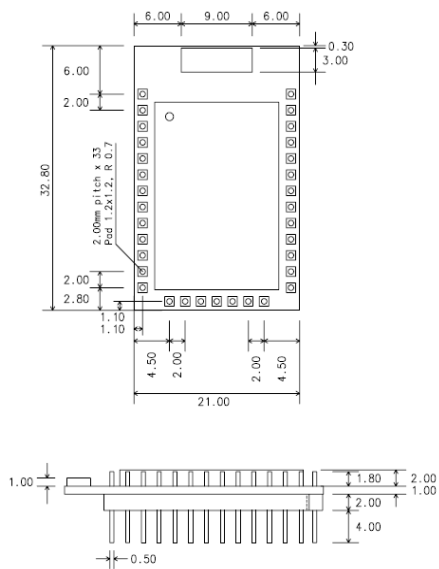

Figure 1-5 ProBee-ZE20SDC

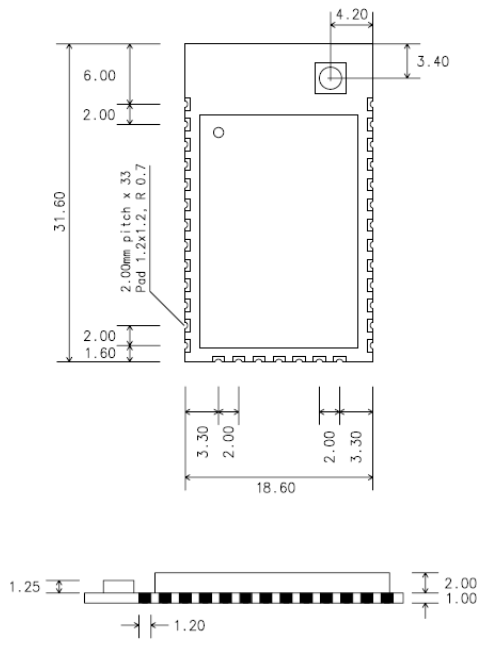

Figure 1-6 ProBee-ZE20SSU

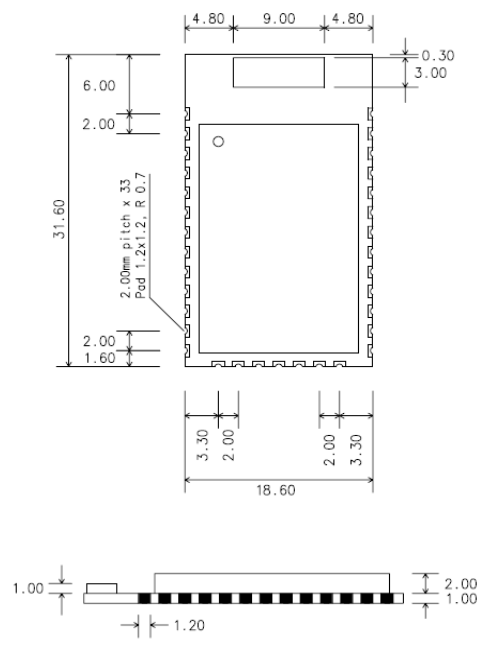
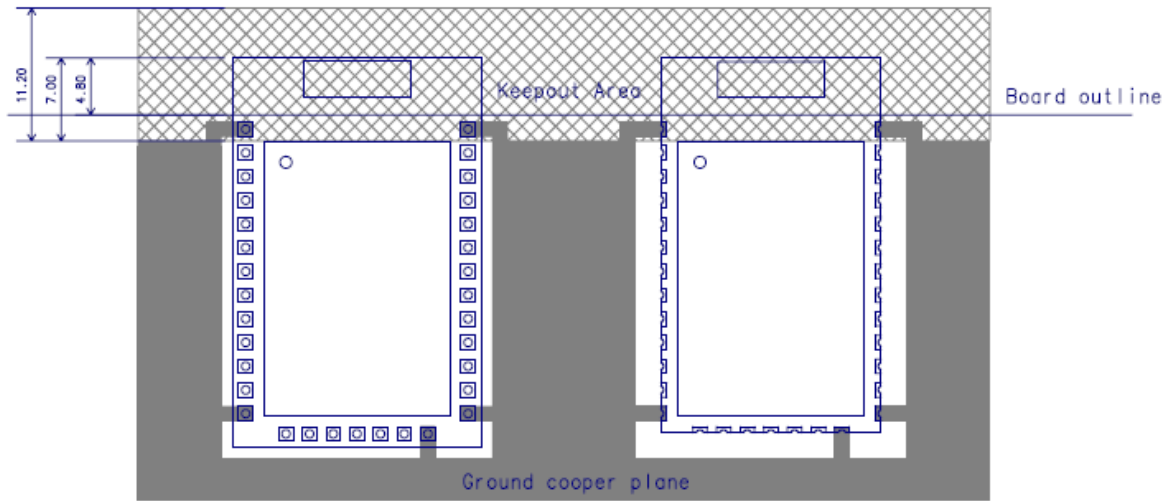
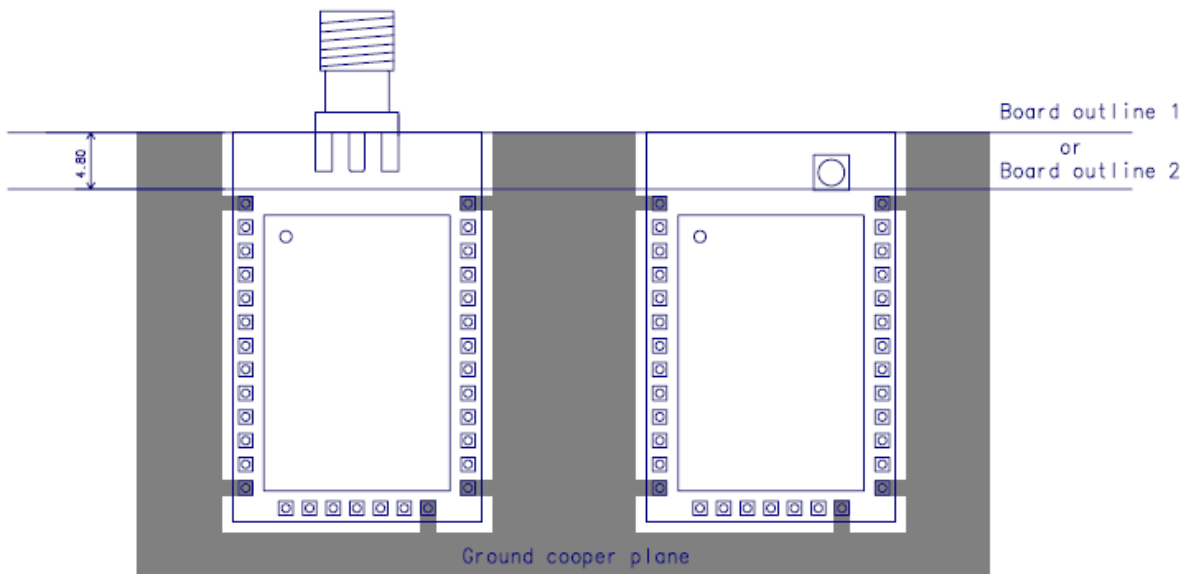

Figure 1-7 ProBee-ZE20SSC

1.7 Recommended PCB Layout



Chip antenna type



RF connector type

Figure 1-8 Recommended PCB Layout

2 Electrical Characteristics

2.1 Absolute Maximum Ratings

Table 2-1 Absolute Maximum Ratings

Ratings		Min	Max	Unit
Storage Temperature		-40	+85	°C
Operating Temperature		-40	+85	°C
Supply voltage	VCC	2.1	3.6	V
	GPIO INPUT	-0.3	3.6	V
	ADC INPUT	-	1.21	V
Other terminal voltages		GND – 0.3	VCC + 0.3	V

2.2 Recommended Operating Conditions

Table 2-2 Recommended Operating Conditions

Ratings		Min	Typ.	Max	Unit
Operating Temperature		-30	25	+70	°C
Supply voltage	VCC	3.0	3.3	-	V
	GPIO INPUT	3.0	3.3	-	V
	ADC INPUT	-	1.2	-	V

2.3 Power Consumptions

Table 2-3 Power Consumptions

Parameter	Test Conditions (VCC=3.3V, 25°C)	Current	Unit
TX	Transmit max. Boost mode enabled	45	mA
TX	Transmit max. Boost mode disabled	33	mA
TX	Transmit min. Boost mode disabled	23	mA
TX	Transmit max, file transfer @115.2kbps	45	mA
RX	Receive, Boost mode enabled	31	mA
RX	Receive, Boost mode disabled	28	mA
Idle	Not connect, Receiver off	9	mA
Sleep	Interval(Sleep=1000ms, Wake-up=5ms)	2	µA
Power-down	Shutdown-mode	1	µA
Reset	Quiescent, nReset asserted	2	µA

2.4 Digital I/O Specifications

Table 2-4 Digital I/O Specifications

Parameter (VCC= 3.3V, 25°C)	Min	Typ.	Max	Unit
Input voltage for logic 0	0		0.66	V
Input voltage for logic 1	2.64		3.3	V
Input current for logic 0			-0.5	μA
Input current for logic 1			0.8	μA
Input pull-up resistor value		30		kΩ
Input pull-down resistor value		30		kΩ
Output voltage for logic 0	0		0.6	V
Output voltage for logic 1	2.7		3.3	V
Output source current, GPIO[0, 1, 3~9, 12~16]			4	mA
Output source current, GPIO[2, 10, 11, 16]			8	mA
Output sink current, GPIO[0, 1, 3~9, 12~16]			4	mA
Output sink current, GPIO[2, 10, 11, 16]			8	mA

2.5 ADC Specifications

Table 2-5 ADC Specifications

Parameter (VCC= 3.3V, 25°C)	Min	Typ.	Max	Unit
VREF	1.19	1.2	1.21	V
VREF output current			1	mA
VREF load capacitance			10	nF
Minimum input voltage	0			V
Maximum input voltage			VREF	V
Single-ended signal range			VREF	V
Differential signal range	-VREF		+VREF	
Common mode range	0		VREF	
Input referred ADC offset	-10		10	mV
Input Impedance	When taking a Sample	1		MΩ
	When not taking a Sample	10		

3 RF Characteristics

3.1 Transmitter Characteristics

Table 3-1 Transmitter Characteristics (VCC = 3.3V, 25°C)

Parameter	Test Conditions	Min	Typ.	Max	Unit
Frequency range*		2405		2480	MHz
Maximum output power	Boost mode enabled		8		dBm
Minimum output power	Boost mode disabled		-50		dBm
Error vector magnitude			5	15	%
Carrier frequency error		-40		+40	ppm

* Frequency range: Channel number 16ch (0x0b, 0x0c, 0x0d 0x18, 0x19, 0x1a)

3.2 Receive Characteristics

Table 3-2 Receive Characteristics (VCC = 3.3V, 25°C)

Parameter	Test Conditions	Min	Typ.	Max	Unit
Frequency range		2405		2480	MHz
Sensitivity	1% PER, 20byte packet defined by IEEE 802.15.4		-100		dBm
ACR - High-side	IEEE 802.15.4 signal at -82dBm		35		dB
ACR - Low-side		-	35		dB
ACR - 2 nd High-side		-	46		dB
ACR - 2 nd Low-side		-	46		dB
Channel rejection for all other channels		-	39		dB
802.11g rejection centered at +12Mhz or -13MHz		-	36		dB
Maximum input signal level for correct Operation (low gain)		0			dBm
Image suppression		-	30		dB
Relative frequency error(2x40ppm required by IEEE 802.15.4)	IEEE 802.15.4 signal at -82dBm	-120		+120	ppm
Relative timing error (2x40ppm required by IEEE 802.15.4)		-120		+120	ppm
Linear RSSI range		40			dB
RSSI Range		-90		-40	dB

4 Device Terminal Descriptions

4.1 UART Mode

The SC1 UART controller is enabled with SC1_MODE set to 1.

The UART mode contains the features as shown in the Table 4-1.

Table 4-1 Possible UART Settings

Parameter		Possible Values
Baud Rate	Minimum	300 baud (0%Error)
	Maximum	921.6 kbaud (0.16%Error)
Flow Control		RTS/CTS(optional) or None
Parity		None, Odd, or Even
Number of Stop Bits		1 or 2
Bits per Channel		7 or 8

The SC1 UART module obtains its reference baud-rate clock from a programmable baud generator. Baud rates are set by a clock division ratio from the 24MHz clock.

Table 4-2 UART Baud Rates

Baud rate (bps)	SC1_UARTPER	SC1_UARTFRAC	Baud Rate Error (%)
300	40000	0	0
4800	2500	0	0
9600	1250	0	0
19200	625	0	0
38400	312	1	0
57600	208	1	-0.08
115200	104	0	+0.16
460800	26	0	+0.16
921600	13	0	+0.16

4.2 Reset

A single active low pin, /RESET (22), is provided reset the system. This pin has a Schmitt triggered input. When /RESET asserts, all ZE20S registers return to their reset state as defined. In addition, the ZE20S consumes 1.5mA (typical) of current when held in RESET.

4.3 GPIO

The ZE20S has 17 multi-purpose GPIO pins that can be configured in a variety of ways. All pins have the following programmable features:

- Selectable input, output, or bi-directional.
- Can have internal pull-up or pull-down.

Four GPIO pins (GPIO 2, 10, 11, 16) can sink and source higher current than standard GPIO outputs.

4.4 JTAG

The ZE20S includes a standard Serial Wire and JTAG (SWJ) Interface. The SWJ is the primary debug and programming interface of the EM357. The SWJ gives debug tools access to the internal buses of the EM357, and allows for non-intrusive memory and register access as well as CPU halt-step style debugging. Therefore, and design implementing the EM357 should make the SWJ signals readily available.

JTAG pins:

- JTCK (15)
- JTDO (16)
- JTDI (17)
- JTMS (18)
- JREST (19)

5 Application Schematics

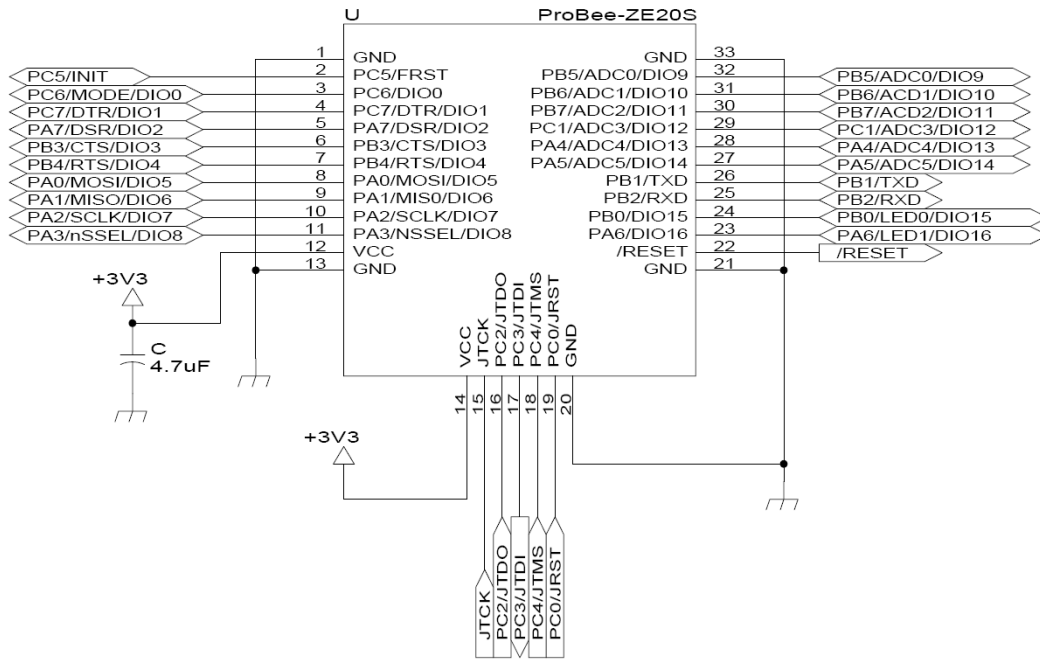

Figure 5-1 ZE20S Interface Connector

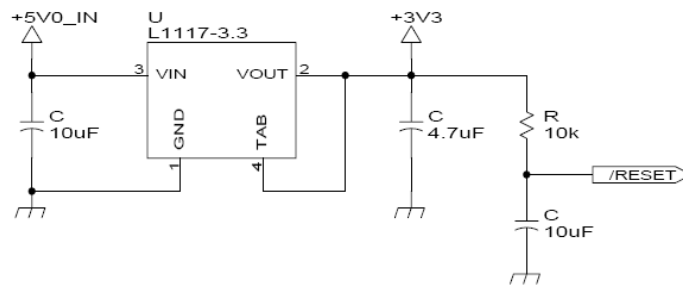

Figure 5-2 Power and POR

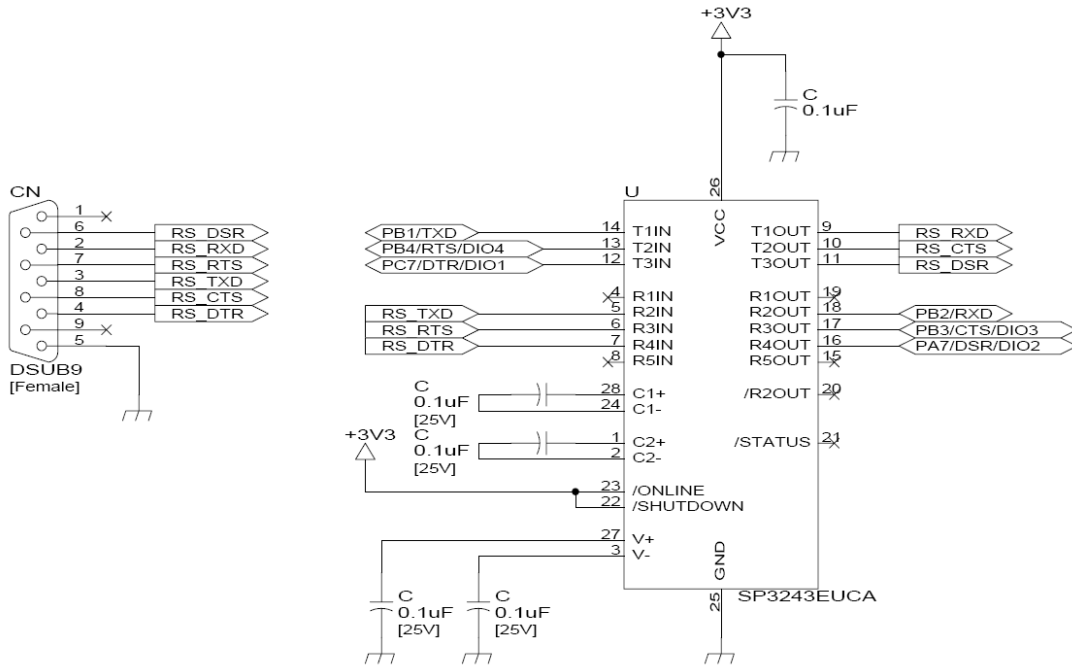

Figure 5-3 RS232 Serial

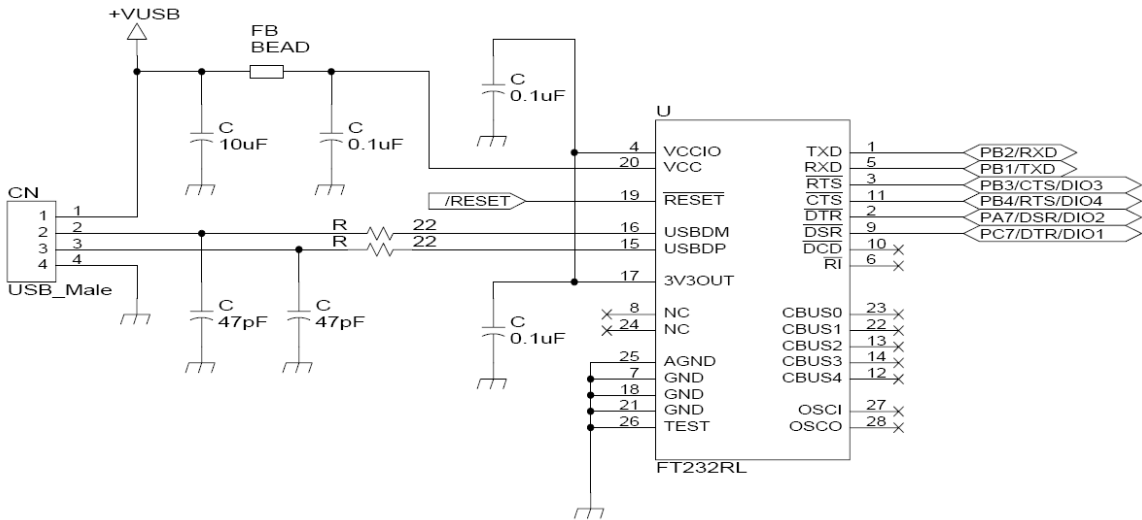

Figure 5-4 USB to UART

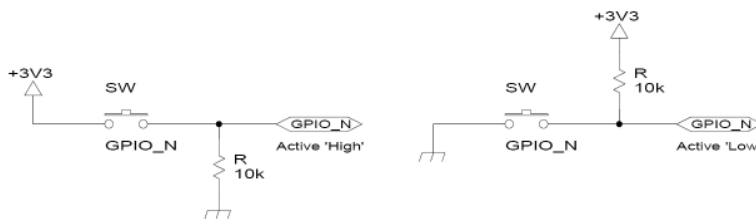

Figure 5-5 GPIO Button Input

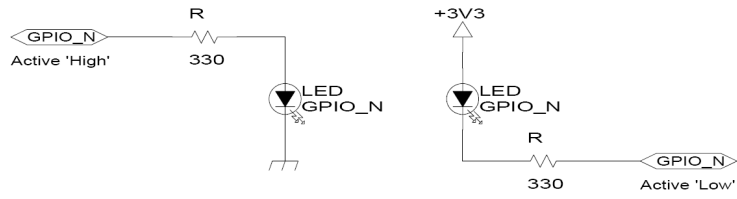

Figure 5-6 GPIO LED Output

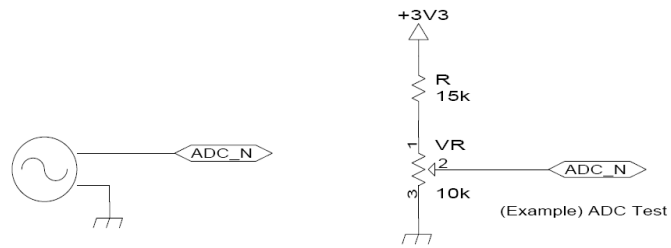

Figure 5-7 ADC VR Input

6 Contact Information

Website

<http://www.sena.com>

Email

Sales: sales@sena.com

Technical Support: support@sena.com

U.S. / Canada / South America

3150 Almaden Expressway, Suite 233

San Jose, CA 95118, United States

Toll Free (US/Canada): 8668-US-SENA (866-887-7362)

Main: 408-448-1997

Fax: 408-907-3738

EU / Africa

12-14 Rond Point des Champs Elysées

75008 Paris, France

Tel: +33 (0)1 53 53 16 29

Fax: +33 (0)1 70 24 70 90

Asia / Pacific

210 Yangjae-dong, Seocho-gu

Seoul 137-130, Korea (Republic of)

Main: +82-2-571-8283

Sales direct: +82-2-529-7024

Support direct: +82-2-573-5422

Fax: +82-2-573-7710