



KBPC/BR15/25/35/50 SERIES

**SINGLE PHASE 15/25/35/50 AMPS.
SILICON BRIDGE RECTIFIERS**

**Voltage Range
50 to 1000 Volts
Current
15/25/35/50 Amperes**

FEATURES

- *UL Recognized File # 230084
- *Surge overload 200-400 Amperes peak
- *Low forward voltage drop
- *Mounting Position: Any
- *Electrically isolated base-1800 Volts
- *Solderable 0.25" FASTON terminals
- *Materials used carries U/L recognition

TERMINALS/ METAL

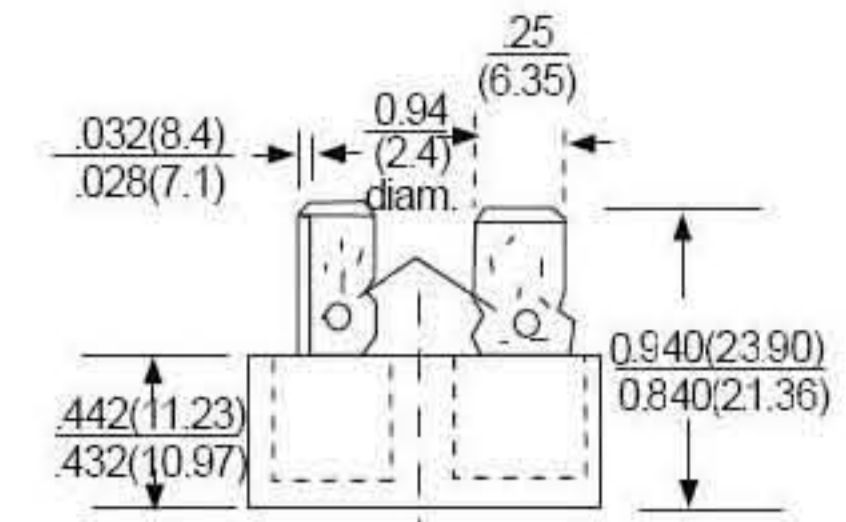
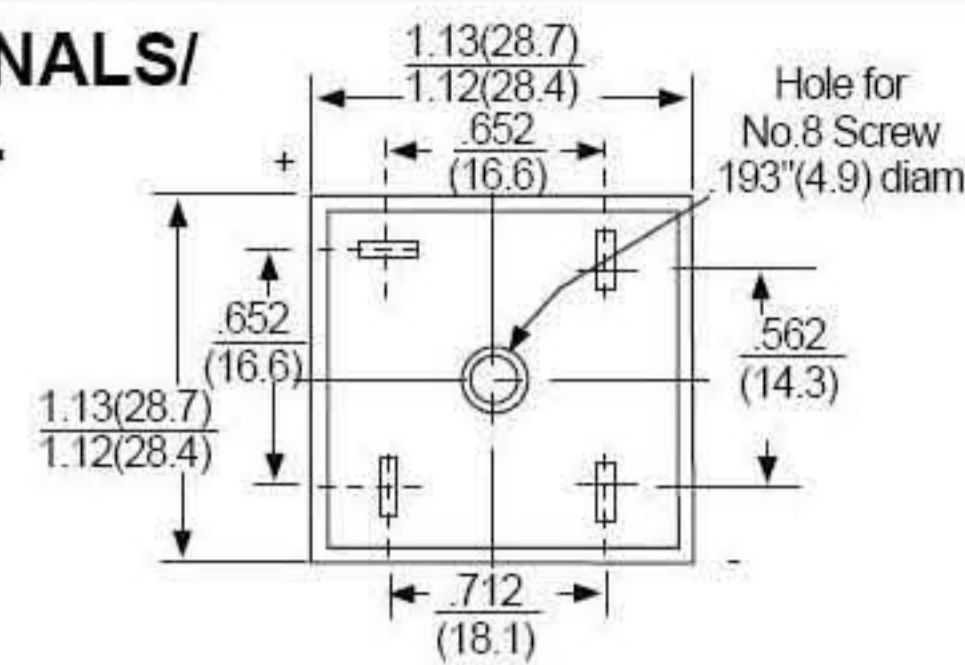

LEAD / METAL

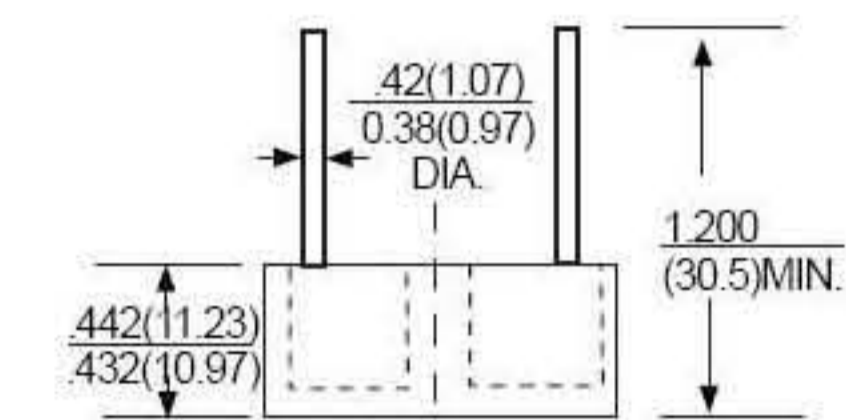
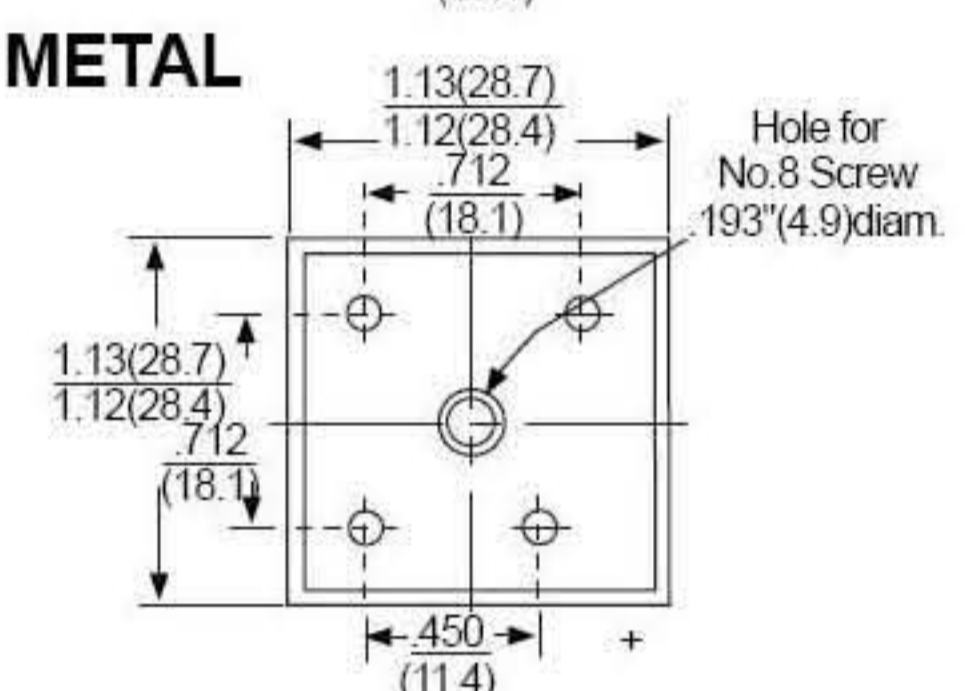

KBPC

TERMINALS/ PLASTIC

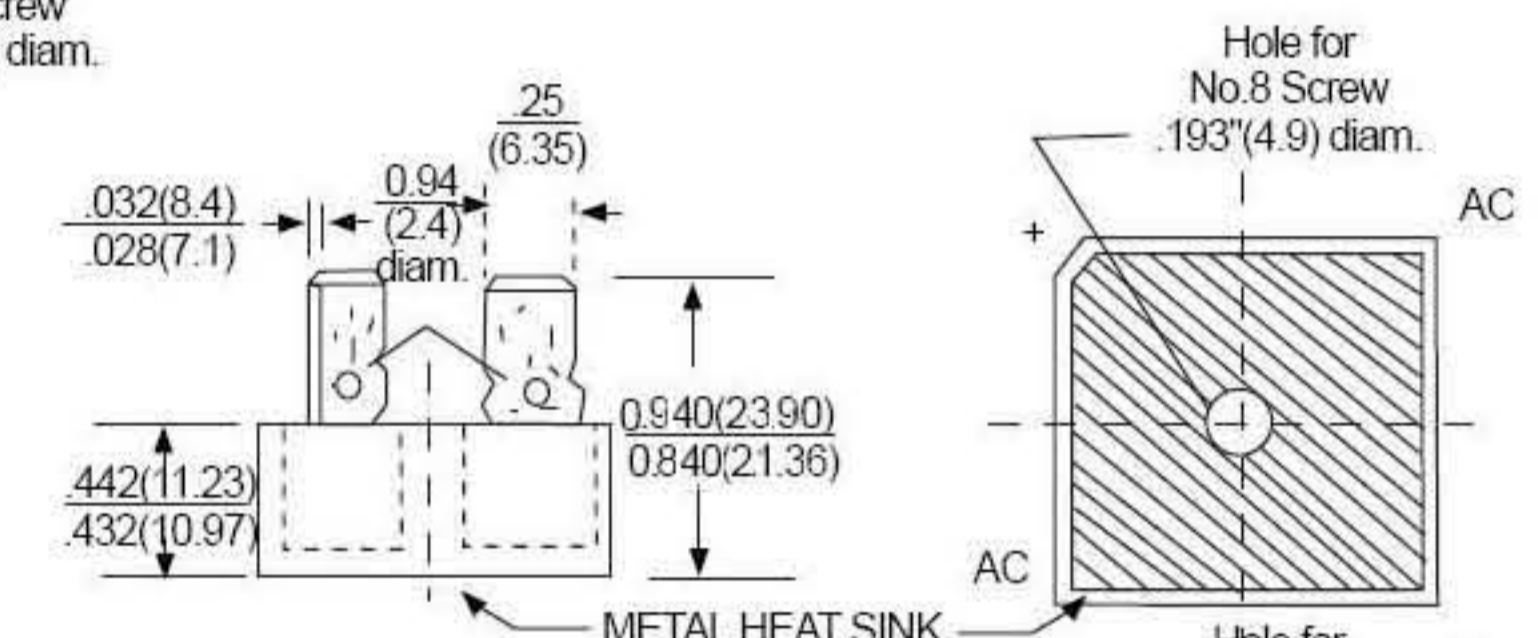
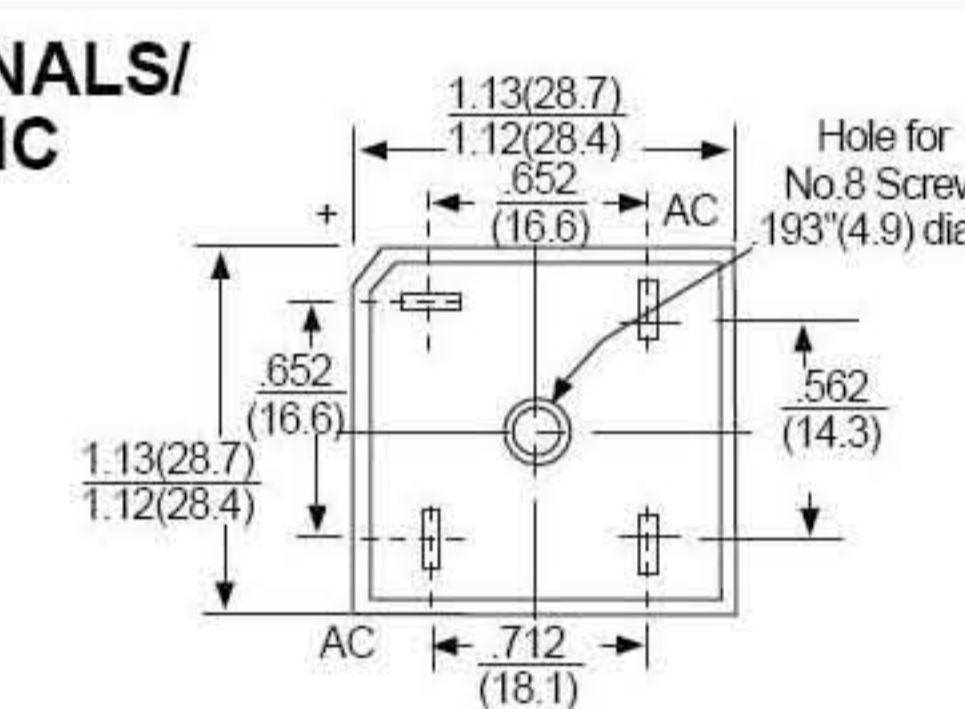

LEAD / PLASTIC

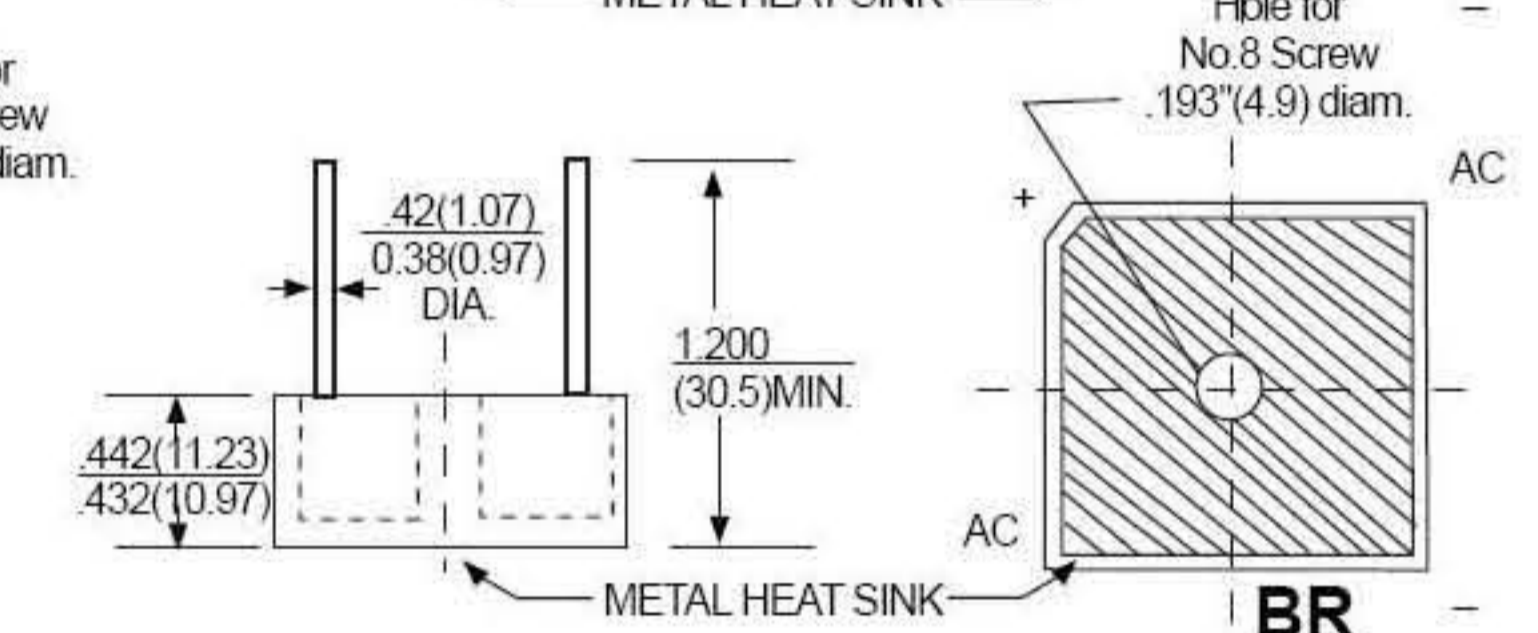
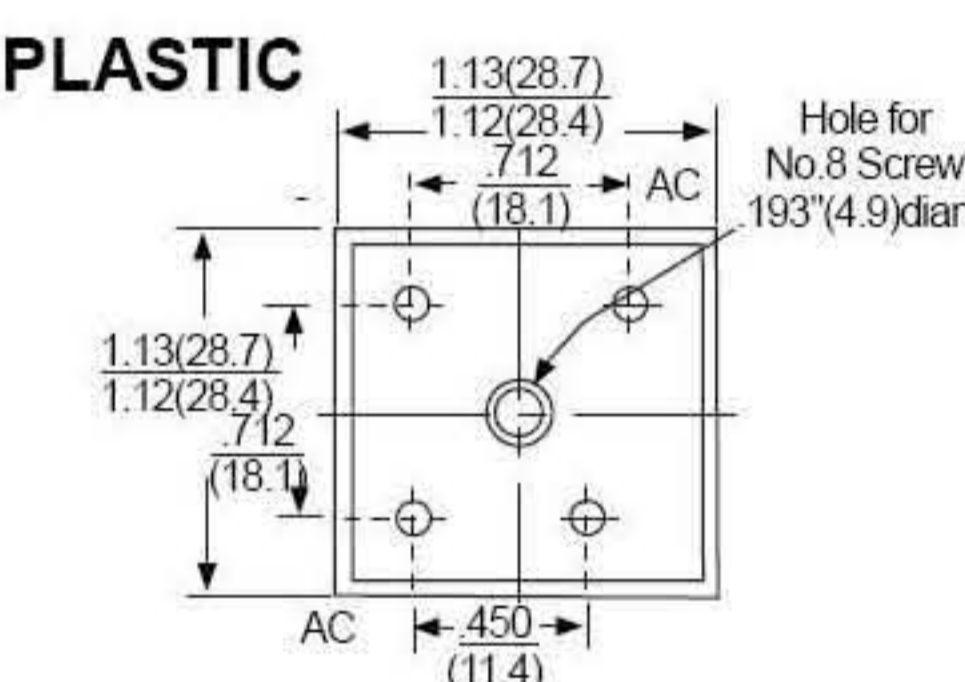

BR

MAXIMUM RATINGS AND ELECTRICAL CHARACTERISTICS

Rating at 25°C ambient temperature unless otherwise specified.
Resistive or inductive load 50Hz.
For capacitive load current by 20%

Type Number		KBPC BR	KBPC BR	KBPC BR	KBPC BR	KBPC BR	KBPC BR	KBPC BR	UNITS	
		15005	1501	1502	1504	1506	1508	1510		
		25005	2501	2502	2504	2506	2508	2510		
		35005	3501	3502	3504	3506	3508	3510		
		50005	5001	5002	5004	5006	5008	5010		
Maximum Repetitive Peak Reverse Voltage	VRRM	50	100	200	400	600	800	1000	V	
Maximum RMS Bridge Input Voltage	VRMS	35	70	140	280	420	560	700	V	
Maximum Average Forward Rectified Output Current @Tc = 55°C	IF(AV)	KBPC BR 15	15	KBPC BR 25	25	KBPC BR 35	35	KBPC BR 50	50	A
Peak Forward Surge Current 8.3ms single half sine-wave super imposed on rated load	IFSM	KBPC BR 15	300	KBPC BR 25	400	KBPC BR 35	400	KBPC BR 50	500	A
Maximum Forward Voltage Drop per Leg at 7.5/12.5/17.5/25.0A Peak	VF	1.1							V	
Maximum Reverse Current at Rate DC Blocking Voltage per element @TA = 25°C	IR	5							uA	
Operating Temperature Range Tc	TJ	-55 to +125							°C	
Storage Temperature Range TA	TSTG	-55 to +150							°C	

NOTES: 1. Also available on KBPC 15W/25W/35W/50W series.

RATING AND CHARACTERISTIC CURVES KBPC/BR 15/25/35/50 SERIES



FIG.1 -MAXIMUM FORWARD SURGE CURRENT

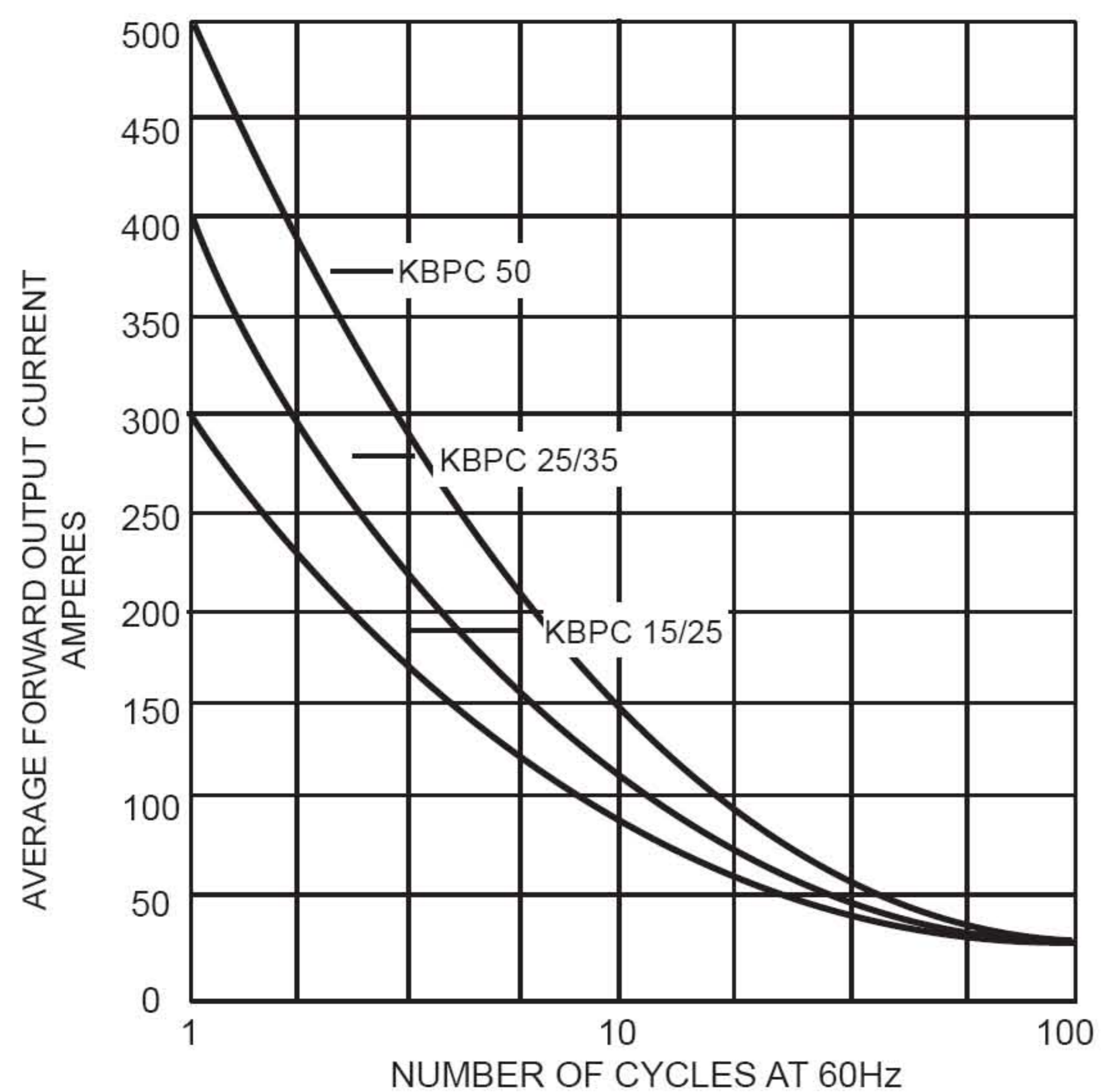

FIG.2 -DERATING CURVE
OUTPUT RECTIFIED CURRENT

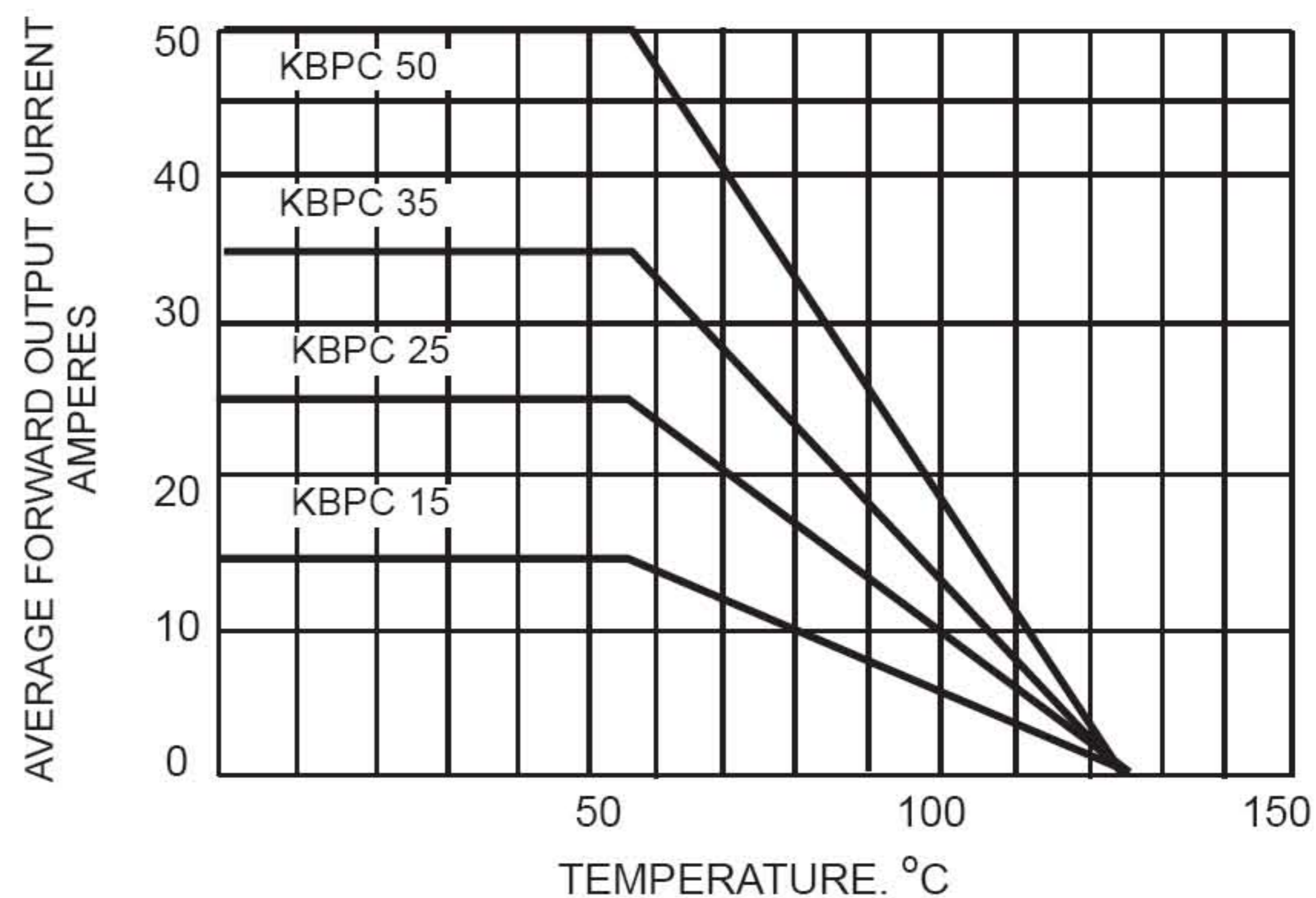

FIG.3-TYPICAL FORWARD
CHARACTERISTICS

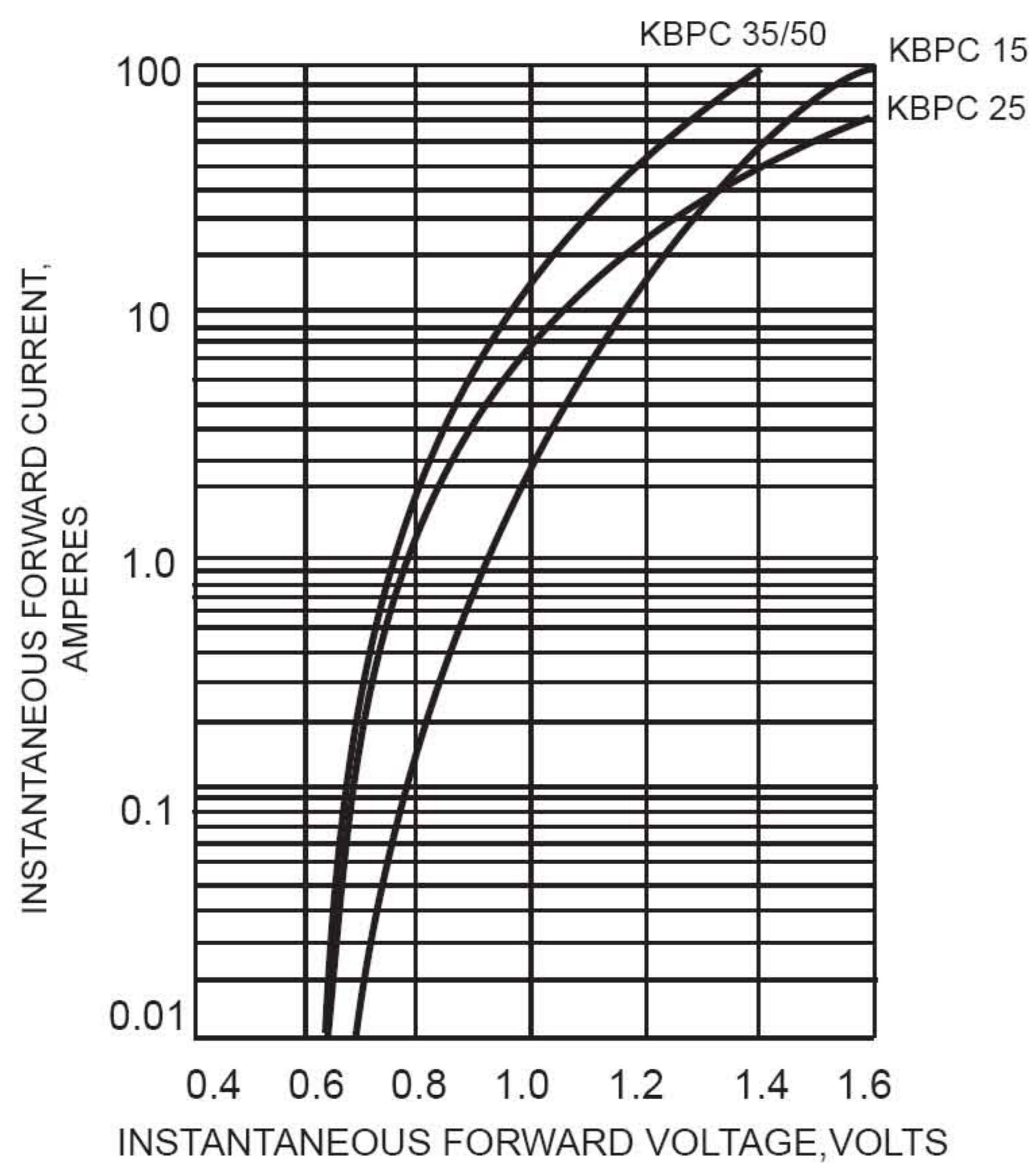

FIG.4 - TYPICAL REVERSE
CHARACTERISTICS

