

FOR 2 Circuits

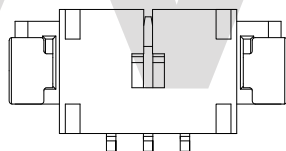

FOR 3 Circuits

A = 1.25 x No. of Spaces
 B = A + 6.1
 C = A + 1.9

* Available in 2 through 15 circuits

ORDERING CODE:

CI44 ** M 1 H 00
 ① ② ③ ④ ⑤ ⑥

- ① SERIES NO.:
- ② NO. OF CIRCUITS: 02 TO 15
- ③ CONTACTS TYPE: M= SMT
- ④ PLATING OPTION:
 1= TIN OVER NICKEL PLATED
- ⑤ TAIL STYLE: H= RIGHT ANGLE
- ⑥ OPTION: 00= STANDARD(TUBE PACKING)
 R0= TAPE & REEL PACKING

△ Note:

- * Material :
 Insulation:
 Nylon 46+40% G.F UL 94V-0
 Color Nature(Ivory)
 Contact : Phosphor Bronze
 Fixed Tab : Brass with Tin Plated
- * Recommended mating part:
 Housing : CI44**S0000
 Terminal : CI44T011PPO

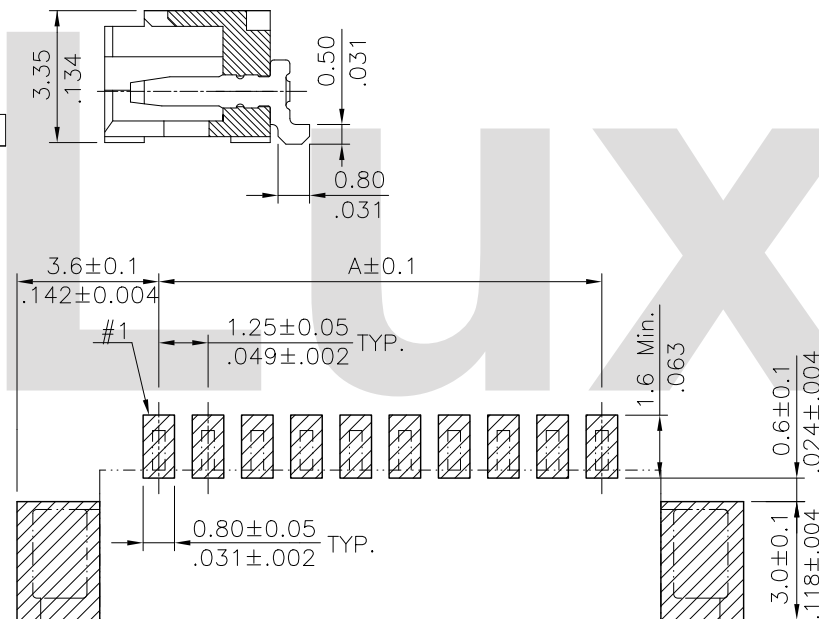

Sold Pad Pattern

Tin-Lead Process

RoHS Compliant

⑧	Sun	5/26-11'	ECN11071/ECR11010-1			DATE	UNIT: mm / inch	TITLE: 1.25MM(.049")	 瀚荃股份有限公司 CviLux Corporation
⑦	Sandy	6/18-08'	ECN08287		DRAWN BY: Sun	6/21-11'	TOLERANCE UNLESS OTHERWISE SPECIFIED	RIGHT ANGLE SMT TYPE HEADER	
⑥	Sandy	04/29-07'	ECN07153		ENGINEER: Clark	7/06-11'	.X ± 0.25/.010 X' ± 1"	MATERIAL:	
⑤	Eager	02/13-07'	ECR07015-0/ECN07050		CHECKED BY: Eisley	7/07-11'	.XX ± 0.15/.006 X' ±	FINISH:	
SYM	NAME	DATE	REVISIONS	APPROVED BY: Eisley	7/07-11'	.XXX ± 0.08/.003 XX' ±			DRAWING NO. CI4405SO SCALE 5 / 1 PART NO. CI44**M1H*0 SHEET 1 OF 2

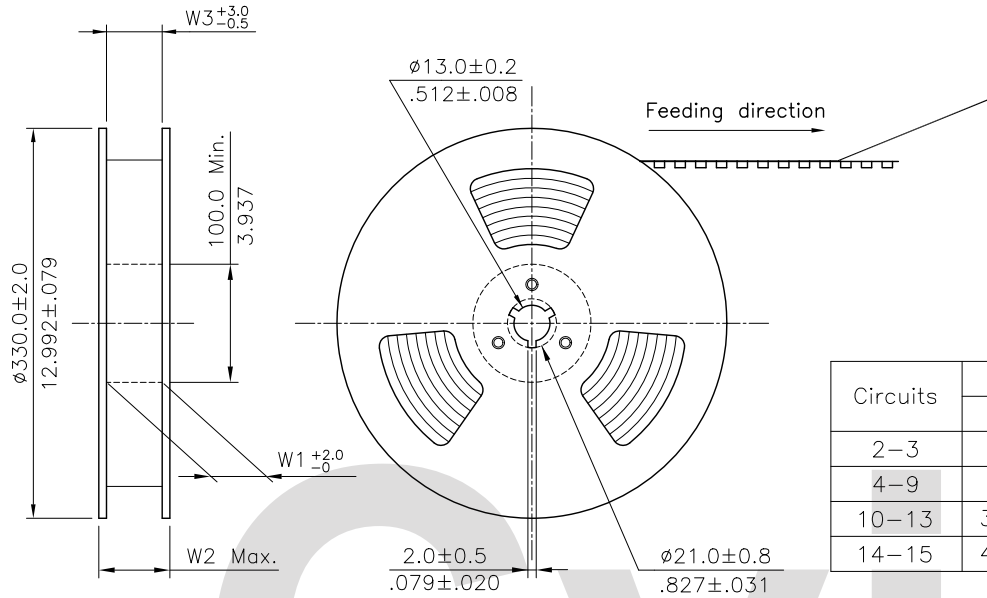

NOTE :

- * Reel Material : Corrugated Paper
- * Carrier Material : Clear, Conductive Polystyrene Alloy
- * Cover Tape Material : Polyester
- * Cover Tape Peel Strength : 0.1N – 1.3N
- * Carrier camber is within 1mm in 100mm
- * All dimensions meet EIA-481-2 & EIA-481-3 requirements.
- * Quantity : 1400 PCS/Reel

Circuits	Dimension					Packing (Reel/Caton)
	E	F	W1	W2	W3	
2-3	16.0(.630)	---	16.5(.650)	22.5(.886)	16.5(.650)	11
4-9	24.0(.945)	---	24.5(.965)	30.5(1.201)	24.5(.965)	9
10-13	32.0(1.260)	28.40(1.118)	32.5(1.280)	38.5(1.516)	32.5(1.280)	7
14-15	44.0(1.732)	40.40(1.591)	44.5(1.752)	50.5(1.988)	44.5(1.752)	5

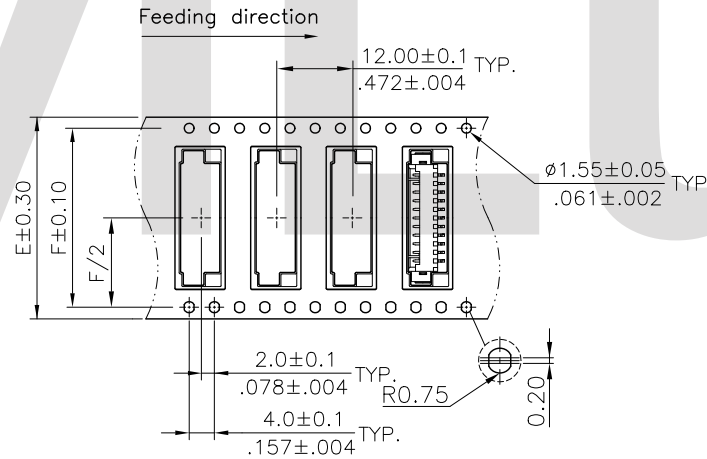
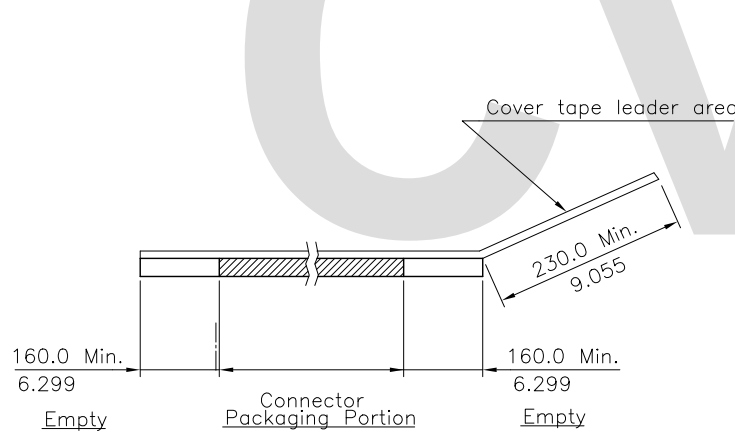

WIDTH : 32.44 mm Carrier

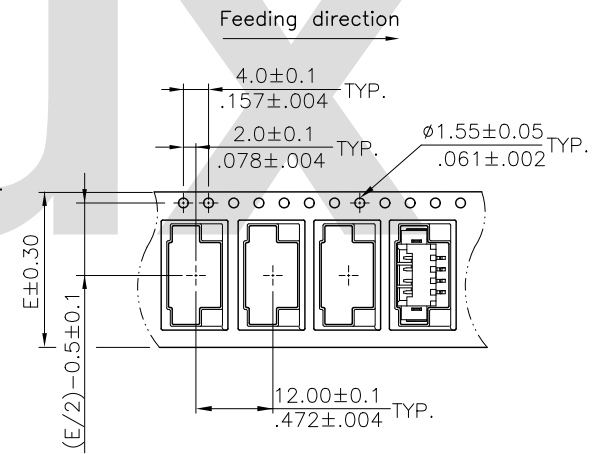

WIDTH : 16.24 mm Carrier

RoHS Compliant

8	Sun	5/26-11'	ECN11071/ECR11010-1		DATE	UNIT: mm / inch	TITLE: 1.25MM(.049")	 瀚荃股份有限公司 CviLux Corporation	
7	Sandy	6/18-08'	ECN08287		DRAWN BY: Sun	6/21-11'	TOLERANCE UNLESS OTHERWISE SPECIFIED		RIGHT ANGLE SMT TYPE HEADER
6	Sandy	04/29-07'	ECN07153		ENGINEER: Clark	7/06-11'	.X ±		MATERIAL:
5	Eager	02/13-07'	ECR07015-0/ECN07050		CHECKED BY: Eisley	7/07-11'	.XX ±		FINISH:
SYM	NAME	DATE	REVISIONS		APPROVED BY: Eisley	7/07-11'	.XXX ±		
DRAWING NO.		CI4405SO		PART NO.		CI44**M1H*0			
SCALE		SHEET 2 OF 2							