

STM32-P107 development board

User's Manual



All boards produced by Olimex are ROHS compliant

Rev. F, August 2012

Copyright(c) 2012, OLIMEX Ltd, All rights reserved

INTRODUCTION

STM32-P107 prototype board provides easy way for developing and prototyping with the new STM32F107VCT6 connectivity line microcontroller, produced by STMicroelectronics. STM32-P107 has JTAG port for programming and debugging, USB_OTG, user button, two status leds, and most of the GPIOs are on extension headers where you can connect your additional circuits.

BOARD FEATURES

- CPU: STM32F107VCT6 32 bit ARM-based microcontroller with 256 KB Flash, 64 KB RAM, USB OTG, Ethernet, 10 timers, 2 CANs, 2 ADCs, 14 communication interfaces
- JTAG connector with ARM 2x10 pin layout for programming/debugging
- USB_OTG
- USB_HOST
- 100Mbit Ethernet
- RS232
- Mini SD/MMC card connector
- UEXT connector
- Power Jack
- Two user buttons
- RESET button and circuit
- Two status leds
- Power-on led
- 3V battery connector
- Extension port connectors for many of microcontrollers pins
- PCB: FR-4, 1.5 mm (0,062"), soldermask, silkscreen component print
- Dimensions: 132.08x96.52mm (5.2x3.8")

ELECTROSTATIC WARNING

The STM32-P107 board is shipped in protective anti-static packaging. The board must not be subject to high electrostatic potentials. General practice for working with static sensitive devices should be applied when working with this board.

BOARD USE REQUIREMENTS

Cables: The cable you will need depends on the programmer/debugger you use. If you use [ARM-JTAG](#), you will need LPT cable, if you use [ARM-JTAG-EW](#), [ARM-USB-OCD](#), [ARM-USB-OCD-H](#), [ARM-USB-TINY](#), or [ARM-USB-TINY-H](#) you will need 1.8 meter USB A-B cable, for ARM-USB-OCD and ARM-USB-OCD-H you will need RS232 cable, too.

Hardware: Programmer/Debugger – one of the Olimex ARM Programmers: ARM-JTAG, ARM-JTAG-EW, ARM-USB-OCD, ARM-USB-OCD-H, ARM-USB-OCD-TINY, ARM-USB-OCD-H.

Software: ARM C compiler

PROCESSOR FEATURES

STM32-P107 board use ARM-based 32-bit microcontroller **STM32F107VCT6** with these features:

- Core: ARM 32-bit Cortex™-M3 CPU
 - 72 MHz maximum frequency, 1.25 DMIPS/MHz (Dhrystone 2.1) performance at 0 wait state memory access
 - Single-cycle multiplication and hardware division
- Memories
 - 256 Kbytes of Flash memory
 - 64 Kbytes of SRAM
- Clock, reset and supply management
 - 2.0 to 3.6 V application supply and I/Os
 - POR, PDR, and programmable voltage detector (PVD)
 - 25 MHz crystal oscillator
 - Internal 8 MHz factory-trimmed RC
 - Internal 40 kHz RC with calibration
 - 32 kHz oscillator for RTC with calibration
- Low power
 - Sleep, Stop and Standby modes
 - VBAT supply for RTC and backup registers
- 2 × 12-bit, 1 μs A/D converters (16 channels)
 - Conversion range: 0 to 3.6 V
 - Sample and hold capability
 - Temperature sensor
 - up to 2 MSps in interleaved mode
- 2 × 12-bit D/A converters
- DMA: 12-channel DMA controller

- Supported peripherals: timers, ADCs, DAC, I²Ss, SPIs, I²Cs and USARTs
- Debug mode
 - Serial wire debug (SWD) & JTAG interfaces
 - Cortex-M3 Embedded Trace Macrocell™
- 80 fast I/O ports
 - 80 I/Os, all mappable on 16 external interrupt vectors and almost all 5 V-tolerant
- 10 timers
 - four 16-bit timers, each with up to 4 IC/OC/PWM or pulse counter and quadrature (incremental) encoder input
 - 1 × 16-bit motor control PWM timer with dead-time generation and emergency stop
 - 2 × watchdog timers (Independent and Window)
 - SysTick timer: a 24-bit downcounter
 - 2 × 16-bit basic timers to drive the DAC
- 14 communication interfaces
 - 2 × I²C interfaces (SMBus/PMBus)
 - 5 USARTs (ISO 7816 interface, LIN, IrDA capability, modem control)
 - 3 SPIs (18 Mbit/s), 2 with a multiplexed I²S interface that offers audio class accuracy via advanced PLL schemes
 - 2 × CAN interfaces (2.0B Active) with 512 bytes of dedicated SRAM
 - USB 2.0 full-speed device/host/OTG controller with on-chip PHY that supports HNP/SRP/ID with 1.25 Kbytes of dedicated SRAM
 - 10/100 Ethernet MAC with dedicated DMA and SRAM (4 Kbytes): IEEE1588 hardware support, MII/RMII available on all packages
- CRC calculation unit, 96-bit unique ID

BLOCK DIAGRAM

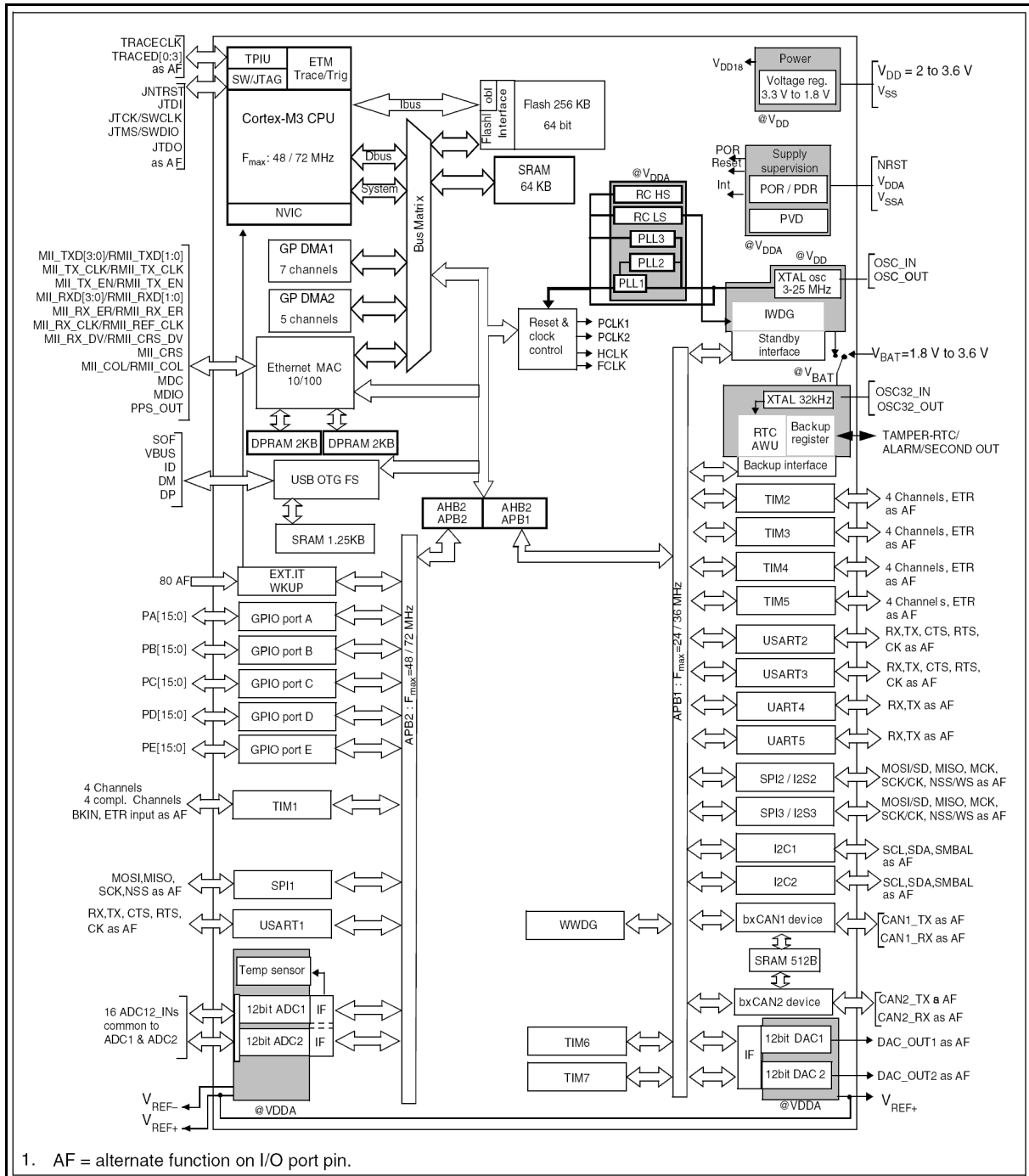

MEMORY MAP

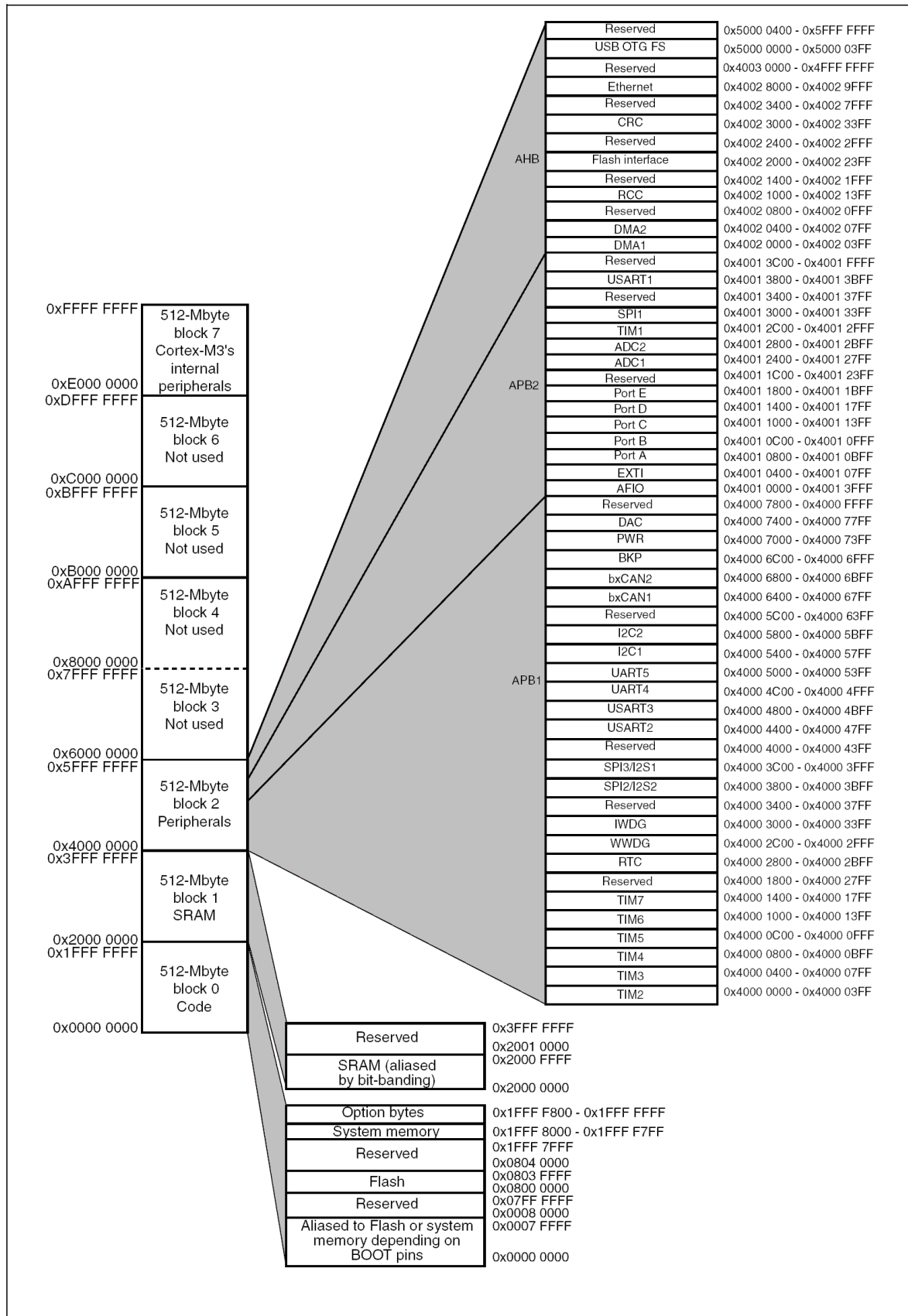

SCHEMATIC

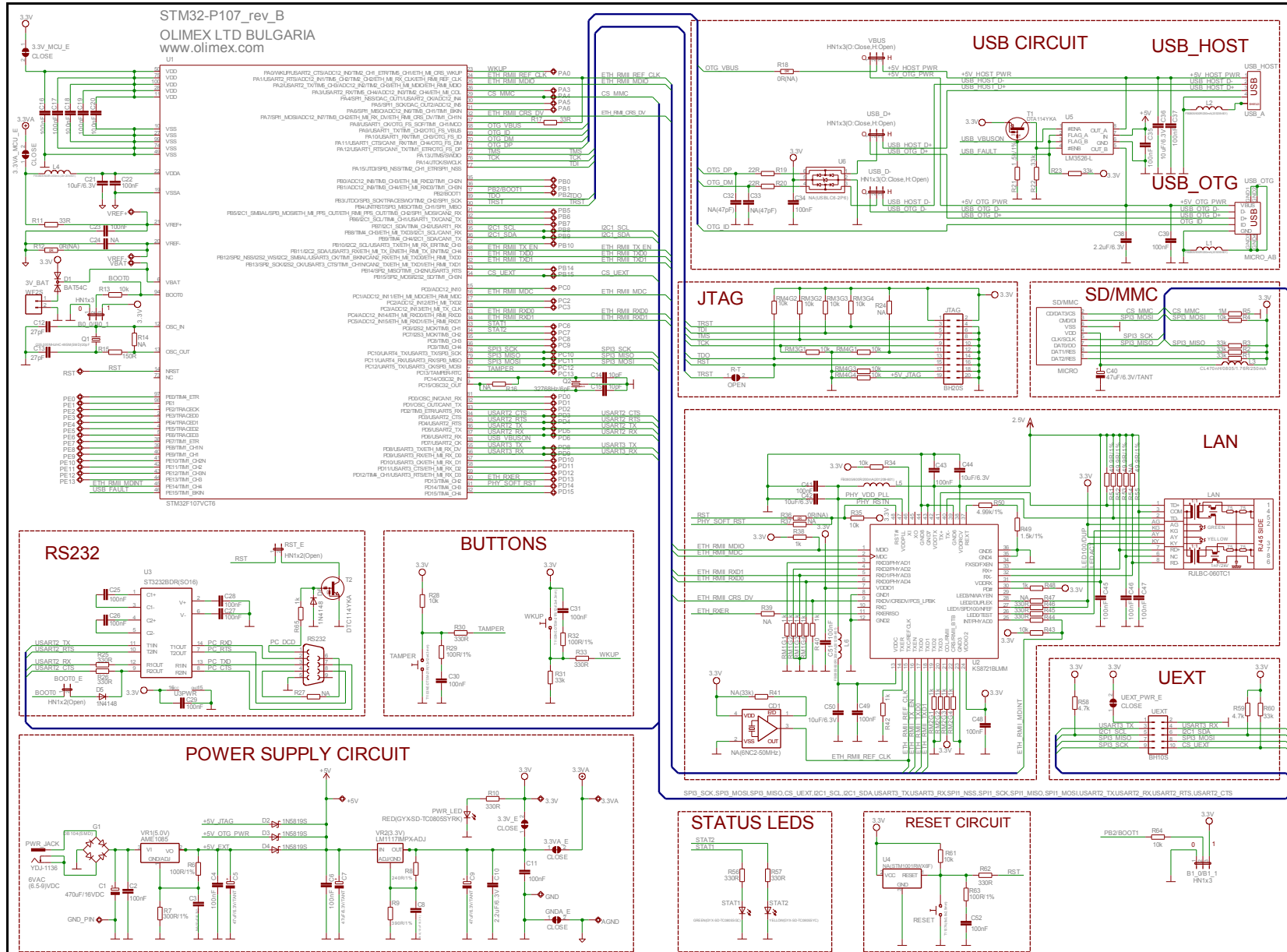

BOARD LAYOUT

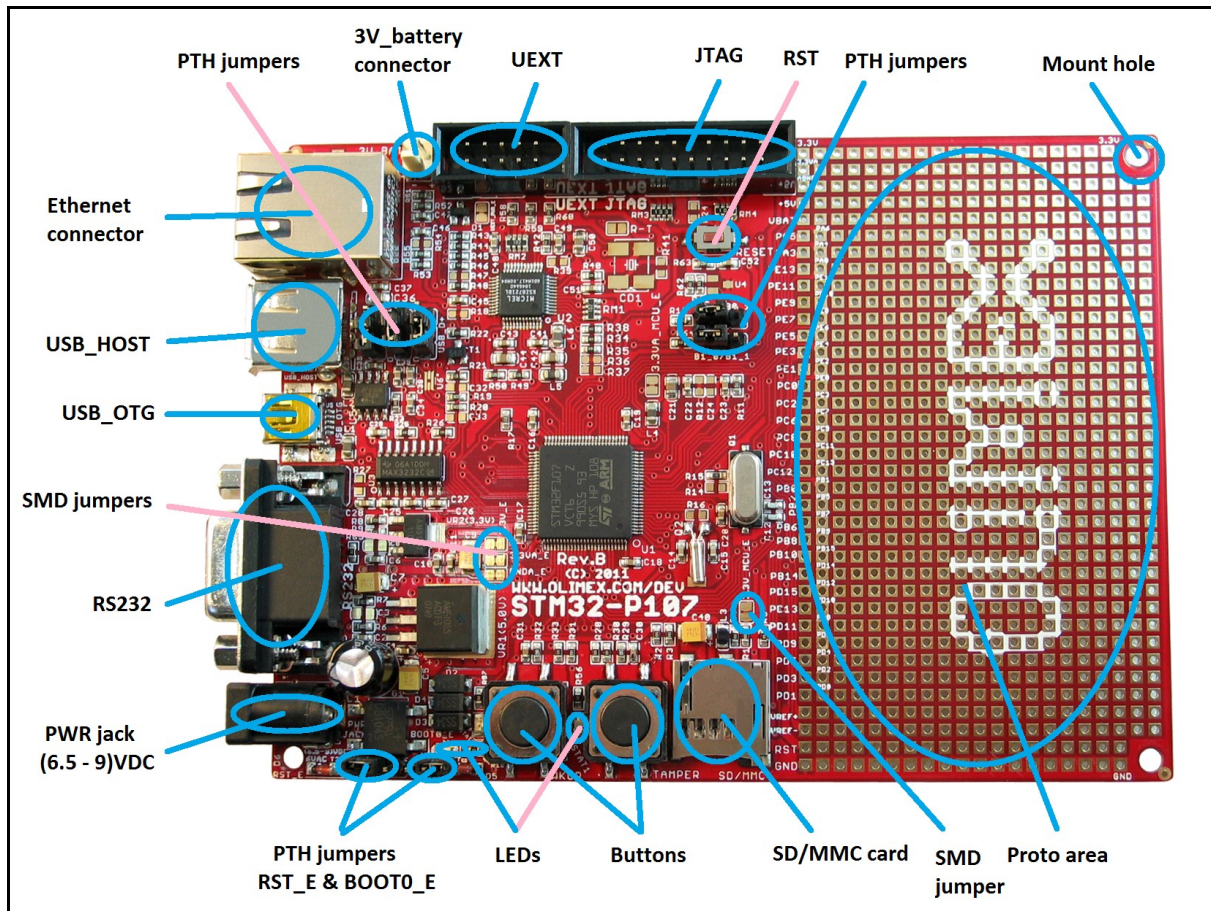

POWER SUPPLY CIRCUIT

STM32-P107 can take power from three sources:

- PWR connector where (6.5-9)V DC or 6V AC is applied by external power source.
- +5V_OTG-PWR from USB OTG
- +5V_JTAG from JTAG

The programmed board power consumption is about 70 mA.

RESET CIRCUIT

STM32-P107 reset circuit includes JTAG connector pin 15, U2 (STE101P) pin 28 (RESET), R73(10k), R74(330Ohm), R75(100Ohm/1%), C55(100nF), STM32F107 pin 14 (NRST) and RESET button.

CLOCK CIRCUIT

Quartz crystal 25 MHz is connected to **STM32F107** pin 12 (OSC_IN) and pin 13 (OSC_OUT).

Quartz crystal 32.768kHz is connected to **STM32F107** pin 8 (PC14/OSC32_IN) and pin 9 (PC15/OSC32_OUT).

JUMPER DESCRIPTION

PWR_SEL



5-6

When position 1-2 is shorted – the board is power supplied from JTAG.



3-4

When position 3-4 is shorted – the board is power supplied from USB_OTG.



1-2

When position 5-6 is shorted – the board is power supplied from External power source.

Default state is – position 5-6 – shorted.

B0_0/B0_1



When this jumper is in position B0_1 – BOOT0 is connected to 3.3V, and when the jumper is in position B0_0 – BOOT0 is connected to GND.

Default state is B0_0.

B1_0/B1_1



When this jumper is in position B1_1 – BOOT1 is connected to 3.3V, and when the jumper is in position B1_0 – BOOT1 is connected to GND.

Default state is B1_0.

VBUS



O H

When is in position “H” - connects +5V_HOST_PWR to OTG_VBUS.

When is in position “O” - connects +5V_OTG_PWR to OTG_VBUS.

Default state is “O”.

USB_D+



O H

When is in position “H” - connects USB_HOST_D+ to OTG_DP.

When is in position “O” - connects USB_OTG_D+ to OTG_DP.

Default state is “O”.

USB_D-



O H

When is in position “H” - connects USD_HOST_D- to OTG_DM.

When is in position “O” - connects USB_OTG_D- to OTG_DM.

Default state is “O”.

PWDW_D



When is closed – disables Ethernet transceiver (STE101P) Power Down Mode. STE101P is active.

Default state is closed.

3.3V_MCU_E



Enable microcontroller 3.3V power supply

Default state is closed.

3.3V_E



Enable regulator VR2 (3.3V) - LM1117

Default state is closed.

3.3VA_E



Enables board 3.3V analog power supply.

Default state is closed.

3.3VA_MCU_E



Enables microcontroller 3.3V analog power supply.

Default state is closed.

GNDA_E



Enables board analog GND.

Default state is closed.

R-T



Connects RST to TRST

Default state is open.

RST_E, BOOT_E jumpers



Note that it is recommended to move those jumpers together – either both should be open or both should be closed.

When both are closed RS232 boot is enabled.

Default states are RST_E – open; BOOT_E – open.

INPUT/OUTPUT

Status LED1 (green) with name **STAT1** connected to STM32F107 pin 63 (PC6/I2S2_MCK/TIM3_CH1).

Status LED2 (yellow) with name **STAT2** connected to STM32F107 pin 64 (PC7/I2S3_MCK/TIM3_CH2).

Power-on LED (red) with name **PWR** – this led shows that +3.3V is applied to the board.

User button with name **WKUP** connected to STM32F107 pin 23 (PA0/WKUP).

User button with name **TAMPER** connected to STM32F107 pin 7 (PC13/TAMPER-RTC).

Reset button with name **RESET** connected to STM32F107 pin 14 (NRST).

CONNECTOR DESCRIPTIONS

JTAG

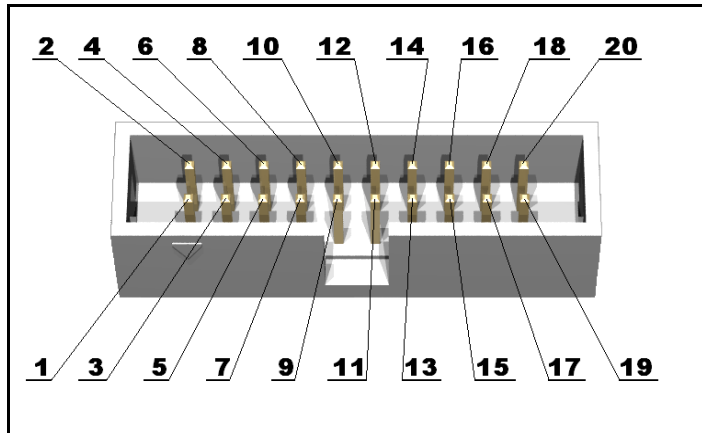

The JTAG connector allows the software debugger to talk via a JTAG (Joint Test Action Group) port directly to the core. Instructions may be inserted and executed by the core thus allowing STM32F107 memory to be programmed with code and executed step by step by the host software.

For more details refer to IEEE Standard 1149.1 - 1990 Standard Test Access Port and Boundary Scan Architecture and STM32F107 datasheets and users manual.

Pin #	Signal Name	Pin #	Signal Name
1	3.3V	2	3.3V
3	TRST	4	GND
5	TDI	6	GND
7	TMS	8	GND
9	TCK	10	GND
11	PULL-DOWN	12	GND
13	TDO	14	GND
15	RST	16	GND
17	PULL-DOWN	18	GND
19	+5V_JTAG	20	GND

PWR JACK

Pin #	Signal Name
1	Power Input
2	GND

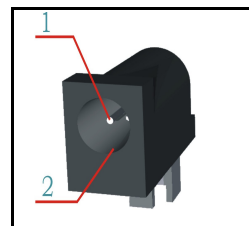

USB HOST

Pin #	Signal Name
1	+5V_HOST_PWR
2	USB_HOST_D-
3	USB_HOST_D+
4	GND

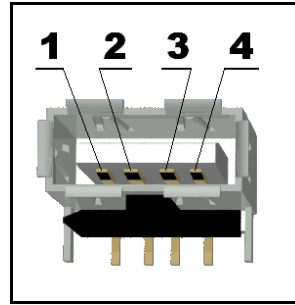

USB OTG

Pin #	Signal Name
1	+5V_OTG_PWR
2	USB_OTG_D-
3	USB_OTG_D+
4	OTG_ID
5	GND

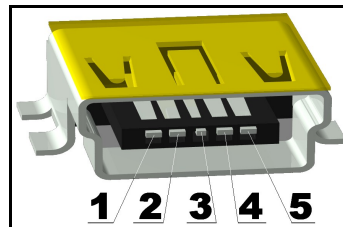

3V BAT

Pin #	Signal Name
1	VBAT
2	GND

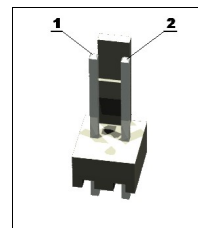

RS232

The RS232 port can be used for communication when in bootloader mode. To enter bootloader mode you need to close RST_E and BOOT0_E jumpers. Note that the default position of those jumpers is closed, e.g. bootloader mode disabled.

Pin #	Signal Name
1	NC
2	T1OUT
3	R1IN
4	NC
5	GND
6	NC
7	CTS
8	RTS
9	NC

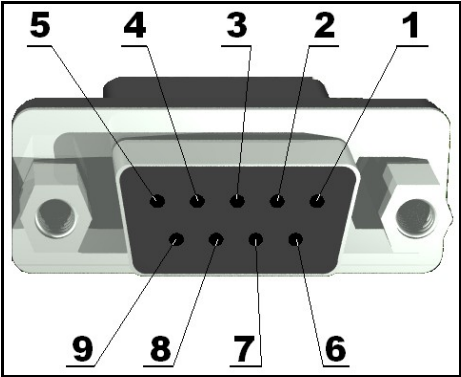

UEXT

Pin #	Signal Name
1	3.3V
2	GND
3	USART2_TX
4	USART2_RX
5	I2C1_SCL
6	I2C1_SDA
7	SPI3_MISO
8	SPI3_MOSI
9	SPI3_SCK
10	CS_UEXT

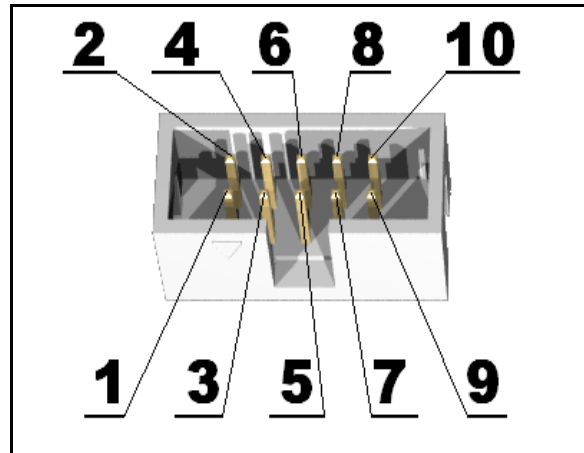

LAN

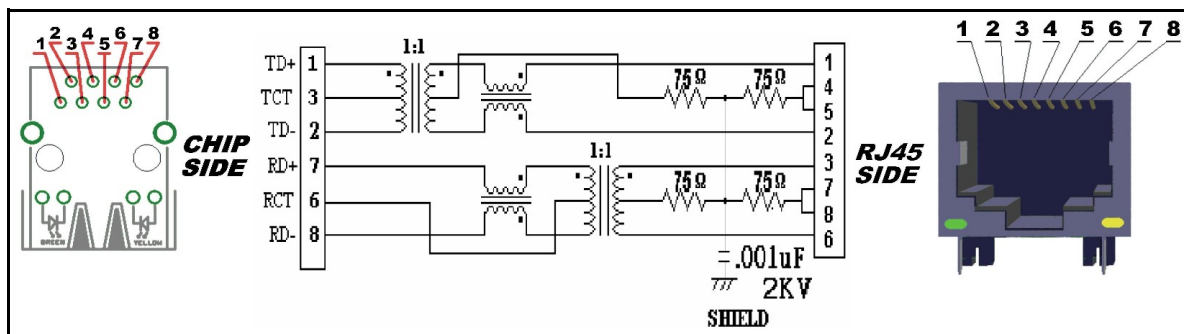

Pin #	Signal Name Chip Side	Pin #	Signal Name Chip Side
1	TX+	5	Not Connected (NC)
2	TX-	6	VDD
3	VDD	7	RX+
4	Not Connected (NC)	8	RX-

LED	Color	Usage
Right	Green	Link status
Left	Yellow	Activity status

SD/MMC

Pin #	Signal Name
1	MCIDAT2
2	CS_MMC
3	SPI3_MOSI
4	3.3V
5	SPI3_SCK
6	GND
7	SPI3_MISO
8	MCIDAT1
9	Not connected
10	Not connected
11	Not connected
12	Not connected

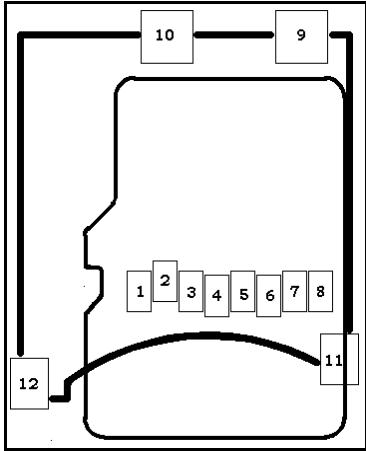

MECHANICAL DIMENSIONS

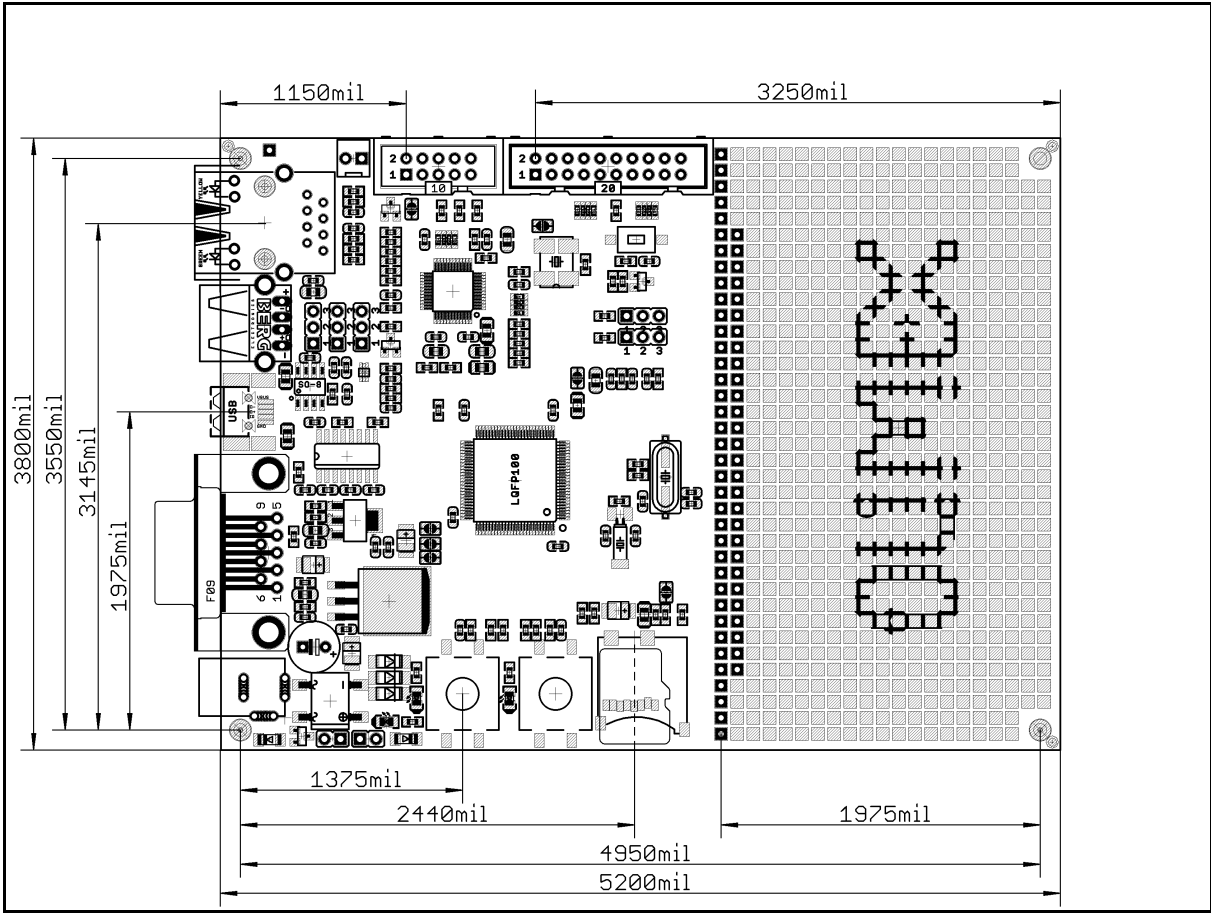

All measures are in mils.

AVAILABLE DEMO SOFTWARE

- [NEW STM32-P107 demo package](#) with Micrel PHY
- [Blinking LED](#) Demo software for EW-ARM 5.50
- [Ethernet](#) Demo software for EW-ARM 5.50
- [USB](#) Demo software for EW-ARM 5.50
- [SD card](#) Demo software for EW-ARM 5.50

ORDER CODE

STM32-P107 – assembled and tested

How to order?

You can order to us directly or by any of our distributors.

Check our web www.olimex.com/dev for more info.

Manual revision history:

REV. Initial	- created December 2009
REV. A	- edited by TU December 2010
REV. B	- demo software added and mechanical dimensions detailed
REV. C	- Rev. A schematic and added more programmers in BOARD USE REQUIREMENTS.
REV. D	- edited June 2011 – changed schematic
REV. E	- changed schematics to rev. B, added board revision history
REV.F	- added BOOT0_E, RST_E description, changed dimensions, updated revision B pictures, updated disclaimer

Board revision history:

rev.A

=====

1. ST2052BD is exchanged with LM3526-L.
2. SD/MMC signals are changed as follows:

SPI1_MOSI	->	SPI3_MOSI
SPI1_SCK	->	SPI3_SCK
SPI1_MISO	->	SPI3_MISO

and SPI1_NSS renamed to CS_MMC

3. Changed the polarity to + of C36

In Rev.B

=====

1. All libraries are updated
2. Ethernet PHY is changed from STE101P to MICREL's one - KS8721BLMM
3. All 10uF/6.3V/TANT are changed to 0805 and a lot of element names are changed.
4. PWR_SEL jumpers are replaced by diodes.
5. USART3 is connected to UEXT while USART2 is connected to RS232 and bootloader functionality is enabled!
Two additional jumpers are added!!!
6. Added UEXT_PWR_E jumper!
7. A lot jumpers are added into jumpers description table

© 2012 Olimex Ltd. Olimex®, logo and combinations thereof, are registered trademarks of Olimex Ltd. Other product names may be trademarks of others and the rights belong to their respective owners.

The information in this document is provided in connection with Olimex products. No license, express or implied or otherwise, to any intellectual property right is granted by this document or in connection with the sale of Olimex products.

The hardware files are closed source. Routing schematics and bill of materials are kept private. You may NOT reproduce the design for commercial use. You may modify the design, but you must then release a link to the creator website: <http://www.olimex.com>.

The software is released under GPL.

It is possible that the pictures in this manual differ from the latest revision of the board.

The product described in this document is subject to continuous development and improvements. All particulars of the product and its use contained in this document are given by OLIMEX in good faith. However all warranties implied or expressed including but not limited to implied warranties of merchantability or fitness for purpose are excluded. This document is intended only to assist the reader in the use of the product. OLIMEX Ltd. shall not be liable for any loss or damage arising from the use of any information in this document or any error or omission in such information or any incorrect use of the product.

This evaluation board/kit is intended for use for engineering development, demonstration, or evaluation purposes only and is not considered by OLIMEX to be a finished end-product fit for general consumer use. Persons handling the product must have electronics training and observe good engineering practice standards. As such, the goods being provided are not intended to be complete in terms of required design-, marketing-, and/or manufacturing-related protective considerations, including product safety and environmental measures typically found in end products that incorporate such semiconductor components or circuit boards.

Olimex currently deals with a variety of customers for products, and therefore our arrangement with the user is not exclusive. Olimex assumes no liability for applications assistance, customer product design, software performance, or infringement of patents or services described herein.

THERE IS NO WARRANTY FOR THE DESIGN MATERIALS AND THE COMPONENTS USED TO CREATE STM32-P107. THEY ARE CONSIDERED SUITABLE ONLY FOR STM32-P107.