

DB151S-DB157S

Silicon Bridge Rectifiers

VOLTAGE RANGE: 50 --- 1000 V

CURRENT: 1.5 A



DB-S

Features

- ◇ Rating to 1000V PRV
- ◇ Surge overload rating to 30 Amperes peak
- ◇ Glass passivated chip junctions
- ◇ Reliable low cost construction utilizing molded plastic technique results in inexpensive product
- ◇ Lead solderable per MIL-STD-202 method 208
- ◇ Lead: silver plated copper, solderde plated
- ◇ Plastic material has UL flammability classification 94V-O
- ◇ Polarity symbols molded on body
- ◇ Weight: 0.016 ounces,0.45 grams

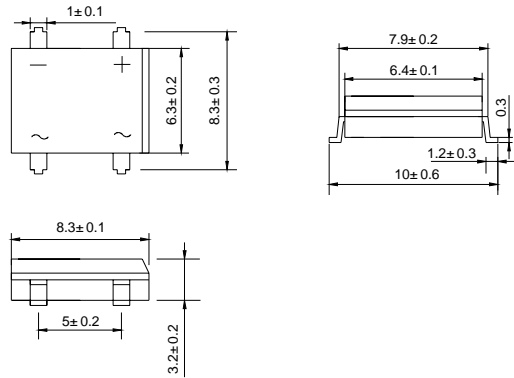

Dimensions in millimeters

MAXIMUM RATINGS AND ELECTRICAL CHARACTERISTICS

Ratings at 25°C ambient temperature unless otherwise specified.

Single phase, half wave, 60 Hz, resistive or inductive load. For capacitive load, derate by 20%.

		DB 151S	DB 152S	DB 153S	DB 154S	DB 155S	DB 156S	DB 157S	UNITS
Maximum recurrent peak reverse voltage	V_{RRM}	50	100	200	400	600	800	1000	V
Maximum RMS voltage	V_{RMS}	35	70	140	280	420	560	700	V
Maximum DC blocking voltage	V_{DC}	50	100	200	400	600	800	1000	V
Maximum average forward Output current @ $T_A=25^\circ C$	$I_{F(AV)}$	1.5							A
Peak forward surge current 8.3ms single half-sine-wave superimposed on rated load	I_{FSM}	40							A
Maximum instantaneous forward voltage at 1.5 A	V_F	1.1							V
Maximum reverse current @ $T_A=25^\circ C$ at rated DC blocking voltage @ $T_A=100^\circ C$	I_R	10.0 1.0							μA mA
Operating junction temperature range	T_J	- 55 ---- + 150							°C
Storage temperature range	T_{STG}	- 55 ---- + 150							°C

Ratings AND Characteristic Curves

FIG.1 – TYPICAL FORWARD CURRENT DERATING CURVE

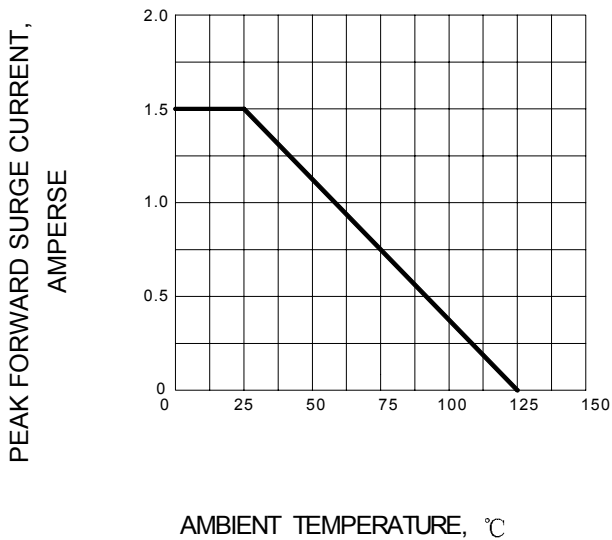

FIG.2 – MAXIMUM NON-REPETITIVE FORWARD SURGE CURRENT

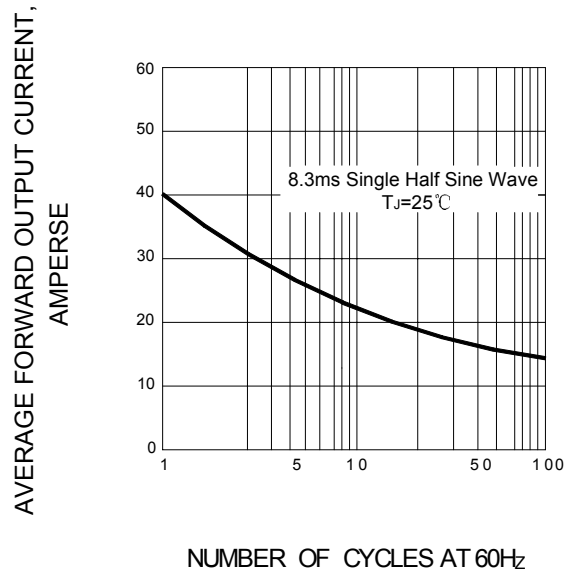

FIG.3 – TYPICAL FORWARD CHARACTERISTIC

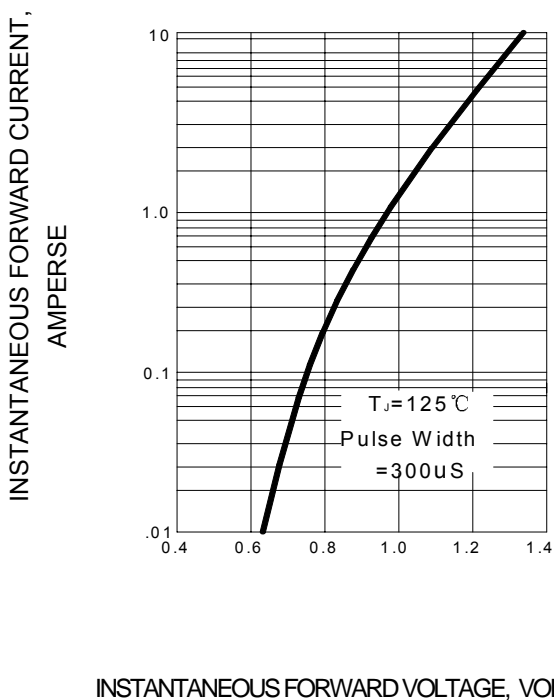

FIG.4 – TYPICAL REVERSE CHARACTERISTIC

