

# INSTRUMENTATION ETC. ENCLOSURES

SERIES  
400

This line of moulded project enclosures is ideally suited for for instance instrumentation and tele-communications equipment from hand-held to desk top sizes. Available in many sizes in ABS.

## DESIGN FEATURES:

- \* Design according to IP54 IEC 529.
- \* Two part design with tongue and groove joint between top and bottom covers.
- \* Internal guide slots provided for vertical mounting of PCB's.
- \* Type 401 - 404 are supplied with pins for horizontal mounting by cold pressing of a PCB or with screw holes for horizontal mounting of a PCB, assembled by means of selfcutting screws.

## ORDERING INFORMATION:

- \* Type numbers are for enclosures supplied with four lid fixing screws and two end panels.
- \* The ABS case lid and base are moulded in grey with end panels in matching colours.
- \* All enclosures can be made according to customer specifications.

● All measurements are in mm.

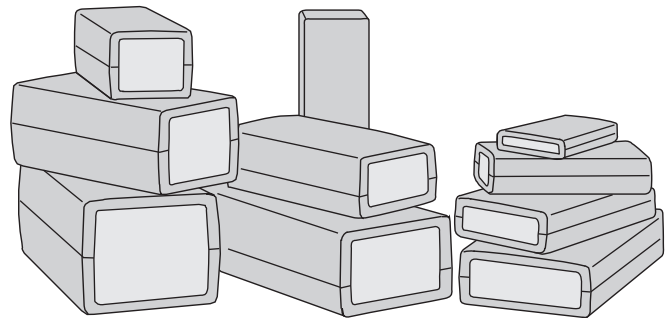

## TECHNICAL DATA:

Material:	ABS (Other materials available)
Colour:	Grey (RAL7035) (Other colours are upon request available)
Assembling:	4 selftapping screws
Sealing:	IP54 IEC 529
Temperature range:	-30°C - +75°C
Self-extinguishing:	ACC UL94-VO

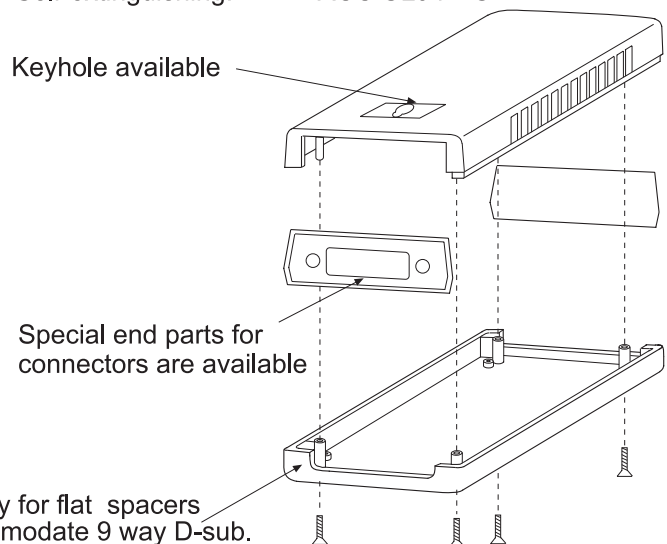

# TYPE 401 + 403 + 404

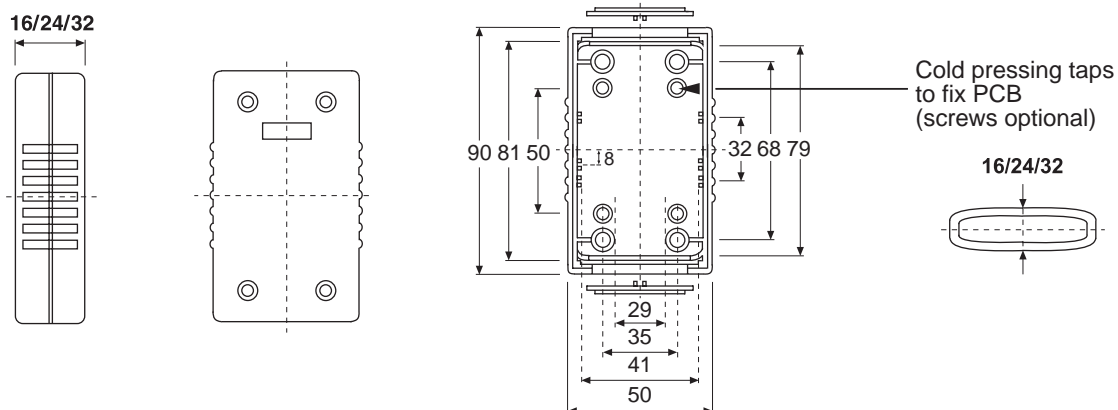

# PCB DIMENSIONS FOR 401 + 403 + 404

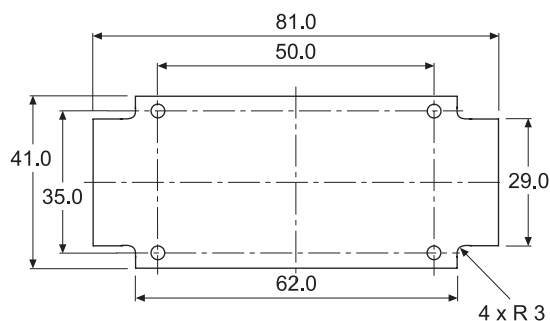

# TYPE 413

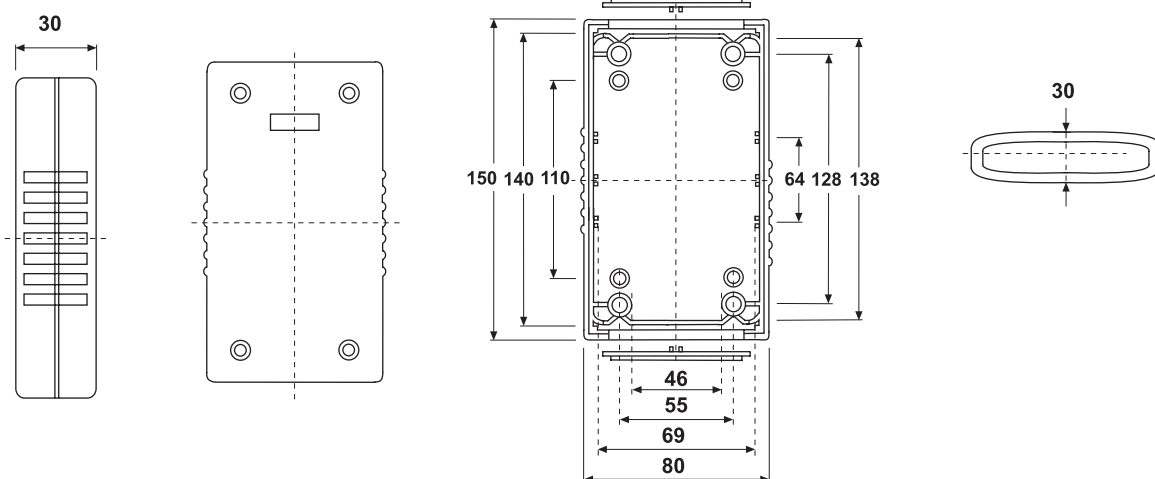

# PCB DIMENSIONS FOR 413

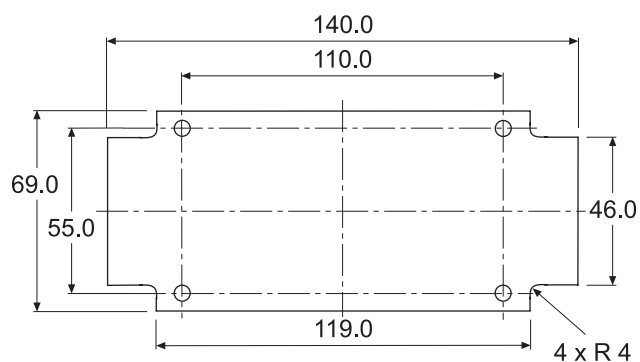

• All measurements are in mm.