

EDR 2 0 1A 05 00 Z
| | | | | | |
| | | | | | +--- Z:RoHS Compliant
| | | | | | +--- Special Code:00~99
| | | | | +--- Nominal voltage:
| | | | | 05:5VDC
| | | | | 12:12VDC
| | | | | 24:24VDC
| | | +--- Contact form:
| | | 1A:Open type, 1 form A
| | | 2A:Open type, 2 form A
| | | 1B:Close type, 1 form B
| | | 1C:1 open 1 close type, 1 form C
| | +--- Function:
| | 0:Normal function
| | D:With diode type
| | H:High insulation
| | K:High insulation with diode type
| +--- Type:
| 2:DIP type
| 3:SMD type
+--- Series name

SPECIFICATIONS

● COIL RATING

Contact form	Nominal Voltage(VDC)	Max. Operate Voltage(VDC)	Pull-in Voltage(VDC)	Dropout Voltage(VDC)	※Coil Resistance(Ω)	Nominal input power(mW)
1A	5	16	3.75	0.8	500±10%	50
	12	20	9.00	1.0	1000±10%	144
	24	32	18.00	2.0	2150±10%	268
2A	5	11	3.75	0.8	140±10%	179
	12	20	9.00	1.0	500±10%	288
	24	32	18.00	2.0	2150±10%	268
1B	5	6	4.20	0.6	500±10%	50
	12	14.5	9.00	1.0	1000±10%	144
	24	29	18.00	2.0	2150±10%	268
1C	5	11	3.75	0.8	200±10%	125
	12	20	9.00	1.0	500±10%	288
	24	32	18.00	2.0	2150±10%	268

※Special design are available on request.

CONTACT RATING

Contact form		1A	2A	1B	1C
Switching current		0.5 ADC Max.	0.5 ADC Max.	0.5 ADC Max.	0.2 ADC Max.
Carry current		1.0 ADC Max.	1.0 ADC Max.	1.0 ADC Max.	0.5 ADC Max.
Switching power		10 VA Max.	10 VA Max.	10 VA Max.	3 VA Max.
Electrical life		1x10 ⁸ (Ref 10VDC,10mA)	1x10 ⁸ (Ref 10VDC,10mA)	1x10 ⁸ (Ref 10VDC,10mA)	5x10 ⁷ (Ref 5VDC,1mA)
Contact resistance		150mΩ Max.	150mΩ Max.	150mΩ Max.	150mΩ Max.
Operate time (including bounce time)		1.0ms Max.	1.0ms Max.	1.0ms Max.	1.5ms Max.
Release time		0.5ms Max.	0.5ms Max.	0.5ms Max.	2.0ms Max.
Maximum voltage		100 VDC Max.	100 VDC Max.	100 VDC Max.	30 VDC Max.
Insulation resistance (at 100 VDC)		10 ¹⁰ Ω Min.	10 ¹⁰ Ω Min.	10 ¹⁰ Ω Min.	10 ⁹ Ω Min.
Dielectric strength	Coil to contact	1400 VDC Min. (General) 4000 VDC Min. (High insulation)	1400 VDC Min.	1400 VDC Min.	1400 VDC Min.
	Across contacts	250 VDC Min.	250 VDC Min.	250 VDC Min.	150 VDC Min.
Temperature range					
Operating temperature		-40℃ ~ +85℃	-40℃ ~ +85℃	-40℃ ~ +85℃	-40℃ ~ +85℃
Storage temperature		-55℃ ~ +125℃	-55℃ ~ +125℃	-55℃ ~ +125℃	-55℃ ~ +125℃
Shock resistance		30G Min.	30G Min.	30G Min.	30G Min.

DIMENSIONS

SIP TYPE

DIMENSIONS UNIT:mm(inch)

EDR10(D)1AXXXX (PIN OUT 1357)

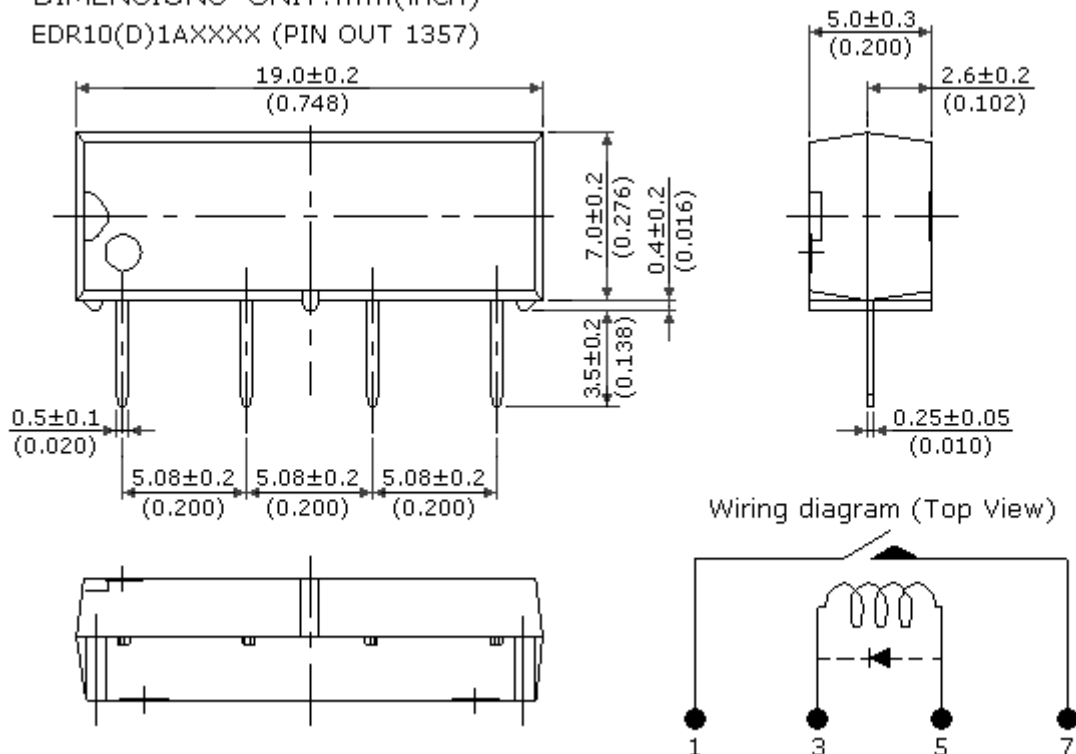

DIMENSIONS UNIT: mm(inch)

EDR10(D)1AXX5X (PIN OUT 1267)

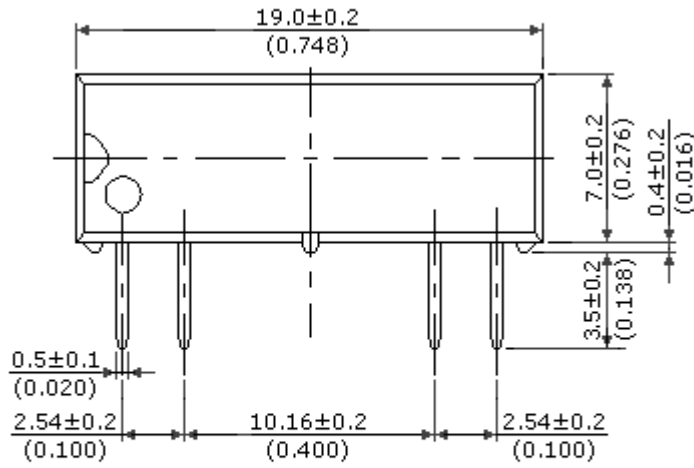

Wiring diagram (Top View)

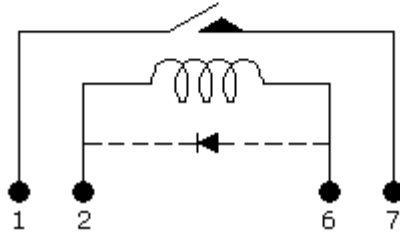

DIMENSIONS UNIT: mm(inch)

EDR1M(N)1AXXXX (PIN OUT 1357)

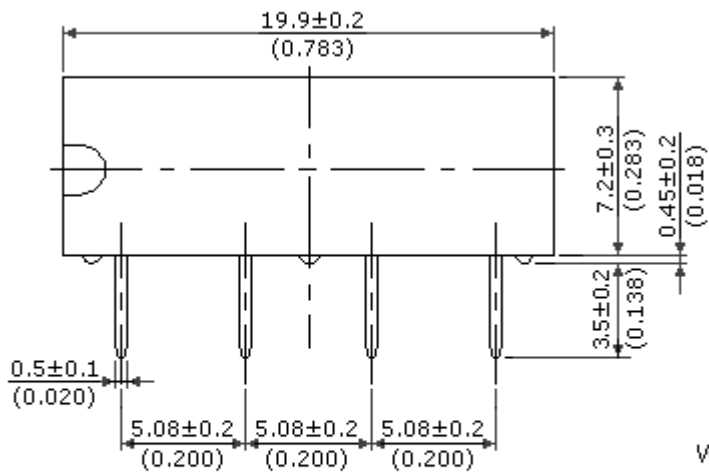

Wiring diagram (Top View)

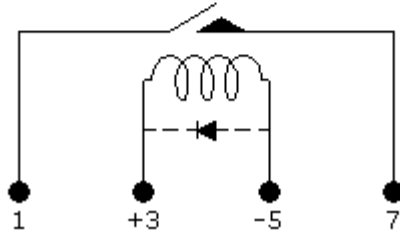

DIMENSIONS UNIT:mm(inch)

EDR1M(N)1AXX5X (PIN OUT 1267)

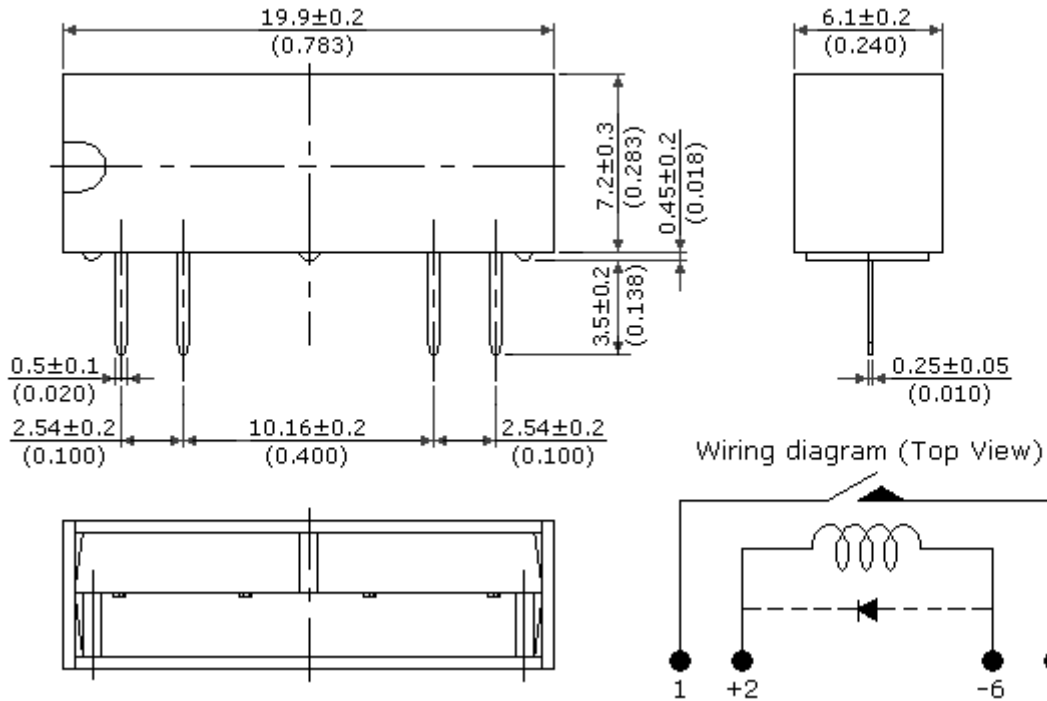

● **DIP TYPE / SMD TYPE**

DIMENSIONS UNIT:mm(inch)

(DIP TYPE)

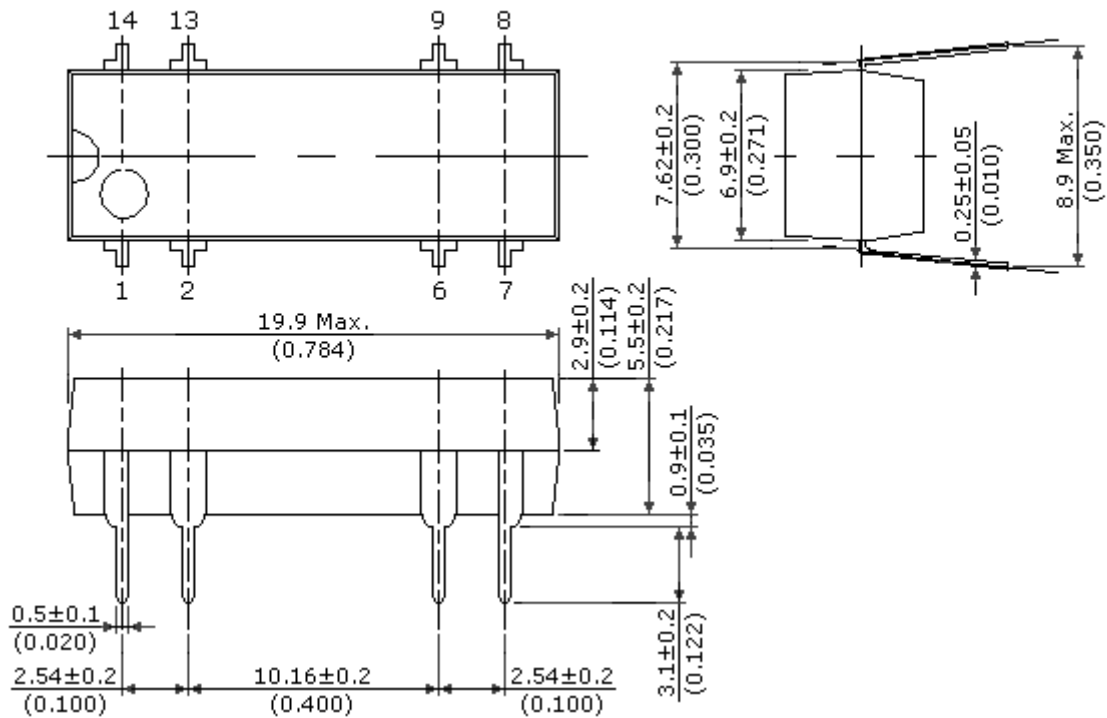

DIMENSIONS UNIT:mm(inch)

(SMD-SO TYPE)

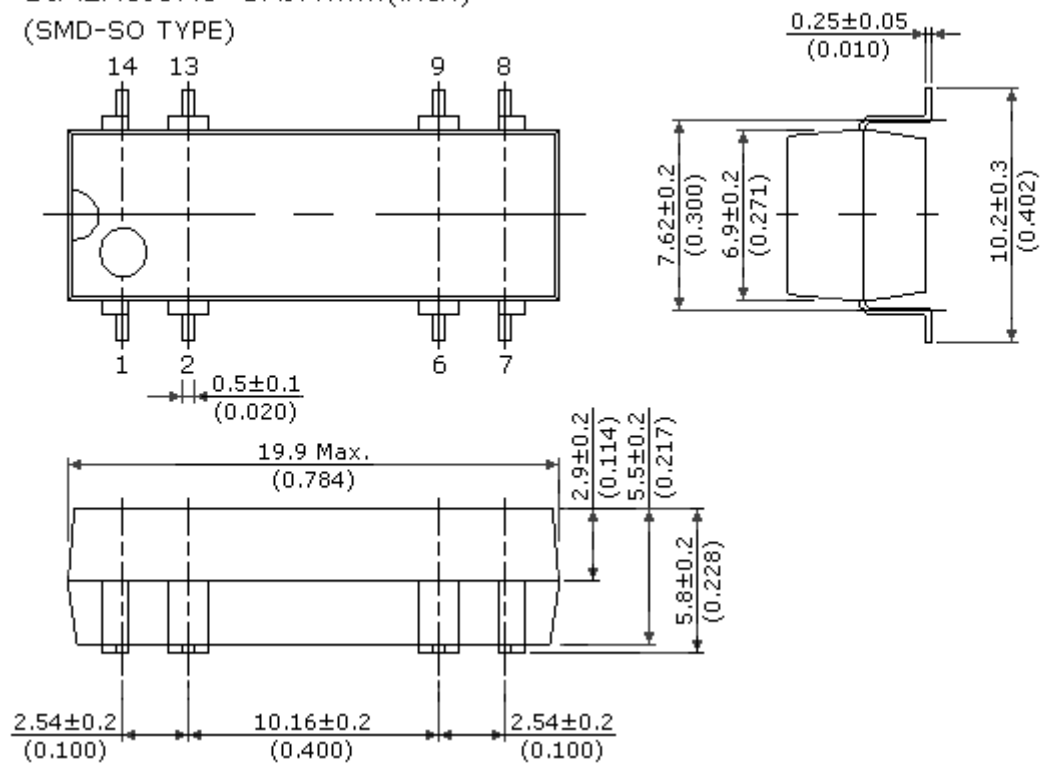

Wiring diagram (Top View)

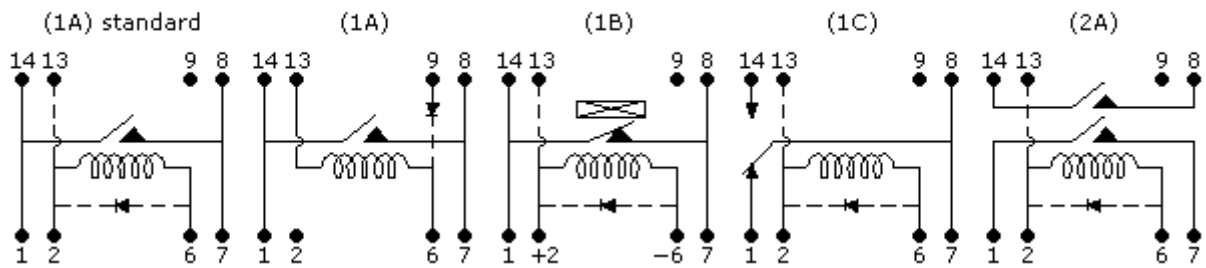

● HIGH INSULATION TYPE

DIMENSIONS UNIT:mm(inch)

(DIP TYPE)

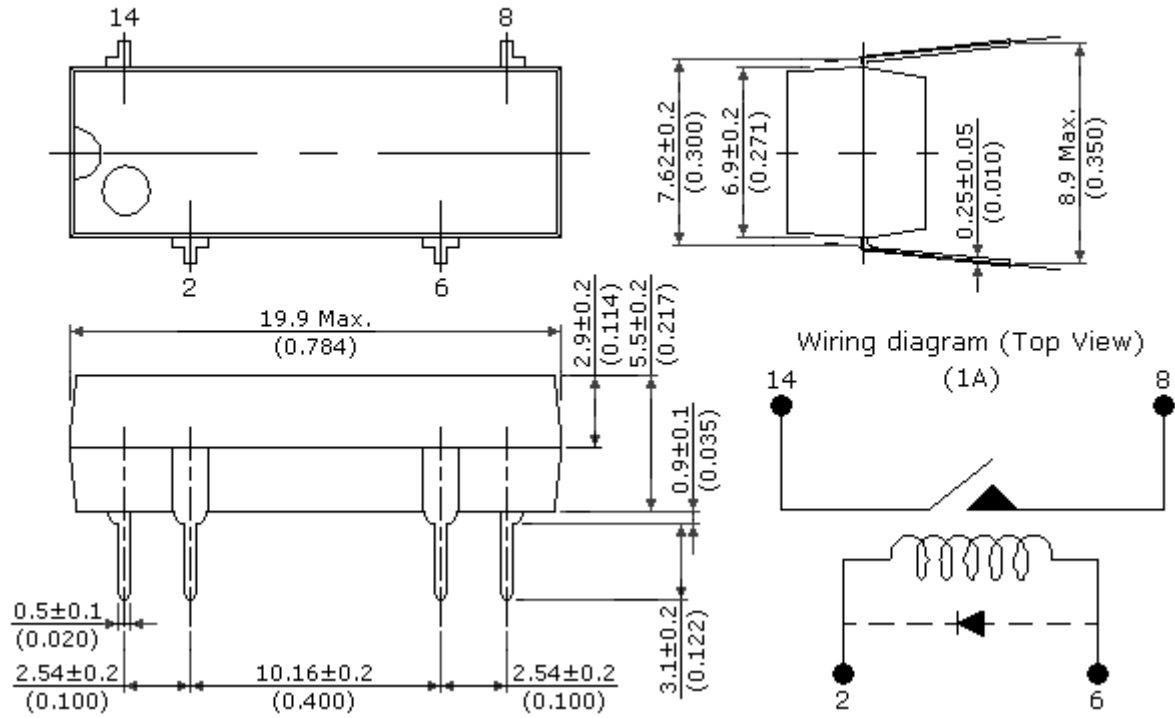

DIMENSIONS UNIT:mm(inch)

(SMD-SO TYPE)

