

Part Number: KB2855SGW SUPER BRIGHT GREEN

### Features

- UNIFORM LIGHT EMITTING AREA.
- EASILY MOUNTED ON P.C. BOARDS.
- FLUSH MOUNTABLE.
- EXCELLENT ON/OFF CONTRAST.
- CAN BE USED WITH PANELS AND LEGEND MOUNTS.
- RoHS COMPLIANT.

### Description

The Super Bright Green source color devices are made with Gallium Phosphide Green Light Emitting Diode.

### Package Dimensions & Internal Circuit Diagram

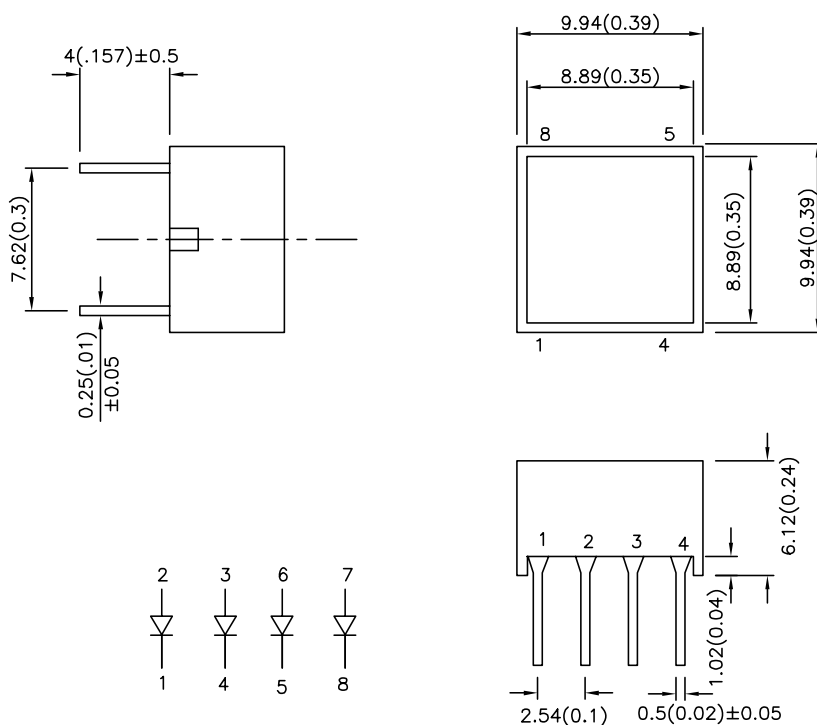

#### Notes:

1. All dimensions are in millimeters (inches), Tolerance is  $\pm 0.25(0.01)$  unless otherwise noted.
2. Specifications are subject to change without notice.

## Selection Guide

Part No.	Dice	Lens Type	Iv (mcd) [1] @ 20mA	
			Min.	Typ.
KB2855SGW	SUPER BRIGHT GREEN (GaP)	WHITE DIFFUSED	18	79.5

Note:

- Luminous intensity / luminous flux: +/-15%.

## Electrical / Optical Characteristics at TA=25°C

Symbol	Parameter	Device	Typ.	Max.	Units	Test Conditions
$\lambda_{peak}$	Peak Wavelength	Super Bright Green	565		nm	IF=20mA
$\lambda_D$ [1]	Dominant Wavelength	Super Bright Green	568		nm	IF=20mA
$\Delta\lambda_{1/2}$	Spectral Line Half-width	Super Bright Green	30		nm	IF=20mA
C	Capacitance	Super Bright Green	15		pF	VF=0V;f=1MHz
VF [2]	Forward Voltage	Super Bright Green	2.2	2.5	V	IF=20mA
IR	Reverse Current	Super Bright Green		10	uA	VR = 5V

Notes:

- Wavelength: +/-1nm.
- Forward Voltage: +/-0.1V.

## Absolute Maximum Ratings at TA=25°C

Parameter	Super Bright Green	Units
Power dissipation	105	mW
DC Forward Current	25	mA
Peak Forward Current [1]	140	mA
Reverse Voltage	5	V
Operating/Storage Temperature	-40°C To +85°C	
Lead Solder Temperature [2]	260°C For 5 Seconds	

Notes:

- 1/10 Duty Cycle, 0.1ms Pulse Width.
- 2mm below package base.

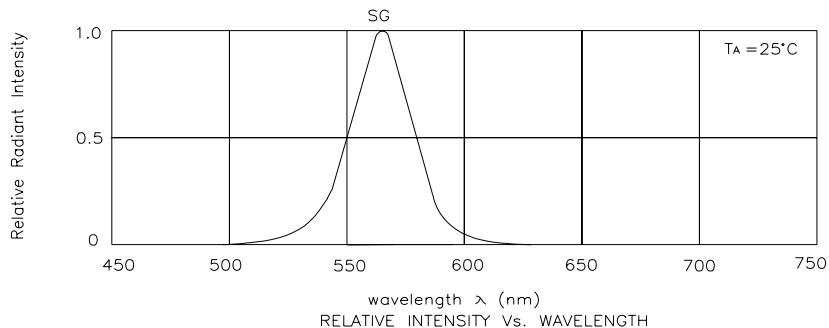

## Super Bright Green

## KB2855SGW

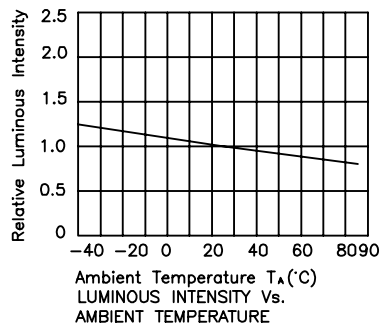
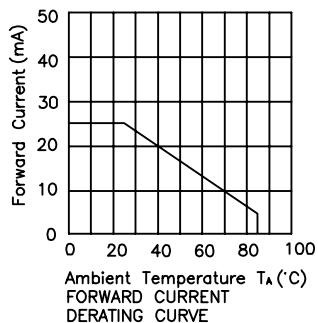
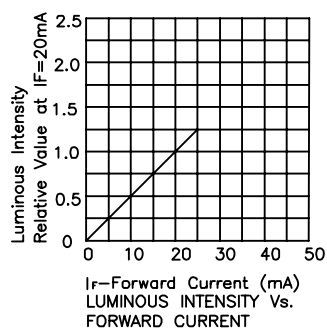
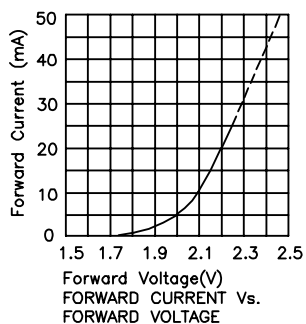

## PACKING & LABEL SPECIFICATIONS

## KB2855SGW

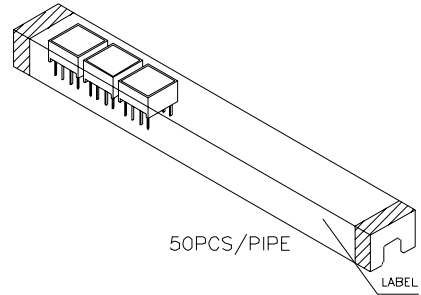
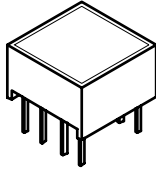

50PCS/PIPE

LABEL

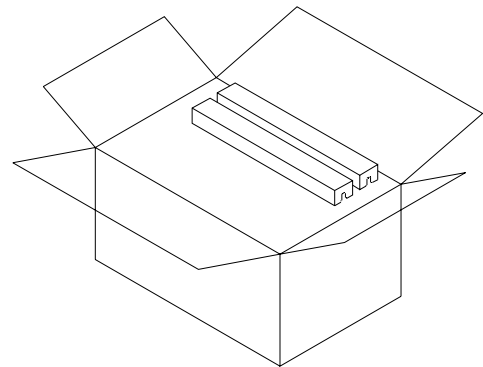

210PIPE/10#BOX

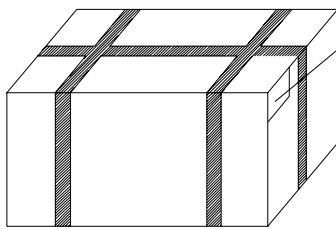

OUTSIDE LABEL

10500PCS/BOX

Inside LABEL Paste On The IC-pipe

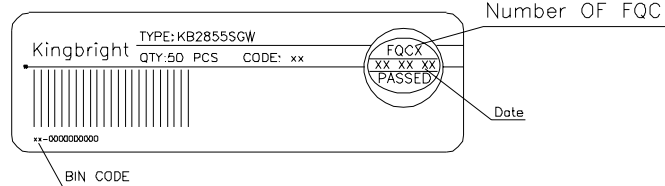

Outside LABEL Paste On The Box

