

# Stepping motor driver

## BA6845FS

The BA6845FS is a stepping motor driver with a maximum output current of 1.0A. The logic input allows three output modes : forward, reverse, and power save. The IC has a low output saturation voltage and is capable of driving motors at low supply voltage.

### ●Applications

Stepping motors for floppy disk drives

### ●Features

- 1) Low output saturation voltage.
- 2) Power save circuit.
- 3) Thermal shutdown circuit.

### ●Absolute maximum ratings (Ta = 25°C)

| Parameter                | Symbol             | Limits             | Unit |
|--------------------------|--------------------|--------------------|------|
| Applied voltage          | V <sub>CC</sub>    | 12                 | V    |
| Power dissipation        | P <sub>d</sub>     | 800* <sup>1</sup>  | mW   |
| Operating temperature    | T <sub>opr</sub>   | -25~+75            | °C   |
| Storage temperature      | T <sub>stg</sub>   | -55~+150           | °C   |
| Allowable output current | I <sub>oMax.</sub> | 1000* <sup>2</sup> | mA   |

\*1 When mounted on a glass epoxy PCB (90 X 50 X 1.6 mm) board.

Reduced by 6.4 mW for each increase in Ta of 1°C over 25°C.

\*2 Should not exceed Pd- or ASO-value.

### ●Recommended operating conditions (Ta = 25°C)

| Parameter            | Symbol          | Limits  | Unit |
|----------------------|-----------------|---------|------|
| Power supply voltage | V <sub>CC</sub> | 2.7~9.0 | V    |

●Block diagram

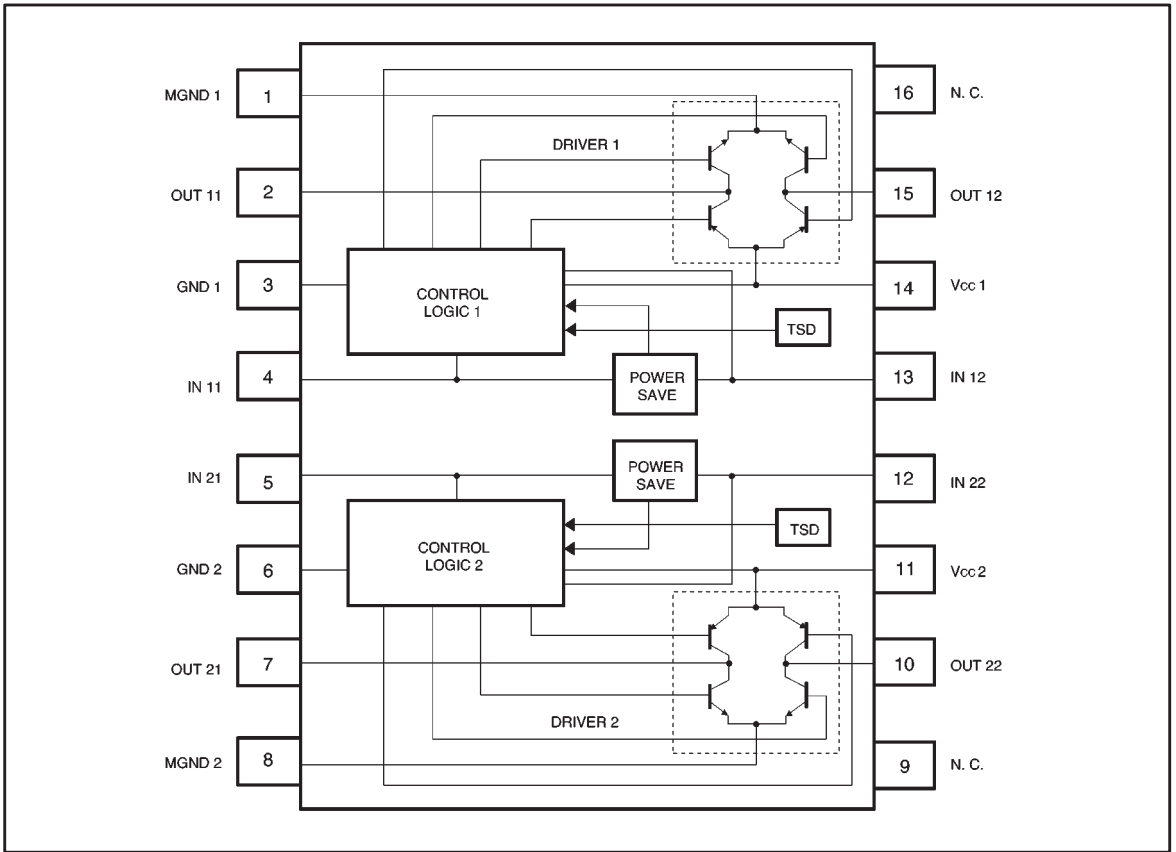

● Pin descriptions

| Pin No. | Pin name          | Function     |
|---------|-------------------|--------------|
| 1       | MGND 1            | Motor ground |
| 2       | OUT 11            | Motor output |
| 3       | GND 1             | Ground       |
| 4       | IN 11             | Logic input  |
| 5       | IN 21             | Logic input  |
| 6       | GND 2             | Ground       |
| 7       | OUT 21            | Motor output |
| 8       | MGND 2            | Motor ground |
| 9       | N. C.             | N. C.        |
| 10      | OUT 22            | Motor output |
| 11      | V <sub>CC</sub> 2 | Power supply |
| 12      | IN 22             | Logic input  |
| 13      | IN 12             | Logic input  |
| 14      | V <sub>CC</sub> 1 | Power supply |
| 15      | OUT 12            | Motor output |
| 16      | N. C.             | N. C.        |

● Input / output circuits (all resistances are typical values)

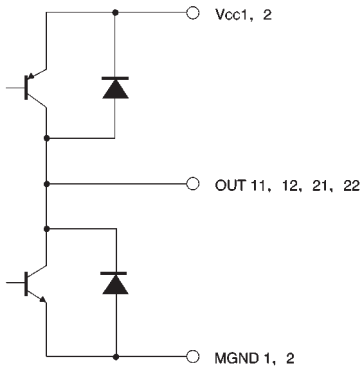
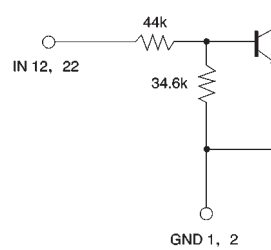
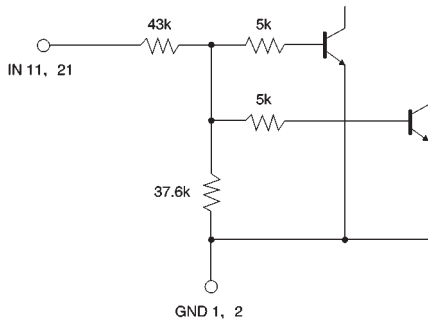

●Electrical characteristics (unless otherwise noted,  $T_a = 25^\circ\text{C}$ ,  $V_{CC} = 5\text{V}$ )

| Parameter                 | Symbol    | Min. | Typ. | Max. | Unit          | Conditions  |
|---------------------------|-----------|------|------|------|---------------|---|
| Supply current 1          | $I_{CC1}$ | —    | 55   | 80   | mA            | $IN12=IN22=5\text{V}$   |
| Supply current 2          | $I_{CC2}$ | —    | —    | 10   | $\mu\text{A}$ | $IN12=IN22=0\text{V}$   |
| Output saturation voltage | $V_{SAT}$ | —    | 0.5  | 0.7  | V             | $I_{OUT}=400\text{mA}$ , sum of the high-and low-side voltage |
| Input threshold voltage   | $V_{IN}$  | 1.0  | 1.5  | 2.1  | V             |   |
| Input current             | $I_{IN}$  | —    | 100  | 150  | $\mu\text{A}$ | $IN11, 12, 21, 22=5\text{V}$                                  |

◎Not designed for radiation resistance.

●Truth table

| IN11 / 21 | IN12 / 22 | OUT11 / 21 | OUT12 / 22 | Mode    |
|-----------|-----------|------------|------------|---------|
| L         | H         | H          | L          | Forward |
| H         | H         | L          | H          | Reverse |
| L         | L         | OPEN       | OPEN       | Stop    |
| H         | L         | OPEN       | OPEN       | Stop    |

## ●Application example

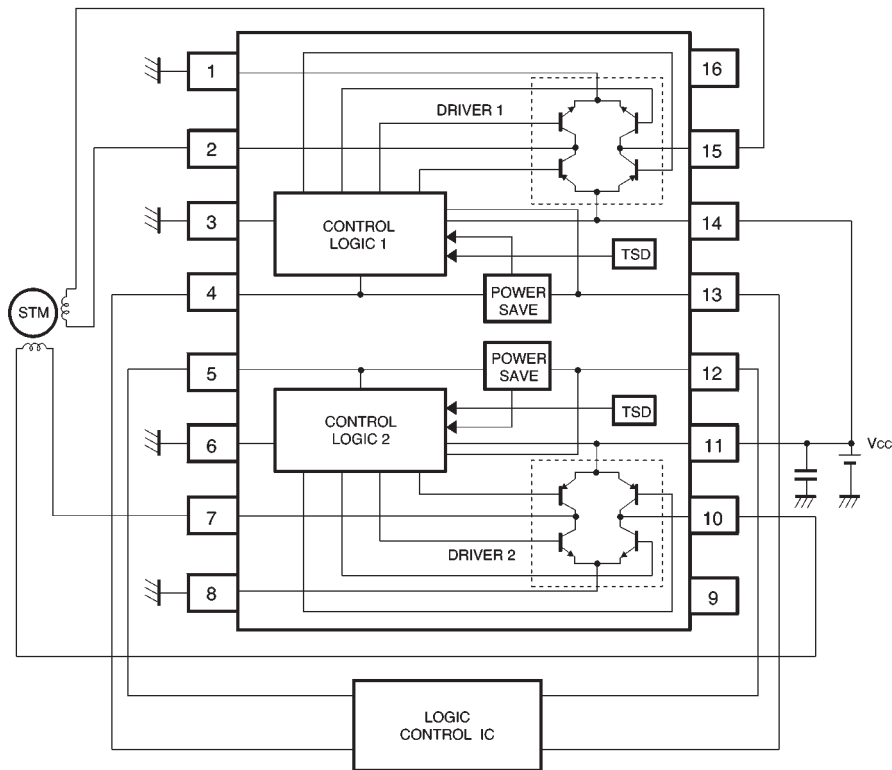

Fig.1

## ●Operation notes

## (1) Control logic pins

Do not apply voltage to control logic pins (pins 4, 5, 12, and 13) when the  $V_{CC}$  voltage is not applied to the IC. The voltage of each pin should be less than  $V_{CC}$ , if applied, and should be more than the ground voltage.

## (2) PCB arrangement

When changing the rotational direction of a motor, a large current of up to a few hundred milliamperes can flow between the motor power supply (pins 11 and 14) and MGND (pins 1 and 8). Depending on the application, this large output current may flow back to input pins, resulting in output oscillation or other malfunctions. Make sure that your design does not allow a common impedance between the large current output lines and the input section. Suppress the power supply impedance to low levels, otherwise output oscillation may occur.

## (3) Package power dissipation

The power dissipated by the IC varies widely with the supply voltage and the output current. Give full consideration to the package power dissipation rating when setting the supply voltage and the output current.

## (4) Ground pins

Pins 1, 3, 6, and 8 should have the lowest potential (ground potential) in the IC.

## (5) Thermal shutdown circuit

This circuit shuts down all the driver outputs when the chip junction temperature is increased to about 175°C (typical). The thermal shutdown circuit is deactivated when the temperature drops to about 20°C (typical).

## (6) Input pins (pins 4, 5, 12, and 13)

These pins have characteristics negatively correlated to temperature. Give full consideration to the temperature effect when using the IC.

● Electrical characteristic curves

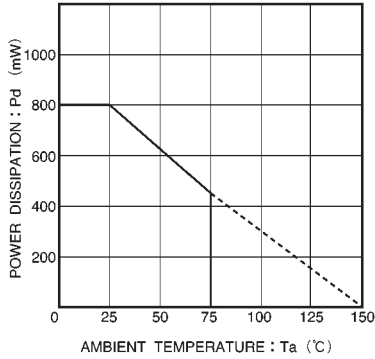

Fig.2 Power dissipation curve

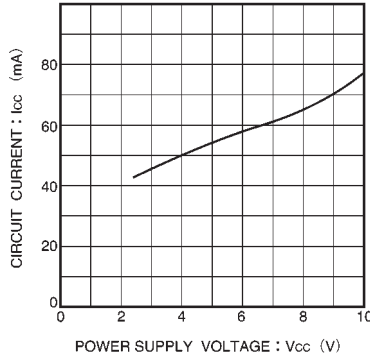

Fig.3 Circuit current vs. power supply voltage

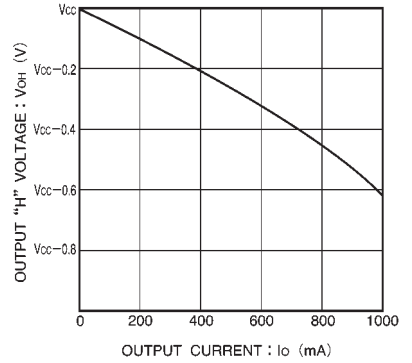

Fig.4 HIGH level output voltage vs. output current

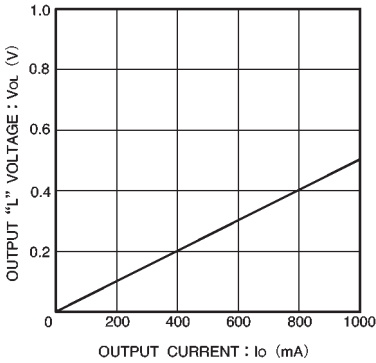

Fig.5 LOW level output voltage vs. output current

● External dimensions (Units: mm)

