

# ANTARIS<sup>®</sup> 4 GPS Modules

System Integration Manual (SIM)  
(incl. Reference Design)



## Abstract

This document describes the features of u-blox's ANTARIS<sup>®</sup> 4 GPS modules. These modules combine excellent GPS performance, SuperSense<sup>™</sup> ability and low power consumption in the compact and very popular TIM and LEA form factors and the even smaller NEO form factor.



This manual applies to all ANTARIS<sup>®</sup> 4 GPS receivers based on Firmware 5.00 and above.

*your position is our focus*

<b>Title</b>	GPS Modules		
<b>Subtitle</b>	System Integration Manual (SIM)	(incl. Reference Design)	
<b>Doc Type</b>	Manual		
<b>Doc Id</b>	GPS.G4-MS4-05007-A1		
<b>Revision Index</b>	<b>Date</b>	<b>Name</b>	<b>Status / Comments</b>
Initial Version	13/03/2006	TC	
A		TG	Naming Convention, LEA-4M, NEO-4S, static hold mode, aiding
A1	24/05/2007	TG	Dead Reckoning, Product Categories, Choosing the Optimal Module, Layout (Pastemask), Active Antenna Supervisor, Packaging (Reels), Conformal Coating, System Sensitivity Test, Mechanical Dimensions/ Pinout

We reserve all rights to this document and any information contained therein. Reproduction, use or disclosure to third parties without express permission is strictly prohibited.

For most recent documents, please visit [www.u-blox.com](http://www.u-blox.com)

	Products marked with this lead-free symbol on the product label comply with the "Directive 2002/95/EC of the European Parliament and the Council on the Restriction of Use of certain Hazardous Substances in Electrical and Electronic Equipment" (RoHS).
	This is an Electrostatic Sensitive Device (ESD). Observe precautions for handling.

Performance characteristics shown in this document are estimates only and do not constitute a warranty or guarantee of product performance. u-blox does not support any applications in connection with weapon systems. Since u-blox' products are not designed for use in life-support and commercial aviation applications they shall not be used in such products. In devices or systems whereby malfunction of these products can be expected to result in personal injury and casualties, u-blox customers using or selling these products do so at their own risk and agree to keep u-blox harmless from any consequences. u-blox reserves the right to make changes to this product, including its circuits and software, in order to improve its design and/or performance, without prior notice.

u-blox makes no warranties, neither expressed nor implied, regarding the information and specifications contained in this document. u-blox assumes no responsibility for any claims or damages arising from information contained in this document, or from the use of products and services detailed therein. This includes, but is not limited to, claims or damages based on the infringement of patents, copyrights, mask work and/or other intellectual property rights.

u-blox integrated circuits, software and designs are protected by intellectual property laws in Switzerland and abroad. u-blox, the u-blox logo, the TIM-type GPS module, Antaris, SuperSense, "your position is our focus", NavLox, u-center, AssistNow, AlmanacPlus, FixNow and EKF are (registered) trademarks of u-blox AG. This product may in whole or in part be subject to intellectual property rights protection. Please contact u-blox for any additional information. Copyright © 2007, u-blox AG.

# I Preface

The ANTARIS<sup>®</sup>4 System Integration Manual provides the necessary information to successfully design in and configure these ANTARIS<sup>®</sup> based GPS receivers. The chapter below helps you to navigate this manual and to find the information you are looking for as quickly as possible.

## I.1 How to use this Manual

This manual has a modular structure. It is not necessary to read from the beginning to the end.

Focus on sections remarked with **A4** for ANTARIS<sup>®</sup>4 if you are familiar with ANTARIS<sup>®</sup> technology.

Skip *Section 1* if you are already familiar with GPS but in any case read the Receiver Description in *Section 4* carefully. It not only provides an overview about the features and benefits of ANTARIS<sup>®</sup>4 GPS technology but also contains the necessary information required to fully exploit the benefits of this powerful GPS technology.

In order to help you in finding the information you need, we provide a brief section overview. You will find the table of contents at the beginning and the index (*page 178*), list of figures (*page 180*) and the list of tables (*page 182*) at the end of this document.

### 1. GPS Fundamentals

This chapter provides an overview over the GPS system and functionality. There is very useful information about the different antenna types available on the market and how to reduce interference in your design containing a GPS receiver.

### 2. System Consideration

This chapter helps to decide which receiver is fitting the best. It explains the difference about Low Cost -, Programmable, SuperSense<sup>®</sup> GPS and DR enabled receivers and the two available form factors TIM and LEA.

### 3. Design-In

This chapter provides all Design-In information for a successful design and offers guidelines for migration to ANTARIS<sup>®</sup>4 designs.

### 4. Receiver Description

This chapter describes the function of ANTARIS<sup>®</sup>4 GPS Technology for navigation and positioning. It also provides information on how to connect and implement an ANTARIS<sup>®</sup>4 GPS receiver in a user application. It includes a minimal configuration schematic as well as one incorporating optional functions.

### 5. Product Handling

This chapter defines packaging, handling, shipment, storage and soldering.

### 6. Product Testing

This chapter provides information about testing of OEM receivers in production.

### 7. PC Support Tools

This chapter describes our very useful PC support tools (e.g. u-center) and how to install and use them.

### 8. Troubleshooting

This chapter gives useful hints, when your system is not running as expected.

If you have any questions about u-blox GPS system integration, please:

- Read this manual carefully. Refer to the *Trouble-Shooting Section 8 or Index on page 178*.
- Contact our information service on the homepage <http://www.u-blox.com>
- Read the questions and answers on our FAQ database on the homepage <http://www.u-blox.com>

### **u-blox Glossary and Abbreviations**

Every technology has its own language. To assure a precise terminology we provide a general *GPS dictionary [1]* on our website. Feel free to download this information for a better understanding of our documents.

## **I.2 Technical Support**

### **Worldwide Web**

Our website ([www.u-blox.com](http://www.u-blox.com)) is a rich pool of information. Product information, technical documents and helpful FAQ can be accessed 24h a day.

### **By E-mail**

If you have technical problems or cannot find the required information in the provided documents, contact the nearest of the Technical Support offices by email. Use our service pool email addresses rather than any personal email address of our staff. This makes sure that your request is processed as soon as possible. You will find the contact details at the end of the document.

### **By Phone**

If an email contact is not the right choice to solve your problem or does not clearly answer your questions, call the nearest Technical Support office for assistance. You will find the contact details at the end of the document.

### **Helpful Information when Contacting Technical Support**

If you contact Technical Support please have the following information ready:

- Receiver type (e.g. TIM-4P) and firmware version (e.g. V4.00)
- Receiver configuration, e.g. in form of a u-center configuration file (see *Section 7.2.4* for details).
- Clear description of your question or the problem together with u-center logfile (see *Section 7.2*)
- A short description of your application
- Your complete contact details

## II Contents

<b>1</b>	<b>GPS Fundamentals.....</b>	<b>11</b>
1.1	Theory of operation.....	11
1.2	Basic Operation Cycle.....	12
1.3	Start-Up.....	12
1.4	Considerations for GPS Performance.....	14
1.4.1	Dilution of Precision (DOP).....	14
1.4.2	Multipath.....	15
1.5	Antennas.....	16
1.5.1	Selecting the right Antenna.....	16
1.5.2	Active and Passive Antennas.....	17
1.5.3	Patch Antennas.....	17
1.5.4	Helix Antennas.....	19
1.5.7	Helix or Patch, which selection is best?.....	19
1.5.8	Antenna Matching.....	20
1.5.9	Antenna Placement.....	21
1.6	Interference Issues.....	22
1.6.1	Sources of Noise.....	22
1.6.2	Eliminating Digital Noise Sources.....	23
1.6.3	Shielding.....	26
1.7	High Sensitivity GPS (SuperSense® GPS).....	29
1.8	Assisted GPS / A-GPS.....	30
1.9	DGPS (Differential GPS).....	30
1.10	SBAS (Satellite Based Augmentation Systems).....	31
1.11	Dead Reckoning enabled GPS (DR).....	32
1.11.1	Dead Reckoning Principal.....	33
1.11.2	Dead Reckoning Performance.....	33
<b>2</b>	<b>System Consideration.....</b>	<b>35</b>
2.1	Introduction <b>A4</b> .....	35
2.2	Technology <b>A4</b> .....	36
2.2.1	Standard GPS Receivers.....	36
2.2.2	SuperSense® GPS Receiver.....	36
2.2.3	Precision Timing GPS Receivers.....	36
2.2.4	DR enabled Receivers.....	36
2.3	Product Categories.....	36

2.3.1	Low Cost Receivers (ROM only) .....	36
2.3.2	Programmable Receivers (Receivers with integrated FLASH memory) .....	36
2.4	Form Factors .....	37
2.4.1	NEO Modules .....	37
2.4.2	LEA Modules .....	37
2.4.3	TIM Modules .....	38
2.5	Choosing the optimal module .....	39
2.5.1	ANTARIS® 4 Feature Matrix .....	40
2.6	Compatibility of ANTARIS® GPS receivers <b>A4</b> .....	41
2.7	Active vs. Passive Antenna .....	42
<b>3</b>	<b>Design-In.....</b>	<b>43</b>
3.1	Schematic Design-In Checklist for ANTARIS® 4 <b>A4</b> .....	43
3.2	LEA-4x Design <b>A4</b> .....	44
3.3	TIM-4x Design <b>A4</b> .....	47
3.4	NEO-4S Design .....	49
3.5	Layout Design-In Checklist for ANTARIS® 4 <b>A4</b> .....	51
3.6	Layout .....	52
3.6.1	Footprint .....	52
3.6.2	Paste Mask .....	53
3.6.3	Placement .....	54
3.6.4	Antenna Connection and Grounding Plane Design .....	54
3.6.5	Antenna Micro Strip .....	56
3.6.6	Antenna Bias Voltage on NEO-4S and LEA-4M .....	57
<b>4</b>	<b>Receiver Description.....</b>	<b>59</b>
4.1	Overview <b>A4</b> .....	59
4.1.1	Block Schematic <b>A4</b> .....	59
4.2	Power Management .....	61
4.2.1	Connecting Power .....	61
4.2.2	Backup Battery .....	61
4.2.3	Avoiding increased current in low power modes .....	62
4.2.4	Power Saving Modes .....	63
4.2.5	Operating Modes .....	63
4.2.6	Continuous Tracking Mode .....	64
4.2.7	Power Saving Modes (FixNOW™ Mode, FXN).....	65
4.2.8	Externally Controlled Power Management.....	72
4.3	Antenna and Antenna Supervisor .....	72

4.3.1	Passive Antenna .....	72
4.3.2	Active Antenna .....	73
4.3.3	Active Antenna Bias Power .....	74
4.3.4	Active Antenna Supervisor.....	75
4.4	Serial Communication .....	79
4.4.1	USART Ports .....	79
4.4.2	USB Serial Port (LEA-4x and NEO-4S) <span style="background-color: #90EE90; border-radius: 50%; padding: 2px;">A4</span> .....	81
4.4.3	UBX Binary Protocol .....	82
4.4.4	NMEA Protocol.....	85
4.4.5	RTCM Protocol .....	88
4.4.6	How to change between protocols.....	89
4.5	Acquisition .....	89
4.5.1	Coldstart Strategy .....	89
4.5.2	Warmstart Strategy .....	90
4.5.3	Hotstart Strategy .....	90
4.5.4	Aiding / Assisted GPS (AGPS).....	90
4.5.5	AssistNow® Online.....	92
4.5.6	AssistNow® Offline .....	92
4.5.7	SuperSense® GPS - Weak Signal GPS (TIM-4H/ LEA-4H/ TIM-4S/ LEA-4S) .....	93
4.5.8	Sensitivity Settings (Tracking and Acquisition Modes) .....	95
4.6	Navigation .....	96
4.6.1	Overview .....	96
4.6.2	Navigation Update Rate.....	97
4.6.3	Dynamic Platform Model .....	97
4.6.4	Static Hold Mode .....	98
4.6.5	Degraded Navigation.....	99
4.6.6	Almanac Navigation .....	99
4.6.7	Navigation Input Filters.....	100
4.6.8	Navigation Output Filters.....	100
4.6.9	Position Quality Indicators .....	102
4.6.10	DGPS (Differential GPS) .....	105
4.6.11	SBAS (Satellite Based Augmentation Systems) .....	105
4.6.12	RAIM (Receiver Autonomous Integrity Monitoring).....	108
4.7	Timing .....	109
4.7.1	TIMEPULSE .....	109
4.7.2	Time Mode.....	113
4.7.3	Timemark.....	114

- 4.8 Receiver Configuration ..... 115
  - 4.8.1 Configuration Concept..... 115
  - 4.8.2 GPSMODE Pin Configuration (ROM only / Low Cost Receivers)..... 118
- 4.9 System Functions ..... 121
  - 4.9.1 Reset Options..... 121
  - 4.9.2 RESET\_N - Reset signal generation and use..... 121
  - 4.9.3 BOOT\_INT– Boot Mode Selection ..... 122
  - 4.9.4 EXTINT - External Interrupt Pin..... 122
  - 4.9.5 System Monitoring ..... 123
- 4.10 Dead Reckoning enabled GPS module (DR module)..... 123
- 5 Product Handling..... 124**
  - 5.1 Packaging..... 124
    - 5.1.1 Reels ..... 124
    - 5.1.2 Tapes ..... 125
  - 5.2 Shipment, Storage and Handling **A4** ..... 125
    - 5.2.1 Handling ..... 125
    - 5.2.2 Shipment **A4** ..... 125
    - 5.2.3 Storage ..... 126
    - 5.2.4 Handling ..... 126
    - 5.2.5 Floor Life ..... 127
  - 5.3 Processing **A4** ..... 128
    - 5.3.1 Moisture Preconditioning ..... 128
    - 5.3.2 Soldering Paste **A4** ..... 128
    - 5.3.3 Reflow Soldering **A4** ..... 129
    - 5.3.4 Optical Inspection..... 130
    - 5.3.5 Cleaning..... 131
    - 5.3.6 Repeated Reflow Soldering..... 131
    - 5.3.7 Wave Soldering ..... 131
    - 5.3.8 Hand Soldering ..... 131
    - 5.3.9 Rework..... 131
    - 5.3.10 Conformal Coating ..... 132
    - 5.3.11 Casting..... 132
    - 5.3.12 Grounding Metal Covers ..... 132
    - 5.3.13 Use of any Ultrasonic Processes ..... 132
- 6 Product Testing..... 133**
  - 6.1 u-blox In-Series Production Test **A4** ..... 133



- 6.2 Test Parameters for OEM Manufacturer ..... 133
- 6.3 System Sensitivity Test ..... 134
  - 6.3.1 Guidelines for Sensitivity Tests ..... 134
  - 6.3.2 'Go/No go' tests for integrated devices ..... 134
- 7 PC Support Tools ..... 135**
  - 7.1 Firmware Update A4 ..... 135
    - 7.1.1 ATR062xL.exe A4 ..... 135
    - 7.1.2 U-center Update Tool A4 ..... 136
    - 7.1.3 Firmware update with u-center AE ..... 136
  - 7.2 Using u-center ANTARIS® Edition ..... 138
    - 7.2.1 Using u-center Message View ..... 139
    - 7.2.2 Recording Logfiles ..... 141
    - 7.2.3 Firmware Upgrade with U-center ..... 141
    - 7.2.4 Configuration of ANTARIS®4 based GPS Receivers ..... 142
- 8 Troubleshooting ..... 144**
- A Default Settings ..... 147**
  - A.1 Hardware ..... 147
  - A.2 Navigation ..... 147
  - A.3 Power Saving Modes ..... 149
  - A.4 SBAS Configuration ..... 150
  - A.5 Communications Interface A4 ..... 150
  - A.6 Messages (UBX – CFG – MSG) A4 ..... 151
  - A.7 Messages (UBX – CFG – INF) A4 ..... 152
  - A.8 Timing Settings ..... 153
- B Map Datums ..... 154**
  - B.1 Predefined Datums ..... 154
- C Demo Design ..... 162**
  - C.1 TIM - GPS standalone Receiver ..... 162
    - C.1.1 Schematic ..... 162
    - C.1.2 Bill of Material ..... 162
    - C.1.3 Layout ..... 162
  - C.2 LEA – Smart Antenna A4 ..... 163
    - C.2.1 Schematic ..... 164
    - C.2.2 Bill of Material ..... 165

C.2.3	Layout .....	166
<b>D</b>	<b>Migration to ANTARIS® 4 receivers <span style="background-color: #90EE90; border-radius: 50%; padding: 0 2px;">A4</span> .....</b>	<b>167</b>
D.1	Software Changes .....	167
D.2	Migration from LEA-LA to LEA-4A/LEA-4S .....	167
D.3	Migration from LEA-LA to LEA-4H/LEA-4P .....	168
D.4	Migration from TIM-Lx to TIM-4x pin out.....	170
D.5	Pin Comparison ANTARIS® to ANTARIS® 4.....	171
D.6	Migration from TIM-ST to TIM-4x <span style="background-color: #90EE90; border-radius: 50%; padding: 0 2px;">A4</span> .....	173
<b>E</b>	<b>Mechanical Dimensions/ Pinout <span style="background-color: #90EE90; border-radius: 50%; padding: 0 2px;">A4</span> .....</b>	<b>175</b>
E.1	LEA Modules .....	175
E.2	TIM Modules .....	176
E.3	NEO Modules .....	177
<b>F</b>	<b>Index .....</b>	<b>178</b>
<b>G</b>	<b>Lists .....</b>	<b>180</b>
G.1	List of Figures .....	180
G.2	List of Tables.....	182
<b>H</b>	<b>Glossary .....</b>	<b>185</b>

# 1 GPS Fundamentals

## 1.1 Theory of operation

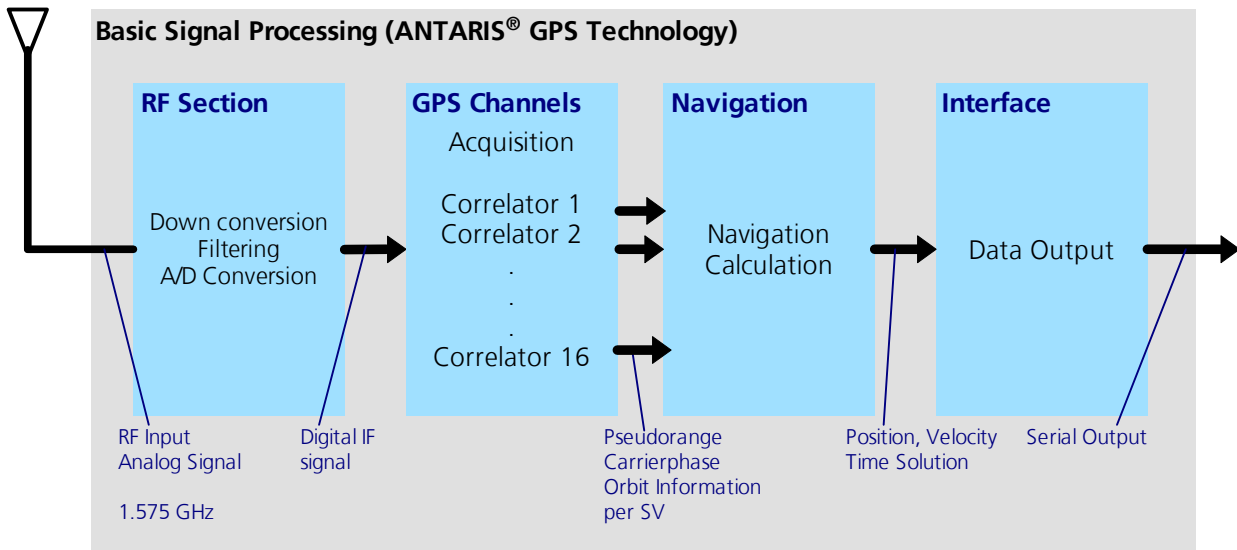

**Figure 1: Basic Signal Processing**

The ANTARIS®4 GPS receiver is an L1 Frequency (C/A Code) GPS receiver and performs the entire GPS signal processing, from antenna input to serial position data output.

The processing steps involved are:

1. **RF Section**  
In the RF Section the GPS signal received by the antenna is amplified, filtered and converted to an intermediate frequency (IF). An A/D converter changes the analog intermediate frequency into a digital IF signal.
2. **GPS Channels**  
The digital IF signal bit stream is passed to the baseband section, where it is fed into the correlators. It is the function of the correlators to acquire and track the satellite signals. There are 16 channels used in parallel, with each correlator looking for a characteristic PRN code sequence in the bit stream. Once the correlator has identified a valid signal, Pseudorange, Carrier Phase and Orbit Information can be extracted from the GPS signal.
3. **Navigation**  
The on-board processor runs an algorithm that calculates the position, velocity and time. This calculation is called the navigation solution. Once the navigation solution is calculated, it can be transformed into the desired coordinate system, e.g. Latitude/ Longitude/ Altitude.
4. **Interface**  
The data of the navigation solution is available at the serial RS232 or USB interface.

## 1.2 Basic Operation Cycle

When the receiver is powered up, it proceeds through a sequence of states until it can initially determine position, velocity and time. Afterwards, the satellite signals are tracked continuously and the position is calculated periodically.

This process is depicted below:

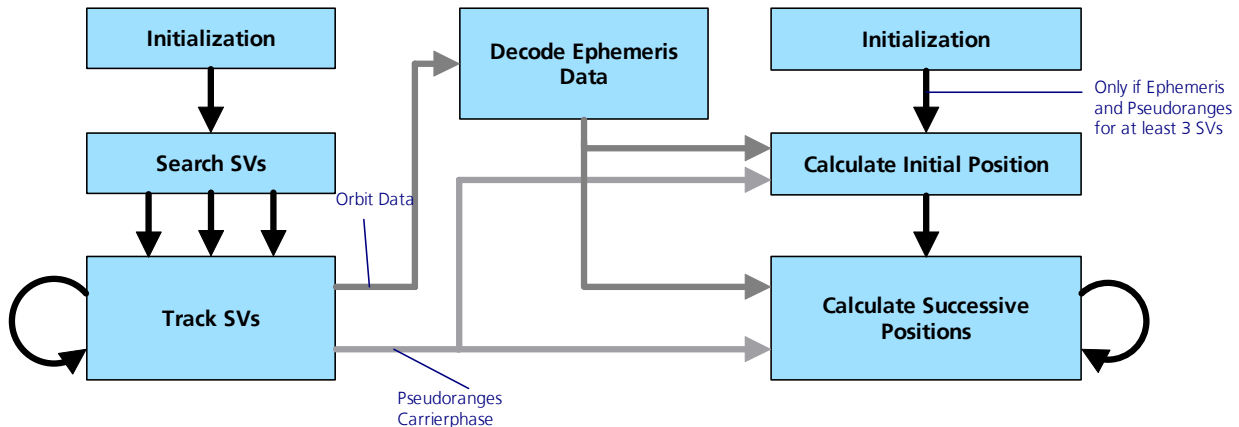

Figure 2: Basic Operation Cycle

In order to perform a navigation solution (3D solution), the receiver needs

- Distances (Pseudo Ranges) for at least 4 SVs (Space Vehicles)
- Ephemeris Data for the SVs it will use in the navigation solution.

**Note** If almanac navigation is enabled, the receiver can calculate a position without downloading ephemeris data (with a significant position error compared to an ephemeris based solution).

The initial position calculation is made using a Least-Squares Algorithm. Successive position calculations are performed with a Kalman Filter. To generate a Position (3D solution) Calculation the receiver needs at least 4 measurements to different satellites, to calculate a position (Lat/Long/Height), for a 2D solution with an estimated altitude 3 different satellites are required.

Pseudo Range and Carrier Phase information is available to the Position Determination Algorithms if the receiver has found a SV (Acquisition) and can track the signal thereafter.

Ephemeris data for a SV can be decoded from Orbit Data once the GPS signal has been acquired. Each SV transmits its own ephemeris data, the transmission lasts for 18 seconds, repeating every 30 seconds.

The receiver stores ephemeris data in battery-backup memory. This data is valid for 2 hours and can be used in future startup's to improve the time to first fix (TTFF). Ephemeris can also be supplied to the receiver via the serial port.

## 1.3 Start-Up

Depending on the availability of last position, current time and ephemeris data, the receiver will apply different strategies to start-up, namely:

### Coldstart

In Coldstart the receiver has no information of its last position or time. This is the case when the RTC has not been running or when no valid ephemeris or almanac data is available. Such a situation is when the receiver has never navigated or the battery backup memory is lost.

### Warmstart

Warmstart is performed whenever the receiver has only access to valid almanac data, and has not significantly moved since the last valid position calculation. This is typically the case, if the receiver has been shut off for more than 2 hours, but still has knowledge of last position, time and almanac. This allows it to predict the current visible SVs. However, since ephemeris data is not available or outdated, the receiver needs to wait for the ephemeris broadcast to complete.

### Hotstart

Hotstart is performed whenever the receiver still has access to valid ephemeris data and precise time. This is typically the case if the receiver has been shut off for less than 2 hours and the RTC has been running during that time. Furthermore, during the previous session, the receiver must have been navigating (to allow it to decode and store ephemeris data).

In Hotstart, the receiver can predict the currently visible SVs, and is therefore able to quickly acquire and track the signal. Because ephemeris is already known, there is no need to wait for the ephemeris broadcast to complete.

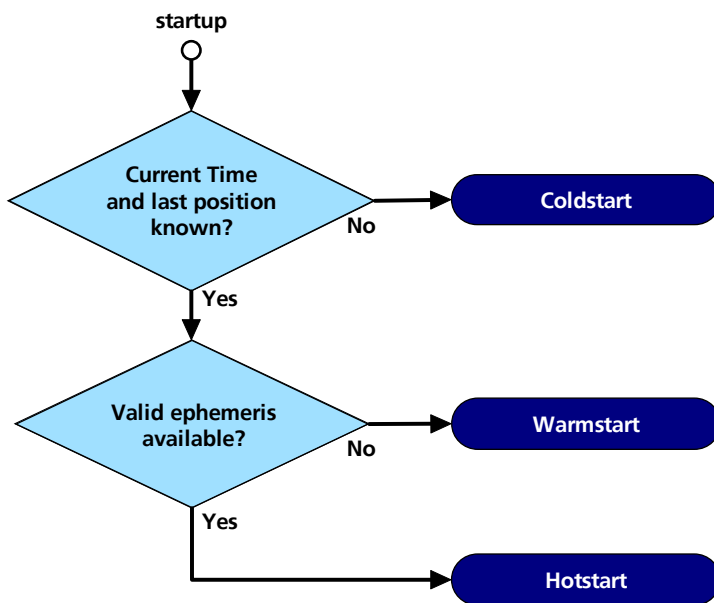

Figure 3: Decision Tree on Startup Mode

If external aiding information like ephemeris and/or precise position and time are provided to the receiver, the Time To First Fix can be significantly improved. Refer to *Section 4.5.4* for further information.

## 1.4 Considerations for GPS Performance

GPS works with weak signals. The signal strength on earth is approximately 15dB below the thermal noise floor. In order to design a reliable GPS system, the following parameters have to be considered carefully during the design phase as they may significantly degrade the GPS performance.

1. Antenna limitations
  - Poor gain of the GPS antenna
  - Poor directivity (radiation pattern) of the GPS antenna
  - Improper orientation of the antenna to the sky
  - Poor matching between antenna and cable impedance
  - Poor noise performance of the receivers input stage or the antenna amplifier
2. Electrical Environment
  - Jamming from external signals
  - Jamming from signals generated by the receiver itself
3. GPS related effects
  - Signal path obstruction by buildings, foliage, covers, snow, etc.
  - Multi-path effects
  - Satellite constellation and geometry

The antenna related issues from the above list will be further discussed in *Section 1.5*. Jamming and interference issues will be extensively discussed in *Section 1.6*.

### 1.4.1 Dilution of Precision (DOP)

The Dilution of Precision (DOP) is a unit less value that indicates when the satellite geometry provides the most accurate results. It is the mathematical representation of the quality of the navigation solution, based on the geometry of the satellites used in the calculation. The number of visible satellites and their relative positions in the sky mainly control DOP. Satellites spread over the sky give better results (lower DOP).

The most commonly used DOP is position dilution of precision (PDOP), which is the combination of horizontal dilution of precision (HDOP) and vertical dilution of precision (VDOP). A PDOP value of 1 indicates an optimum satellite constellation and high-quality data. The quality of the data decreases as the PDOP value increases. PDOP values in excess of 8 are considered poor.

 **Note** A point calculated with a PDOP of 30.0 can deviate by more than 150 m from its true location.

**Examples of DOP values:**

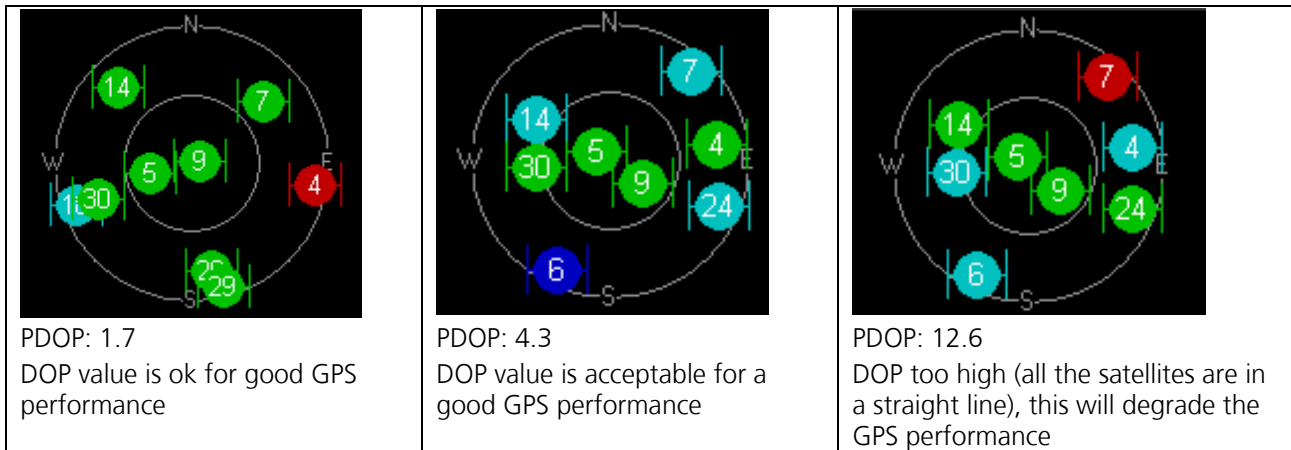

**Figure 4: Examples of DOP values**

**1.4.2 Multipath**

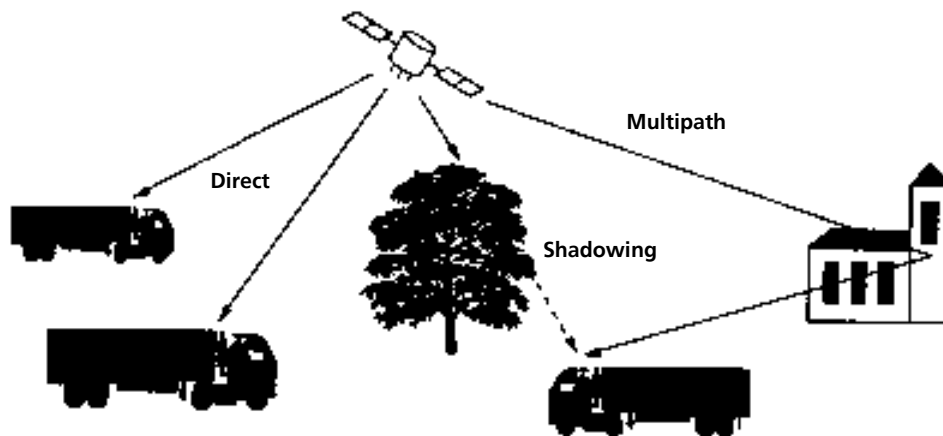

**Figure 5: A multi-path environment**

A multi-path environment exists if GPS signals arrive at the antenna directly from the satellite, (line of sight, LOS) and also from reflective surfaces, e.g. water or building walls. If there is a direct path in addition to the reflected path available, the receiver can usually detect the situation and compensate to some extent. If there is no direct line of sight, but only reflections, the receiver is not able to detect the situation. Under these multipath conditions the range measurement to the satellite will provide incorrect information to the navigation solution, resulting in a less accurate position. If there are only a few satellites in sight, the navigation solution might be wrong by several hundred meters.

If there is a LOS available, the effect of multi-path is actually twofold. First, the correlation peak will be distorted which results in a less precise position. This effect can be compensated for by advanced receiver technology such as the ANTARIS<sup>®</sup>4 t patented multipath mitigation scheme. The second effect relates to the carrier phase relation of the direct and reflected signal, the received signal strength is subject to an interference effect. The two signals may cancel each other (out of phase) or add to each other (in phase). Even if the receiver remains stationary, the motion of the satellite will change the phase relation between direct and reflected signal, resulting in a periodic modulation of the C/N<sub>0</sub> measured by the receiver.

The receiver cannot compensate for the second effect because the signals cancel out at the antenna, not inside the GPS unit. However, as the reflected signal is usually much weaker than the direct signal, the two signals will not cancel out completely. The reflected signal will also have an inverted polarity (left hand circular rather than right hand circular), further reducing the signal level, particularly if the antenna has good polarization selectivity.

Water is a very good reflector; so all marine applications require special attention to reflected signals arriving at the antenna from the underside, i.e. the water surface. Also, the location of the antenna close to vertical metal surfaces can be very disruptive since metal is an almost perfect reflector. When mounting an antenna on top of a reflective surface, the antenna should be mounted as close to the surface as possible. Then, the reflective surface will act as an extension of the antennas ground plane and not as a source of multi-path.

## 1.5 Antennas

Even the best receiver cannot bring back what has been lost at the antenna. The importance of the attention paid to this part of a GPS system cannot be stated highly enough.

### 1.5.1 Selecting the right Antenna

Several different antenna designs are available on the GPS applications market. The GPS signal is right-hand circular polarized (RHCP). This results in a style of antenna that is different from the well-known whip antennas used for linear polarized signals. The most prominent antenna designs for GPS are the patch antenna as shown in *Figure 6*.

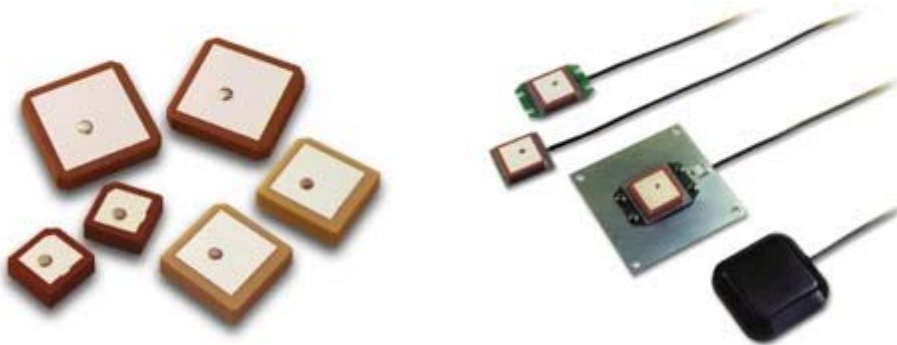

**Figure 6: Patch Antennas, EMTAC Technology Corp.**

Another style is the quadrifilar helix antenna shown in *Figure 7*. The actual geometric size of both antenna designs depends on the dielectric that fills the space between the active parts of the antenna. If the antenna is only loaded with air it will be comparatively large, high dielectric constant ceramics result in a much smaller form factor. The smaller the dimensions of the antenna, the more performance critical tight manufacturing tolerances become. Furthermore, a smaller antenna will present a smaller aperture to collect the signal energy from sky resulting in a lower overall gain of the antenna. This is the result of pure physics and there is no “magic” to get around this problem. Amplifying the signal after the antenna will not improve the signal to noise ratio.



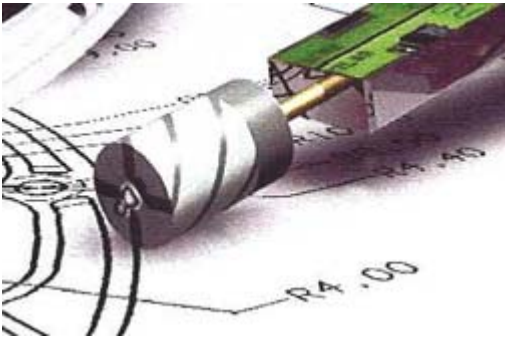

**Figure 7: Quadrifilar Helix Antenna, Sarantel, Ltd.**

In contrast to helix antennas, patch antennas require a ground plane for operation. Helix antennas can be designed for use with or without a ground plane.

For precision applications such as surveying or timing, some very high-end systems do exist. Common to these designs are large size, high power consumption and high cost. These designs are highly optimized to suppress multi-path signals reflected from the ground (choke ring antennas, multi-path limiting antennas, MLA). Another area of optimization is accurate determination of the phase center of the antenna. For precision GPS applications with position resolution in the millimeter range it is important that signals from satellites at all elevations virtually meet at exactly the same point inside the antenna. For these types of applications receivers with multiple antenna inputs are often required.

At the low end of the spectrum of possible antenna solutions - if the user is willing to accept significant signal losses - a simple linear polarized whip or strip antenna will work. Compared to a circular polarized antenna, a minimum of 3 dB of signal to noise ratio will be lost.

### **1.5.2 Active and Passive Antennas**

Passive antennas contain only the radiating element, e.g. the ceramic patch or the helix structure. Sometimes they also contain a passive matching network to match the electrical connection to 50 Ohms impedance.

Active antennas have an integrated low-noise amplifier. This is beneficial in two respects. Firstly, the losses of the cable no longer affect the overall noise figure of the GPS receiver system. Secondly, the receiver noise figure can be much higher without sacrificing performance. Therefore, some receivers will only work with active antennas. Active antennas require a power supply that contributes to total GPS system power consumption, typically in the region of 5 to 20 mA. Usually, the supply voltage is fed to the antenna through the coaxial RF cable. Inside the antenna, the DC component on the inner conductor will be separated from the RF signal and routed to the supply pin of the LNA.

The use of an active antenna is always advisable if the RF-cable length between receiver and antenna exceeds approximately 10 cm. Care should be taken that the gain of the LNA inside the antenna does not lead to an overload condition at the receiver. For receivers that also work with passive antennas, an antenna LNA gain of 15 dB is usually sufficient, even for cable lengths up to 5 m. There's no need for the antenna LNA gain to exceed 26 dB for use with u-blox receivers. With shorter cables and a gain above 25 dB, an overload condition might occur on some receivers.

When comparing gain measures of active and passive antennas one has to keep in mind that the gain of an active antenna is composed of two components, the antenna gain of the passive radiator, given in dBic, and the LNA power gain given in dB. A low antenna gain cannot be compensated by high LNA gain. If a manufacturer provides one total gain figure, this is not sufficient to judge the quality of the antenna. One would need information on antenna gain (in dBic), amplifier gain, and amplifier noise figure.

### **1.5.3 Patch Antennas**

Patch antennas are ideal for an application where the antenna sits on a flat surface, e.g. the roof of a car. Patch antennas can demonstrate a very high gain, especially if they are mounted on top of a large ground plane. Ceramic patch antennas are very popular because of their small size, typically measuring 25 x 25 mm<sup>2</sup> down to

12 x 12 mm<sup>2</sup>. Very cheap construction techniques might use ordinary circuit board material like FR-4 or even air as a dielectric, but this will result in a much larger size, typically in the order of 10 x 10 cm<sup>2</sup>. *Figure 8* shows a typical example of the radiation pattern of a 16 x 16 mm<sup>2</sup> ceramic patch antenna. This measurement only shows the upper sphere of the radiation pattern. Depending on ground plane size there will also be a prominent back lobe present.

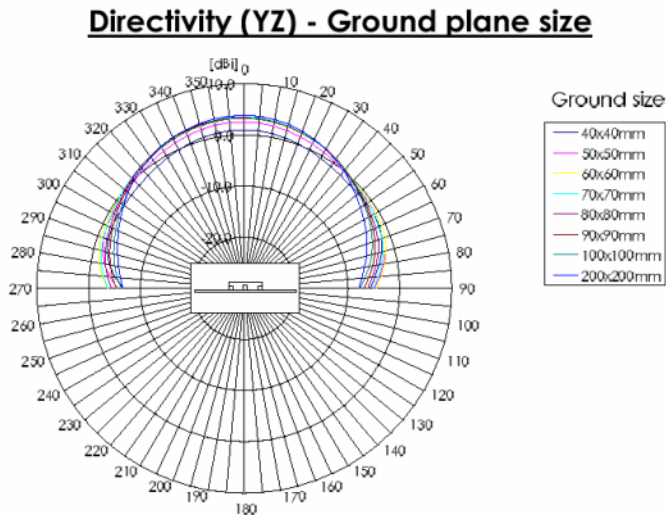

**Figure 8: Typical Radiation Pattern of a Patch Antenna, MuRata, Inc.**

For the specific example shown in *Figure 9* one can easily see that the so-called axial ratio, the relation of major to minor axis of the elliptical polarization has a minimum at the 50 mm<sup>2</sup> square ground plane. At this point, the polarization of the antenna is closest to an ideal circular polarization (axial ratio = 0 dB). At a 100 mm<sup>2</sup> square ground plane size this particular patch shows an axial ratio in the order of 10 dB, which is closer to linear polarization than to circular and will result in respective losses. This effect can also be seen in the left graph of the figure, where gain no longer increases with increasing ground plane size. In conclusion, the correct dimensions for the size of the ground plane can serve as a useful compromise between maximum gain and reasonable polarization loss.

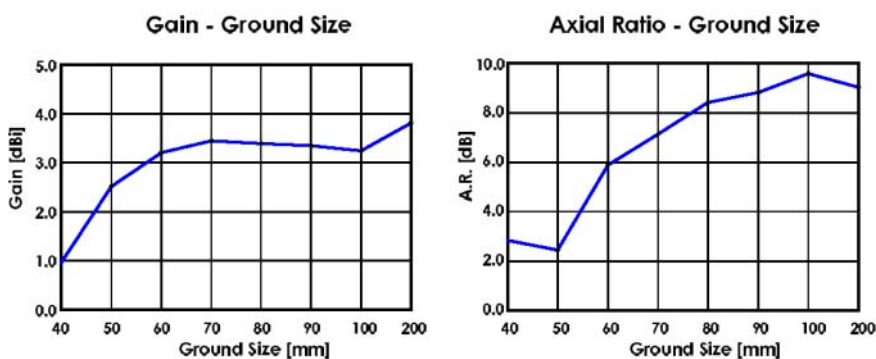

**Figure 9: Typical Gain and Axial Ratio of a Patch antenna with respect to ground plane size, MuRata, Inc.**

A good allowance for ground plane size is typically in the area of 50 to 70 mm<sup>2</sup>. This number is largely independent of the size of the patch itself (when considering ceramic patches). Patch antennas with small ground planes will also have a certain back-lobe in their radiation pattern, making them susceptible to radiation coming from the backside of the antenna, e.g. multi-path signals reflected off the ground. The larger the size of the ground plane, the less severe this effect becomes.

Smaller sized patches will usually reach their maximum gain with a slightly smaller ground plane compared to a larger size patch. However, the maximum gain of a small sized patch with optimum ground plane may still be much lower than the gain of a large size patch on a less than optimal ground plane.

It is not only gain and axial ratio of the patch antenna that is affected by the size of the ground plane but also the matching of the antenna to the 50 Ohms impedance of the receiver. See *Section 1.5.8* for more information on matching.

### 1.5.4 Helix Antennas

Helix antennas can be designed for use with or without ground plane. For example, the radiating elements on board the GPS satellites have a ground plane. Using an array of helix antennas, the GPS satellites can control the direction of the emitted beam. If a helix antenna is designed without ground plane it can be tuned such to show a more omni directional radiation pattern as shown in *Figure 10*.

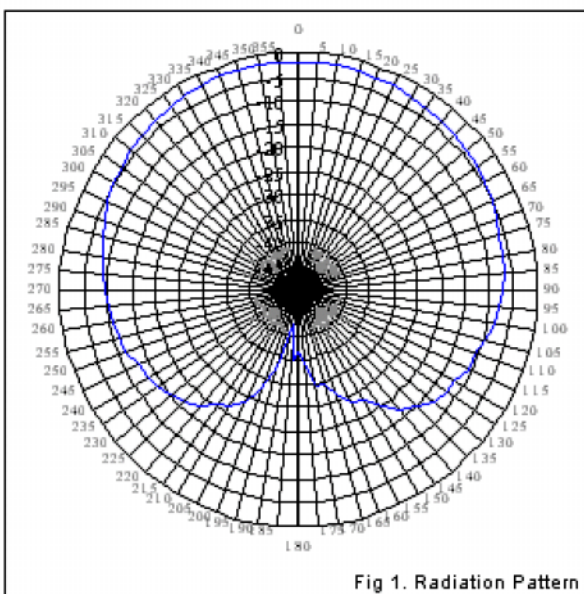

**Figure 10: Radiation pattern of helix antenna without ground plane, Sarantel, Ltd.**

Although we can determine an axial ratio close to 9 dB between zero degree and 90 degrees elevation, which compares to the patch antenna, the back lobe of the helix generally degrades much smoother and does not show any sensitivity at the  $-180$  degree direction. In contrast, the back lobe of a patch antenna depends very much on size and shape of the ground plane. As with patch antennas, filling the antenna with a material with a high dielectric constant can reduce the size of helix antennas. Sizes in the order of 18 mm length and 10 mm diameter are being offered on the market. Again, antenna gain will decrease with decreased size.

### 1.5.7 Helix or Patch, which selection is best?

For practical applications the possibilities of integrating a certain style of antenna into the actual device is of primary concern. Some designs naturally prefer the patch type of antenna, e.g. for rooftop applications. Others prefer the pole like style of the helix antenna, which is quite similar to the style of antennas used in mobile phones. Furthermore, it is important that the antenna's main lobe points to the sky in order to receive as many satellites as possible with maximum gain. If the application is a hand held device, the antenna should be designed in such a way that natural user operation results in optimum antenna orientation. The helix antenna seems to be more appropriate in this respect.

However, one has to keep in mind that comparable antenna gain requires comparable size of the antenna aperture, which will lead to a larger volume filled by a helix antenna in comparison to a patch antenna. Helix

antennas with a “reasonable” size will therefore typically show a lower sensitivity compared to a “reasonably” sized patch antenna.

A helix antenna might result in a “more satellites on the screen” situation in difficult signal environments when directly compared with a patch antenna. This is due to the fact that the helix will more easily pick up signals through its omni directional radiation pattern. However, the practical use of these signals is very limited because of the uncertain path of the reflected signals. Therefore, the receivers can see more satellites but the navigation solution will be degraded because of distorted range measurements in a multi-path environment.

If possible test the actual performance of different antenna types in a real life environment before starting the mechanical design of the GPS enabled product.

### 1.5.8 Antenna Matching

All common GPS antennas are designed for a 50 Ohms electrical load. Therefore, one should select a 50 Ohms cable to connect the antenna to the receiver. However, there are several circumstances under which the matching impedance of the antenna might shift considerably. Expressed in other words, this means that the antenna no longer presents a 50 Ohms source impedance. Typically what happens is that the center frequency of the antenna is shifted away from GPS frequency - usually towards lower frequencies – by some external influence. The reasons for this effect are primarily disturbances in the near field of the antenna. This can either be a ground plane, that does not have the size for which the antenna was designed , or it can be an enclosure with a different dielectric constant than air.

In order to analyze effects like this one would normally employ electrical field simulations, which will result in exact representation of the electric fields in the near field of the antenna. Furthermore, these distortions of the near field will also show their effect in the far field, changing the radiation pattern of the antenna. Unfortunately, there is no simple formula to calculate the frequency shift of a given antenna in any specified environment. So one must do either extensive simulation or experimental work. Usually, antenna manufacturers offer a selection of pre-tuned antennas, so the user can test and select the version that best fits the given environment. However, testing equipment such as a scalar network analyzer is needed to verify the matching.

Again, it must be pointed out that the smaller the size of the antenna, the more sensitive it will be to distortions in the near field. Also the antenna bandwidth will decrease with decreasing antenna size, making it harder to achieve optimum tuning.

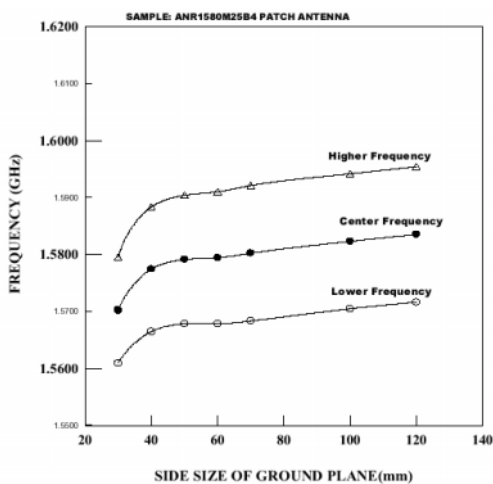

Figure 11: Dependency of center frequency on ground plane dimension for a 25 x 25 mm<sup>2</sup> patch, EMTAC

A LNA placed very close to the antenna can help to relieve the matching requirements. If the interconnect length between antenna and LNA is much shorter than the wavelength (9.5 cm on FR-4), the matching losses become less important. Under these conditions the matching of the input to the LNA becomes more important. Within a reasonable mismatch range, integrated LNAs can show a gain decrease in the order of a few dBs versus an increase of noise figure in the order of several tenths of a dB. If your application requires a very small antenna, a

LNA can help to match the hard to control impedance of the antenna to a 50 Ohms cable. This effect is indeed beneficial if the antenna cable between the antenna and the receiver is only short. In this case, there's no need for the gain of the LNA to exceed 10-15 dB. In this environment the sole purpose of the LNA is to provide impedance matching and not signal amplification.

### 1.5.9 Antenna Placement

Where the antenna is mounted is crucial for optimal performance of the GPS receiver.

When using patch antennas, the antenna plane should be parallel to the geographic horizon. The antenna must have full view of the sky ensuring a direct line-of-sight with as many visible satellites as possible.

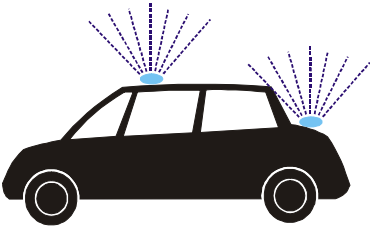
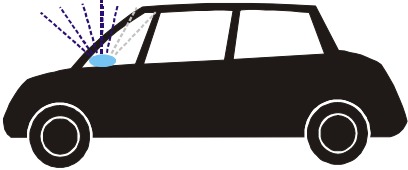
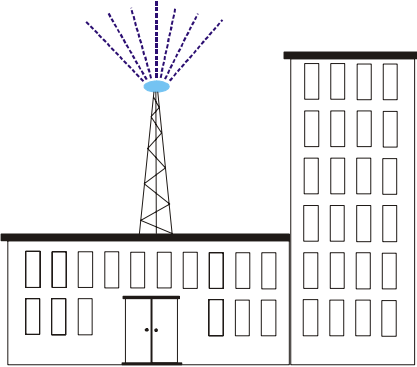
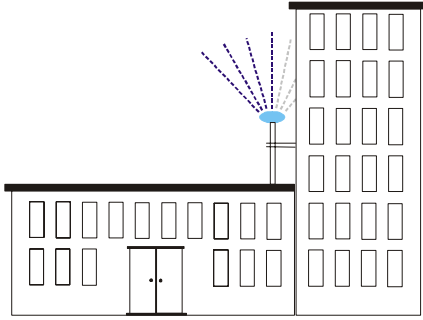
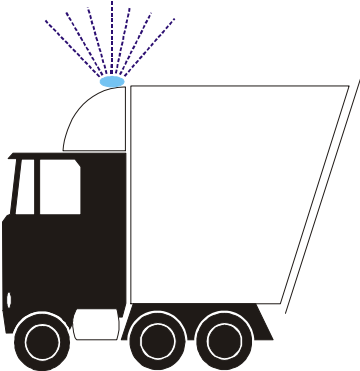
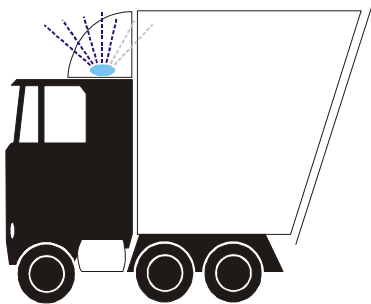
1 <sup>st</sup> Choice Placement	2 <sup>nd</sup> Choice Placement
Recommended Antenna positions	Performance may be degraded! If recommended placements are not available, these may also viable.
	 <p><b>Note:</b> Window and roof reduce GPS signal and obstruct sky view<sup>1</sup></p>
	 <p><b>Note:</b> There may be multipath signals and a obstructed sky view</p>
	 <p><b>Note:</b> Fiberglass airfoil attenuates the GPS signal</p>

**Table 1: Optimal antenna placement**

<sup>1</sup> Some cars have a metallic coating on the windscreens. GPS reception may not be possible in such a car without the use of SuperSense® Technology. There is usually a small section, typically behind the rear view mirror, reserved for mobile phone and GPS antennas.

## 1.6 Interference Issues

A typical GPS receiver has a very low dynamic range. This is because the antenna should only detect thermal noise in the GPS frequency band, given that the peak power of the GPS signal is 15 dB below the thermal noise floor. This thermal noise floor is usually very constant over time. Most receiver architectures use an automatic gain control (AGC) circuitry to automatically adjust to the input levels presented by different antenna and pre-amplifier combinations. The control range of these AGC's can be as large as 50 dB. However, the dynamic range for a jamming signal exceeding the thermal noise floor is typically only 6 to 12dB, due to the one or two bit quantization schemes commonly used in GPS receivers. If there are jamming signals present at the antenna and the levels of these signals exceed the thermal noise power, the AGC will regulate the jamming signal, suppressing the GPS signal buried in thermal noise even further. Depending on the filter characteristics of the antenna and the front end of the GPS receiver, the sensitivity to such in-band jamming signals decreases more or less rapidly if the frequency of the jamming signal moves away from GPS signal frequency. We can conclude that a jamming signal exceeding thermal noise floor within a reasonable bandwidth (e.g. 100 MHz) around GPS signal frequency will degrade the performance significantly.

Even out-of-band signals can affect GPS receiver performance. If these jamming signals are strong enough that even antenna and front-end filter attenuation are not sufficient, the AGC will still regulate the jamming signal. Moreover, very high jamming signal levels can result in non-linear effects in the pre-amplifier stages of the receiver, resulting in desensitizing of the whole receiver. One such particularly difficult scenario is the transmitting antenna of a DCS handset (max. 30 dBm at 1710 MHz) in close proximity to the GPS antenna. When integrating GPS with other RF transmitters special care is necessary.

If the particular application requires integration of the antenna with other digital systems, one should make sure that jamming signal levels are kept to an absolute minimum. Even harmonics of a CPU clock can reach as high as 1.5 GHz and still exceed thermal noise floor.

On the receiver side there's not much that can be done to improve the situation without significant effort. Of course, high price military receivers have integrated counter-measures against intentional jamming. But the methods employed are out of the scope of this document and might even conflict with export restrictions for dual-use goods.

The recommendations and concepts in this section are completely dependent on the specific applications. In situations where an active antenna is used in a remote position, e.g. >1 m away from other electronics, interference should not be an issue.

**Note** If antenna and electronics are to be integrated tightly, the following sections should be read very carefully.

### 1.6.1 Sources of Noise

Basically two sources are responsible for most of the interference with GPS receivers:

1. Strong RF transmitters close to GPS frequency, e.g. DCS at 1710 MHz or radars at 1300 MHz.
2. Harmonics of the clock frequency emitted from digital circuitry.

The first problem can be very difficult to solve, but if GPS and RF transmitter are to be integrated close to each other, there's a good chance that there is an engineer at hand who knows the specifications of the RF transmitter. In most cases, counter measures such as filters will be required for the transmitter to limit disruptive emissions below the noise floor near the GPS frequency.

Even if the transmitter is quiet in the GPS band, a very strong emission close to it can cause saturation in the front-end of the receiver. Typically, the receiver's front-end stage will reach its compression point, which will in turn increase the overall noise figure of the receiver. In that case, only special filtering between the GPS antenna and receiver input will help to reduce signal levels to the level of linear operation at the front-end.

The second problem is more common but also regularly proves to be hard to solve. Here, the emitting source is not well specified and the emission can be of broadband nature, making specific countermeasures very difficult.

Moreover, the GPS band is far beyond the 1 GHz limit that applies to almost all EMC regulations. So, even if a device is compliant with respect to EMC regulations it might severely disturb a GPS receiver.

If the GPS antenna is to be placed very close to some other electronics, e.g. the GPS receiver itself or a PDA-like appliance, the EMC issue must be taken very seriously right from the concept phase of the design. It is one of the most demanding tasks in electrical engineering to design a system that is essentially free of measurable emissions in a given frequency band.

## 1.6.2 Eliminating Digital Noise Sources

Digital noise is caused by short rise-times of digital signals. Data and address buses with rise-times in the nanosecond range will emit harmonics up to several GHz. The following sections contain some general hints on how to decrease the level of noise emitted from digital circuit board that are potentially in close proximity to the GPS receiver or the antenna.

### 1.6.2.1 Power and Ground Planes

Use solid planes for power and ground interconnect. This will typically result in a PCB with at least four layers but will also result in a much lower radiation. Solid ground planes ensure that there is a defined return path for the signals routed on the signal layer. This will reduce the “antenna” area of the radiating loop. Planes should be solid in a sense that there are no slots or large holes inside the plane.

The outer extent of the power plane should be within the extent of the ground plane. This avoids that the edges of the two planes form a slot antenna at the board edges. It’s a good idea to have a ground frame on the circumference of every layer that is connected to the ground plane with as many vias as possible. If necessary, a shield can then be easily mounted on top of this frame (see *Figure 12*). Furthermore, free space on the outermost Layers can be filled with ground shapes connected to the ground plane to shield radiation from internal layers.

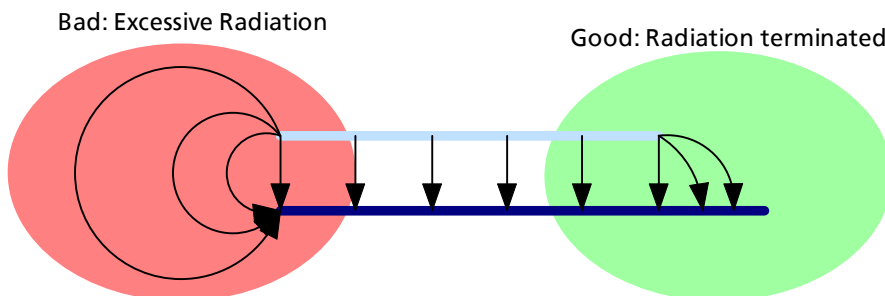

Figure 12: Signal and power plane extends should lie within ground plane extends

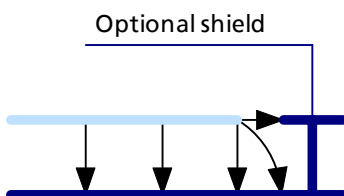

Figure 13: Further improvement of reduction of power plane radiation

### 1.6.2.2 High Speed Signal Lines

Keep high-speed lines as short as possible. This will reduce the area of the noise-emitting antenna, i.e. the conductor traces. Furthermore, the use of line drivers with controlled signal rise-time is suggested whenever

driving large bus systems. Alternatively, high-speed signal lines can be terminated with resistors or even active terminations to reduce high frequency radiation originating from overshoot and ringing on these lines.

If dielectric layers are thick compared to the line width, route ground traces between the signal lines to increase shielding. This is especially important if only two layer boards are used (see *Figure 14*).

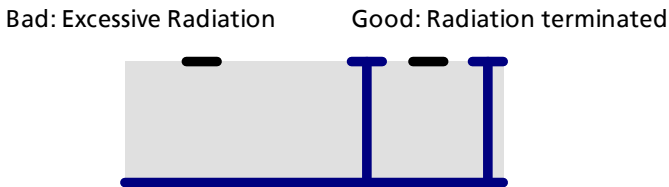

**Figure 14: Terminating radiation of signal lines**

### 1.6.2.3 Decoupling Capacitors

Use a sufficient number of decoupling capacitors in parallel between power and ground nets. Small size, small capacitance types reduce high-frequency emissions. Large size, high capacitance types stabilize low frequency variations. It's preferred to have a large number of small value capacitors in parallel rather than having a small number of large value capacitors. Every capacitor has an internal inductance in series with the specified capacitance. In addition to resonance, the capacitor will also behave like an inductor. If many capacitors are connected in parallel, total inductance will decrease while total capacitance will increase. *Figure 15* shows the impedance dependence of SMD capacitors.

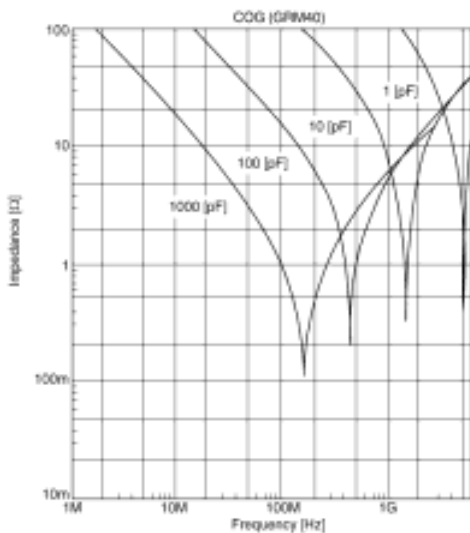

**Figure 15: Impedance of 0805 size SMD capacitors vs. frequency, MuRata**

If the power and ground plane are not connected by an efficient capacitor network, the power plane may act as a radiating patch antenna with respect to the ground. Furthermore, ceramic capacitors come with different dielectric materials. These materials show different temperature behavior. For industrial temperature range applications, at least a X5R quality should be selected. Y5V or Z5U types may lose almost all of their capacitance at extreme temperatures, resulting in potential system failure at low temperatures because of excessive noise emissions from the digital part. Tantalum capacitors show good thermal stability, however, their high ESR (equivalent series resistance) limits the usable frequency range to some 100 kHz.



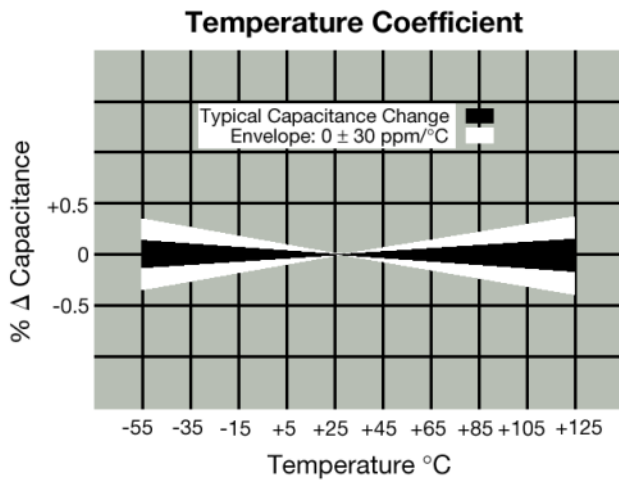

Figure 16: Temperature dependency of COG/NPO dielectric, AVX

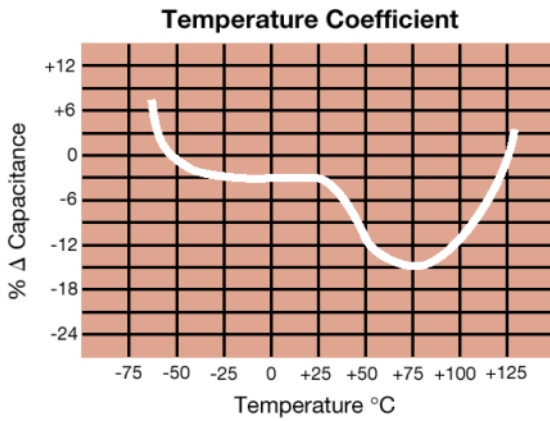

Figure 17: Temperature dependency of X7R dielectric, AVX

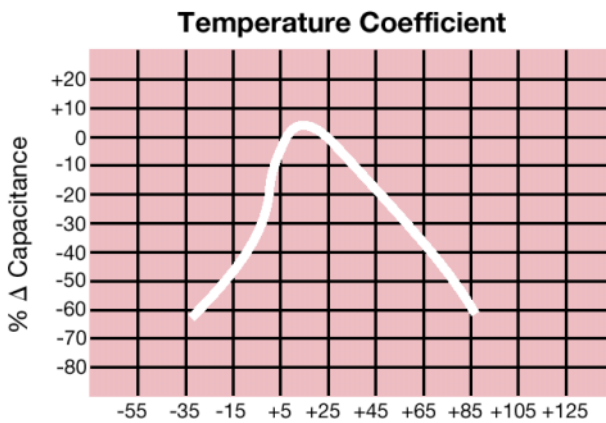

Figure 18: Temperature dependency of Y5V dielectric, AVX

### 1.6.3 Shielding

If employing the countermeasures listed in *Section 1.6.2* cannot solve EMI problems, the solution may be shielding of the noise source. In the real world, shields are not perfect. The shielding effectiveness you can expect from a solid metal shield is somewhere in the order of 30-40 dB. If a thin PCB copper layer is used as a shield, these values can be even lower. Perforation of the shield will also lower its effectiveness.

Be aware of the negative effects that holes in the shield can have on shielding effectiveness. Lengthy slots might even turn a shield into a radiating slot antenna. Therefore, a proper shield has to be tightly closed and very well connected to the circuit board.

#### 1.6.3.1 Feed through Capacitors

The basic concept of shielding is that a metal box will terminate all electrical fields on its surface. In practice we have the problem that we need to route some signals from inside to outside of this box.

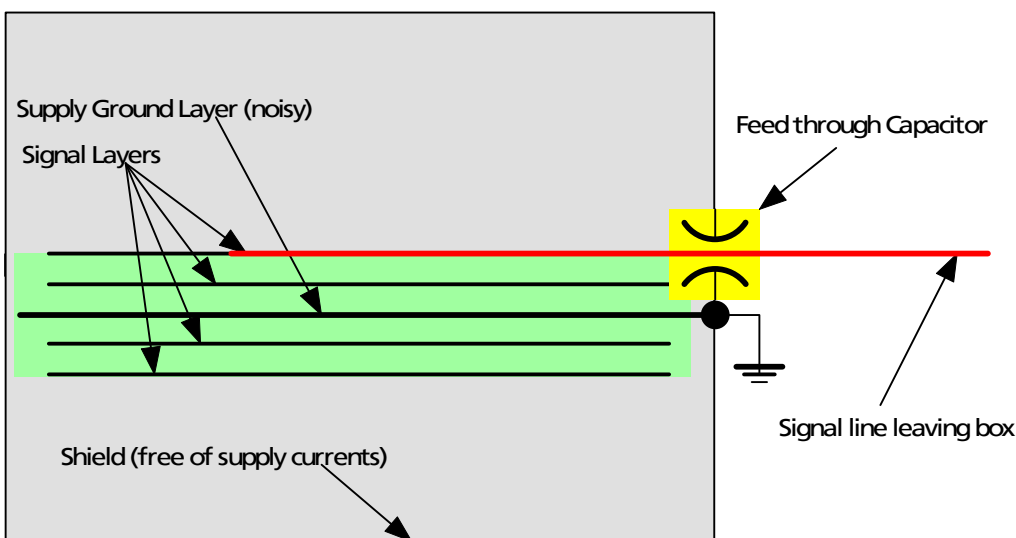

**Figure 19: Ideal shielding**

The proposed setup for such a system is shown in Figure 19. A feed through capacitor removes all high frequency content from the outgoing signal line. It's important to note that any conductor projecting through the shielding box is subject to picking up noise inside and re-radiating it outside, regardless of the actual signal it is intended to carry. Therefore, also DC lines (e.g. the power supply) should be filtered with feed through capacitors. When selecting feed through capacitors, it's important to choose components with appropriate frequency behavior. As with the ordinary capacitors, small value types will show better attenuation at high frequencies (see Figure 20). For the GPS frequency band the 470pF capacitor is the optimum choice of the Murata NFM21C series.

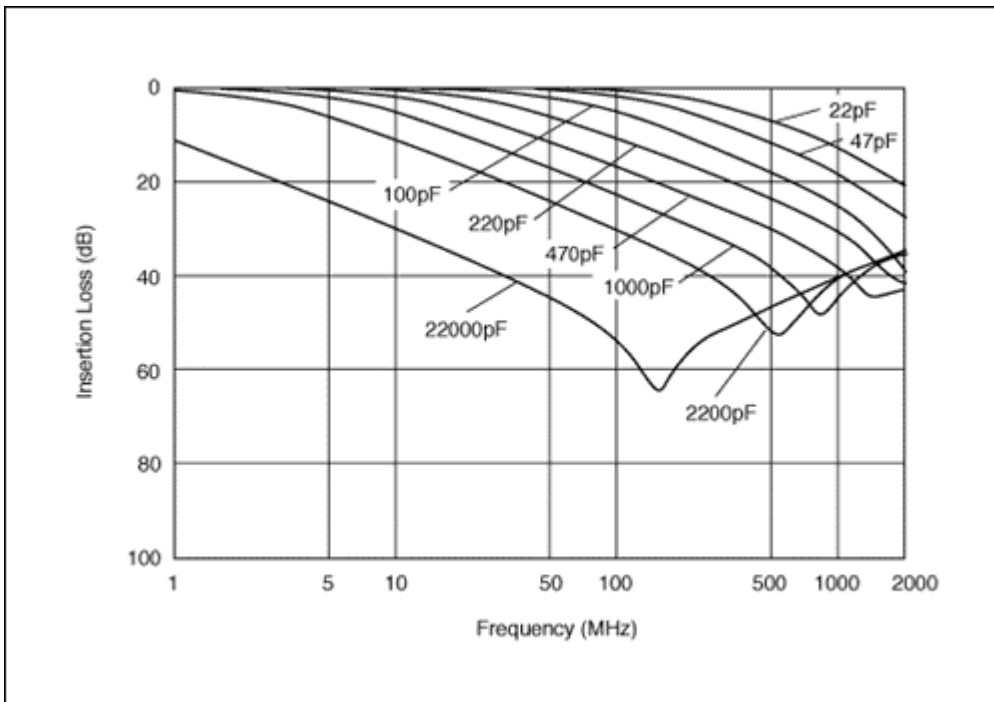

**Figure 20: MuRata's NFM21C Feed Through Capacitors**

Any feed through capacitor will only achieve its specified performance if it has a proper ground connection.

If the use of a special feed through capacitor is not feasible for a particular design, a simple capacitor between the signal line and shielding ground placed very close to the feed through of the signal line will also help. It has been found that a 12 pF SMD capacitor works quite well at the GPS frequency range. Larger capacitance values will be less efficient.

One should keep in mind that a feed through capacitor is basically a high frequency "short" between the signal line and ground. If the ground point that the capacitor is connected to is not ideal, meaning the ground connection or plane has a finite resistance, noise will be injected into the ground net. Therefore, one should try to place any feed through capacitor far away from the most noise sensitive parts of the circuit. To emphasize this once again, one should ensure a very good ground connection for the feed through capacitor.

If there is no good ground connection available at the point of the feed through, or injection of noise into the non-ideal ground net must be avoided totally, inserting a component with a high resistance at high frequencies might be a good alternative. Ferrite beads are the components of choice if a high DC resistance cannot be accepted. Otherwise, for ordinary signal lines one could insert a 1 K series resistor, which would then form a low-pass filter together with the parasitic capacitance of the conductor trace.

See also MuRata web page for extensive discussion on EMC countermeasures.

### 1.6.3.2 Shielding Sets of Sub-System Assembly

Yet another problem arises if multiple building blocks are combined in a single system. *Figure 21* shows a possible scenario. In this case, the supply current traveling through the inductive ground connection between the two sub-systems will cause a voltage difference between the two shields of the sub-system. The shield of the other system will then act as a transmitting antenna, radiating with respect to the ground and shield of the GPS receiver and the attached antenna.

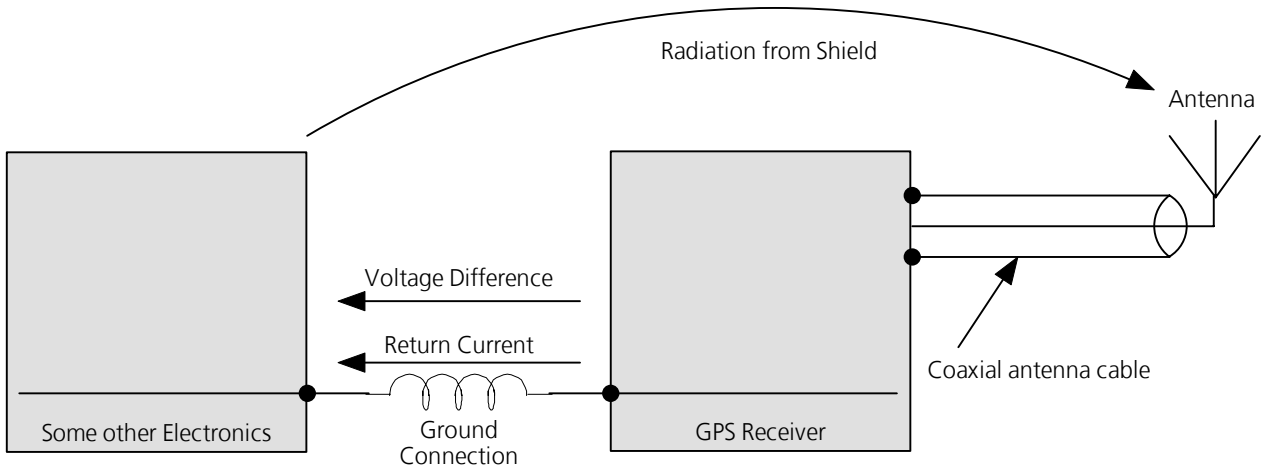

**Figure 21: Two shielded sub-systems, connected by a “poor” ground**

This situation can be avoided by ensuring a low inductivity ground connection between the two shields. But now, it might be difficult to control the path of the ground return currents to the power supply since the shield is probably connected to the supply ground at more than one location. The preferred solution is shown in *Figure 22*. Again, it is important to have a good (i.e. low inductance) interconnection between the outer shield and the shielding ground of the GPS receiver.

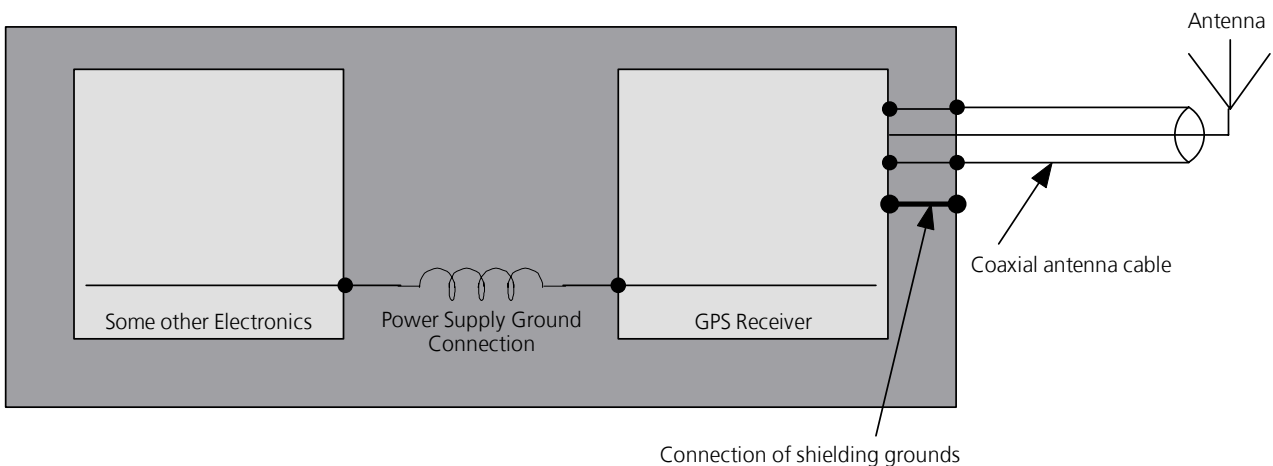

**Figure 22: Proper shielding of a sub-system assembly**

It is clear that the situation illustrated in *Figure 22* can become complex if the component “Some other electronics” contains another wireless transmitter system with a second antenna, which is referenced to the systems shielding ground. As already pointed out, in a setup like this it is important to keep the shield free from supply currents with high frequency spectral content. If there are to be additional connections to the shielding ground, these should be of a highly inductive nature.

## 1.7 High Sensitivity GPS (SuperSense® GPS)

GPS signals are already very weak when they arrive at the Earth's surface. By the time the GPS signals arrive at the receiver they are typically as weak as  $-130\text{dBm}$  ( $-160\text{dBW}$ ). This is well below the thermal noise level. Standard GPS receivers (e.g. TIM-4A) integrate the received GPS signals for up to 20ms. This results in the ability to track signals down to about  $-150\text{dBm}$  ( $-180\text{dBW}$ ). High Sensitivity GPS receivers are able to integrate the incoming signals much longer than this and can therefore track down to levels approaching  $-160\text{dBm}$ . High Sensitivity GPS can provide positioning in many but not all indoor locations. Signals are either heavily attenuated by the building materials or reflected in as multipath. High Sensitivity GPS Receivers can also compensate the performance deficits of smaller antennas.

For Standard GPS Receivers, signal reflections and multipath effects are undesirable phenomena. Indoor GPS reception, however, must - besides the direct line-of-sight signal - rely on reflected GPS signals in order to receive a sufficient number of satellites to calculate positions. Since reflections increase the propagation delays, the positioning accuracy will obviously decrease. Good High Sensitivity GPS Receivers like SuperSense® will tune their multipath suppression in such a way that multipath is suppressed on channels with strong signals in order to achieve an excellent accuracy whereas it accepts all signals in case of poor reception in order to provide an optimal GPS coverage.

The benefits of weak signal tracking come at a price. Customers must accept some tradeoffs while the signal level is low: Reduced acquisition performance (acquisition sensitivity, increased acquisition times), positioning accuracy and dynamic responsiveness.

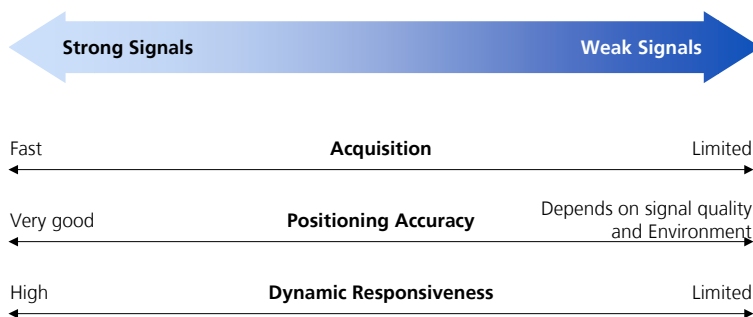

Figure 23: Trade-off in Weak Signal GPS

High Sensitivity GPS Receivers open new applications and market opportunities such as navigation in building interiors or the covert use of GPS receivers in vehicles and they help to drive down the costs by allowing the use of smaller GPS antennas.

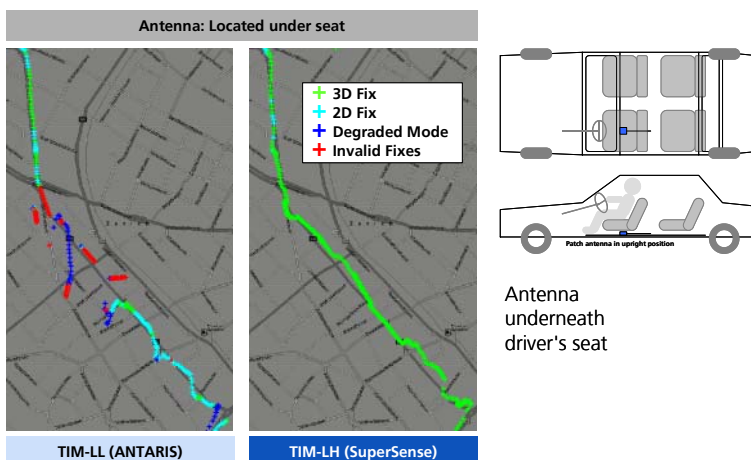

Figure 24: Improved GPS Coverage with High Sensitivity GPS Receivers

## 1.8 Assisted GPS / A-GPS

Assisted GPS, or A-GPS, is a technology that uses an assistance server to cut down the time needed to determine a location using GPS. It is useful in urban areas, when the user is located in "urban canyons", under heavy tree cover, or even indoors. It is becoming more common and it's commonly associated with Location Based Services (LBS) over cellular networks. Figure 25 depicts a typical A-GPS system.

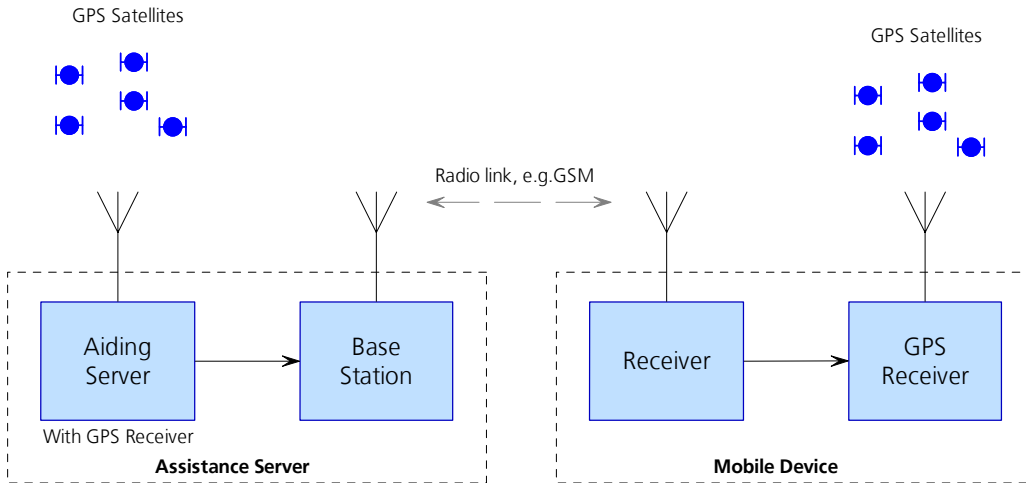

Figure 25: Aiding Topology

## 1.9 DGPS (Differential GPS)

Differential GPS (DGPS) provides slightly better accuracy than a stand-alone GPS receiver. The correction data from a reference station is transmitted to the GPS receiver in order to eliminate Pseudorange errors. Additional hardware is required to receive these data.

DGPS lost significance when the Selective Availability (SA) was discontinued in May 2000. These days, the applications of DGPS are typically limited to surveying

## 1.10 SBAS (Satellite Based Augmentation Systems)

SBAS (Satellite Based Augmentation System) is an augmentation technology for GPS, which calculates GPS integrity and correction data with RIMS (Ranging and Integrity Monitoring Stations) on the ground and uses geostationary satellites (GEOs) to broadcast GPS integrity and correction data to GPS users. The correction data is transmitted on the GPS L1 frequency (1575.42 MHz), and therefore there is no additional receiver required to make use of the correction- and integrity data.

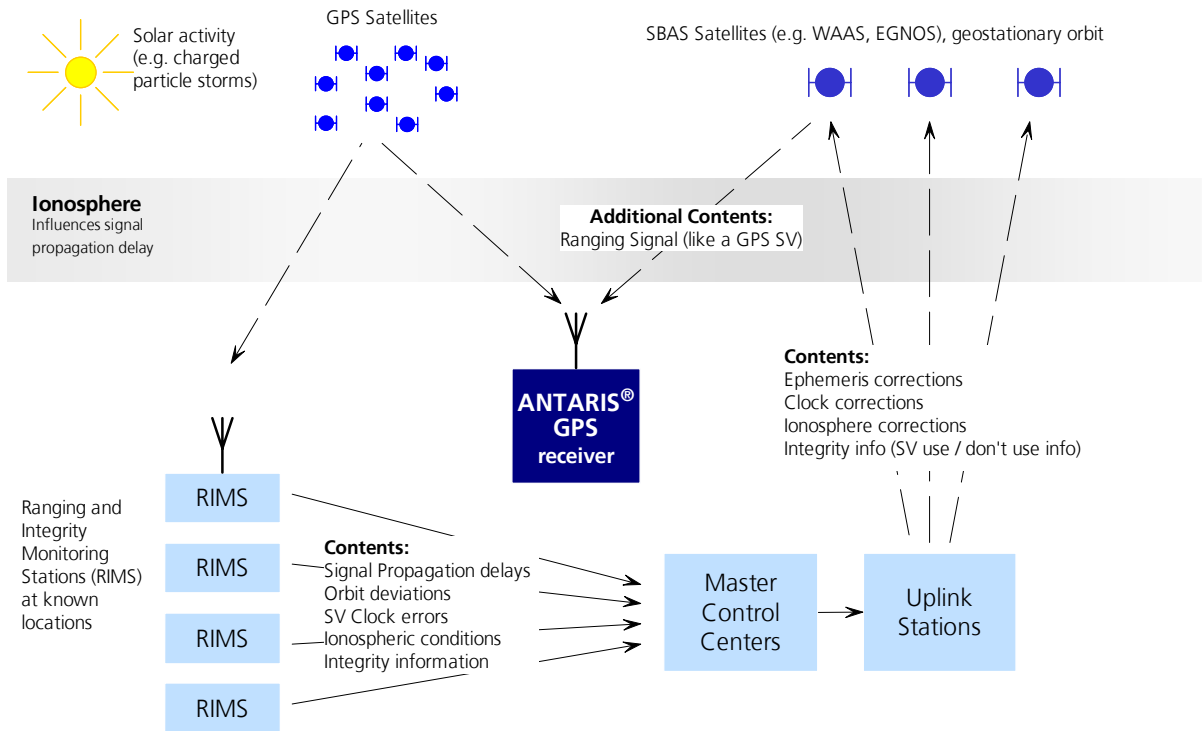

**Figure 26: SBAS-Principle**

There are several compatible SBAS systems available or in development all around the world:

- WAAS (Wide Area Augmentation System) for Northern America is in operation since 2003.
- EGNOS (European Geostationary Navigation Overlay Service) is in test mode ESTB (EGNOS satellite test bed). EGNOS has passed the ORR (Operational Readiness Review) in Q2/2005. Full operation of EGNOS is planned for 2007.
- MSAS (Multi-Functional Satellite Augmentation System) for Asia is in development stage and is sending test data. MSAS initial Operating Capability (IOC) is expected early 2007.

Other systems are planned for Canada (CSAS), India (GAGAN), Africa (EGNOS) and South America.

SBAS support allows the ANTARIS<sup>®</sup>4 Technology to take full benefit of the augmentation systems that are available (WAAS, EGNOS), the test beds (NSTB, ESTB) and future systems that are planned (such as MSAS) for non-avionics applications.

With SBAS enabled the user benefits of additional satellites for ranging (navigation). The ANTARIS<sup>®</sup>4 Technology uses the available SBAS Satellites for navigation just like GPS satellites, if the SBAS satellites offer this service.

To improve position accuracy SBAS uses different types of correction data:

- **Fast Corrections** account for short-term disturbances in GPS signals (due to clock problems, etc).
- **Long-term corrections** cancel effects due to slow GPS clock problems, broadcast orbit errors etc.
- **Ionosphere corrections** cancel effects due to Ionosphere activity

Another benefit is the use of GPS integrity information. In that way SBAS Control stations can 'disable' usage of GPS satellites in case of major GPS satellite problems within 6 seconds time to alarm. The ANTARIS®4 GPS Technology will only use satellites, for which integrity information is available, if integrity monitoring is enabled.

For more information on SBAS and associated services please refer to

- RTCA/DO-229C (MOPS). Available from [www.rtca.org](http://www.rtca.org)
- [gps.faa.gov](http://gps.faa.gov) for information on WAAS and the NSTB
- [www.esa.int](http://www.esa.int) for information on EGNOS and the ESTB
- [www.essp.be](http://www.essp.be) for information about European Satellite Services Provider EEIG is the EGNOS operations manager.

### SBAS GEO PRN Numbers

The PRN of the GEO's used for SBAS are in a range from 120 to 150. shows the SBAS GEO's in operation.

GEO identification	Stationed over	GPS PRN	SBAS Provider
INMARSAT AOR-E (Atlantic Ocean Region East)	Eastern Africa	120	EGNOS
INMARSAT AOR-W (Atlantic Ocean Region West)	Western Africa	122	WAAS
Artemis	Africa (Congo)	124	EGNOS
INMARSAT IOR-W (III-F5) (Indian Ocean Region West)	Africa (Congo)	126	EGNOS
MTSAT-1R	Pacific	129	MSAS
INMARSAT IOR (Indian Ocean Region)	Indian Ocean	131	EGNOS
INMARSAT POR (Pacific Ocean Region)	Pacific	134	WAAS
PanAmSat Galaxy 15	133 degrees west	135	WAAS
MTSAT-2	Pacific (not launched yet)	137	MSAS
Telesat Anik / F1R	107 degree west	138	WAAS

Table 2: PRN of GEO's used for SBAS

## 1.11 Dead Reckoning enabled GPS (DR)

Dead reckoning is a feature to make GPS more accurate and reliable in urban canyon environments and during periods of GPS outage. It uses extra sensors (in addition to GPS) installed in the vehicle to measure its speed, heading and direction (forward, backward). Therefore a DR enabled Receiver consists of a GPS receiver, a turn rate sensor (gyroscope) and a speed indicator (odometer). By combining the information of all sensors a position can be determined even if GPS positioning is degraded or impossible due to restricted sky view. This means that a DR enabled receiver continues to report positions, when GPS signals are blocked, such as in tunnels or in heavy urban canyon environments.

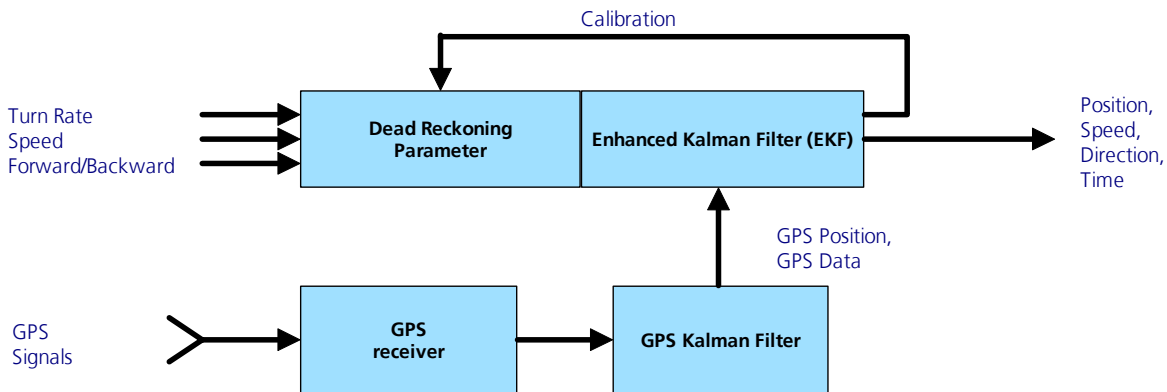

Figure 27: Dead Reckoning Block diagram



### 1.11.1 Dead Reckoning Principal

In contrast to GPS, which delivers absolute positions, Dead Reckoning is a relative method. The sensors give information for a defined measurement period, and the location is calculated relative to the previously known position. Therefore an absolute GPS position is required as a starting point, which is the last known GPS position.

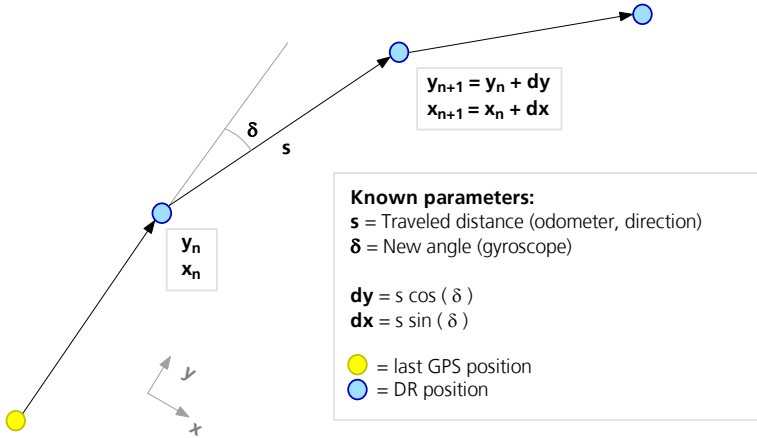

Figure 28: Dead Reckoning Principle

Parameters used for the relative position calculation are:

- **Distance traveled:** Odometer pulses
- **Direction:** Forward / backward indicator
- **Angular turn rate:** Gyroscope

### 1.11.2 Dead Reckoning Performance

As DR is an incremental algorithm, the quality of the DR position depends very much on the quality and stability of the sensors used. An accurate model, low tolerances and low thermal drifts are fundamental for reliable position output.

The performance figures of a DR system are always relative to traveled distance or time.

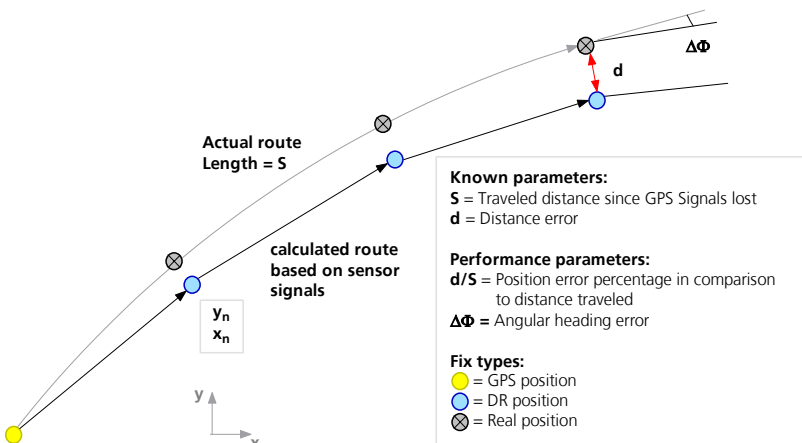
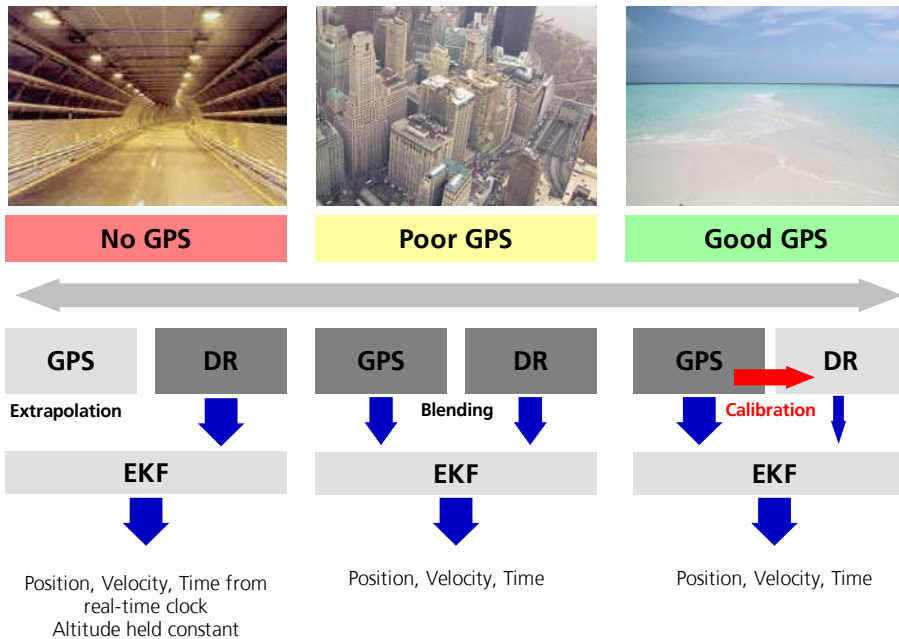

Figure 29: Dead Reckoning Performance Parameters

The seamless transition between absolute GPS positions and relative DR positions is advantageous in getting optimal performance from a DR enabled GPS receiver. ANTARIS<sup>®</sup>4 GPS Technology employs blended algorithms to obtain the optimum from both systems.

GPS Positioning is weighted more heavily as long as the GPS parameter (e.g. DOP, number of satellites, signal quality) indicates good and reliable performance. In situations, where the GPS signals are poor, reflected from buildings (multipath) or jammed, the DR solution is used with a higher weighting.



**Figure 30: Dead Reckoning Blending**

- **No GPS:** During GPS loss, only DR- (sensor based) positions are reported. The position is calculated based on the signals of the turn rate sensor and speed sensor, with reference to the last known GPS solution.
- **Poor GPS:** In urban canyons with fast changing sky visibility or during degraded GPS reception, the ANTARIS®4 DR Technology performs a calculation by blending the GPS and sensor based positioning.
- **Good GPS:** With good GPS performance and optimal sky view, the GPS position has a higher weight than the DR/sensor based position on the overall navigation solution. In this situation, the GPS position values are used to calibrate the DR sensors or to perform sensor integrity checks (to establish if the sensors are well calibrated).

## 2 System Consideration

### 2.1 Introduction

All ANTARIS<sup>®</sup>4 products run on the same GPS engine. The different types of receivers differ mainly in flexibility and user specific features.

#### Power consumption

- ANTARIS<sup>®</sup>4 runs on an optimized Continuous Power Mode.
- For applications with defined off times and for very low power consumption applications, FixNOW<sup>™</sup> can be enabled (for details refer to *Section 4.2.7*).

#### Antenna

- ANTARIS<sup>®</sup>4 receivers support active and passive antennas of different technologies and shapes.
- The antenna short circuit detection is a standard feature of ANTARIS<sup>®</sup>4. Antenna open circuit detection is optional.

#### Acquisition

- Whenever Hot- or Warmstart functions are needed, a backup battery is required.
- Different sensitivity settings allow an acquisition performance optimized to user requirements.
- For very fast start-up utilise the aiding function.

#### Navigation Performance/ GPS Technology

- Standard GPS receivers offer highest reliability.
- SuperSense<sup>®</sup> GPS receivers are aimed at applications with maximum coverage requirements.
- Timing receivers allow very accurate timing output even if only one satellite is available.
- Dead reckoning receivers target automotive applications, which require 100% coverage combined with high accuracy. The EKF (Enhanced Kalman Filter) technology is the best way to combine GPS positioning with GYRO and speed information to get reliable positioning even in obstructed areas and tunnels.

#### Configuration

- ANTARIS<sup>®</sup>4 receivers are highly configurable (e.g. Navigation Settings, SBAS support, Antenna Supervision, NMEA protocol, Baudrate etc.).
- Programmable receivers allow firmware upgrade and storage of customer configuration to non-volatile memory (FLASH).
- Low cost receivers have only a selected number of start-up configurations. More configurations can be made through the serial port and stored into Battery Backup RAM.
- ANTARIS<sup>®</sup>4 supports standard serial communication based on UART technology. LEA and NEO modules also offer an integrated USB port.

## 2.2 Technology

### 2.2.1 Standard GPS Receivers

Standard GPS receivers are based on u-blox's high performance 16-channel ANTARIS®4 technology. They represent an excellent compromise between low cost and high performance, which makes them the ideal choice for most applications.

### 2.2.2 SuperSense® GPS Receiver

SuperSense® GPS receivers are also based on u-blox's high performance ANTARIS®4 technology. They include a more accurate time base (TCXO) and additional software, providing up to 10dB additional sensitivity, which allows these receivers to be used in challenging environments.

### 2.2.3 Precision Timing GPS Receivers

Precision Timing GPS Receivers are designed to output highly accurate time signals. For this purpose they come with a TCXO crystal and a special firmware, which is capable of providing accurate time information (Timemark or stop watch function) even if only a single satellite signal is available. Additionally, timing receivers can be used for post processing purposes.

### 2.2.4 DR enabled Receivers

DR enabled receivers support additional interfaces for gyro, odometer, direction and temperature sensor signals. This allows providing positions in areas with obstructed sky view (e.g. tunnels) where GPS-only receivers are unable to function.

## 2.3 Product Categories

### 2.3.1 Low Cost Receivers (ROM only)

Low Cost Receivers provide an optimal GPS performance at low price. These modules execute the firmware directly from internal ROM and have only a limited configuration set.

### 2.3.2 Programmable Receivers (Receivers with integrated FLASH memory)

Programmable receivers contain flash memory to support firmware upgrades and the permanent storage of configuration settings.

## 2.4 Form Factors

All module form factors are based on the same GPS engine. The main difference between the form factors (apart from size) lies in the number of pins available for communication and configuration.

### 2.4.1 NEO Modules



Figure 31: NEO form factor

The NEO form factor is 16.0 x 12.2 x 2.8 mm and has 24 pins. It supports one USART and one USB communication interface and is optimized for minimal floor space compared to the TIM and LEA form factors. NEO modules allow fully automatic assembly and soldering.

### 2.4.2 LEA Modules

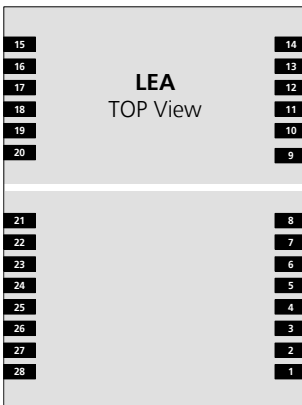
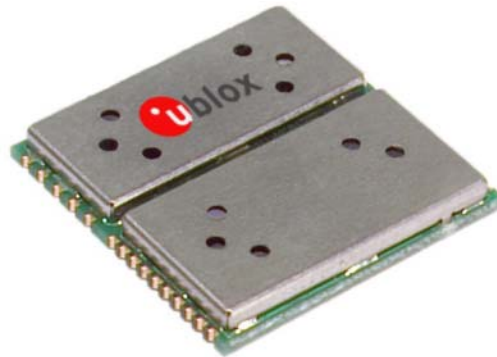
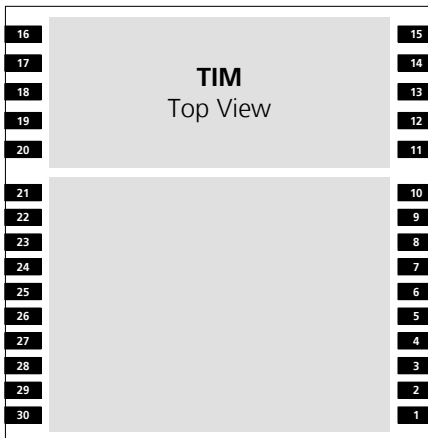

Figure 32: LEA form factor

The LEA form factor is 17.0 x 22.4 x 3 mm and has 28 pins. It supports one USART and one USB communication interface and is optimized for minimal floor space compared to the TIM form factor. The LEA form factor is now available in its 2<sup>nd</sup> generation (LEA-LA, LEA-4x) allowing u-blox customers to profit from technological advances without having to redesign their applications. LEA modules allow fully automatic assembly and soldering.

### 2.4.3 TIM Modules



**Figure 33: TIM form factor**

The TIM form factor is 25.4 x 25.4 x 3 mm and has 30 pins. u-blox introduced this form factor to the market in 2004 and it is now available in the 3<sup>rd</sup> generation (TIM-ST, TIM-Lx, TIM-4x) allowing u-blox customers to profit from technological advances without having to redesign their applications. TIM modules allow fully automatic assembly and soldering.

## 2.5 Choosing the optimal module

The family of ANTARIS<sup>®</sup>4 GPS receiver modules is shown in Figure 34. The optimal choice depends on the specific application requirements.

- For Timing Applications choose LEA-4T
- For DR Applications choose LEA-4R or TIM-4R.
- If USB is required or generally for new developments, use the LEA or NEO from factor
- If the module replaces an existing ANTARIS<sup>®</sup> receiver based on the TIM form factor or if two serial ports are required, the TIM form factor is recommended.
- If minimal board space is important, decide for the NEO form factor.
- If a temperature range of  $-30^{\circ}\text{C}$  to  $+70^{\circ}\text{C}$  is sufficient, consider using LEA-4M.

For all form factors, there are Low Cost and Programmable Receivers available:

- Choose Programmable receivers if the possibility of firmware upgrades is desired or if the permanent storage of special configuration settings is required.
- Choose ROM based receivers for cost-sensitive PVT applications.



	Standard GPS		SuperSense <sup>®</sup> Indoor		Precision Timing GPS	Dead Reckoning GPS
	ROM Based	Programmable	ROM Based	Programmable	Programmable	Programmable
<b>NEO</b> 1 Serial Ports 1 USB Interface  12.2 x 16 mm	N/A	N/A	<b>NEO-4S</b>	N/A	N/A	N/A
<b>LEA</b> 1 (2) Serial Ports 1 USB Interface  17 x 22 mm	<b>LEA-4A</b> <b>LEA-4M</b>	<b>LEA-4P</b>	<b>LEA-4S</b>	<b>LEA-4H</b>	<b>LEA-4T</b>	<b>LEA-4R</b>
<b>TIM</b> 2 Serial Ports  25 x 25 mm	<b>TIM-4A</b>	<b>TIM-4P</b>	<b>TIM-4S</b>	<b>TIM-4H</b>	N/A	<b>TIM-4R</b>

Figure 34: ANTARIS<sup>®</sup>4 GPS module family

### 2.5.1 ANTARIS® 4 Feature Matrix

Module Type	ANTARIS® <sup>2</sup>						ANTARIS® 4													
	Low Cost		Programmable				Low Cost			Pro-grammable		Low Cost			Pro-grammable		Time	DR		
	TIM-LA TIM-LC		TIM-LL TIM-LF TIM-LP	TIM-LH	TIM-LR	LEA-4M	LEA-4A	TIM-4A	LEA-4P	TIM-4P	LEA-4S	NEO-4S	TIM-4S	LEA-4H	TIM-4H	LEA-4T	TIM-4R	LEA-4R		
Passive Antenna	only LA		only LL/LP	●	●	●	●	●	●	●	●	●	●	●	●	●	●	●		
Active Antenna	●		●	●	●	●	●	●	●	●	●	●	●	●	●	●	●	●		
Flash memory			●	●	●			●	●				●	●	●	●	●	●		
Serial Interfaces	2		2	2	2	2	2	2	1	2	2	1	2	1	2	1	2	1		
USB port						1	1		1		1	1		1		1		1		
Boot-Time Configuration Pins	●					●	●	●			●		●							
TIMEPULSE	●		●	●	●	●	●	●	●	●	●		●	●	●	●	●	●		
SuperSense®				●							●	●	●	●	●					
Dead Reckoning					●												●	●		
RAW Data Output	●		●	●												●				
Time Mode Timer/ Counter																●				
Supply voltage	2.7 –3.3 V					2.7 –3.3 V														
Power consumption	■ ■ ■ ■	■ ■ ■ ■	■ ■ ■ ■	■ ■ ■ ■		■	■	■	■ ■ ■ ■	■ ■ ■ ■	■	■	■	■ ■ ■ ■	■ ■ ■ ■	■ ■ ■ ■	■ ■ ■ ■	■ ■ ■ ■		
Temperature range	-40 +85°C					-30 .. +70°C			-40 +85°C											

●: Supported      ■: Qualitative indications, for detailed figures refer to the datasheet of the individual receiver

**Table 3: Choosing the optimal ANTARIS® GPS module**

<sup>2</sup> ANTARIS® receivers are in the end-of-life process. Migrate all ANTARIS® receivers to ANTARIS®4 (see appendix D).



## 2.6 Compatibility of ANTARIS® GPS receivers

The ANTARIS®4 GPS modules are designed for a high level of compatibility, even over product generations. Depending on customer requirements a design may start with a low cost receiver and can be changed to a SuperSense® GPS receiver in the final design.

		Standard GPS		SuperSense® Indoor GPS		Dead Reckoning
		Low Cost	Programmable	Low Cost	Programmable	Programmable
Migration Path	ANTARIS	TIM-LA TIM-LC <sup>*)</sup>	TIM-LL TIM-LP TIM-LF <sup>*)</sup>	N/A	TIM-LH	TIM-LR
	ANTARIS 4	TIM-4A	TIM-4P	TIM-4S	TIM-4H	TIM-4R

<sup>\*)</sup> No LNA inside

Figure 35: Compatibility of ANTARIS® TIM receivers

		Standard GPS		SuperSense® Indoor GPS		Precision Timing GPS
		Low Cost	Programmable	Low Cost	Programmable	Programmable
Migration Path	ANTARIS	LEA-LA	N/A	N/A	N/A	N/A
	ANTARIS 4	LEA-4A	LEA-4P	LEA-4S	LEA-4H	LEA-4T

Figure 36: Compatibility of ANTARIS® LEA receivers

## 2.7 Active vs. Passive Antenna

First some general issues:

- A GPS receiver needs to receive signals from as many satellites as possible. A GPS receiver cannot provide optimal performance in narrow streets between high buildings (i.e. in urban canyons), in underground parking lots or if objects cover the antenna. Poor sky visibility may result in position drift or a prolonged Time-To-First-Fix (TTFF). **Therefore, good sky visibility is very important.**
- A GPS receiver will only achieve the specified performance if the average Carrier-To-Noise-Ratio (C/No) of the strongest satellites reaches at least 44 dBHz. In a well-designed system, the average of the C/No ratio of high elevation satellites should be in the range between 44 dBHz and about 50 dBHz. With a standard off-the-shelf active antenna, 47 dBHz should easily be achieved. **Even the best receiver can't make up for signal loss due to a poor antenna, in-band jamming or a bad RF-board design.**

Table 4 looks at some of the issues to consider when selecting active or passive antennas.

Active Antenna	Passive Antenna
Active antenna connected to the GPS module.	Passive patch antennas, chip antennas or helical antennas connected with a micro strip or strip line to the GPS module.
<p>A wide range of active patch or helical antennas are available on the market. They differ in size, sensitivity and power consumption</p> <ul style="list-style-type: none"> <li>• Needs more power than a passive antenna</li> </ul>	<ul style="list-style-type: none"> <li>• Passive patch antennas or helical antennas are available in different form factors and sensitivities</li> <li>• Antenna must be connected with a carefully designed micro strip or strip line to the GPS module to ensure a good GPS performance.</li> <li>• The PCB design with a passive antenna must consider the sensitivity of the GPS antenna to other radiating circuits or general signal jamming.</li> <li>• Due to the proximity of antenna, GPS and other electronic circuits, in-band jamming may become a critical issue.</li> </ul>

**Table 4: Active vs. Passive Antenna**

 **Note** Take an active antenna, if you are not an expert in RF designs and place the antenna away from noise emitting circuits.

## 3 Design-In

This section provides a Design-In Checklist as well as Reference Schematics for new designs with ANTARIS®4. For migration of existing ANTARIS® product designs to ANTARIS®4 please refer to *Appendix D*.

For a Design-In for the LEA-4R/TIM-4R Dead Reckoning GPS Modules refer to the *LEA-4R/TIM-4R System Integration Manual* [7].

### 3.1 Schematic Design-In Checklist for ANTARIS®4

**A4**

Designing-in a TIM-4x, LEA-4x or NEO-4x GPS receiver is easy especially when a design is based on the reference design in *Appendix C*. Nonetheless, it pays-off to do a quick sanity check of the design. This section lists the most important items for a simple design check. The Layout Checklist in *Section 3.4* also helps to avoid an unnecessary respin of the PCB and helps to achieve the best possible performance.

- Note** It's highly recommended to follow the Design-In Checklist when developing any ANTARIS®4 GPS applications. This may shorten the time to market and the development cost significantly.

#### Have you chosen the optimal module?

The ANTARIS®4 receiver family has been intentionally designed to allow GPS receivers to be optimally tailored to specific applications (see also *Section 2.3*). Changing between the different variants is easy (see *Section 3.2*)

- Do you need SuperSense (see *Section 1.7 and 4.5.5*)? – Then choose an xxx-x**H** or xxx-x**S** class receiver.
- If you want to be able to upgrade the firmware or to permanently save configuration settings, you will have to use Programmable receiver module? – Then choose an xxx-x**H** or xxx-x**P** class receiver.

#### Check Power Supply Requirements and Schematic (*Section 4.2.1*):

- Is the power supply within the specified range?
- Are the voltages **VDDIO** and **VDDUSB** within the specified range?
- Place any LDO as near as possible to the **VCC** pin of the module; if this is not possible design a wide power track or even a power plane to avoid resistance between the LDO/ power source and the GPS Module.
- The ripple on **VCC** has to be below 50mVpp?

#### Backup Battery (see *Section 4.2.2*)

- For achieving a minimal TTF after a power down, make sure to connect a backup battery to **V\_BAT**.
- When you connect the backup battery for the first time, make sure **VCC** is on or – if not possible – power up the module for a short time (e.g. 1s) ASAP in order to avoid excessive battery drain (see *Section 4.2.2*).
- While power off, make sure there are no pull-up or down resistors connected to the RxD1, RxD2, EXTINT0 and EXTINT1 as this could cause significant backup or sleep current (>25µA or more instead of 5µA). Check if you followed the recommendations in *Section 4.2.3*.

#### Antenna (see *Section 4.3*)

- The total noise figure should be well below 3dB.
- If a patch antenna is the preferred antenna, choose a patch of at least 18x18mm. 25x25mm is even better.
- Make sure the antenna is not placed close to noisy parts of the circuitry. (e.g. micro-controller, display, etc.)
- For active antennas add a 10R resistor (see *Section 4.3.3.2*) in front of **V\_ANT** input for short circuit protection or use the antenna supervisor circuitry (see *Section 4.3.3.2*).
- Use an inductor to provide the antenna supply voltage for LEA-4M and NEO-4S (sections *4.3.3.1* and *3.6.6*).
- For migration of ANTARIS® Supervisor circuitry to ANTARIS®4, reduce R5 to 33k (Vant = 2.6 ...6.0V)

- ❑ When migrating from an ANTARIS GPS receiver (TIM-Lx or LEA-LA), reduce R5 of the Antenna Short and Open Supervisor circuit to 33k (see *Section 4.3.3.2*).

### Serial Communication (see *Section 4.3*)

- ❑ Choose UBX for an efficient (binary) data handling (see *Section 4.4.3*) or if more data is required than supported by NMEA (see *Section 4.4.4*)
- ❑ When using UBX protocol, check if the UBX quality flags (see *Section 4.6.9.2*) are used properly.
- ❑ Choose NMEA for compatibility to other GPS services, e.g. TIM-ST (see *Section 4.4.4*)
- ❑ Customize the NMEA output if required (e.g. NMEA version 2.3 or 2.1, number of digits, output filters etc.)

### Schematic

- ❑ If required, does your schematic allow using different TIM-4x or LEA-4x variants? For TIM-4x modules see *Table 82* for a comparison, for LEA-4x refer to *Table 83*.
- ❑ Leave the **RESET\_N** pin open if not used. Don't drive it high (see *Section 4.9.2*)!
- ❑ Leave **BOOT\_INT** pin open if not used for firmware update.
- ❑ Check the **GPSMODE** pins connection for start-up configuration of Low Cost Receivers (see *4.8.2*).
- ❑ Plan use of 2<sup>nd</sup> interface (USB or serial port) for firmware updates or as a service connector.

## 3.2 LEA-4x Design

**A4**

For a minimal Design with LEA-4x the following function and pins have to be considered:

- Connect the Power supply to VCC when the device is self-powered. In case of bus-powered devices, connect the USB power supply to a LDO before feeding it to Vcc and VDDUSB.
- Assure a optimal ground connection to all ground pins of the LEA module
- Connect the antenna to RF\_IN over a matching 50 Ohm micro strip and define the antenna supply (V\_ant) for active antennas (internal or external power supply)
- If an active antenna shall be connected to LEA-4M, make sure add an inductor for the antenna bias voltage as shown in section *4.3.3.1* and follow the layout recommendations in section *3.6.6*.
- Choose the required serial communication interface (USART or USB) and connect the appropriate pins to your application
- If you need Hot- or Warmstart in your application, connect a Backup Battery to V\_BAT
- Decide whether TIMEPULSE, RESET or BOOTMODE option are required in your application and connect the appropriate pins on your module
- Have you chosen the module with the correct temperature range?

This is a minimal setup for a PVT GPS receiver with LEA-4x modules. Now check about special functions and design requirements in *Table 5*.

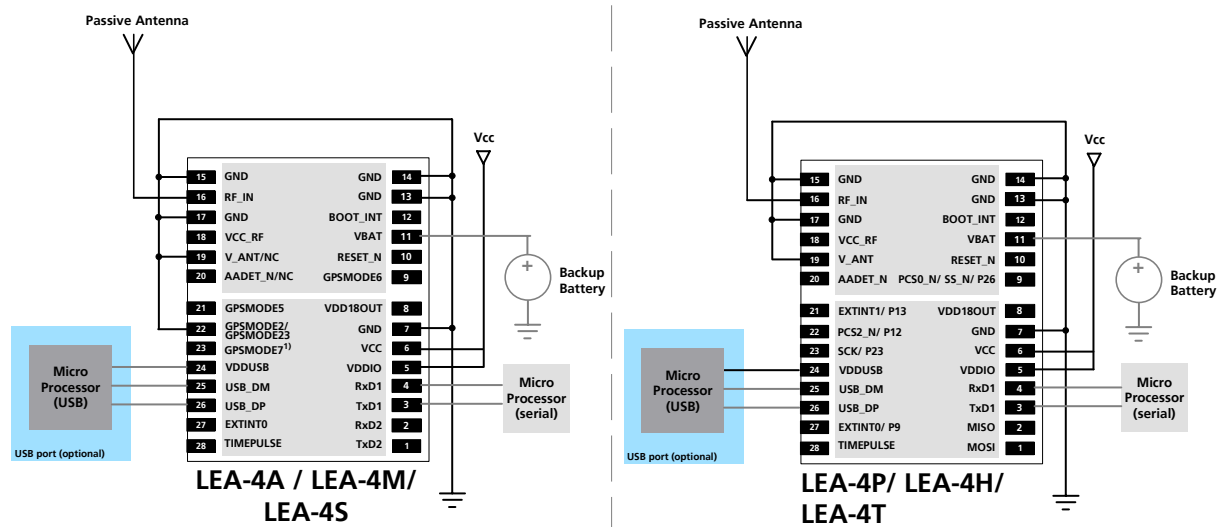

1) USB selfpowered setting

Figure 37: Passive Antenna Design for LEA-4x Receivers

Function	PIN (LEA)	I/O	Description	Remarks
<b>Power</b>				
VDDIO	5	I	Supply voltage for digital I/O pins	Power Supply for the digital I/O pins (e.g. serial ports, <b>TIMEPULSE</b> ). Must be connected to <b>VDD18OUT</b> , <b>VCC</b> or other voltage source meeting datasheet specification. <b>Never leave open!</b>
VCC	6	I	Supply Voltage	Max allowed ripple on <b>VCC</b> =50mVpp
GND	7, 13-15, 17	I	Ground	Assure a good <b>GND</b> connection to all <b>GND</b> pins of the module, preferably with a large ground plane (for details refer to <i>Section 3.6.4</i> )
VDD18OUT	8	O	1.8V supply output	1.8V output voltage reference. Leave open if not used.
VBAT	11	I	Backup voltage supply	It's recommended to connect a backup battery to <b>V_BAT</b> in order to enable Warm and Hot Start features on the receivers. Otherwise connect to <b>GND</b> . See also <i>Section 4.2.2</i> .
VDD_USB	24	I	USB Power Supply	To use the USB interface connect this pin to 3.0 – 3.6V. See also <i>Section 4.4.2</i> If no USB serial port used connect to <b>GND</b> .
<b>Antenna</b>				
RF_IN	16	I	GPS signal input from antenna	The connection to the antenna has to be routed on the PCB. Use a controlled impedance of 50 Ohm to connect <b>RF_IN</b> to the antenna or the antenna connector (for details refer to <i>Section 3.6.5</i> ) Don't supply DC through this pin. Use <b>V_ANT</b> pin to supply power.
VCC_RF	18	O	Output Voltage RF section	Can be used to power an external active antenna ( <b>VCC_RF</b> connected to <b>V_ANT</b> ). The max power consumption of the Antenna must not exceed the datasheet specification of the module (see also 4.3.3). Leave open if not used.
V_ANT	19	I	Antenna Bias voltage	Connect to <b>GND</b> if Passive Antenna is used. If an active Antenna is used, add a 10R resistor (see 4.3.3.2) in front of <b>V_ANT</b> input to the Antenna Bias Voltage or <b>VCC_RF</b> for short circuit protection or use the antenna supervisor circuitry (see 4.3.3.2). This pin is not available on LEA-4M (see section 3.6.6 for more information).
AADET_N	20	I	Active Antenna Detect	Input pin for optional antenna supervisor circuitry (see 4.3.3.2). Leave open if not used. This pin is not available on LEA-4M (see section 3.6.6 for more information).

Function	PIN (LEA)	I/O	Description	Remarks
<b>Serial Port /USB</b>				The serial output voltage levels on Tx depend on the applied VDDIO voltage level.
<b>TxD1</b>	3	O	Serial Port 1	<b>VDDIO</b> serial port output. Leave open if not used.
<b>RxD1</b>	4	I	Serial Port 1	5V tolerant serial port input with internal pull-up resistor to <b>V_BAT</b> . Leave open if not used. <b>Note</b> Don't use an external pull up resistor.
<b>TxD2<sup>3</sup></b>	1	O	Serial Port 2	<b>LEA-4A / LEA-4S / LEA-4M</b> (only): <b>VDDIO</b> serial port output. Leave open if not used.
<b>RxD2</b>	2	I	Serial Port 2	<b>LEA-4A / LEA-4S / LEA-4M</b> (only): 5V tolerant serial port input with internal pull-up resistor to <b>V_BAT</b> . Leave open if not used. <b>Note</b> Don't use an external pull up resistor.
<b>USB_DM</b>	25	I/O	USB I/O line	USB1.1 bidirectional communication pin. To be fully compliant with USB standard follow the schematic recommendation in <i>Section 4.4.2</i> .
<b>USB_DP</b>	26			
<b>System</b>				
<b>BOOT_INT</b>	12	I	Boot mode	Do not connect on LEA-4A, <b>LEA-4M</b> and LEA-4S receivers.
<b>RESET_N</b>	10	I	Hardware Reset (Active Low)	Leave open if not used. Do not drive high. See also <i>Section 4.9.2</i> .
<b>TIMEPULSE</b>	28	O	Timepulse Signal	Configurable Timepulse signal (one pulse per second by default). Leave open if not used. See also <i>Section 4.7.1</i> .
<b>EXTINT0</b>	27		External Interrupt	External Interrupt Pin to wake up receiver in FixNOW™ sleep mode. See also <i>Section 4.2.7.1</i> and <i>4.9.4</i> for further information. Internal pull-up resistor to <b>V_BAT</b> . Leave open if not used.
<b>GPSMODE6/ PCSO_N/ SS_N/ P26</b>	9	I/O	GPIO/ GPSMODE Pin	<b>LEA-4A/ LEA-4S/ LEA-4M:</b> GPSMODE Pin; leave open if default configuration is used. Refer to <i>Section 4.8.2</i> for further information
<b>GPSMODE5/ EXTINT1/ P13</b>	21	I/O		<b>LEA-4P / LEA-4H/ LEA-4T:</b> GPIO Pin; leave open if not used
<b>GPSMODE23<sup>4</sup>/ GPSMODE2/ PCSO_N/P12</b>	22	I/O		The General Purpose I/O (GPIO) can only be programmed with the ANTARIS®4 Software Customization Kit, please refer to the <i>SCK Manual [8]</i> when intending to use of the GPIO's of the receiver.
<b>GPSMODE7/ SCK/ P23</b>	23	I/O	USB Boot time configuration pin	<b>LEA-4A/ LEA-4S / LEA-4M:</b> Defines the Power Supply mode of the GPS module. <b>GPSMODE7</b> =high (default) means that the module has it's own power supply. <b>GPSMODE7</b> =low means that the GPS module is powered by the USB bus. Connect to <b>GND</b> , when Bus Powered Mode is required. Otherwise leave open. For details about configuration settings refer to <i>Section 4.8.2</i> . <b>LEA-4P / LEA-4H/ LEA-4T:</b> GPIO Pin; leave open if not used The General Purpose I/O (GPIO) can only be programmed with the ANTARIS®4 Software Customization Kit, please refer to <i>the SCK Manual [8]</i> when intending to use of the GPIO's of the receiver.
<b>MOSI/ P24</b>	1	I/O	GPIO	<b>LEA-4H / TIM-4P</b> (only): GPIO Pin; leave open if not used
<b>MSIO/ P25</b>	2	I/O		<b>Note</b> Used as <b>RxD2/ TxD2</b> on LEA-4A / LEA-4S/ LEA-4M receivers.

Table 5: Pinnout LEA-4x

<sup>3</sup> Used as **MOSI /MISO/ GPIO** pins on LEA-4H, LEA-4P and LEA-4T receivers.

<sup>4</sup> Connecting the GPSMODE23 pin (LEA-4S) to GND increases the FixNOW sleep mode current by about 50µA. Connecting the GPSMODE2 pin (LEA-4A to GND does however not have an impact on the FixNOW sleep mode current.

### 3.3 TIM-4x Design

For a minimal Design with TIM-4x the following functions and pins have to be considered:

- Connect the Power supply to VCC.
- Assure a optimal ground connection to all ground pins
- Connect the antenna to RF\_IN over a matching 50 Ohm micro strip and define the antenna supply for active antennas (internal or external power supply)
- If you need Hot- or Warmstart in your application, connect a Backup Battery to V\_BAT
- Decide whether TIMEPULSE, RESET or BOOTMODE option are required in your application and connect the appropriate pins on your module

This is a minimal setup for a PVT GPS receiver with TIM-4x modules. Now check about special functions and design requirements in *Table 6*.

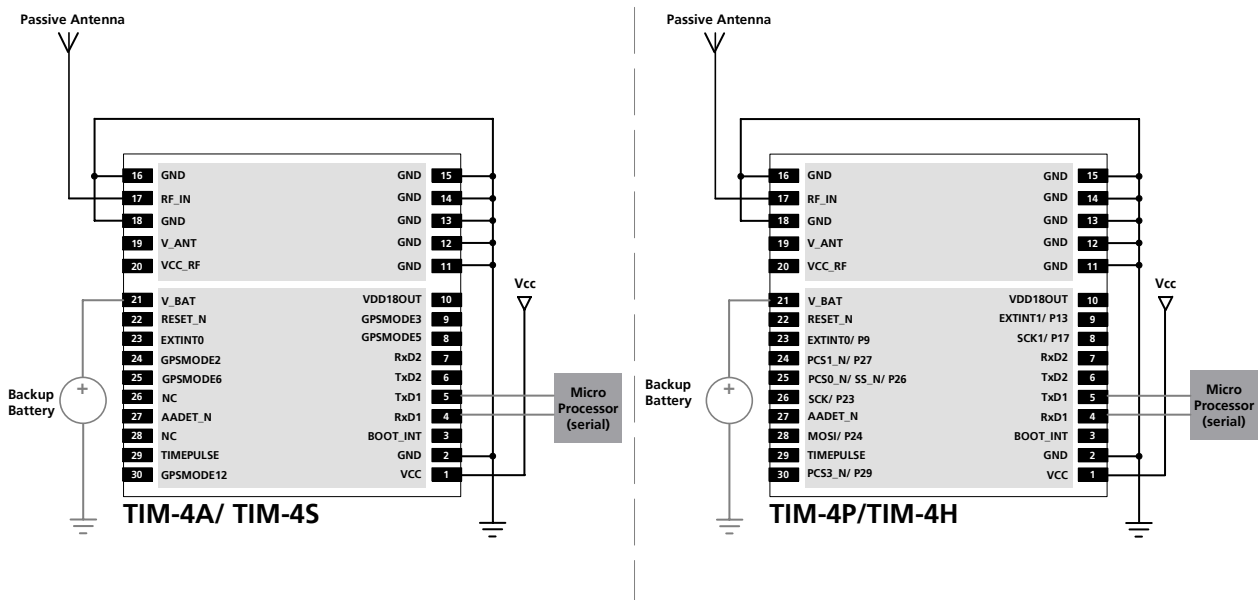

Figure 38: Passive Antenna Design for TIM-4x Receivers

Function	PIN (TIM)	I/O	Description	Remarks
<b>Power</b>				
VCC	1	I	Supply Voltage	Max allowed ripple on VCC=50mVpp
GND	2,11-16,18	I	Ground	Assure a good GND connection to all GND pins of the module, preferably with a large ground plane (for details refer to Section 0)
VDD18OUT	10	O	1.8V supply output	1.8V output voltage reference. Leave open if not used.
VBAT	21	I	Backup voltage supply	It's recommended to connect a backup battery to V_BAT in order to enable Warm and Hot Start features on the receivers. See also Section 4.2.2. Otherwise connect to GND.

Function	PIN (TIM)	I/O	Description	Remarks
<b>Antenna</b>				
RF_IN	17	I	GPS signal input from antenna	The connection to the antenna has to be routed on the PCB. Use a controlled impedance of 50 Ohm to connect RF_IN to the antenna or the antenna connector (for details refer to <i>Section 3.6.5</i> ) Don't supply DC through this pin. Use <b>V_ANT</b> pin to supply power.
V_ANT	19	I	Antenna Bias voltage	Connect to <b>GND</b> if Passive Antenna is used. If an active Antenna is used, add a 10R resistor (see 4.3.3.2) in front of <b>V_ANT</b> input to the Antenna Bias Voltage or <b>VCC_RF</b> for short circuit protection or use the antenna supervisor circuitry (see 4.3.3.2).
VCC_RF	20	O	Output Voltage RF section	Can be used to power an external active antenna ( <b>VCC_RF</b> connected to <b>V_ANT</b> ). The max power consumption of the Antenna must not exceed the datasheet specification of the module (see also 4.3.3). Leave open if not used.
AADET_N	27	I	Active Antenna Detect	Signal pin for optional antenna supervisor circuitry (see 4.3.3.2). Leave open if not used.
<b>Serial Port</b>				
The serial interface is 3V CMOS and 5V TTL compatible. For other voltage levels use the appropriate level shifters.				
TxD1	5	O	Serial Port 1	3V
RxD1	4	I	Serial Port 1	5V tolerant serial port input. Internal pull-up resistor to <b>V_BAT</b> . Leave open if not used. <b>Note</b> Don't use an external pull up resistor.
TxD2	6	O	Serial Port 2	3V
RxD2	7	I	Serial Port 2	5V tolerant serial port input. Internal pull-up resistor to <b>V_BAT</b> . Leave open if not used. <b>Note</b> Don't use an external pull up resistor.
<b>System</b>				
BOOT_INT	3	I	Boot mode	Do not connect on TIM-4A and TIM-4S receivers.
RESET_N	22	I	Hardware Reset (Active Low)	Leave open if not used. Do not drive high. See also <i>Section 4.9.2</i> .
TIMEPULSE	29	O	Timepulse Signal	Configurable Timepulse signal (one pulse per second by default). Leave open if not used. See also <i>Section 4.7.1</i> .
EXTINT0	23	I	External Interrupt	External Interrupt Pin to wake up receiver in FixNOW™ sleep mode. See also <i>Section 4.2.7.1</i> and 4.9.4 for further information. Internal pull-up resistor to <b>V_BAT</b> <sup>5</sup> . Leave open if not used.
GPSPMODE2 <sup>6</sup> / PCS1_N/ P27	24	I/O	GPIO/ GPSPMODE Pin	<b>TIM-4A/ TIM-4S:</b> GPSPMODE Pin; leave open if default configuration is used. Refer to <i>Section 4.8.2</i> for further information.  <b>TIM-4H / TIM-4P:</b> GPIO Pin; leave open if not used. The General Purpose I/O (GPIO) can only be programmed with the ANTARIS®4 Software Customization Kit, please refer to the <i>SCK Manual [8]</i> when intending to use of the GPIO's of the receiver.
GPSPMODE5/ SCK1/ P17	8	I/O		
GPSPMODE6/ PCS0_N/ SS_N/ P26	25	I/O		
GPSPMODE12/ PCS3_N/ P29	30	I/O		
GPSPMODE3/ EXTINT1/ P13/	9	I/O		
NU / SCK/ P23	26	I/O	GPIO / NC	<b>TIM-4A/ TIM-4S:</b> Not connected; leave open. <b>TIM-4H / TIM-4P:</b> GPIO Pin; leave open if not used
NU/ MOSI/ P24/	28	I/O		

Table 6: Pin-out TIM-4x

<sup>5</sup> Do not pull up as it may increase your Battery Backup Current.

<sup>6</sup> Pull to **GND** to achieve Normal Sensitivity Mode setting at startup.



### 3.4 NEO-4S Design

For a minimal Design with NEO-4S, the following function and pins have to be considered:

- Connect the Power supply to VCC.
- Assure a optimal ground connection to all ground pins
- Connect the antenna to RF\_IN over a matching 50 Ohm micro strip.
- If an active antenna shall be connected to NEO, make sure to add an inductor for the antenna bias voltage as shown in section 4.3.3.1 and follow the layout recommendations in section 3.6.6.
- Connect pins 8 and 9 together.
- If you need Hot- or Warmstart in your application, connect a Backup Battery to V\_BAT
- Decide whether the TIMEPULSE option is required in your application and connect the appropriate pins on your module

This is a minimal setup for a PVT GPS receiver with NEO-4S. Now check about special functions and design requirements in *Table 7*.

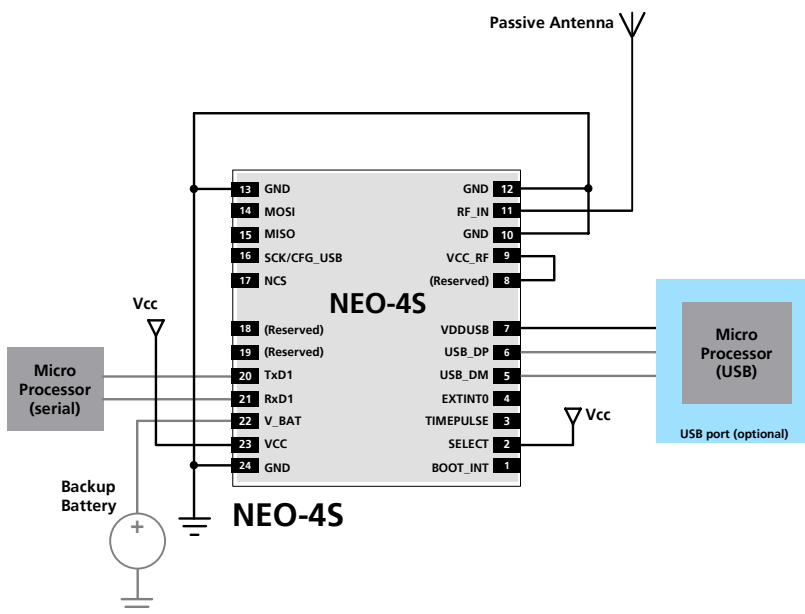

Figure 39: Passive Antenna Design for NEO-4S Receivers

Standard Function				Remarks
No	Name	I/O	Description	
1	BOOT_INT	I	Boot mode	Leave open
2	SELECT		Mode Selector Pin	The <b>SELECT</b> pin allows selection between using the default configuration (Battery Backup RAM) or configuration storage in an external EEPROM (see also section 4.8). Connect to <b>VCC</b> if default configuration is desired. Connect <b>GND</b> if external EEPROM is used. Never leave this pin open. <b>Note:</b> The meaning of pin 16 ( <b>SCK / CFG_USB</b> ) depends on the status of the <b>SELECT</b> pin.
3	TIMEPULSE	O	Time pulse (1PPS)	Configurable Timepulse signal (one pulse per second by default). Leave open if not used. See also <i>Section 4.7.1</i> .
4	EXTINT0	I	External Interrupt Pin	External Interrupt Pin to wake up receiver in FixNOW™ sleep mode. See also <i>Section 4.2.7.1</i> and <i>4.9.4</i> for further information. Internal pull-up resistor to <b>V_BAT</b> <sup>7</sup> . Leave open if not used.
5	USB_DM	I/O	USB Data	USB1.1 bidirectional communication pin. To be fully compliant with USB standard follow the schematic recommendation in <i>Section 4.4.2</i> .
6	USB_DP	I/O	USB Data	
7	VDDUSB	I	USB Supply	To use the USB interface connect this pin to 3.0 – 3.6V. See also <i>Section 4.4.2</i> . If no USB serial port used connect to GND.
8	(Reserved)	I	Reserved	Pins 8 and 9 <b>have</b> to be connected. VCC_RF can also be used to power an external active antenna.
9	VCC_RF	O	Output Voltage RF section	
10	GND	I	Ground	Assure a good <b>GND</b> connection to all <b>GND</b> pins of the module, preferably with a large ground plane (for details refer to <i>Section 0</i> )
11	RF_IN	I	GPS signal input	The connection to the antenna has to be routed on the PCB. Use a controlled impedance of 50 Ohm to connect RF_IN to the antenna or the antenna connector (for details refer to <i>Section 3.6.5</i> )
12	GND	I	Ground	Refer to pin 10.
13	GND	I	Ground	Refer to pin 10.
14	MOSI	O	SPI MOSI	Leave open if SPI interface is not used. Contact u-blox for more information about the SPI interface.
15	MISO	I	SPI MISO	
16	SCK / CFG_USB	O/I	SPI Clock / USB Power Mode	The function of pin 16 depends on the status of the <b>SELECT</b> pin: <ul style="list-style-type: none"> <li><b>If SELECT pin is connected to VCC:</b> Pin 16 is a configuration input, which defines the USB Power Mode. Connect to <b>GND</b> for Bus-Powered USB interface. Leave open if USB interface Self-Powered</li> <li><b>If SELECT pin is connected to GND:</b> Pin 16 is internally connected to the SCK (SPI clock signal). Contact u-blox for more information about the SPI interface.</li> </ul>
17	NCS	O	SPI chip select	Leave open if SPI interface is not used. Contact u-blox for more information about the SPI interface.
18	(Reserved)	I		Leave open
19	(Reserved)	I	NC	Leave open
20	TxD1	O	Serial Port 1	3V Level
21	RxD1	I	Serial Port 1	5V tolerant serial input. Internal pull-up resistor to <b>V_BAT</b> . Leave open if not used. <b>Note</b> Don't use an external pull up resistor.
22	V_BAT	I	Backup voltage supply	It's recommended to connect a backup battery to <b>V_BAT</b> in order to enable Warm and Hot Start features on the receivers. See also <i>Section 4.2.2</i> . Otherwise connect to <b>GND</b> .
23	VCC	I	Supply voltage	Max allowed ripple on <b>VCC</b> =50mVpp
24	GND	I	Ground	Refer to pin 10.

Table 7: Pin-out NEO-4S

<sup>7</sup> Do not pull up as it may increase your Battery Backup Current.

## 3.5 Layout Design-In Checklist for ANTARIS® 4

Follow this checklist for your Layout design to get an optimal GPS performance.

### Layout optimizations (Section 3.6)

- ❑ Is the GPS module placed according to the recommendation in Section 3.6.2?
- ❑ Have you followed the Grounding concept (see Section 0)?
- ❑ Keep the micro strip as short as possible.
- ❑ Add a ground plane underneath the GPS module to reduce interference.
- ❑ For improved shielding, add as many vias as possible around the micro strip, around the serial communication lines, underneath the GPS module etc.
- ❑ Only for LEA-4M and NEO-4S: Has the optional inductor for the (active) antenna bias voltage been routed according to the recommendation in section 3.6.6?

### Calculation of the micro strip (Section 3.6.5)

- ❑ The micro strip must be 50 Ohms and it must be routed in a section of the PCB where minimal interference from noise sources can be expected.
- ❑ In case of a multi-layer PCB, use the thickness of the dielectric between the signal and the 1st **GND** layer (typically the 2nd layer) for the micro strip calculation.
- ❑ If the distance between the micro strip and the adjacent **GND** area (on the same layer) does not exceed 5 times the track width of the micro strip, use the "Coplanar Waveguide" model in AppCad to calculate the micro strip and not the "micro strip" model.

### 3.6 Layout

GPS signals at the surface of the Earth are about 15dB below the thermal noise floor. Signal loss at the antenna and the RF connection must be minimized as much as possible. When defining a GPS receiver layout, the placement of the antenna with respect to the receiver, as well as grounding, shielding and jamming from other digital devices are crucial issues and need to be considered very carefully.

#### 3.6.1 Footprint

This section provides important information enabling the design of a reliable and sensitive GPS system.

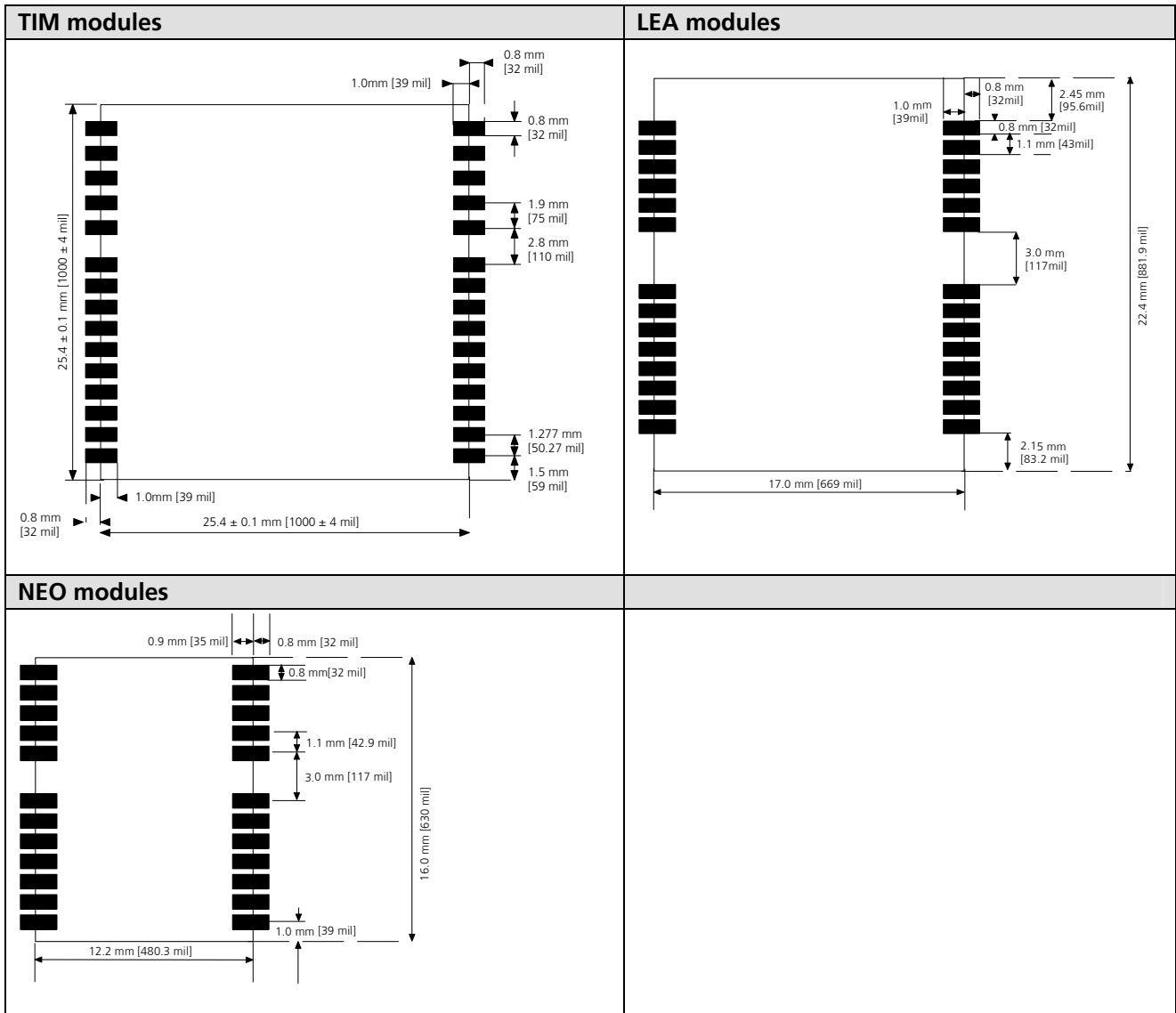
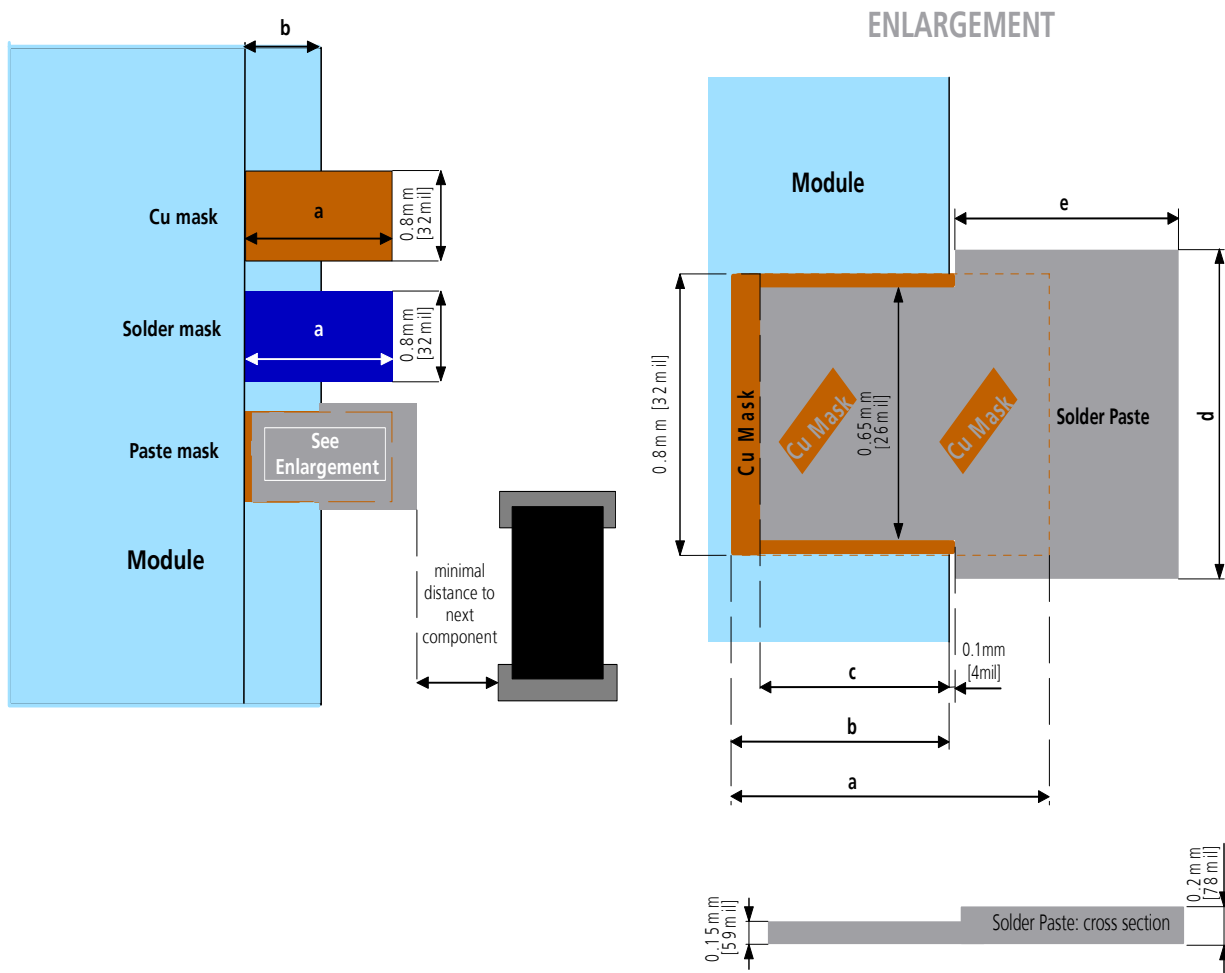

**Figure 40: Recommended footprint**

### 3.6.2 Paste Mask

Figure 41 and Table 8 demonstrate the recommended positioning of Cu, Solder and Paste Masks, as well as the suggested distances. Note that these are recommendations only and not specifications. The exact geometry, distances and solder paste volumes must be adapted to the specific production processes (e.g. soldering etc.) of the customer.

To improve the wetting of the half via it is recommended to reduce the amount of paste mask under the module and to increase the amount of paste mask outside the module by using a step stencil and exceeding the paste mask beyond the Cu Mask as shown in Figure 41. If a step stencil is not used it is still recommended to employ the same volume of solder paste **outside** the module to attain the desired level of wetting. This will have to be done by modifying the shape of the paste mask outside the module.



**Figure 41: Solder and paste mask with enlargement showing positioning and cross section of underlying solder paste**

Dimension	TIM-4x	LEA-4x	NEO-4S
a	1.8mm [70mil]	1.8mm [70mil]	1.7mm [66mil]
b	1.0mm [39mil]	1.0mm [39mil]	0.9mm [35mil]
c	0.65mm [26mil]	0.65mm [26mil]	0.65mm [26mil]
d	0.9mm [35mil]	0.8mm [32mil]	0.8mm [32mil]
e	1.3mm [51mil]	1.5mm [59mil]	1.5mm [59mil]

**Table 8: Paste Mask Dimensions for TIM-4x, LEA-4x and NEO-4S**

**Note** The exact geometry, distances, stencil thicknesses, step heights and solder paste volumes must be adapted to the specific production processes (e.g. soldering etc.) of the customer.

### 3.6.3 Placement

The placement of the ANTARIS<sup>®</sup>4 GPS Receiver on the PCB is very important to achieve maximum GPS performance. The connection to the antenna must be as short as possible to avoid jamming into the very sensitive RF section.

Make sure that RF critical circuits are clearly separated from any other digital circuits on the system board. To achieve this, position the receiver digital part towards your digital section of the system PCB.

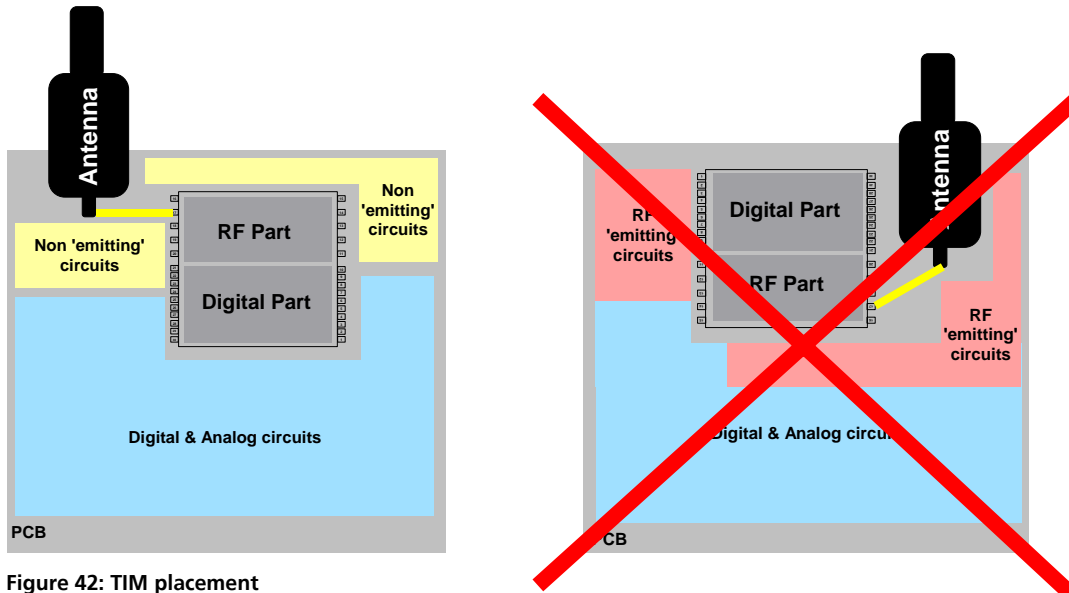

Figure 42: TIM placement

### 3.6.4 Antenna Connection and Grounding Plane Design

ANTARIS<sup>®</sup>4 can be either connected to a passive patch antenna or an active antenna. The antenna RF connection is on the PCB and connects the **RF\_IN** pin with the antenna feed point or the signal pin of the connector, respectively. *Figure 43* illustrates connection to a typical five-pin RF connector. One can also see the improved shielding for digital lines according to the discussion in *Section 1.6.3*. Depending on the actual size of the ground area, additional vias should be placed in the outer region. In particular, the edges of the ground area should be terminated with a dense line of vias.

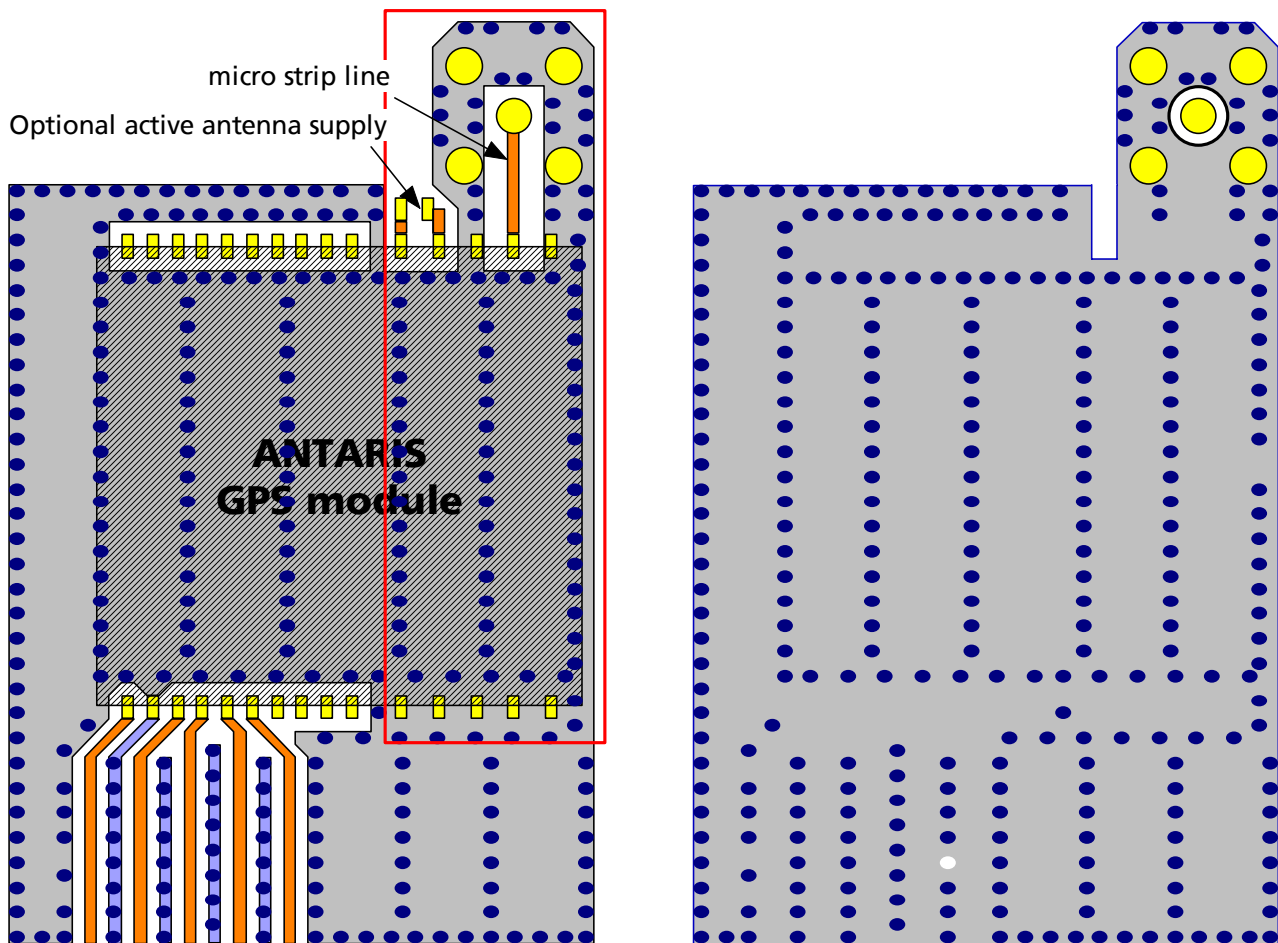

Figure 43: Recommended layout for TIM-xx

As seen in *Figure 43*, an isolated ground area is created around and below the RF connection. This part of the circuit has to be kept as far away from potential noise sources as possible. Make sure that no signal lines cross or vias of signal traces show up at the PCB surface underneath the area surrounded by the red rectangle. Also, the ground plane should be free from digital supply return currents in this area. On a multi layer board, the whole layer stack below the RF connection should be free of digital lines. This is because even a solid ground plane provides only limited isolation.

The impedance of the antenna connection has to match the 50 Ohm impedance of the receiver. To achieve an impedance of 50 Ohms, the width  $W$  of the micro strip has to be chosen depending on the dielectric thickness  $H$ , the dielectric constant  $\epsilon_r$  of the dielectric material of the PCB and on the build-up of the PCB (see *Section 3.6.5*). *Figure 44* shows two different builds: A 2 Layer PCB and a 4 Layer PCB. The reference ground plane is in both designs on layer 2 (red). Therefore the effective thickness of the dielectric is different.

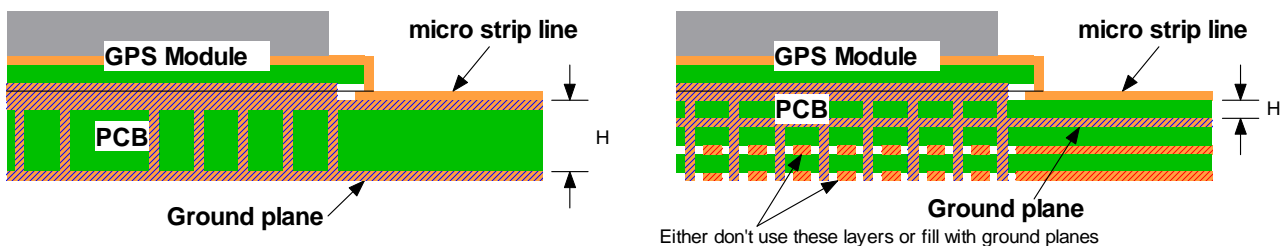
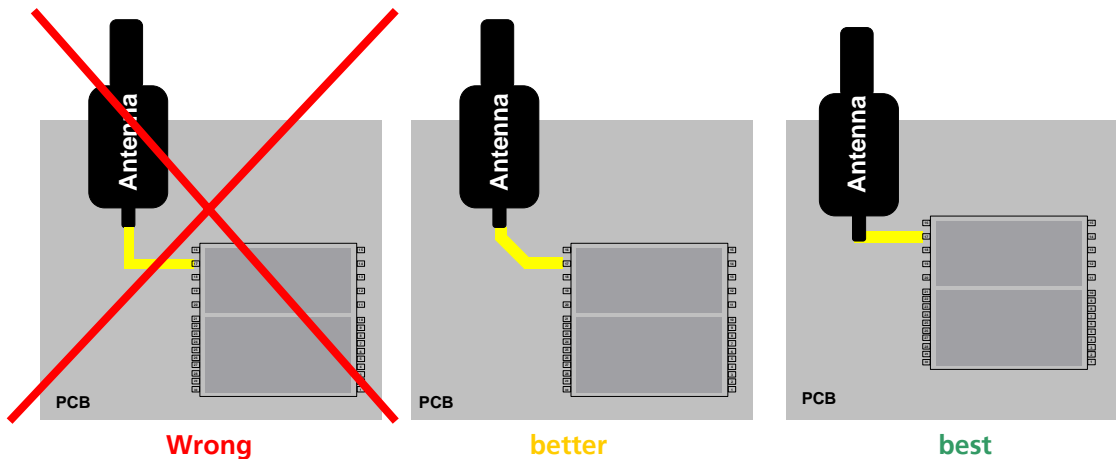

Figure 44: PCB build-up for Micro strip line. Left: 2-layer PCB, right: 4-layer PCB

General design recommendations:

- The length of the micro strip line should be kept as short as possible. Lengths over 2.5 cm (1 inch) should be avoided on standard PCB material and without additional shielding.
- Distance between micro strip line and ground area on the top layer should at least be as large as the dielectric thickness.
- Routing the RF connection close to digital sections of the design should be avoided.
- To reduce signal reflections, sharp angles in the routing of the micro strip line should be avoided. Chamfers or fillets are preferred for rectangular routing; 45-degree routing is preferred over Manhattan style 90-degree routing.



- Routing of the RF-connection underneath the receiver should be avoided. The distance of the micro strip line to the ground plane on the bottom side of the receiver is very small (some 100  $\mu\text{m}$ ) and has huge tolerances (up to 100%). Therefore, the impedance of this part of the trace cannot be controlled.
- Use as many vias as possible to connect the ground planes.
- In order to avoid reliability hazards, the area on the PCB under the receiver should be entirely covered with solder mask. Vias should not be open.

### 3.6.5 Antenna Micro Strip

There are many ways to design wave-guides on printed circuit boards. Common to all is that calculation of the electrical parameters is not straightforward. Freeware tools like AppCAD from Agilent or TXLine from Applied Wave Research, Inc. are of great help. They can be downloaded from [www.agilent.com](http://www.agilent.com) and [www.mwoffice.com](http://www.mwoffice.com).

The micro strip is the most common configuration for printed circuit boards. The basic configuration is shown in *Figure 45* and *Figure 46*. As a rule of thumb, for a FR-4 material the width of the conductor is roughly double the thickness of the dielectric to achieve 50 Ohms line impedance.

For the correct calculation of the micro strip impedance, one does not only need to consider the distance between the top and the first inner layer but also the distance between the micro strip and the adjacent GND plane on the same layer

**Note:** Use the Coplanar Waveguide model for the calculation of the micro strip.



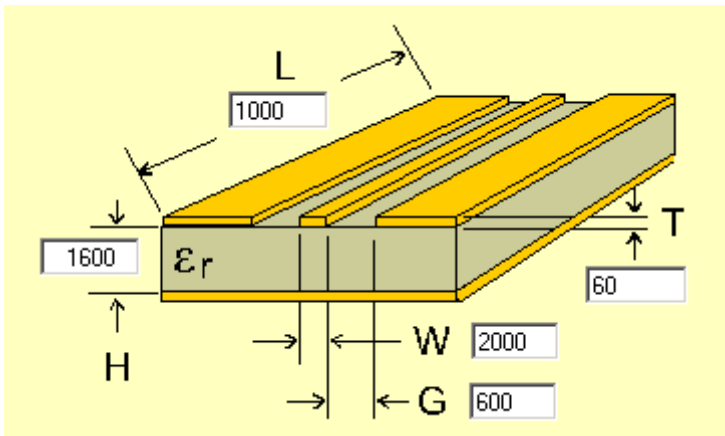

Figure 45: Micro strip on a 2-layer board (Agilent AppCAD Coplanar Waveguide)

Figure 45 shows an example of a 2-layer FR4 board of 1.6 mm thickness and a 35µm (1 ounce) copper cladding. The thickness of the micro strip is comprised of the cladding (35µm) plus the plated copper (typically 25µm). Figure 46 depicts an example of a multi layer FR4 board with 18µm (½ ounce) cladding and 180µ dielectric between layer 1 and 2.

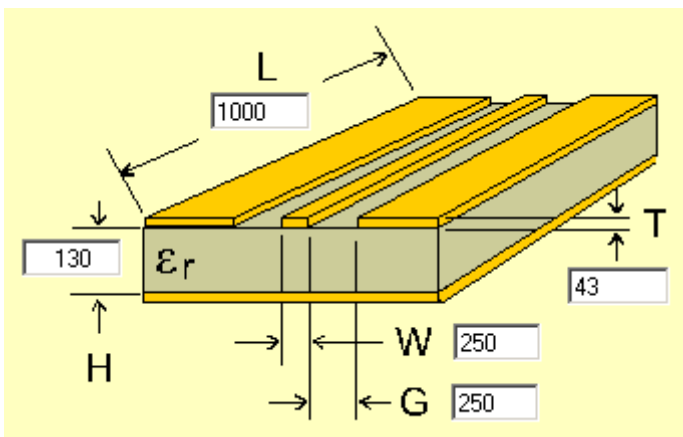

Figure 46: Micro strip on a multi layer board (Agilent AppCAD Coplanar Waveguide)

### 3.6.6 Antenna Bias Voltage on NEO-4S and LEA-4M

NEO-4S and LEA-4M do not provide the antenna bias voltage for active antennas at the RF\_IN pin. It is therefore necessary to provide this voltage outside the module via an inductor as indicated in Figure 62. For optimal performance, it is important to place the inductor as close to the microstrip as possible. Figure 47 illustrates the recommended layout and also shows an example of how it should not be done.

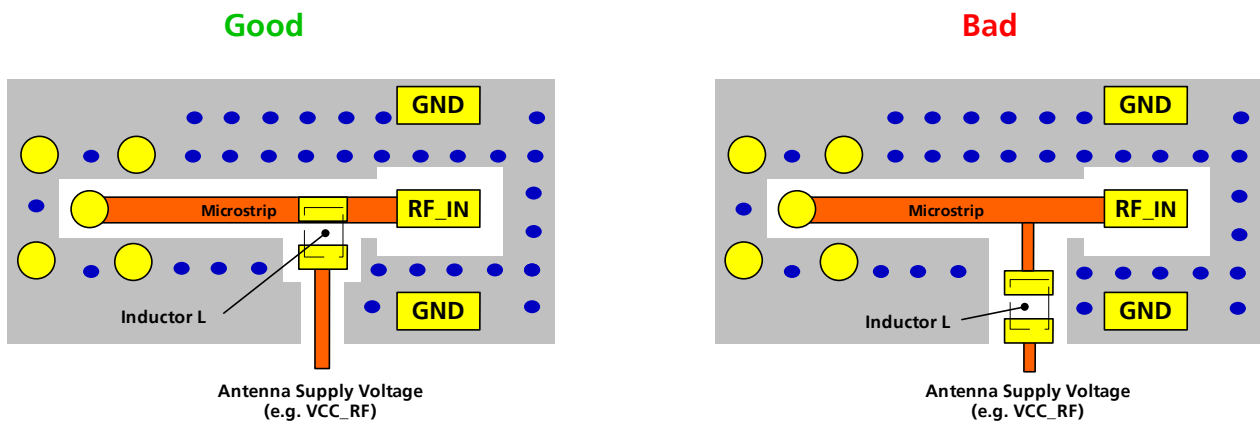

Figure 47: Recommended layout for connecting the antenna bias voltage for LEA-4M and NEO-4S

# 4 Receiver Description

## 4.1 Overview

A4

The ANTARIS®4 GPS Module is a self-contained receiver for the Global Positioning System (GPS). The complete signal processing chain from antenna input to serial output is contained within a single component.

The height of 3mm (~120mil) and small size makes it the ideal GPS solution for applications with stringent space requirements. This type of package makes expensive RF cabling obsolete. The RF input is available directly on a pin, the ANTARIS®4 GPS Module is SMT solderable and can be handled by standard pick and place equipment.

The ANTARIS®4 GPS Receiver provides up to two serial ports, which can handle NMEA, UBX proprietary data format and differential GPS correction data (RTCM) and a USB device port (only LEA-4x and NEO-4x modules)

### 4.1.1 Block Schematic

A4

The ANTARIS®4 GPS receiver is divided into two distinct, separately shielded sections. The smaller section is the RF- Section, the larger section contains the baseband.

The RF section contains the low noise amplifier (LNA) ATR0610, the SAW bandpass filter, the RF-IC ATR0601 and the GPS crystal. The ATR0601 uses a single IF sub-sampling scheme with an analogue IF of 96.764 MHz, a sampling frequency of 23.104 MHz, and a resulting digital IF of 4.348 MHz.

The baseband section contains the digital circuitry comprised of the ATR062x baseband processor, the RTC crystal and additional elements as such optional FLASH memory where specified.

The two sections are connected by a number of digital signals: Control signals from the digital part switch between different power states of the RF section. The 23.104 MHz clock is supplied to the digital part as well as the 1.5 bit quantized IF signal. Another status signal reports the status of the antenna bias input to the baseband processor. Finally, after rigorous filtering, power is supplied from the digital part to the RF part.

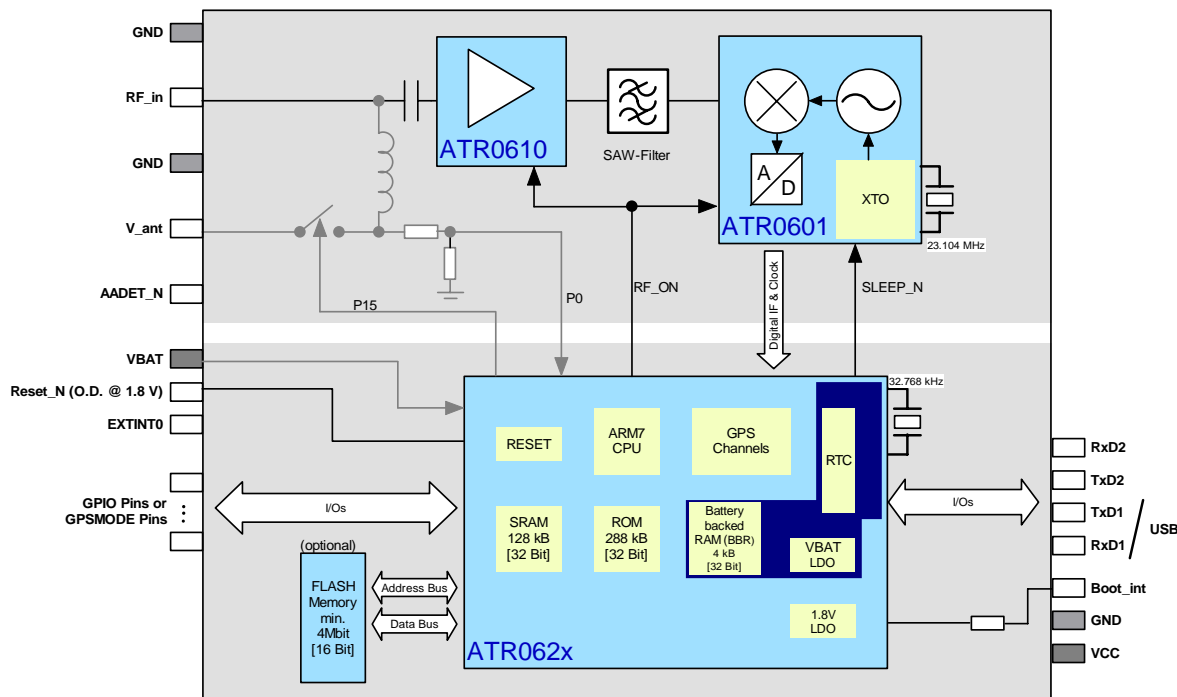

Figure 48: Hardware Block Schematic

#### 4.1.1.1 The RF Section explained

The RF section fulfills four major tasks:

- Low Noise Amplification of the antenna signal  
The built-in Low noise amplifier, LNA (ATR0610) provides the initial amplification of the antenna signal. It has a very low noise figure and is the first pre-amplification stage. The performance of this part determines the noise performance of the whole receiver.
- Filtering of the antenna signal  
Since the architecture of the ATR0601 does not use an image reject mixer for power saving reasons, a SAW filter at the RF input is needed to suppress the image frequency.
- Frequency conversion of the input signal to a frequency suited for digital processing.
- Sampling of the analog signal to obtain a digital bit stream  
An automatic gain control (AGC) loop is used in front of the A/D-converter to maintain an optimum load for the converter input and maximize the dynamic range of its 1.5 bit resolution. The A/D converter output signal is sampled using the sampling clock, yielding a synchronous time-discrete representation of the input signal.
- Generation of the main clock frequency.  
An integrated crystal oscillator (XTO or TCXO) generates the main clock frequency of 23.104 MHz.

In order to ease connection of active antennas, a bias-T is integrated into most modules. It provides the ability to supply a DC current into the **V\_ANT** pin, which is internally fed into the **RF\_IN** pin.

#### 4.1.1.2 The Digital Section explained

The core component of the digital section is the highly integrated baseband processor ATR0621. It contains an ARM7 CPU, the GPS correlator hardware, RAM and ROM, battery backup RAM, RTC, reset generator and two voltage regulators. All Programmable receivers contain additional FLASH memory.

The crystal required for the RTC is also integrated into all GPS modules.

#### Digital Interface:

- All GPS Modules have at least two communication interfaces (USB or serial ports).
- Pin **EXTINT0** can be used to generate direct software interrupts from outside of the GPS module.
- The **TIMEPULSE** pin provides a highly configurable time pulse signal, synchronized to UTC or GPS time.
- The **BOOT\_INT** pin is used to start the GPS Receiver in Boot Mode (e.g. to recover in case of corrupt firmware images due to failed firmware updates).
- The **RESET\_N** pin can be used either as output to initialize external logic upon power up of the GPS module or as input to initiate a hardware reset of the GPS module from external hardware.

ROM based receivers have **GPSMODE** pins to define a customized startup configuration.

## 4.2 Power Management

### 4.2.1 Connecting Power

The ANTARIS®4 GPS Receiver basically has two power supply pins, **VCC** and **VBAT**. For LEA modules there is an additional pad power supply pin **VDDIO** that defines the IO voltage levels. *Figure 50* shows the internal connections of the power supply network.

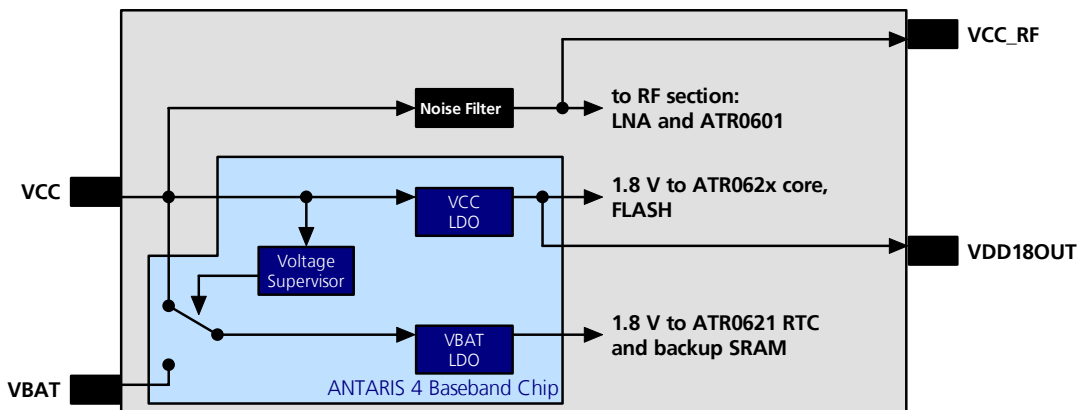

Figure 50: Power supply concept

#### 4.2.1.1 VCC - Main Power

Main power supply is fed through the **VCC** pin. During operation, the current drawn by the ANTARIS®4 GPS Receiver can vary by some orders of magnitude, especially, if low-power operation modes are enabled. It is important that the system power supply circuitry is able to support the peak power (see datasheet for specification) for a short time. In order to dimension a battery capacity for certain application the sustained power figure shall be used.

- ☞ **Note** A GPS receiver is sensitive to ripples on the power supply voltage. The max ripple must not exceed 50 mV peak to peak. It is strongly recommended to design a low-resistance connection from the voltage regulator to the VCC supply pin of the module. Any resistive or inductive losses in this path may result in an undesired increase of VCC ripple voltage at the module. It is also a good idea to place a large capacitor, e.g. 10µF, close to the VCC pin of the module.

### 4.2.2 Backup Battery

In case of a power failure on pin **VCC**, real-time clock and backup RAM are supplied through pin **V<sub>bat</sub>**. This enables the ANTARIS®4 GPS receiver to recover from power failure with either a Hotstart or a Warmstart (depending on the duration of **VCC** outage) and to maintain the configuration settings. If no Backup Battery is connected, the receiver performs a Coldstart at power up.

- ☞ **Note** If no backup battery is available connect the V<sub>bat</sub> pin to GND.

As long as Vcc is supplied to the ANTARIS®4 GPS Receiver, the backup battery is disconnected from the RTC and the backup RAM in order to avoid unnecessary battery drain (see *Figure 52*). Power to RTC and BBR is supplied from Vcc in this case.

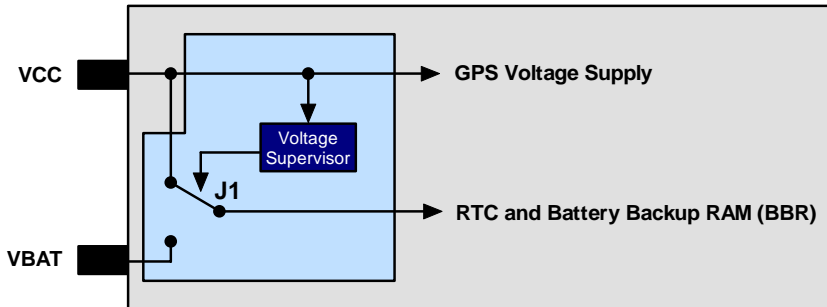

**Figure 52: Backup Battery and Voltage**

Before Vcc is supplied for the first time, switch J1 *Figure 52* is not initialized. In this case increased battery drain might occur if the backup battery is connected to the **V\_Bat** pin. The battery drain will drop to the specified level as soon as Vcc is applied the first time.

**Note** It's advised to connect the backup battery while Vcc is on or – if not possible – power up the module for a short time (e.g. 1s) ASAP after connecting the backup battery in order to avoid excessive battery drain.

### 4.2.3 Avoiding increased current in low power modes

Special attention has to be paid to the pins RxD1, RxD2, EXTINT0 and EXTINT1. These 4 pins can be used to wake up from FixNOW sleep modes. For that reason these pins are powered from backup supply, even if VCC is turned off. Since these pins have internal pull-up resistors, current (e.g. 15µA) flows through these internal resistors if the pin is driven low. To avoid this current, which increases the sleep or backup currents by an order of magnitude, there are different possibilities:

- Leave these pins open.
- Pull them to a "HIGH" while the receiver is in sleep or backup mode
- Make sure the outputs, which drive these pins, are in high-impedance state while the receiver is in sleep or backup mode.

**Note** When the system is turned off, a current may flow from backup battery through the pull-up resistors of these 4 pins (RxD1, RxD2, EXTINT0 and EXTINT1) through ESD protection diodes of your circuit (i.e. micro-controller).

## 4.2.4 Power Saving Modes

## 4.2.5 Operating Modes

The ANTARIS<sup>®</sup>4 GPS technology offers ultra-low power architecture with built-in autonomous power save functions. The receiver uses Autonomous Power Management to minimize the power consumption at any given time. The CPU clock is geared down every time the full CPU performance is not needed. Even at very low clock speeds, the CPU can still respond to interrupts and gear up CPU clock quickly if required by the computing task. The software frequently makes use of this feature to reduce average power consumption. Furthermore, the clock supply to unused peripheral on-chip blocks is shut down by software.

The ANTARIS<sup>®</sup>4 GPS Technology defines the following Operating Modes:

Operating Modes	Description
<b>Continuous Tracking Mode (CTM)</b>	The Continuous Tracking Mode is optimized for position accuracy. This mode is optimized for minimal power consumption based on the <b>Autonomous Power Management</b> . The Continuous Tracking Mode is the default setting of the ANTARIS <sup>®</sup> 4 GPS receiver. There is no specific configuration needed.
<b>Power Saving Mode:</b>	
<b>FixNOW<sup>™</sup> Mode (FXN)</b>	FixNOW <sup>™</sup> Mode allows an application to request a navigation solution as required. It includes additional power save functions and is the best mode for any mobile, tracking unit application where low power consumption is of primary consideration. This mode can be configured for different application requirements. <b>Note</b> Not suitable for DR enabled GPS receivers!

Table 9: Operating Modes

### Choosing an Operation Strategy

The ANTARIS<sup>®</sup>4 GPS receivers offer different features to optimize the overall power consumption. The receiver always runs in the most economic power state and switches off internal modules that are not in use. (E.g. if no input and/or output protocol is selected for a serial port, the respective gates on the ASIC will not be clocked and the SPI is switched off by default).

**Note** The update rate influences the power consumption and position accuracy.

**Note** Initial acquisition and reacquisition needs maximum power as specified in the datasheet. The power consumption is about 5% higher during initial acquisition compared to typical operation (tracking) status.

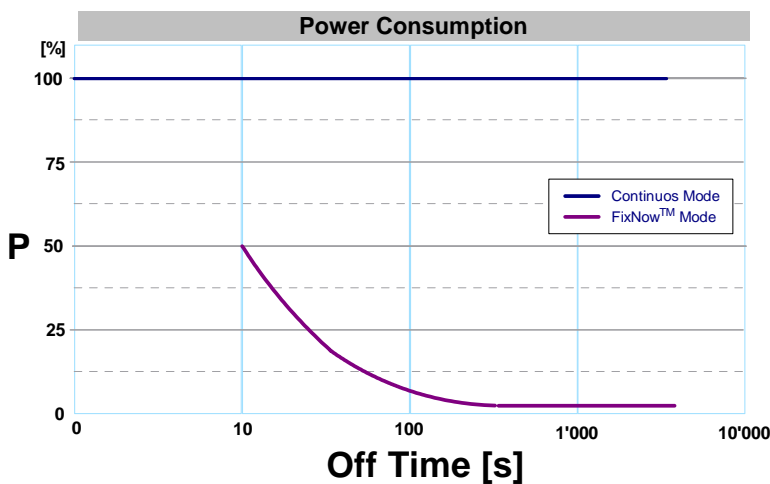

Figure 53: Power Consumption with FixNOW Mode

Requirements	Recommended Operation Mode
Maximum Accuracy	<i>Continuous Tracking Mode (CTM)</i> ; Default configuration
Periodic position fixes (< 10s) Power consumption is of minor concern	<i>Continuous Tracking Mode (CTM)</i> It's possible to adjust the measurement period and the message rate of the serial output messages.
Periodic position fixes (< 10s) Reduced Power consumption required	<i>Continuous Tracking Mode (CTM)</i> It's possible to optimize power consumption by disabling not required features (refer to <i>Section 4.2.6.1</i> )
Periodic position fixes (>10s) Minimal power consumption	<i>FixNOW™ Mode (FXN)</i> Set the on- and off-time of the receiver as desired.
Position fix required on demand 'Time to first fix' as short as possible	<i>FixNOW™ Mode (FXN)</i> Set the on-time to 35s and off-time of to <1800s.
Position fix required on demand Minimal power consumption	<i>FixNOW™ Mode (FXN)</i> Set the on-time to 0s and off-time as required by the application.
Position fix required on demand 'Time to first fix' may exceed 25 seconds. Minimal power consumption	<i>FixNOW™ Mode (FXN)</i> Set the on- and off-time of the receiver as desired.

Table 10: Choosing an operation strategy

## 4.2.6 Continuous Tracking Mode

The Continuous Tracking Mode continuously tracks GPS signals and computes position fixes. With the integrated Autonomous Power Management, the receiver optimizes the power consumption continuously.

**Note** Continuous Tracking Mode is the default operation mode.

### 4.2.6.1 Reducing the Current Consumption in Continuous Tracking Mode

Table 11 lists various options to further reduce the power consumption of ANTARIS®4 GPS receivers in Continuous Tracking Mode.



SBAS	Disabling SBAS (WAAS, EGNOS) reduces the current consumption by up to 3mA (depending on the number of visible SBAS satellites).
Update Rate	Reducing the update rate from 1 Hz to 0.2 Hz (1 position in 5 seconds) results in a current saving of about 0.6 mA. Increasing the update rate from 1 Hz to 4 Hz increases the current consumption by 2 to 3 mA
Power supply voltage	Lowering Vcc from 3.3V to 2.85V reduces the current consumption by approx. 1mA
Idling serial ports	<p>Disabling a serial port (e.g. port 2), which is not connected to the application, reduces the current consumption by approximately 0.4mA.</p> <p>By sending a CFG-PRT message with Protocol in and Protocol out set to 'none', the port can be completely disabled.</p>

UBX - CFG (Config) - PRT (Ports)

Target:

Protocol in:

Protocol out:

Baudrate:

**Table 11: Means to reduce Power Consumption in Continuous Tracking Mode**

### 4.2.7 Power Saving Modes (FixNOW™ Mode, FXN)

In FixNOW™ Mode (FXN), the receiver will shut down automatically if there is no GPS signal and wake up at predefined intervals in order to acquire GPS PVT Data. FixNOW™ Mode also allows the GPS receiver to be set into Sleep State to further reduce the power consumption of the receiver.

A restart of the receiver can be compared to a reacquisition scenario; therefore the same sensitivity level applies when a receiver wakes up from any FixNOW™ Off State.

**Note** Do not use FixNOW™ on DR enabled GPS Receivers (e.g. LEA-4R/TIM-4R)

#### 4.2.7.1 Power States

In the Continuous Tracking Mode (CTM) the receiver is always in the Full Power State. In FixNOW™ Mode (FXN) the receiver may use different power states influencing the function and power consumption of the receiver.

Power States	Modes		Description
	CTM	FXN	
Full Power State	✓	✓	This is the state during satellite acquisition, reacquisition and tracking. All active sections are powered.
Sleep State	-	✓	Can be selected in FXN Mode when no navigation solution is required or possible. The receiver can be woken up via EXTINT interrupts or serial port command
Backup State	-	✓	Can be selected in FXN Mode when no navigation solution is required or possible.
CPU Only	-	-	Not available by default.

**Table 12: Overview Power States**

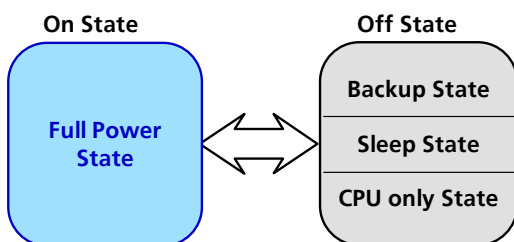

**Figure 54: On State - Off State**

### Full Power State (On State)

In Full Power State all components of the ANTARIS<sup>®</sup>4 chipset are powered through pin **VCC**. This is the standard operation mode. Depending on CPU load, activity of the peripheral hardware and external load on the I/Os, the actual supply current requirement may vary significantly.

### Sleep State (Off State)

Within this mode the CPU is powered and the receiver can be woken up with a request on the serial communication interface or an external interrupt.

If no computations need to be done, further power saving can be achieved by shutting down the clock. Nevertheless, the system can still respond to interrupt sources and wake up again.

If voltage supply is always present at pin **VCC**, no backup battery is needed. The sleep state is useful if the system is idle and waiting for user input or similar events. The real time clock – as it remains active and running – can also schedule the sleep state to wake up the receiver after a pre-defined period of time.

☞ **Note** When operating an Antaris<sup>®</sup>4 receiver over the USB Port use the Backup State rather than Sleep State.

### Backup State (Off State)

Battery Backup State is a selectable power save state in FXN mode. Contrary to Sleep State, only the RTC and the battery backed up SRAM are powered. This results in even further reduced power consumption. The receiver is woken-up and goes through a reset cycle when the preprogrammed off time expires or upon hardware reset. This means, configuration changes not saved to battery backup RAM (BBR) or Flash will be lost after waking up from the Backup State (see also section 4.8).

### CPU Only State (Off State)

In a custom application where the ARM7 processor of the GPS receiver is needed but no GPS functionality is required, the entire GPS part of the system can be shut down while e.g. no position output and no satellite tracking is required and the CPU is executing the custom code. This way the customer has access to 100% of the CPU power. (The CPU clock is still supplied from the RF section to the baseband processor.)

The RTC is still powered to allow fast startup when GPS positioning is required.

☞ **Note** The Not available by default.

#### 4.2.7.2 Position upon Request

The receiver can be configured to calculate a PVT solution upon request during the off time by:

- The UBX - RXM (Receiver Manager) – POSREQ (Position Request) Message
- **EXTINT0** Pin

To configure the FixNOW<sup>™</sup> Mode (FXN) use the UBX–CFG–FXN message. Use the UBX–CFG–RXM message to enable or disable FixNOW<sup>™</sup> Mode.

The optimal settings of the receiver depend on the requirements of the application such as required update rate or maximum response time.

#### 4.2.7.3 Waking up ANTARIS<sup>®</sup>4 GPS Receiver with external signals

If the ANTARIS<sup>®</sup>4 GPS Receiver has entered Sleep State and the power supply at pin **VCC** is present, various triggers can wake up the receiver:

Wakeup conditions	
Pin	Trigger
EXTINT0	Rising edge
RxD1 or RxD2	Falling edge

**Table 13: Possibilities to wakeup the receiver**

- ☞ **Note** When waking up a receiver from sleep- or backup state with a serial message (RxD1 or RxD2), a number (at least 8) of 0xFF characters shall be send prior to the RXM-POSREQ message. Otherwise the first bytes may get lost.
- ☞ **Note** When waking up the ANTARIS®4 GPS Receiver by **EXTINT0** a position will be calculated.

During off state driving **RESET\_N** low can wake the receiver up. If the receiver configuration has not been saved in BBR, the receiver will loose the actual configuration and revert to previous configuration.

#### 4.2.7.4 Waking up the ANTARIS®4 GPS Receiver by RTC

The ANTARIS®4 GPS Receiver has an internal RTC, which is used to set a timeout to wake-up the receiver without any external signal. This is used in the FixNOW™ Mode (FXN) (see *Section 4.2.7*).

- ☞ **Note** The RTC wake-up timeout can only be set internally by the FixNOW™ function. There is no external or manual access to the wake up timeout.

#### 4.2.7.5 Active Antenna Power Control with FixNOW™

The FixNOW™ mode controls the Power Supply for the active antenna connected to the **RF\_IN** pin. The voltage supply will be shut down when the receiver goes to Off State.

#### 4.2.7.6 Functional Overview

The FXN mode has several parameters to optimize the GPS- and Power-Performance to meet specific user application requirements:

Parameter	Description
<b>T_on [s]</b>	Time the receiver stays on after achieving the first position fix with the flag 'position within limits' set. If T_on is set to 0s, the receiver will shut down after the first valid fix as soon as the RTC is calibrated. If a new ephemeris is needed to achieve the defined accuracy, the receiver will automatically increase the "startup acquisition time T_acq".
<b>T_off [s]</b>	Time the receiver stays in Off State
<b>Base TOW [s]</b>	Alignment of T_acq (start-up) to GPS Time of Week.
<b>T_acq [s]</b>	Time the receiver tries to acquire SV before going to Off State, if SV acquisition is not successful.
<b>T_acq_off [s]</b>	Time the receiver stays in Off State, when SV acquisition was not successful.
<b>T_reacq [s]</b>	Time the receiver tries to reacquire as soon as a sky obstruction happens and no 2D or 3D fix is possible.
<b>T_reacq_off [s]</b>	Time the receiver stays in Off State, after reacquisition was not successful.

**Table 14: FXN mode parameter description**

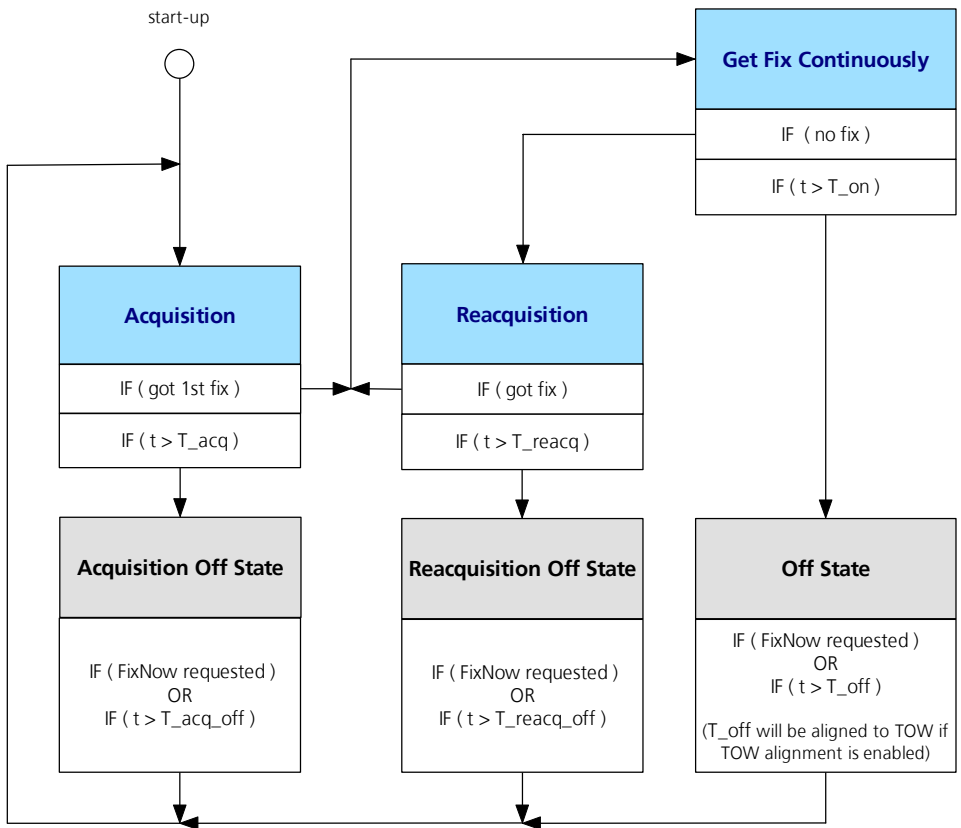

**Figure 55: Simplified FXN state diagram**

#### 4.2.7.7 FXN without On/Off Time

In this mode, the receiver will – as long as there is good GPS coverage – never turn itself off. If there is loss of signal, or if there is no signal at power-up, the receiver will time out and go to an Off State for a predefined period.

**T<sub>acq</sub>** (acquisition time) and **T<sub>acq\_off</sub>** (off time after an unsuccessful acquisition) define the startup behavior after an off time. This can be an initial startup or a subsequent startup after an unsuccessful reacquisition procedure.

**T<sub>reacq</sub>** (reacquisition time) and **T<sub>reacq\_off</sub>** configure the reacquisition procedure after a GPS signal loss. If the GPS signal is lost, the receiver tries during **T<sub>reacq</sub>** to reacquire the signal. If this fails, the receiver goes to Off State for **T<sub>reacq\_off</sub>**. After this time the receiver will startup as defined above.

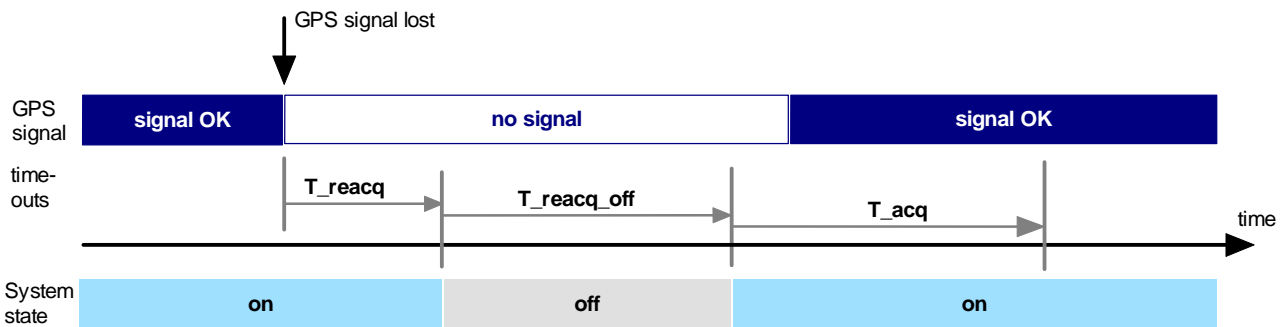

Figure 56: FXN without On/Off Time, GPS signal is lost in Full Power State

Example			
Use on/off time	Disabled		
T <sub>on</sub> [s]	Not used	T <sub>off</sub> [s]	Not used
Absolute align	Disabled	Base TOW [s]	Not used
T <sub>acq</sub> [s]	60	T <sub>acq_off</sub> [s]	120
T <sub>reacq</sub> [s]	5	T <sub>reacq_off</sub> [s]	60
Operation			
As long as there is good GPS coverage, the receiver will keep running.			
If there is loss of signal for at least 5 seconds, the receiver will shut down for 60 seconds. After that off time, the receiver will try to find the signal for 60 seconds. If that fails it will shut down for another 120 seconds.			

Table 15: Example settings FXN without On/Off Time

#### 4.2.7.8 FXN with On/Off Time

In contrast to using FXN without On/Off Time the receiver will only stay on for **T<sub>on</sub>** after an initial fix has been achieved and switch to Off State for **T<sub>off</sub>** afterwards.

If there is no GPS signal when the receiver wakes up, the receiver will try to acquire a fix as usual for **T<sub>acq</sub>**. If this is not successful the receiver goes to Off State for **T<sub>acq\_off</sub>**.

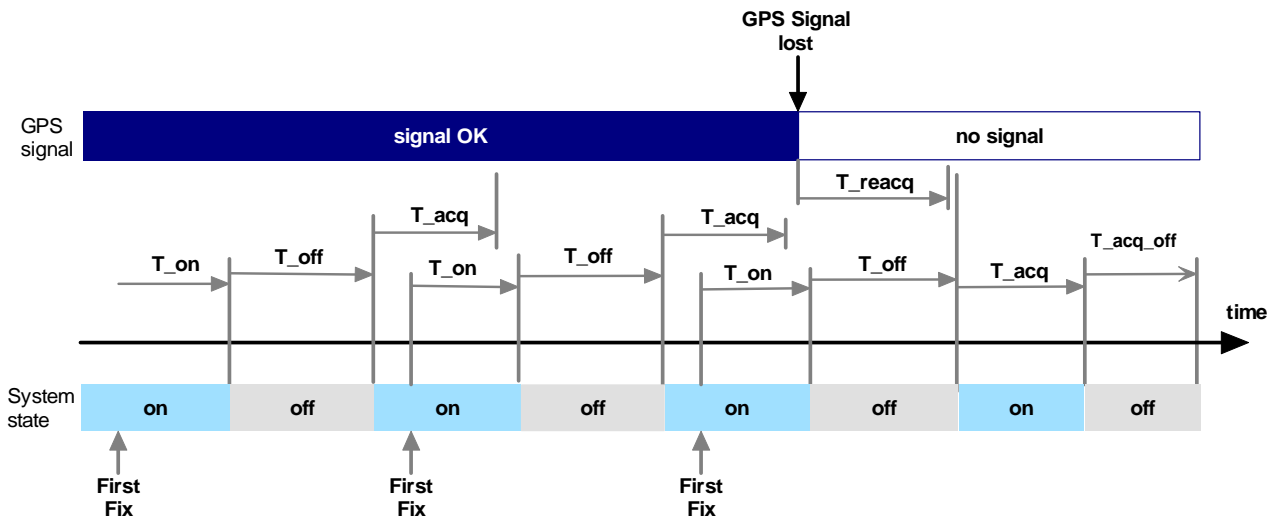

Figure 57: FXN with On/Off Time, GPS signal is lost in Full Power State

If the signal is lost during the on time, the receiver starts to reacquire the SV for **T<sub>reacq</sub>**, if this is not successful the receiver goes to Off State for **T<sub>reacq\_off</sub>**. If **T<sub>on</sub>** is reached before **T<sub>reacq</sub>** is expired, the receiver goes to Off State for **T<sub>off</sub>**. After this time the GPS will start to acquire SV as a normal start up.

**Note** If **T<sub>reacq</sub>** is longer than **T<sub>on</sub>** a reacquisition timeout will never happen, because **T<sub>on</sub>** overrules **T<sub>reacq</sub>**.

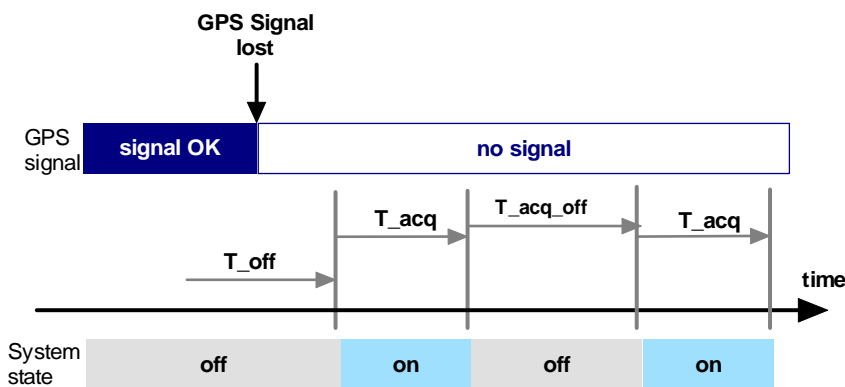

Figure 58: FXN with On/Off Time, GPS signal is lost in Full Power State

Example			
Use on/off time	Enabled		
T_on [s]	0 (= one valid fix)	T_off [s]	60
Absolute align	Disabled	Base TOW [s]	Not used
T_acq [s]	60	T_acq_off [s]	120
T_reacq [s]	5	T_reacq_off [s]	60
Operation			
As long as there is good GPS coverage, the receiver will perform PVT solutions for <b>T_on</b> , then switches to the sleep state for <b>T_off</b> (60 seconds).			
If – during the on time - there is loss of signal for <b>T_reacq</b> (5 seconds, before <b>T_on</b> expires), the receiver will shut down for <b>T_reacq_off</b> (60 seconds). After that off time, the receiver will try to find the signal for <b>T_acq</b> (60 seconds). If that fails it will shut down for another <b>T_acq_off</b> (2 minutes).			

Table 16: Example settings FXN with On/Off Time

**Note** If **T\_on** is set to 0s, the receiver will enter Off State as soon as the Position Accuracy is below the **P Accuracy Mask** (see also Section 4.6.8.1). For an improved accuracy, increase **T\_on** by a few seconds.

#### 4.2.7.9 FXN with On/Off Time and absolute Alignment

This mode’s operation is equivalent to “**FXN With On/Off Time**”, but the receiver will align on- and off time to an absolute TOW-based (GPS time) time grid after the first successful fix.

The parameter **T\_off** has a slightly different meaning compared to the non-aligned FixNOW™ mode. It is the time grid unit rather than the off time. **T\_on** is still the time the receiver operates in Full Power State and output valid position fixes. **Base TOW** is the parameter, which shifts the time grid relative to TOW 0.

The TOW count begins with the value 0 at the beginning of the GPS week (transition period from Saturday 23:59:59 hours to Sunday 00:00:00 hours).

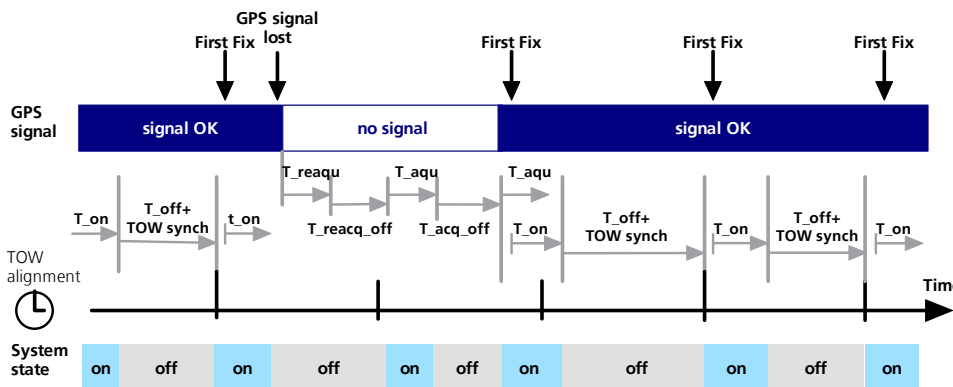

Figure 59: FXN With On/Off Time and absolute alignment after a first fix

**Note** If the division of number of seconds a week (604800) by **T\_off** isn't an integer value, at the end of the week the Off Time be shorter than **T\_off**. This is caused by the synchronization of the wake up time to TOW.

Example			
Use on/off time	Enabled		
T_on [s]	0 (= one valid fix)	T_off [s]	86'400 (=24 hours)
Absolute align	Enabled	Base TOW [s]	43'200 (=12 hours)
T_acq [s]	60 (=1 minute)	T_acq_off [s]	120 (=2 minutes)
T_reacq [s]	5	T_reacq_off [s]	60
Operation			
The receiver will wake up once a day at 12:00 GPS and perform one position fix.			

Table 17: Example settings FXN With On/Off Time and absolute Alignment

**Note** If **T\_on** is set to 0s, the receiver will enter Off State as soon as the Position Accuracy is below the **P Accuracy Mask** (see also *Section 4.6.8.1*). For an improved accuracy, increase **T\_on** by a few seconds.

The FixNOW™ (FXN) screen in u-center AE software holds three templates (example parameter sets) based on the FixNOW™ Mode (FXN), providing an insight to the capability of this feature.

1. **Mobile Device Set:** Setting with continuous GPS fixes as long as there is good sky view, but low power settings otherwise (using **FXN without On/Off Time**).
2. **Asset Tracking Unit Set:** Sleeping unit but allows position information on request (using **FXN with On/Off Time**).
3. **Schedule Fix Set:** As Asset Tracking Unit but with position information aligned to a fix time (using **FXN with On/Off Time and absolute Alignment**).
4. **User Set:** Is selected as soon as any of the predefined settings are changed

### 4.2.8 Externally Controlled Power Management

In case of external power control, it's necessary to monitor the Real Time Clock Status in UBX – MON (Status) – HW (Hardware Status). The Real Time Clock Status indicates whether the internal RTC is calibrated or not. A calibrated RTC is required to achieve minimal startup time (hot start).

If the RTC is not calibrated the receiver would typically start up only within 20-30 s even if ephemeris data is available.

## 4.3 Antenna and Antenna Supervisor

ANTARIS®4 GPS Receivers get the L1 band signals from GPS satellites at a nominal frequency of 1575.42 MHz. The RF signal is connected to the **RF\_IN** pin.

ANTARIS®4 GPS modules can be connected to passive or active antennas.

**Note** For ANTARIS®4 GPS receivers, the total preamplifier gain (minus cable and interconnect losses) must not exceed 50 dB. Total noise figure should be below 3 dB.

The ANTARIS®4 Technology supports either a short circuit protection of the active antenna or an active antenna supervisor circuit (open and short circuit detection). For further information refer to *Section 4.3.2*.

### 4.3.1 Passive Antenna

A design using a passive antenna requires more attention regarding the layout of the RF section. Typically a passive antenna is located near electronic components; therefore care should be taken to reduce electrical



'noise' that may interfere with the antenna performance. For further information about Antenna designs refer to Section 3.4.

Passive antennas do not require a DC bias voltage and can be directly connected to the RF input pin **RF\_IN**. Sometimes, they may also need a passive matching network to match the impedance to 50 Ohms.

**Note** Some passive antenna designs present a DC short to the RF input, when connected. If a system is designed with antenna bias supply AND there is a chance of a passive antenna being connected to the design, consider a short circuit protection.

**Note** All ANTARIS<sup>®</sup>4 receivers have a built-in LNA required for passive antennas.

### 4.3.2 Active Antenna

Active antennas have an integrated low-noise amplifier. They can be directly connected to **RF\_IN**. If an active antenna is connected to **RF\_IN**, the integrated low-noise amplifier of the antenna needs to be supplied with the correct voltage through pin **V\_ANT** or an external inductor. Usually, the supply voltage is fed to the antenna through the coaxial RF cable. Active antennas require a power supply that will contribute to the total GPS system power consumption budget with additional 5 to 20 mA typically. Inside the antenna, the DC component on the inner conductor will be separated from the RF signal and routed to the supply pin of the LNA (see Figure 60).

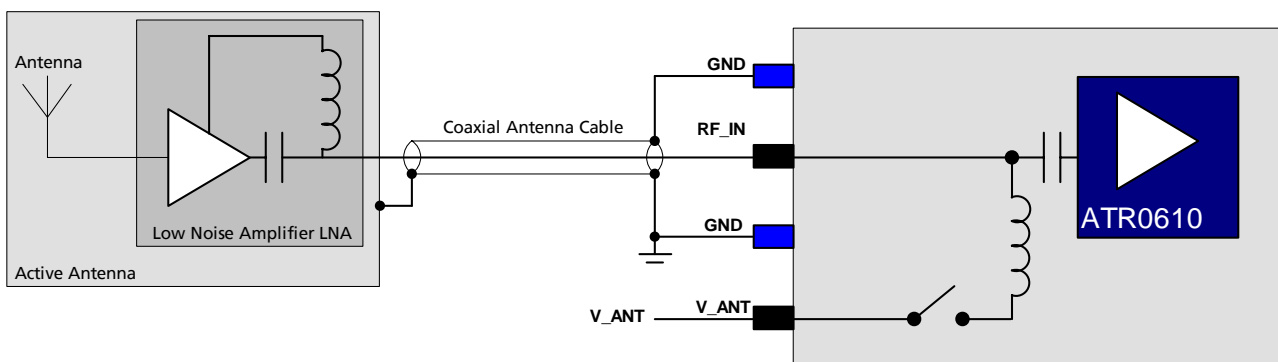

**Figure 60: Active antenna biasing**

Generally an active antenna is easier to integrate into a system design, as it is less sensitive to jamming compared to a passive Antenna. But an active Antenna must also be placed far from any noise sources to have a good performance.

**! Warning** Antennas should only be connected to the receiver when the receiver is not powered. Do not connect or disconnect the Antenna when the ANTARIS<sup>®</sup>4 GPS receiver is running as the receiver calibrates the noise floor on power-up. Connecting the antenna after power-up can result in prolonged acquisition time.

**! Warning** Never feed supply voltage into RF\_IN. Always feed via V\_ANT or an external inductor .

**Note** To test GPS signal reacquisition, we recommend physically blocking the signal to the antenna, rather than disconnecting and reconnecting the receiver.

### 4.3.3 Active Antenna Bias Power

This section only applies to TIM-4x and LEA-4x receivers with the exception of LEA-4M. For LEA-4M and NEO-4S refer to Section 4.3.3.1.

There are two ways to supply the bias voltage to pin **V\_ANT**. It can be supplied externally (please consider the datasheet specification) or internally. For Internal supply, the **VCC\_RF** output must be connected to **V\_ANT** to supply the antenna with a filtered supply voltage. However, the voltage specification of the antenna has to match the actual supply voltage of the ANTARIS®4 GPS Receiver (e.g. 3.0 V).

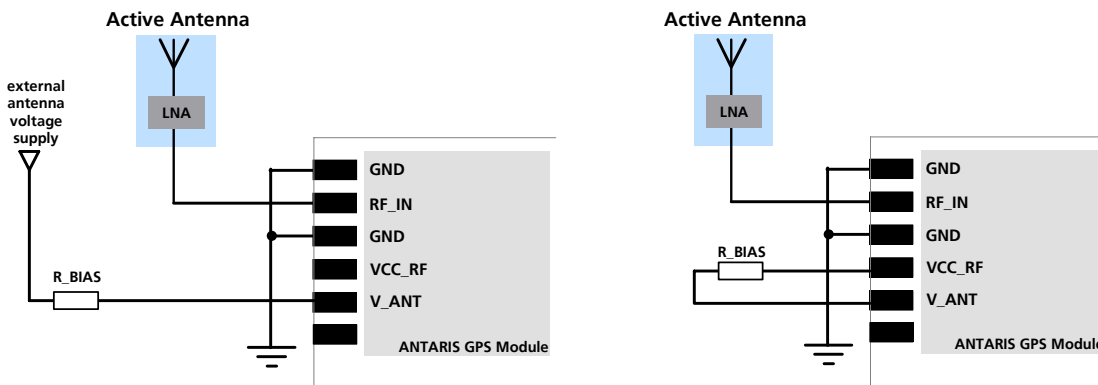

Figure 61: Supplying Antenna bias voltage

Since the bias voltage is fed into the most sensitive part of the receiver, i.e. the RF input, this supply should be virtually free of noise. Usually, low frequency noise is less critical than digital noise with spurious frequencies with harmonics up to the GPS band of 1.575 GHz. Therefore, it is not recommended to use digital supply nets to feed pin **V\_ANT**.

An internal switch (under control of the ANTARIS®4 GPS software) can shutdown the supply to the external antenna whenever it is not needed. This feature helps to reduce power consumption when the GPS receiver is in Sleep Mode.

#### 4.3.3.1 Antenna Bias Voltage for LEA-4M and NEO-4S

This section only applies to LEA-4M and NEO-4S For all other receivers, refer to Section 4.3.3.

NEO-4S and LEA-4M do not provide the antenna bias voltage for active antennas on the RF\_IN pin. It is therefore necessary to provide this voltage outside the module via an inductor as indicated in Figure 62. u-blox recommends using an inductor from Coilcraft (0402CS-36NX). Alternative parts are feasible if the inductor's resonant frequency matches the GPS frequency of 1575.4MHz.

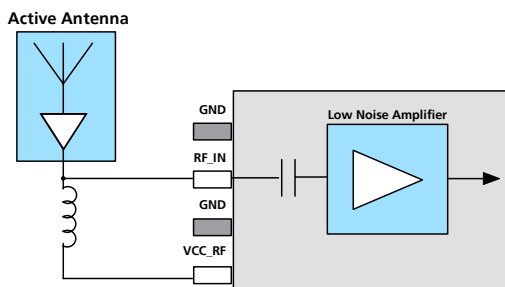

Figure 62: Recommended wiring for active antennas

Passive antennas can directly be connected to the RF\_IN pin of LEA-4M and NEO-4S. No inductor is required in this case.

**Note** Please refer to section 3.6.6 for layout recommendations for the antenna bias voltage inductor.

### 4.3.3.2 Short Circuit Protection

This section only applies to TIM-4x and LEA-4x receivers with the exception of LEA-4M.

If a reasonably dimensioned series resistor **R\_BIAS** is placed in front of pin **V\_ANT**, a short circuit situation can be detected by the baseband processor. If such a situation is detected, the baseband processor will shut down supply to the antenna. For firmware version earlier than 5.00, the voltage supply to the antenna will only be re-established after a hardware reset of the receiver, e.g. after power cycling. For firmware version 5.00 or later the receiver can be configured to attempt to reestablish antenna power supply periodically.

**Note** To configure the antenna supervisor use the UBX-CFG-ANT message. For further information refer to the *ANTARIS®4 Protocol Specification*.

References	Value	Tolerance	Description	Manufacturer
R_BIAS	10 Ω	± 10%	Resistor, min 0.250 W	

**Table 18: Short circuit protection, bill of material**

**Warning** Short circuits on the antenna input without limitation of the current can result in permanent damage to the receiver! Therefore, it's recommended to implement an R\_BIAS in all risk applications, such as situations where the antenna can be disconnected by the end-user or that have long antenna cables.

**Note** An additional R\_BIAS is not required when using a short and open active antenna supervisor circuitry as defined in *Section 4.3.4.1*, as the R\_BIAS is equal to R2.

**Note** This feature is not available for LEA-4M and NEO-4S. However, both modules still output antenna status messages. NEO-4S always reports "ANTSTATUS=OK" whereas LEA-4S will always report "ANTSTATUS=SHORT". Both messages shall be ignored.

### 4.3.4 Active Antenna Supervisor

The ANTARIS®4 GPS Technology provides the means to implement an active antenna supervisor with a minimal number of parts. The antenna supervisor is highly configurable to suit various different applications.

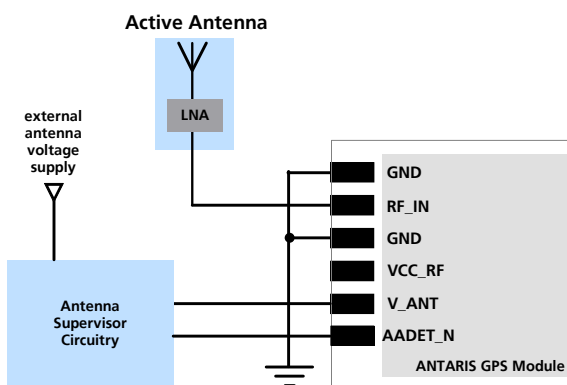

**Figure 63: External antenna power supply with full antenna supervisor**

### 4.3.4.1 Short and Open Circuit Active Antenna Supervisor

This section only applies to TIM-4x and LEA-4x receivers with the exception of LEA-4M.

The Antenna Supervisor can be configured by a serial port message (using only UBX binary message).

When enabled the active antenna supervisor produces serial port messages (status reporting in NMEA and/or UBX binary protocol) which indicates all changes of the antenna circuitry (**disabled** antenna supervisor, antenna circuitry **ok**, **short** circuit, **open** circuit) and shuts the antenna supply down if required.

The active antenna supervisor provides the means to check the active antenna for open and short circuits and to shut the antenna supply off, if a short circuit is detected.

The following state diagram applies. The initial state after power-up is "Active Antenna OK".

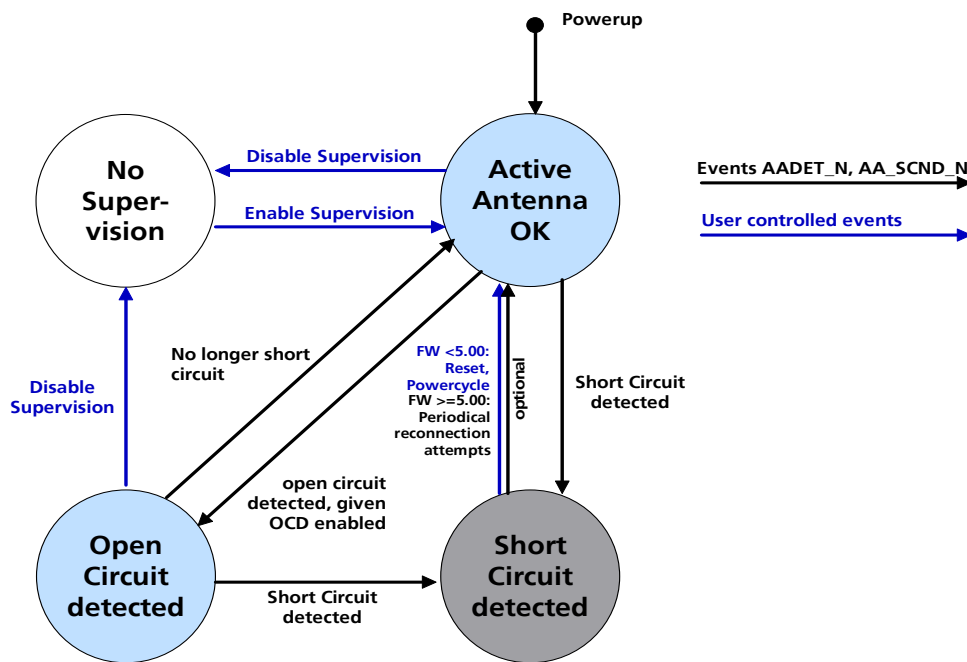
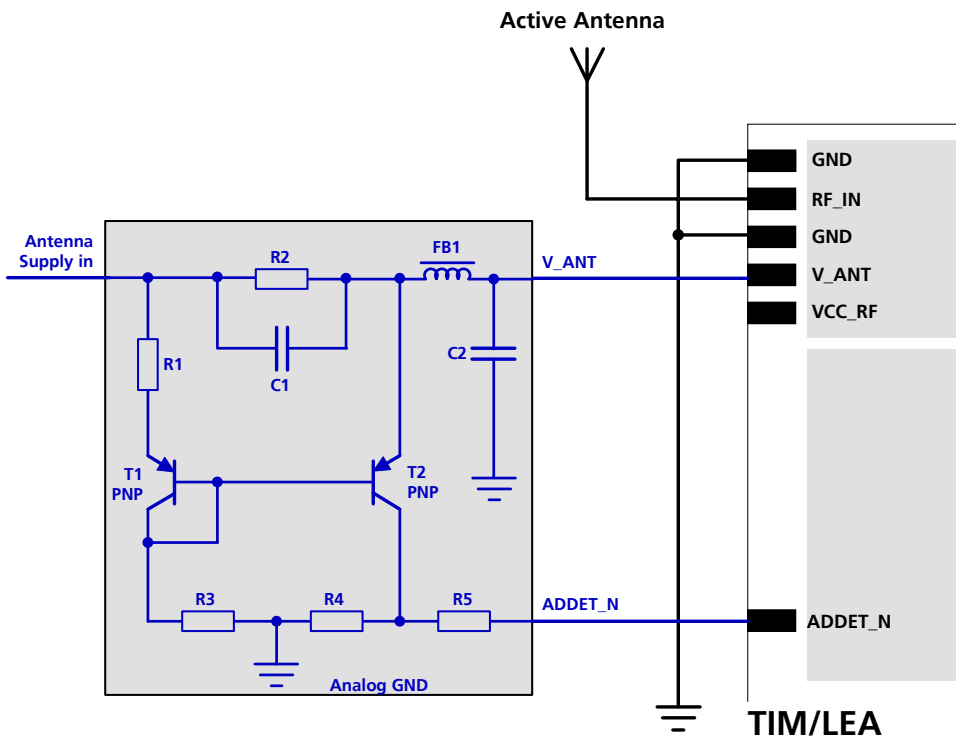

Figure 64: State Diagram of Active Antenna Supervisor

**Note** This feature is not available on LEA-4M and NEO-4S. However, both modules still output antenna status messages. NEO-4S always reports "ANTSTATUS=OK" whereas LEA-4S will always report "ANTSTATUS=SHORT". Both messages should be ignored.



**Figure 65: Schematic of open circuit detection**

AADET\_N is assigned to different pins for TIM-4R and the other variants of TIM-4x. On TIM-4x, AADET\_N is assigned to pin 27 (see Figure 65). On TIM-4R, AADET is assigned to pin 30 since pin 27 is used for the SPI interface. In case of designs, where either a TIM-4x or a TIM-4R shall be populated, a layout for two optional 0-Ohm resistors to pin 27 and 30 shall be provided (see Figure 66).

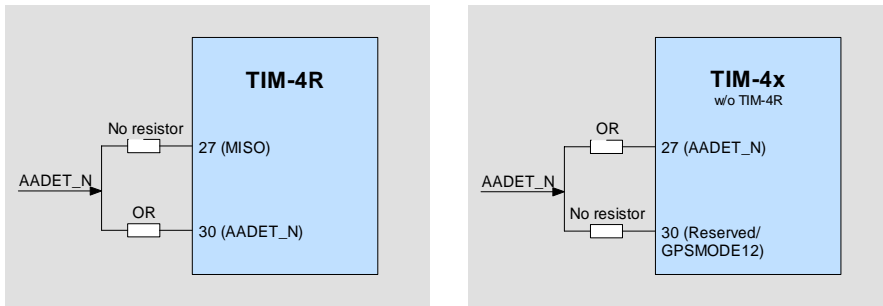

**Figure 66: Connection of "Open Circuit Detection" signal to AADET\_N input**

References	Value	Tolerance	Description	Remarks
C1	2.2 $\mu$ F	$\pm$ 10%	Capacitor, X7R, min 10 V	
C2	100 nF	$\pm$ 10%	Capacitor, X7R, min 10 V	
FB1	600 $\Omega$		Ferrite Bead	e.g. Murata BLM18HD601SN1
R1	56 $\Omega$	$\pm$ 10%	Resistor, min 0.063 W	
R2	10 $\Omega$	$\pm$ 10%	Resistor, min 0.250 W	
R3, R4	5.6 k $\Omega$	$\pm$ 10%	Resistor, min 0.063 W	
R5	0 $\Omega$ or 47 k $\Omega$	$\pm$ 10%	Resistor, min 0.063 W	Use 0 $\Omega$ if antenna voltage supply is <4.5V. Otherwise, use a 47k resistor.
T1, T2			PNP Transistor BC856B	e.g. Philips Semiconductors <sup>8</sup>

**Table 19: Active Antenna Supervisor, bill of material**

### Short Circuit Detection (SCD)

A short circuit in the active antenna pulls **V\_ANT** to ground. This is detected inside the ANTARIS<sup>®</sup>4 GPS module and the antenna supply voltage will be immediately shut down.

**Note** Antenna short detection (SCD) and control is enabled by default.

### Open Circuit Detection (OCD)

The open circuit detection circuit uses the current flow to detect an open circuit in the antenna. The threshold current is at 3-5mA. A current below 3mA will definitely indicate an open circuit. A current above 5mA will definitely indicate no open circuit (values apply for R2=10  $\Omega$ ).

If the current through T2 is large, the voltage drop through R4 and therefore ADDET\_N will be high, indicating an open connection. On the other hand, if the current is small, ADDET\_N will be low.

**Note** On Programmable GPS Modules the antenna open circuit detection (OCD) is disabled by default, on Low Cost modules it's enabled.

### Status Reporting

At startup and on every change of the antenna supervisor configuration the ANTARIS<sup>®</sup>4 GPS module will output a NMEA (\$GPTXT) or UBX (INF-NOTICE) message with the internal status of the antenna supervisor (disabled, short detection only, enabled).

None, one or several of the strings below are part of this message to inform about the status of the active antenna supervisor circuitry (e.g. "ANTSUPERV= AC SD OD PdoS").

Abbreviation	Description
AC	Antenna Control (e.g. the antenna will be switched on/ off controlled by the GPS receiver)
SD	Short Circuit Detection Enabled
OD	Open Circuit Detection Enabled
PdoS	Power Down on short

**Table 20: Active Antenna Supervisor Message on startup (UBX binary protocol)**

<sup>8</sup> Transistors from other suppliers with comparable electrical characteristics may be used.

**Note** To activate the antenna supervisor use the UBX-CFG-ANT message. For further information refer to the *ANTARIS®4 Protocol Specifications [9]*.

Similar to the antenna supervisor configuration, the status of the antenna supervisor will be reported in a NMEA (\$GPTXT) or UBX (INF-NOTICE) message at start-up and on every change.

Message	Description
ANTSTATUS=DONTKNOW	Active antenna supervisor is not configured and deactivated.
ANTSTATUS=OK	Active antenna connected and powered
ANTSTATUS=SHORT	Antenna short
ANTSTATUS=OPEN	Antenna not connected or antenna defective

**Table 21: Active Antenna Supervisor Message on startup (NMEA protocol)**

**Note** The open circuit supervisor circuitry has a quiescent current of approximately 2mA. This current may be reduced with an advanced circuitry, which fulfils the same function as the u-blox suggested circuitry.

## 4.4 Serial Communication

The ANTARIS®4 GPS Technology comes with a highly flexible communication interface. It supports both the NMEA and the proprietary UBX protocol and is able to accept differential correction data (RTCM). It is truly multi-port and multi-protocol capable. Each protocol (UBX, NMEA, RTCM, custom protocol) can be assigned to several ports at the same time (multi-port capability) with individual settings (e.g. baud rate, messages enabled, etc.) for each port. It is even possible to assign more than one protocol (e.g. UBX protocol and NMEA) to a single port (multi-protocol capability), which is particularly useful for debugging purposes.

Use the UBX proprietary messages UBX – CFG (Config) – PRT (Port) to activate a protocol (UBX, NMEA, RTCM) on a port and UBX - CFG (Config) – MSG (Message) to activate a specific message on a serial port and define the output rate (see *ANTARIS®4 GPS Protocol Specifications [9]*). Every protocol can be activated on several ports if required.

### 4.4.1 USART Ports

All TIM-4x, LEA-4S and LEA-4A receivers feature two universal synchronous/asynchronous receiver/transmitters (USART) ports (**RxD1/TxD1** and **RxD2/TxD2**) that can be used to transmit GPS measurements, monitor status information and configure the receiver. All LEA-4P, LEA-4H and LEA-4T receiver feature one USART and one USB serial port.

Using the following functions of the serial port requires the *ANTARIS®4 Software Customization Kit*:

- Synchronous serial interfacing using the additional pins **SCK0 SCK1** and **SCK2** as synchronous serial clocks.
- SPI Interface

All serial interface signals (Port1: **TxD1, RxD1**; Port2: **TxD2, RxD2**) operate on 3V CMOS signal levels. External line transceivers are necessary to provide RS 232 compatible signal levels.

The serial ports consist of a RX- and a TX line. No handshaking- or hardware flow control signals are available. These serial ports operate in asynchronous mode. Supported Baud Rates are:

Possible Asynchronous Serial Interface Configurations		Data bit	Parity bit	Stop bit
Baud rate	4'800 9'600 19'200 38'400 57'600 115'200	8	N	1

**Table 22: USART configuration**

The baud rates can be set individually for each Serial Port. Different baud rates for RX and TX or for different protocols on the same port are not supported.

A normal data transmission (with a configuration of 8 Data bits, No Parity, 1 Stop bit, usually short named '8N1') of a single byte looks as follows:

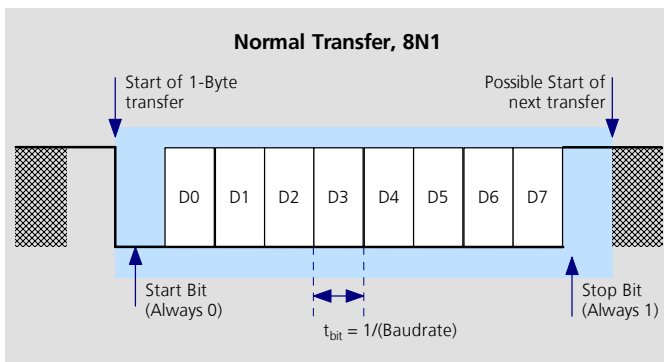

**Figure 67: Definition USART data packets**

#### 4.4.1.1 Error Conditions on USART Ports

Please note that for protocols such as NMEA or UBX, it does not make sense to change the default values of Word Length or Bit Order, since these properties are defined by the protocol, not by the electrical interface.

**Note** If the baud rate is insufficient to transmit all enabled messages, some messages may be discarded and not transmitted. The receiver does not check whether a message will be transmitted completely in the remaining time. Discarded messages won't be transmitted in the next sequence.

#### 4.4.1.2 Autobauding

The user can individually configure each port to use an autobauding mechanism. This mechanism gets active if the receiver indicates an error when receiving data.

- If multiple break conditions are encountered, the baud rate of the serial port is reduced to the next lower standard baud rate
- If the receiver detects multiple framing errors, the baud rate is increased to the next higher standard baud rate.

**Warning** Don't use the u-center AE autobauding feature if the GPS receiver autobauding is enabled.

**Warning** Some serial port cards/adapters frequently generate errors. The u-center autobauding may not work reliably in this case. If you experience frequent errors, please set the baud rate manually.



### 4.4.1.3 SPI Interface

The standard software does not support the SPI interface. SPI is only used on LEA-4R/TIM-4R for connecting the external sensors. It is also used to connect an optional EEPROM to NEO-4S for permanently saving of configuration changes.

### 4.4.2 USB Serial Port (LEA-4x and NEO-4S)

All LEA-4x receivers and NEO-4S feature one USB serial port. It is an alternative to the UART serial ports and can be used not only for communication, but also to power the GPS receiver.

The following configuration settings are supported in UBX – CFG (Config) – USB (Universal Serial Bus)

Parameter	Description
<b>Power Mode</b>	Defines whether the Device draws power over the USB power line (bus powered mode) or whether it has its own power supply (self powered mode).
<b>Automatic reconnection</b>	This flag will automatically initiate a disconnect-reconnection cycle to update the USB device information in the PC's USB port manager.  <b>Note</b> When changing any vendor-, product information or serial number Windows would immediately require the matching driver files.

Table 23: USB Configuration Parameter

**Note** When using USB port together with FixNOW Power saving Mode, choose Backup Mode rather than Sleep Mode as Power Saving Mode.

The USB interface supports two different power modes. In the 'Self Powered Mode' the receiver is powered by its own power supply. **VDDUSB** is used to detect the availability of USB port.

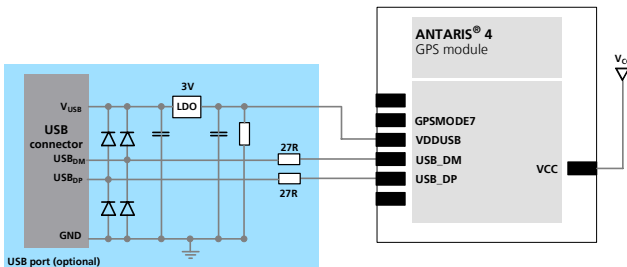

Figure 68: Self Powered USB Mode Schematic

In the 'Bus powered mode' no power supply for the GPS receivers is available. The USB bus supplies power up to 100mA. To achieve a constant **VCC** a LDO is a requirement.

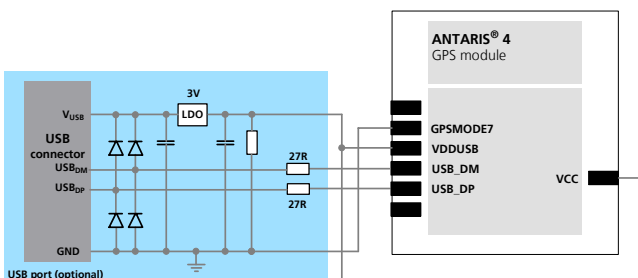

Figure 69: Bus Powered USB Mode Schematic

If USB serial port is not used connect **VDDUSB** to GND and leave **GPSMODE7**, **USB\_DM** and **USB\_DP** open.

**Note** The voltage range for **VDDUSB** is specified from 3.0V to 3.6V, which differs slightly from the specification for **VCC**.

### 4.4.3 UBX Binary Protocol

The u-blox GPS Receivers use a u-blox proprietary protocol to transmit GPS data to a host computer using asynchronous RS232 or USB ports. This proprietary protocol has the following key features:

- Compact. 8 Bit binary data is used
- Checksum protected, using a low-overhead checksum algorithm
- Modular, using a 2-stage Message Identifier (Class- and Message ID)

**Note** UBX protocol offers a greater flexibility and more powerful messages than NMEA protocol. It's optimized to communicate with u-center AE software to get the best performance and optimal debugging.

The ANTARIS<sup>®</sup>4 receiver features a two-stage I/O message and protocol selection procedure for the available serial ports.

1. The RTCM, NMEA or UBX protocol can be enabled or disabled for a given USART port.
2. Messages can be enabled or disabled for each enabled protocol on each port.

For further information please refer to *ANTARIS<sup>®</sup>4 GPS Protocol Specifications [9]*.

#### 4.4.3.1 UBX Packet Structure

A basic UBX packet looks as follows:

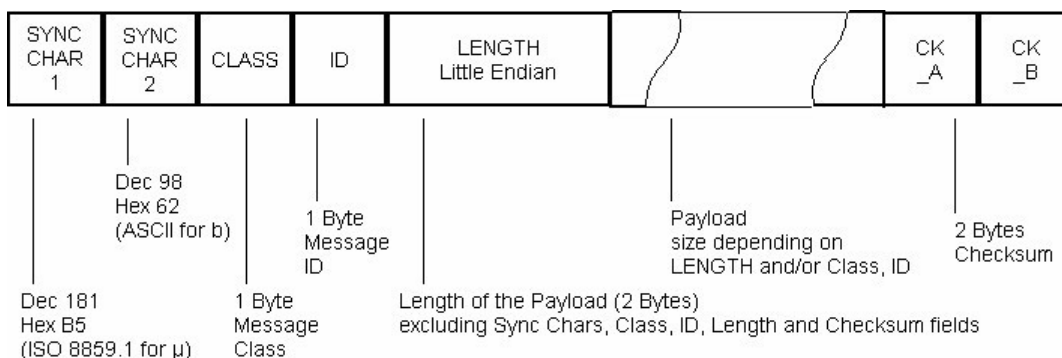

**Figure 70: UBX Protocol Framing**

- Every message starts with 2 Bytes: 0xB5 0x62
- A 1 Byte Class Field follows. The Class defines the basic subset of the message
- A 1 Byte ID Field defines the message that is to follow
- A 2 Byte Length Field is following. Length is defined as being the length of the payload, only. It does not include Sync Chars, Length Field, Class, ID or CRC fields. The number format of the length field is an unsigned 16-Bit integer in Little Endian Format.
- The Payload is a variable length field.
- CK\_A and CK\_B is a 16 Bit checksum whose calculation is defined below.

### 4.4.3.2 UBX Message Class

A Class is a grouping of messages, which are related to each other. The following table gives the short names, description and Class ID Definitions.

Class ID	Class Name	Class No	Description	Examples
NAV	Navigation	0x01	Navigation Results	Position, Speed, Time, Acc, Heading, DOP, SVs used
RXM	Receiver Manager	0x02	Receiver Manager Messages	Pseudo Ranges, avg. C/N0, Channel STATUS
INF	Informative	0x04	Printf-Style Messages	Error, Warning, Notice
ACK	Acknowledgement	0x05	Reply to CFG Input Messages	Ack / Nack
CFG	Configuration	0x06	Receiver Configuration Input	Set Dynamic Model, Set DOP Mask
UPD	Update	0x09	Firmware Update Messages	
MON	Monitor	0x0A	ANTARIS® Monitor	Stack Usage, CPU Load, Communication, IPC and task status
AID	Aiding	0x0B	Navigation Aiding	Position, Time, Ephemeris, Almanac feeds
USR	User	0x4x	SCK Customer Messages	SCK Customer Messages
TIM	Timing	0x0D	Timing	Timepulse data, Time mark data

**Table 24: UBX Message Class**

**! Warning** All remaining class IDs are reserved

### 4.4.3.3 UBX Payload

#### Structure Packing

Values are placed in an order that structure packing is not a problem. This means that 2-Byte values shall start on offsets, which are a multiple of 2, 4-byte values shall start at a multiple of 4, and so on. This can easily be achieved by placing the largest values first in the Message payload (e.g. R8), and ending with the smallest (i.e. one-byters such as U1) values.

#### Message Naming

Adding the class name and a dash in front of the message name does refer to messages. For example, the ECEF-Message is referred to as NAV-POSECEF. Adding a dash and the name, e.g. NAV-POSECEF-X, does referring to values.

#### Number Formats

All multi-byte values are ordered in Little Endian manner, unless mentioned otherwise. All floating-point values are transmitted in IEEE754 single or double precision. A technical description of the IEEE754 format can be found in the Answer Book from the ADS1.x (ARM Developers Suite) toolkit.

The following table gives information about the various values:

Number Formats					
Short	Type	Size (Bytes)	Comment	Min/Max	Resolution
U1	Unsigned Char	1		0...255	1
I1	Signed Char	1	2's complement	-128...127	1
U2	Unsigned Short	2		0...65535	1
I2	Signed Short	2	2's complement	-32768...32767	1
U4	Unsigned Long	4		0...4'294'967'295	1
I4	Signed Long	4	2's complement	-2'147'483'648... 2'147'483'647	1
R4	IEEE 754 Single Precision	4		$-1 * 2^{+127} \dots 2^{+127}$	$\sim \text{Value} * 2^{-24}$
R8	IEEE 754 Double Precision	8		$-1 * 2^{+1023} \dots 2^{+1023}$	$\sim \text{Value} * 2^{-53}$
CH	ASCII / ISO 8859.1 Encoding	1			

**Table 25: Internal Field Number Formats**

### UBX Checksum

The checksum is calculated over the packet, starting and including the CLASS field, up until, but excluding, the Checksum Field:

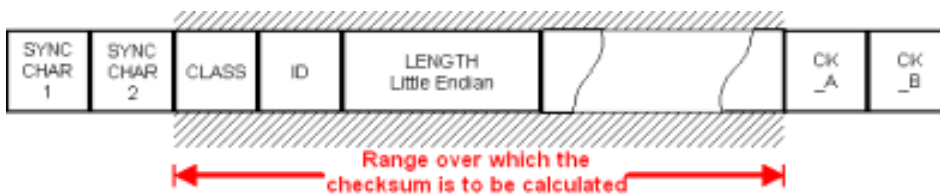

**Figure 71: UBX Checksum range**

The checksum algorithm used is the 8-Bit Fletcher Algorithm, which is being used in the TCP standard (RFC 1145). This algorithm works as follows:

Buffer[N] contains the data over which the checksum is to be calculated.

The two CK\_ values are 8-Bit Unsigned Integers, only! If you implement it with larger-sized integer values, make sure to mask both **CK\_A** and **CK\_B** with **0xFF** after both operations in the loop.

```

CK_A = 0, CK_B = 0;
For(i=0; i<N; i++)
{
    CK_A = CK_A + Buffer[i];
    CK_B = CK_B + CK_A;
}

```

After the loop, we end up having two `UINT8` values, which are transmitted at the end of the packet.

#### 4.4.3.4 UBX Message Flow

There are certain features associated with the messages being sent back and forth:

- Acknowledgement  
When messages from the Class CFG are sent to the receiver, the receiver will send an Acknowledge or a Not Acknowledge message back to the sender, depending on whether or not the message was processed correctly.
- Polling Mechanism  
Most messages that can be output by the receiver can also be polled.

There is not a single specific message, which polls any other message. The UBX protocol was designed, that when sending a message with no payload (or just a single parameter which identifies the poll request) the message is polled.

To configure UBX output messages to a specific repetition rate use UBX-CFG-MSG.

#### 4.4.4 NMEA Protocol

The NMEA protocol is an industry-standard protocol that was developed for marine electronics and was originally designed to allow data exchange between various sensors and navigation equipment aboard ships. Nowadays, it is a de-facto standard for GPS receiver data output. For further information on the NMEA Standard please refer to "NMEA 0183 Standard For Interfacing Marine Electronic Devices", Version 2.300, March 1, 1998. The full specification of the protocol is available from the National Marine Electronics Association at <http://www.nmea.org>.

-  **Note** UBX protocol offers a greater flexibility and more powerful messages than NMEA protocol. It's optimized to communicate with u-center AE software to get the best performance and optimal debugging.

##### 4.4.4.1 NMEA Protocol Overview

The NMEA protocol is an ASCII-based protocol. Records start with a \$ and end with carriage return/line feed. GPS specific messages all start with \$GPxxx where xxx is a three-letter identifier of the message data that follows. NMEA messages have a checksum, which allows detection of corrupted data transfers. *Figure 72* shows the structure of a NMEA protocol message.

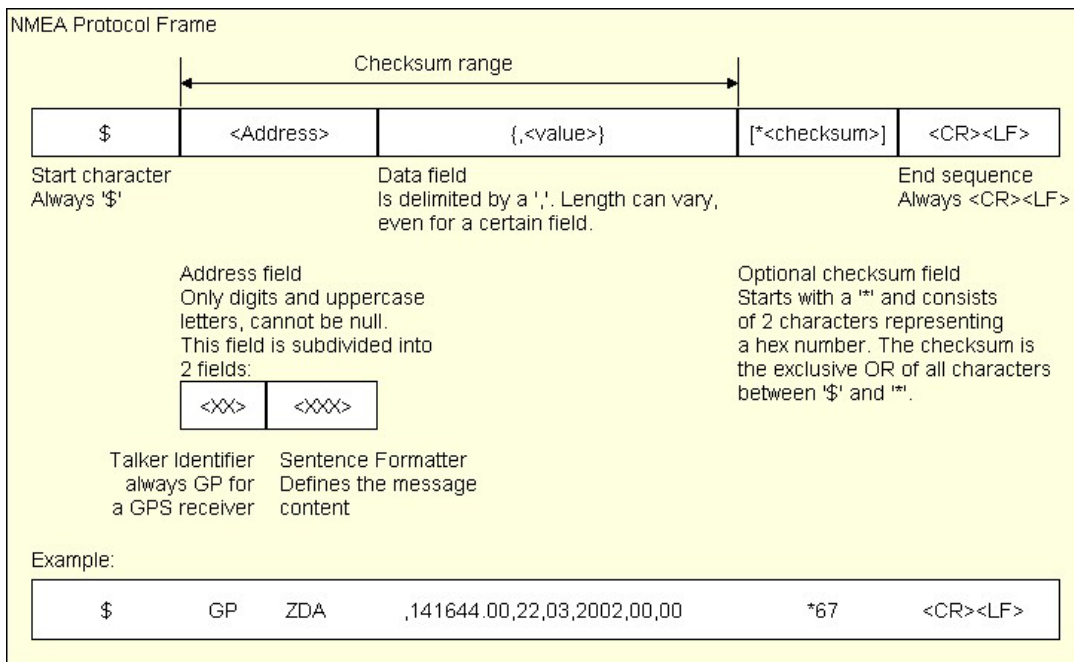

**Figure 72: NMEA Protocol Framing**

### NMEA Parser

The NMEA specification is fairly open and allows minor variations in the implementation (e.g. number of position after decimal point, etc.) but it always requests commas between as a separator between NMEA data fields. One should therefore write a parser that searches for commas and extracts everything between two commas. This way, the parser is independent of the number of digits for the individual message fields. It will even be able to handle empty fields ",,". Beside the commas, a good parser should be able to handle the valid flags correctly. Data are only valid if the valid flag is set to valid. If it's set to invalid, the NMEA parser should reject data output by the receiver. By no means should it forward it to the application.

### NMEA messages supported by the ANTARIS®4 GPS Technology

The ANTARIS®4 GPS Technology supports NMEA-0183, version 2.3. This is upward compatible with NMEA-0183 version 3.0. The NMEA protocol does not take advantage of all the features of the ANTARIS®4 GPS Technology, due to bandwidth limitations of the ASCII-protocol.

- Standard NMEA
  - DTM - Datum Reference
  - GBS - GNSS Satellite Fault Detection
  - GGA - Global positioning system fix data
  - GLL - Geographic position - latitude/longitude
  - GSA - GNSS DOP and active satellites
  - GSV - GNSS satellites in view
  - RMC - Recommended minimum specific GNSS data
  - VTG - Course over ground and ground speed
  - GRS - GNSS range residuals
  - GST - GNSS pseudo range error statistics
  - TXT – Text messages
  - ZDA - Time and date

The NMEA standard allows for proprietary, manufacturer-specific messages to be added. These shall be marked with a manufacturer mnemonic. The mnemonic assigned to u-blox is UBX and is used for all non-standard messages.

- Proprietary NMEA:
  - PUBX,00 - Navstar Position (Lat/Long)
  - PUBX,01 - Navstar Position (UTM)
  - PUBX,03 - Navstar Satellite Information
  - PUBX,04 - Navstar Time & Clock Information
  - PUBX,40 - Set NMEA message output rate
  - PUBX,41 - Set Protocols and Baudrate
- Queries
  - GPQ - Polls a standard message
  - PUBX - Polls a PUBX message

For further details, see *ANTARIS® 4 Protocol Specifications [9]*.

#### 4.4.4.2 NMEA Protocol Configuration (UBX – CFG – NMEA)

The NMEA protocol on ANTARIS®4 receivers can be configured to the need of customer applications. As default all invalid position and all positions out of the defined accuracy range are not reported (details see *Section 4.6.9.1*).

Parameter	Description
<b>NMEA Filtering</b>	
Position filtering	If disabled, invalid or old position output is being communicated, but the valid flag indicates that the data is not current.
Masked position filtering	If disabled, Masked position data is still being output, but the valid flag will indicate that the defined accuracy range has been exceeded.
Time filtering	If disabled, the receiver's best knowledge of time is output, even though it might be wrong.
Date filtering	If disabled, the receiver's best knowledge of date is output, even though it might be wrong.
SBAS filtering	If enabled, SBAS satellites are reported according to the NMEA standard.
Track Filtering	If disabled, an unfiltered COG output is being output.
<b>NMEA Version</b>	There are two NMEA standards supported. The default NMEA protocol version is 2.3. Alternatively also Specification version 2.1 can be enabled (for details refer to <i>Section 4.6.9.1</i> ).
<b>NUM SV</b>	This is the Maximum Number of SVs reported in NMEA protocol. This does not affect the receiver's operation. It only limits the number of SVs reported in NMEA mode (this might be needed with older mapping applications which only support 8- or 12-channel receivers).
<b>NMEA Flag</b>	
Compatibility Mode	Some NMEA applications only work with a fixed number of digits behind the decimal comma. Therefore ANTARIS®4 offer a compatibility mode to communicate with the most popular map applications (e.g. NOKIA phone, TOM-TOM receivers).
Consideration Mode	ANTARIS®4 uses a sophisticated signal quality detection scheme, in order to produce the best possible position output. This algorithm considers all SV measurements, and eventually decides to only use a subset thereof, if it improves the overall position accuracy.  If Consideration mode is enabled, all Satellites, which were considered for navigation, are being communicated as being used for the position determination. If Consideration mode is disabled, only those satellites are marked as being used, which after the consideration step remained in the position output.

#### 4.4.5 RTCM Protocol

The RTCM (Radio Technical Commission for Maritime Services) protocol is a unidirectional protocol (input to the receiver) supplying the GPS receiver with real-time differential correction data (DGPS). The RTCM protocol specification is available from <http://www.rtc.org/>.

The ANTARIS®4 GPS Technology support RTCM Correction Type Messages 1,2, 3 and 9.



### 4.4.6 How to change between protocols

1. Reconfiguring a port from one protocol to another is a two-step process. First of all, one needs to assign the preferred protocol(s) to a port. One port can handle several protocols at the same time (e.g. NMEA and UBX). By default, all ports are configured for UBX and NMEA protocol so in most cases, it's not necessary to change the port settings at all (UBX-CFG-PRT or "PUBX,41" messages).
2. Activate certain messages on each port.

## 4.5 Acquisition

At system power up the ANTARIS®4 GPS Software executes the initial acquisition code. This part of the GPS Software defines three different strategies:

- Coldstart
- Warmstart
- Hotstart

Depending on the amount of valid orbital information available, the receiver chooses the fastest possible startup scenario. Before the receiver can calculate a position fix it must acquire and track GPS signals.

**Acquisition** is the process of 'locking' onto the signal. The SV search and acquisition time highly depends on the signal level. For best performance high signal levels are preferred.

After acquisition, the receiver will have to **synchronize** to the data stream, and download orbit data from the 50Bits/s data stream. This can only be done down to a certain signal level (~25-30dBHz). If the signal level falls below that threshold, downloading data is halted, and can only be resumed once the signal level is above the threshold, again. A first position fix can only be achieved if orbit data for a sufficient number of satellites has been decoded.

**Tracking** is the process of maintaining lock on a previously acquired signal. If orbit data has been downloaded before, and the receiver is calculating position fixes, it can continue to do so even when the signal level falls below the minimum signal level that would be required for data decoding.

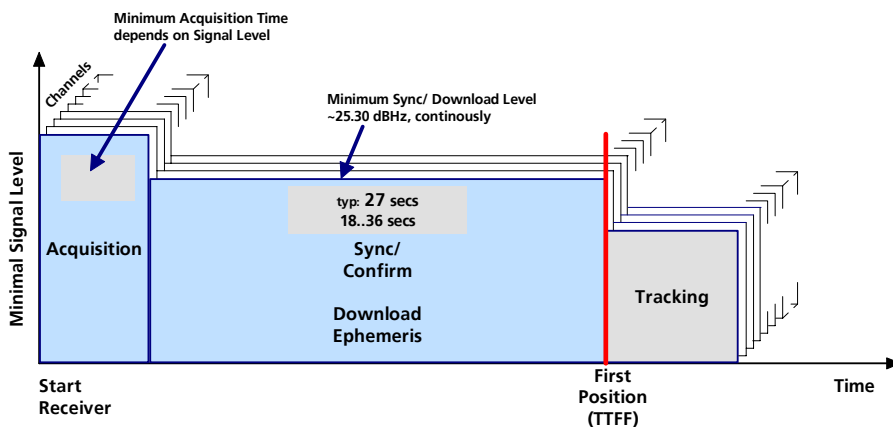

Figure 73: GPS Signal Acquisition

### 4.5.1 Coldstart Strategy

In Coldstart, the receiver searches all valid SV numbers, from 1 to 32, in a predefined order. As soon as SVs are found, they are transferred to tracking and ephemeris decoding starts. This process takes between 18 to 36 seconds with good sky view, but can take much longer otherwise.

Once there are sufficient SVs with valid ephemeris, position fixes are calculated and output.

### 4.5.2 Warmstart Strategy

In Warmstart, the receiver reads the approximate time (from RTC clock), position and almanac information from Battery Backup RAM, assigns up to 12 channels with currently visible SVs and tries to acquire them. The remaining channels will be assigned to non-visible SVs as the receiver may have been moved to another location during off time.

Once sufficient SVs are found and ephemeris is decoded, the receiver starts to navigate.

### 4.5.3 Hotstart Strategy

In Hotstart, the receiver reads the approximate time (from RTC clock), position, almanac and ephemeris information from Battery Backup RAM, assigns up to 12 channels with currently visible SVs and tries to acquire them. The remaining channels will be assigned to non-visible SVs as the receiver may have been moved to another location during off time.

Once sufficient SVs are found the receiver starts to navigate.

### 4.5.4 Aiding / Assisted GPS (AGPS)

The ANTARIS®4 aiding feature allows supplying external information to improve Time To First Fix (TTFF). This is particularly useful if a receiver is operated in an environment with poor/limited sky view or does not have a backup battery. Depending on the information provided, the receiver will perform the best possible startup scenario.

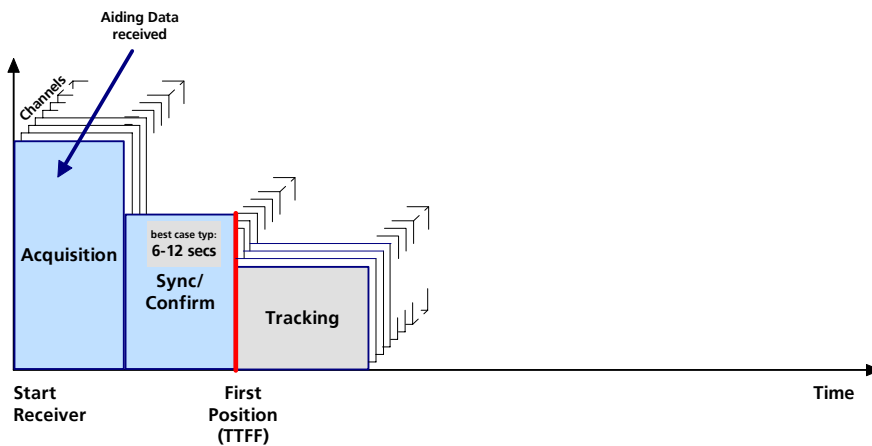

**Figure 74: GPS Signal Acquisition with Aiding**

Providing ephemeris data for the visible satellites can improve the TTFF in urban canyons (downloading the ephemeris requires a direct line-of-sight to each satellite for at least 18s, which is difficult to achieve for the low elevation satellites in urban or mountainous areas). If not only the ephemeris but also current time and approximate receiver position (and possibly the almanac too) are downloaded to the receiver, the TTFF can be further reduced as the receiver can skip certain steps during the acquisition procedure.

The minimal TTFF of about 4s is achieved by providing precise hardware time synchronization.

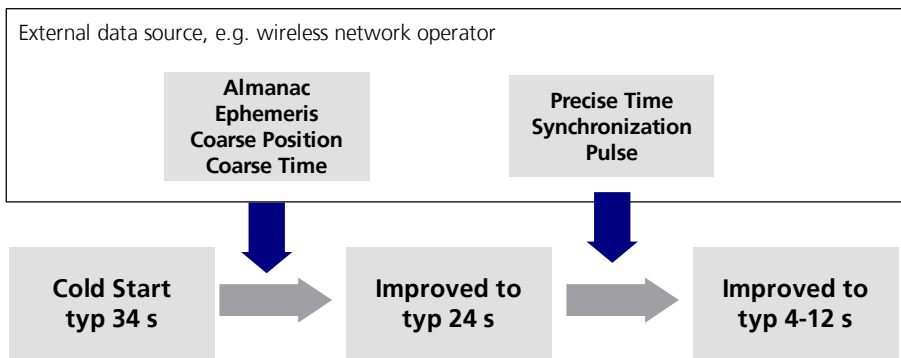

Figure 75: Aiding Principal

### Aiding Sequence

1. Send UBX-AID-EPH (ephemeris) message
2. Send UBX-AID-INI (time, clock and position) message. Do not forget to set the ‘Accurate time is input with time pulse’ if the option hardware time synchronization pulse is desired.
3. Apply optional hardware time synchronization pulse within 0.5s **after** sending the AID-INI message if hardware time synchronization is required. Before applying the time pulse, allow the GPS receiver to parse and process the AID-HUI message. The time for parsing depends on the baudrate. The processing time is 100ms maximum.
4. Send optional UBX-AID-HUI (health, UTC and ionosphere parameters) message
5. Send optional UBX-AID-ALM (almanac) message

### UBX Aiding messages

Message	Description
AID-REQ	Virtual Aiding configuration message to enable aiding request at startup. If this message is enabled, the Aiding Client will automatically poll aiding data from an Aiding Server with an AID-DATA message in case of a cold start.
AID-DATA	Polls all GPS Initial Aiding Data
AID-INI	Contains position, time, clock drift and validation parameters of the aiding data.
AID-HUI	Contains health bit mask, UTC time and Klobuchar parameters. This message is not required to achieve a good TTFF, but it helps to achieve good position accuracy and to correct the UTC offset.
AID-ALM	Contains the almanac data of one SV.
AID-EPH	Contains the ephemeris data of one SV.

Table 26: Aiding messages

For further information about the UBX aiding messages, refer to the *ANTARIS®4 Protocol Specifications [9]*.

### 4.5.5 AssistNow® Online

AssistNow® Online is u-blox' end-to-end Assisted GPS (A-GPS) solution that boosts GPS acquisition performance, bringing Time To First Fix (TTFF) down to seconds. The system works by accessing assistance data such as Ephemeris, Almanac and accurate time from our Global Reference Network of globally placed GPS receivers. With A-GPS, the receiver can acquire satellites and provide accurate position data instantly on demand, even under poor signal conditions.

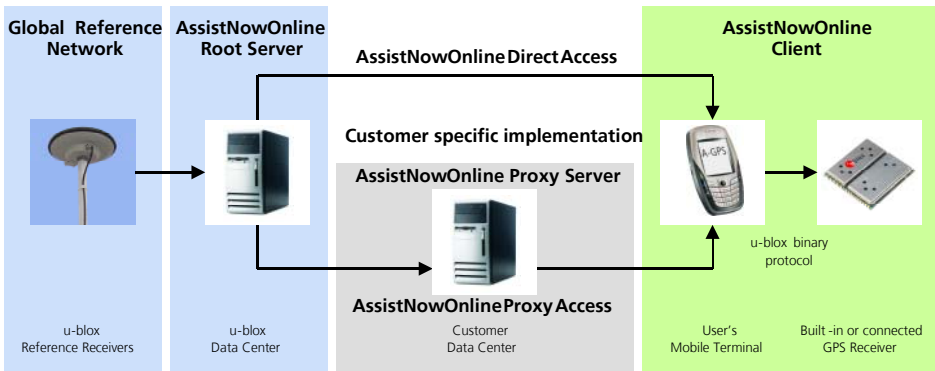

**Figure 78: AssistNow® Online Framework**

AssistNow® Online makes use of User Plane communication and open standards such as TCP/IP. Therefore, it works on all standard mobile communication networks that support Internet access, including GPRS, UMTS and Wireless LAN. No special arrangements need to be made with mobile network operators to enable AssistNow Online.

**Note:** All ANTARIS®4 GPS receivers support AssistNow® Online.

### 4.5.6 AssistNow® Offline

AssistNow® Offline is an A-GPS service that boosts GPS acquisition performance, bringing Time To First Fix (TTFF) down to seconds. Unlike AssistNow Online, this solution enables instant positioning without the need for connectivity at start-up.

The system works by using AlmanacPlus® differential almanac correction data to speed up acquisition, enabling a position fix within seconds. Users access the data by means of occasional Internet downloads, at the user's convenience.

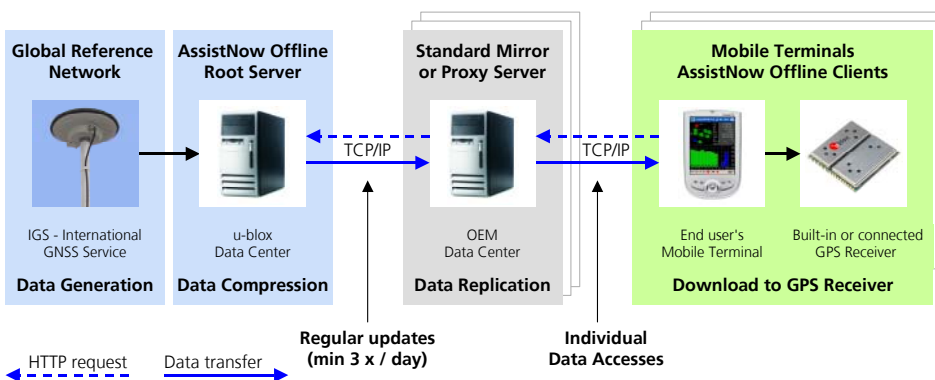

**Figure 79: AssistNow® Offline Framework**

u-blox provides AlmanacPlus® data files in different sizes, which contain differential almanac corrections that are valid for a period of between 1 and 14 days thereafter. Users can download correction data anytime they have an Internet connection, for example at home or in the office. The GPS receiver stores the downloaded data in the non-volatile Flash EPROM.

AssistNow® Offline works in locations without any wireless connectivity as the correction data files reside in the receiver. This makes them immediately available upon start-up, eliminating connection set-up delays, download waiting times and call charges.

**Note:** All ANTARIS®4 GPS receivers with Flash EPROM are AssistNow® Offline capable but require a special firmware.

### 4.5.7 SuperSense® GPS - Weak Signal GPS (TIM-4H/ LEA-4H/ TIM-4S/ LEA-4S)

*This section only applies to TIM-4H/TIM-4S, LEA-4H/LEA-4S and NEO-4S.*

The SuperSense® technology drastically increases the sensitivity of ANTARIS®4 GPS receivers, thereby enhancing the GPS coverage in areas with obstructed sky view (e.g. urban canyons) and providing positioning in many though not all indoor locations. SuperSense® can integrate the incoming signals much longer than Standard GPS receivers and can track down to levels close to -160dBm, which is about 10dB better than what a ANTARIS®4 Standard GPS receiver can do.

#### Automatic Selection of optimal Sensitivity

The SuperSense® firmware automatically adjusts the sensitivity settings for best performance by applying individual integration times for each channel depending on the signal strength. For an optimized startup performance (i.e. automotive applications) another sensitivity mode may be considered (see Section 4.5.8).

#### Accuracy and Dynamic Responsiveness

In the presence of strong signals, the performance and dynamic responsiveness of SuperSense® is comparable to Standard GPS receivers like TIM-4A or TIM-4P. The navigation accuracy under dynamic conditions will be lower for weaker signals due to the long integration time but also due to the fact that SuperSense will have to rely on reflected signals in order to achieve position fixes (see Figure 80).

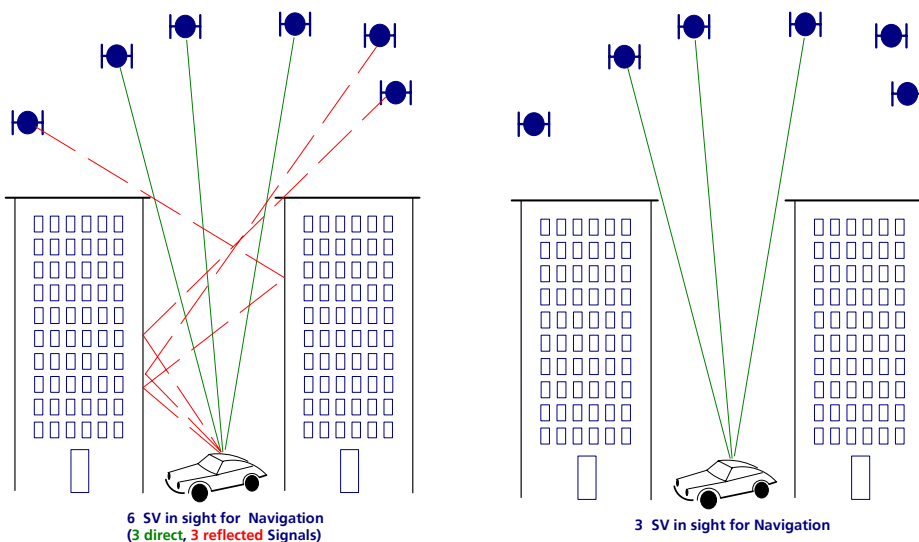

**Figure 80: Direct line-of-sight versus reflected signals**

### **Acquisition and Ephemeris Download**

Longer integration times also improve the acquisition sensitivity but it's not possible to reach the tracking sensitivity. One of the main issues is that the decoding of the 50 bit-per-second data from the satellites (containing the ephemeris data) is not possible at very low signal strength. This limits the cold and warmstart sensitivity but it also affects receivers with a prolonged exposure to very weak GPS signals since ephemeris data are only valid for about 2 hours. Therefore, the GPS receiver must periodically be moved to typical 'outdoor' environment with strong signals in order to receive updated ephemeris and other data. Alternatively, one could provide ephemeris to the receiver with the AID-EPH message (ephemeris aiding).

### **Power Consumption**

The power consumption of SuperSense® is only marginally higher compared to Standard ANTARIS® GPS receivers.

### 4.5.8 Sensitivity Settings (Tracking and Acquisition Modes)

For a given hardware setup (antenna and receiver), higher sensitivity can be reached by extending the integration time of the GPS signal. This means that higher sensitivity is a trade-off versus the time it takes to detect a GPS signal. Therefore, both the hardware setup and the user application determine which sensitivity mode will provide the best performance.

The ANTARIS<sup>®</sup>4 GPS Technology allows the sensitivity of the receiver to be modified in four steps. Namely, they are:

- **Auto Sensitivity** (sensitivity automatically adjusted according to measured signal levels).
- **Normal Sensitivity** (trade off between sensitivity and time to acquire)
- **Fast Acquisition** (optimized for fast acquisition, at the cost of 3dB less sensitivity than with the ‘normal’ setting)
- **High Sensitivity** (optimized for higher sensitivity, i.e. 3dB more sensitive than the ‘normal’ setting, at the cost of longer startup times.).

**Note** For SuperSense<sup>®</sup> Receivers the Sensitivity setting only affects the startup performance, but not the tracking performance.

The Sensitivity Setting can be changed using UBX – CFG (Config) – RXM (Receiver Manager) proprietary messages.

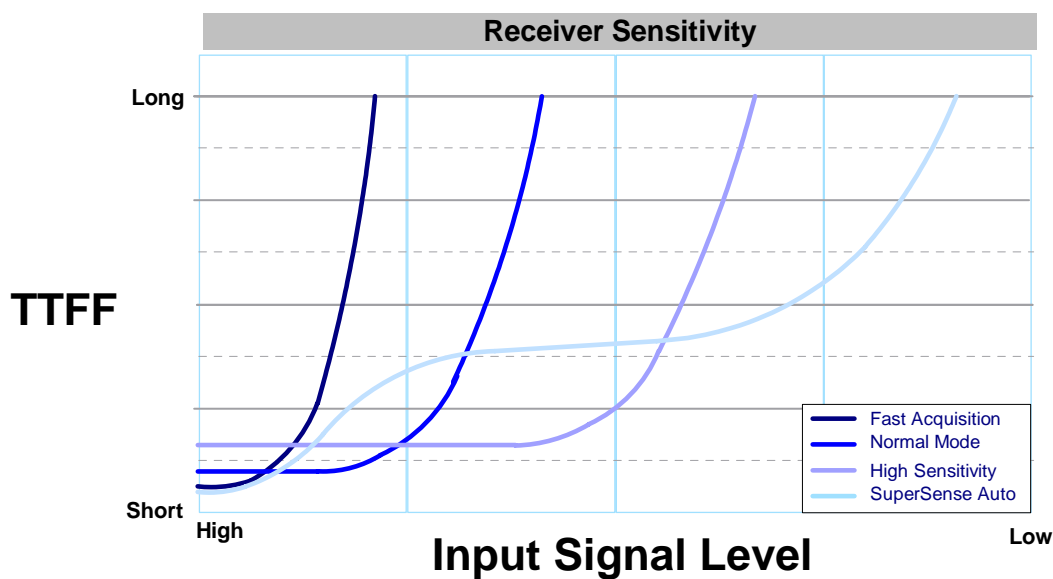

Figure 81: Receiver Sensitivity (Acquisition)

## 4.6 Navigation

Once the GPS receiver is tracking enough satellites, it uses the measurements to calculate the current position. This part of the code is called Navigation Solution.

The following section discusses mainly the usage of the UBX proprietary messages UBX – CFG (Config) – RATE (Rates), UBX – CFG (Config) – DAT (Datums) and UBX – CFG (Config) – NAV2 (Navigation2) to configure the Navigation Engine of the ANTARIS®4 GPS receiver. To get an optimal setting the application environment must be considered.

**Note** UBX – CFG – NAV is not supported anymore for Firmware >3.04.

### 4.6.1 Overview

Parameter	Description
<b>Navigation Output</b>	The ANTARIS®4 GPS Technology outputs the navigation data in LLA (Latitude, Longitude and Altitude), ECEF coordinate frame or Universal Transverse Mercator (UTM) format. The LLA output can be configured to one out of more than 200 pre-defined datums, or to a user datum.
<b>Map Datum</b>	The ANTARIS®4 GPS Technology supports more than 200 different map datums (including one user specific datum) and Universal Transverse Locator (UTM)
<b>Navigation Update Rate</b>	The ANTARIS®4 GPS Technology supports navigation update rates higher than 1 update per second.
<b>Dynamic Platform Model</b>	Dynamic models adjust the navigation engine, tuning the GPS performance to the application environment.
<b>Allow Almanac Navigation</b>	Enable Almanac Navigation (without ephemeris data) as a degraded mode to realize fast fixes with reduced position accuracy.
<b>Navigation Input Filters</b>	Applies a mask to the input parameters of the navigation engine to filter the input data. It screens potentially poor quality data preventing its use in the navigation engine.
<b>Navigation Output Filters</b>	Applies a mask to the position fixes to prevent poor quality from being output. Internally, the positions are still calculated to further track the SVs.
<b>RAIM</b>	Receiver Autonomous Integrity Monitoring
<b>DGPS</b>	Specific Differential GPS parameters

**Table 27: Overview GPS Navigation Parameter**

#### 4.6.1.1 Navigation Output

The ANTARIS®4 GPS Technology outputs the navigation data in LLA (Latitude, Longitude and Altitude), ECEF (Earth Centered Earth Fixed) or UTM (Universal Transverse Mercator) format.

The LLA output can be configured to one out of more than 200 predefined datums or to a user datum. The default datum is WGS84. The altitude is available as height above ellipsoid (HAE). The height above mean sea level (MSL) is available if the default datum WGS84 is selected.

**Note** Refer to *Appendix B* for a list of all predefined datums



## 4.6.2 Navigation Update Rate

The ANTARIS®4 GPS Technology supports raw data and navigation update rates higher or lower than 1 update per second.

Parameter	Description
<b>Measurement Period</b>	Defines the time between two raw data (pseudo range) measurements.
<b>Navigation Rate</b>	Defines the navigation update rate (see formula below).
<b>Time Source<sup>9</sup></b>	Defines whether the navigation update is aligned to GPS time or UTC.

**Table 28: Navigation rate parameters**

$$NavigationUpdateRate[1/s] = \frac{1000}{NavigationRate * MeasurementPeriod[ms]}$$

- ☞ **Note** The update rate has a direct influence on the power consumption. The more fixes that are required, the more CPU power and communication resources are required.
- ☞ **Note** The higher the dynamics of the device holding a GPS system, the faster the position update shall be. For most applications a 1Hz update rate would be sufficient.

## 4.6.3 Dynamic Platform Model

The ANTARIS®4 GPS Technology supports different dynamic platform models to adjust the navigation engine to the expected environment. These platform settings can be changed dynamically without doing a power cycle or reset. It allows a better interpretation of the measurements and hence provides a more accurate position output. Setting the GPS receiver to an unsuitable platform model for the application environment may reduce the receiver performance and position accuracy significantly.

---

<sup>9</sup> This parameter has only an effect if the navigation update rate is less than 1 update per second (e.g. 1 update per 10s).

Platform	Description
<b>Stationary</b>	Timing applications (antenna must be stationary) or other stationary applications <ul style="list-style-type: none"> <li>• Velocity is constrained to 0 m/s</li> <li>• No process noise (assuming zero dynamics)</li> </ul>
<b>Pedestrian</b>	Applications with low accelerations and low speed, as any portable devices carried and moved by manpower. <ul style="list-style-type: none"> <li>• Assuming low accelerations</li> </ul>
<b>Automotive</b>	Used for applications that can be compared with the dynamics of a passenger car. <ul style="list-style-type: none"> <li>• Assuming low process noise</li> <li>• Assuming low vertical acceleration</li> </ul>
<b>At sea</b>	Recommended for applications at sea, with zero vertical velocity. <ul style="list-style-type: none"> <li>• Assuming zero vertical velocity</li> <li>• Assuming low process noise</li> </ul>
<b>Airborne &lt;1g</b>	Used for applications that have to handle a higher dynamic range than a car and higher vertical accelerations. <ul style="list-style-type: none"> <li>• Assuming intermediate process noise</li> <li>• No 2D position fixes supported</li> </ul>
<b>Airborne &lt;2g</b>	Recommended for a typical airplane environment. <ul style="list-style-type: none"> <li>• Assuming high process noise</li> <li>• No 2D position fixes supported</li> </ul>
<b>Airborne &lt;4g</b>	Only recommended for an extreme dynamic environment. <ul style="list-style-type: none"> <li>• Assuming high process noise</li> <li>• No 2D position fixes supported</li> </ul>

**Table 29: Dynamic Platform Model**

**Note** Dynamic platforms designed for high acceleration systems (e.g. AIRBORNE < 2G) may result in a greater standard deviation in the reported position.

#### 4.6.4 Static Hold Mode

The Static Hold mode allows the navigation algorithms to decrease the noise in the position output when the velocity is below a pre-defined ‘Static Hold Threshold’. This reduces the position wander caused by environmental issues such as multipath and improves position accuracy especially in stationary applications. By default, static hold mode is disabled.

##### Function

If the speed goes below the defined ‘Static Hold Threshold’, the position is kept constant. Once the static hold mode has been entered, the position and velocity output will kept constant, until there is evidence of movement. Such evidence can be velocity, acceleration, changes of the valid flag (e.g. position accuracy estimate exceeding the Position Accuracy Mask, see also section 4.6.8.1), position displacement, etc.

In older firmware versions (<V5.0), the static hold mode was release if the speed had risen to twice the value of the ‘Static Hold Threshold’ or if the receiver has moved significantly.

## 4.6.5 Degraded Navigation

Degraded navigation describes all navigation modes, which use less than 4 satellites.

### 4.6.5.1 2D Navigation

If the GPS receiver only has 3 satellites to calculate a position, the navigation algorithm uses a constant altitude to make up for the missing fourth satellite. When losing a satellite after a successful 3D fix (min. 4 SV available), the altitude is kept constant to the last known altitude. This is called a 2D fix.

- ☞ **Note** The ANTARIS<sup>®</sup>4 GPS Technology does not calculate any solution with a number of SVs less than 3 SV. Only ANTARIS<sup>®</sup>4 Timing Receivers can calculate timing solution with only one SV.
- ☞ **Note** If the receiver makes initial 2D LSQ fixes during acquisition, the initial altitude is set to 500m. To change the initial altitude use UBX – CFG (Config) - NAV2 (Navigation 2) message.

### 4.6.5.2 Dead Reckoning/ extrapolating positioning

The implemented extrapolation algorithm kicks in as soon as the receiver does no longer achieve a position fix with a sufficient position accuracy or DOP value (can be configured in UBX-CFG-NAV2). It keeps a fix track (heading is equal to the last calculated heading) until the Dead Reckoning Timeout is reached. The position is extrapolated but it's indicated as "NoFix" (except for NMEA V2.1).

- ☞ **Note** For sensor based Dead Reckoning GPS solutions, u-blox offers Dead Reckoning enabled GPS modules (LEA-4R/TIM-4R). They allow high accuracy position solutions for automotive applications at places with poor or no GPS coverage. This technology relies on additional inputs from a turn rate sensor (gyro) and a speed sensor (odometer or wheel tick).

## 4.6.6 Almanac Navigation

The satellite orbit information retrieved from an almanac is much less accurate than the information retrieved from the ephemeris. If during a startup period, only almanac information is available, (e.g. while the ephemeris still is being downloaded) the receiver still is able to navigate based on almanac orbits.

With almanac navigation enabled, when a new satellite rises and its reception just has started, the receiver might use an almanac to use this satellite in the navigation solution until the ephemeris is fully retrieved. By disabling almanac navigation, the receiver does not use the almanac for navigation, but will always wait to collect the entire ephemeris information before including a satellite in the navigation solution.

With an almanac only solution the position will only have an accuracy of a few kilometers. Normal GPS performance requires at least 4 satellites included in the navigation solution, which have ephemeris information available.

Almanac navigation allows much faster start up, as there is no need to wait for the completion of the ephemeris download (>18s). This is useful whenever an inaccurate position is better than no position (e.g. emergency or security devices).

- ☞ **Note** The almanac information is NOT used for calculating a position, if valid ephemeris information is present, regardless of the setting of this flag. But the almanac information is needed to acquire the SV when there is no ephemeris data available.

### 4.6.7 Navigation Input Filters

The navigation input filters mask the input data of the navigation engine. These settings are optimized already. It is not recommended that changes to any parameters be made unless advised by u-blox support engineers.

Parameter	Description
<b>Fix Mode</b>	By default, the receiver calculates a 3D position fix if possible but reverts to a 2D position if necessary ( <b>Automatic 2D/3D</b> ). It's possible to force the receiver to permanently calculate 2D ( <b>2D-only</b> ) or 3D ( <b>3D-only</b> ) positions.
<b>Fix Altitude</b>	Initial altitude used for 2D navigation output. The fix altitude is used if Fix Mode is set to <b>2D-only</b> or in case of a 2D fix after a Coldstart.
<b>Min SVs</b>	Restricts the navigation solution to be calculated with at least n satellites. This could be used to inhibit a solution with only 3 satellites. Set this value to 1 single satellite for timing applications (LEA-4T only).
<b>Max SVs</b>	Uses at most 'n' satellites for a navigation solution.
<b>Initial Min SV</b>	Minimum number of satellites, which must be available before the first position fix will be calculated.
<b>Min C/No</b>	A satellite with a C/NO below this limit is not used for navigation.
<b>Initial Min C/No</b>	Minimum C/NO for the initial fix. Only satellites exceed this threshold will be used for the calculation of the first position fix. This parameter may be set to a higher value than "Min C/No (Nav)" in order to achieve a higher confidence in the accuracy of the first position fix.
<b>Min SV Elevation</b>	Minimum elevation of a satellite above the horizon in order to be used in the navigation solution. Low elevation satellites may provide degraded accuracy, because of the long signal path through the atmosphere.
<b>DR (Dead Reckoning) Timeout<sup>10</sup></b>	The time during which the receiver provides an extrapolated solution. After the DR timeout has expired no GPS solution is provided at all.

Table 30: Navigation Input Filter parameters (UBX-CFG-NAV2)

### 4.6.8 Navigation Output Filters

Parameter	Description
<b>PDOP Mask P Accuracy Mask</b>	The PDOP and Position Accuracy Mask are used to determine, if a position solution is marked valid in the NMEA sentences or the UBX PosLimit Flag is set. A solution is considered valid, when both PDOP and Accuracy lie below the respective limits.
<b>TDOP Mask T Accuracy Mask</b>	The TDOP and Time Accuracy Mask are used to determine, when a Time Pulse should be allowed. The TIMEPULSE is disabled if either TDOP or the time accuracy exceeds its respective limit.

Table 31: Navigation Output Filter parameter

<sup>10</sup> Does not apply to DR enabled receivers (like TIM-LR)

#### **4.6.8.1 PDOP and P Accuracy Mask**

These navigation output filters adjust the valid flag of the NMEA and UBX- message. Users of the UBX protocol have additional access to messages containing an accuracy indicator, along with the position.

#### **4.6.8.2 TDOP and T Accuracy Mask**

The **TDOP** and **T accuracy mask** control the **TIMEPULSE** output. They define when the **TIMEPULSE** is available and within the requested accuracy range. Only when these conditions are met the **TIMEPULSE** is available on the **TIMEPULSE** pin.

## 4.6.9 Position Quality Indicators

### 4.6.9.1 NMEA Valid Flag (Position Fix Indicator)

A position fix is declared as valid if all of the conditions below are met:

- Position fix with at least 3 satellites (2D or 3D fix). In order to ensure a good accuracy, the ANTARIS<sup>®</sup>4 GPS Technology does not support 1D fixes.
- The '3D Position Accuracy Estimate' needs to be below the 'Position Accuracy Mask'
- The PDOP value needs to be below the 'PDOP Accuracy Mask'.

**Note** The 'Position Accuracy Mask' and the 'PDOP Mask' are configurable. This allows customizing the behavior of the valid flag to application requirements (see *Section 4.6.8*)

Table 32 lists of the status fields (valid flags) for the different NMEA message for NMEA standard 0183 Version 2.3:

NMEA Message	Field	No Position Fix (after power-up, after losing Satellite lock)	Valid Position Fix but User Limits exceeded	Dead Reckoning (linear extrapolation)	EKF <sup>11</sup>	2D Position Fix	3D Position Fix	Combined GPS/EKF Position Fix	
GGA	Status	0	0	6	6	1/2	1/2	1/2	
		0=Fix not available/invalid, 1=GPS SPS Mode, Fix valid <sup>12</sup> , 2=Differential GPS, SPS Mode, Fix Valid, 6=Estimated/Dead Reckoning							
GLL	Status	V	V	V	A <sup>13</sup>	A	A	A	
		A=Data VALID, V=Data Invalid (Navigation Receiver Warning)							
	Mode Indicator	N	N	E	E	A/D	A/D	A/D	
		N=No Fix, A=Autonomous GNSS Fix, D=Differential GNSS Fix, E=Estimated/Dead Reckoning Fix							
GSA	Nav Mode	1	1	2	2	2	3	3	
		1=Fix Not available, 2=2D Fix, 3=3D Fix							
RMC	Status	V	V	V	A	A	A	A	
		A=Data VALID, V=Data Invalid (Navigation Receiver Warning)							
	Mode Indicator	N	N	E	E	A/D	A/D	A/D	
		N=No Fix, A=Autonomous GNSS Fix, D=Differential GNSS Fix, E=Estimated/Dead Reckoning Fix							
VTG	Mode Indicator	N	N	E	E	A/D	A/D	A/D	
		N=No Fix, A=Autonomous GNSS Fix, D=Differential GNSS Fix, E=Estimated/Dead Reckoning Fix							

**Table 32: NMEA Valid Flag (0183 Version 2.3)**

<sup>11</sup> TIM-LR / DR enabled receivers only

<sup>12</sup> For DR enabled receiver a valid fix is always a combination of a GPS fix with a DR position based on the attached DR sensor (turn rate sensor, odometer)-

<sup>13</sup> For DR enabled receivers the EKF only fix is considered as valid as long as it's within the defined accuracy range.

Table 33 lists of the status fields (valid flags) for the different NMEA message for NMEA standard 0183 Version 2.2 and smaller:

NMEA Message	Field	No Position Fix (after power-up, after losing Satellite lock)	Valid Position Fix but User Limits exceeded	Dead Reckoning (linear extrapolation)	EKF <sup>14</sup>	2D Position Fix	3D Position Fix	Combined GPS/EKF Position Fix	
GGA	Status	0	0	1	1	1/2	1/2	1/2	
		0=Fix not available/invalid, 1=GPS SPS Mode, Fix valid <sup>15</sup> , Estimated/Dead Reckoning, 2=Differential GPS, SPS Mode, Fix Valid							
GLL	Status	V	V	A	A <sup>16</sup>	A	A	A	
		A=Data VALID, V=Data Invalid (Navigation Receiver Warning)							
GSA	Nav Mode	Not available in this NMEA version							
		1	1	2	2	2	3	3	
		1=Fix Not available, 2=2D Fix, 3=3D Fix							
RMC	Status	V	V	A	A	A	A	A	
		A=Data VALID, V=Data Invalid (Navigation Receiver Warning)							
VTG	Mode Indicator	Not available in this NMEA version							

**Table 33: NMEA Valid Flag (0183 Version 2.2 and smaller)**

### NMEA Output in case of invalid position fixes

The ANTARIS®4 GPS Technology will not output data in case of invalid position fixes. By default, it will output comma-separated fields for position, velocity and time as depicted in *Table 34*.

Data Validity	GGA Output
Invalid time and invalid position	\$GPGGA,,,,,0,0,99.99,,,,,0*48
Valid time, invalid position fix	\$GPGGA,125749.00,,,,,0,0,99.99,,,,,0*6A
Valid time and position fix	\$GPGGA,125822.00,4717.11387,N,00833.91113,E,1,4,2.15,498.4,M,48.0,M,,0*57

**Table 34: NMEA Output in case of invalid position fixes (Firmware ≥V3.00)**

It is also possible to configure receivers to output as well invalid solutions (please refer to *Section 4.4.4.2*)

<sup>14</sup> TIM-LR / DR enabled receivers only

<sup>15</sup> For DR enabled receiver a valid fix is always a combination of a GPS fix with a DR position based on the attached DR sensor (turn rate sensor, odometer)-

<sup>16</sup> For DR enabled receivers the EKF only fix is considered as valid as long as it's in the defined accuracy range.

#### 4.6.9.2 UBX Valid Flag (Position Fix Indicator)

UBX protocol provides status information in abundance. Table 35 lists the position fix flags:

Status Field	Message	Enumeration	Description
GPSfix	NAV-STATUS NAV-SOL	0x00	No Fix
		0x01	Dead Reckoning only
		0x02	2D-fix
		0x03	3D-fix
		0x04	GPS + Dead Reckoning combined <sup>17</sup>
Flags	NAV-STATUS NAV-SOL	0x01	GPS fix OK (i.e. within PDOP & Position Accuracy Masks)
		0x02	DGPS used
		0x04	Week Number valid
		0x08	Time of Week valid

**Table 35: UBX Valid Flags (Position Fix Indicator)**

A position fix shall be treated as valid, if 'GPSfix' reports either a '2D-fix' or a '3D-fix' and 'Flags' indicates 'GPS fix OK'.

For DR enabled receivers a position fix shall be treated as valid if 'GPSfix' reports either a 'GPS + Dead Reckoning combined' or 'Dead Reckoning only' and 'Flags' indicates 'GPS fix OK'.

#### 4.6.9.3 UBX Status Information

In UBX protocol additional status and accuracy information is available in UBX protocol:

Status Field	Message	Enumeration / Unit	Description
Pacc	NAV-SOL NAV-POSECEF	cm	3D Position Accuracy Estimate
SAcc	NAV-SOL NAV-VELECEF NAV-VELNED	cm/s	Speed Accuracy Estimate
CAcc	NAV-VELNED		Course / Heading Accuracy Estimate
Hacc		cm	Horizontal Accuracy Estimate
Vacc		cm	Vertical Accuracy Estimate
TAcc	NAV-TIMEGPS NAV-TIMEUTC	ns	Time Accuracy Estimate
PDOP	NAV-SOL NAV-DOP	-	Position DOP
numSV	NAV-SOL	-	Number of SVs used in Nav Solution
DiffS	NAV-STATUS		Bits [1:0] - DGPS Input Status <ul style="list-style-type: none"> <li>• 00: none</li> <li>• 01: PR+PRR Correction</li> <li>• 10: PR+PRR+CP Correction</li> <li>• 11: High accuracy PR+PRR+CP Correction</li> </ul>
TTF	NAV-STATUS	ms	Time to first fix (millisecond time tag)
MSSS	NAV-STATUS	ms	Milliseconds since Startup / Reset
Valid (Time)	NAV-TIMEGPS NAV-TIMEUTC	0x01	Valid Time of Week
		0x02	Valid Week Number
		0x04	Valid UTC (Leap Seconds known)

**Table 36: Status Information in UBX Protocol**

For further information about the UBX messages, refer to the *ANTARIS®4 Protocol Specifications [9]*.

<sup>17</sup> Requires TIM-LR or SBR-LS



#### 4.6.10 DGPS (Differential GPS)

For information about the RTCM protocol refer to *Section 4.4.5*.

#### 4.6.11 SBAS (Satellite Based Augmentation Systems)

##### 4.6.11.1 SBAS Features

ANTARIS<sup>®</sup>4 is capable of receiving multiple SBAS satellites in parallel, even from different SBAS systems (WAAS, EGNOS, etc.). They can be tracked and used for navigation simultaneously. Up to three SBAS satellites can be searched in parallel and every SBAS satellite tracked utilizes one vacant GPS receiver channel. Only the number of receiver channels limits the total number of satellites used, which is 16 for ANTARIS<sup>®</sup>4 based products. Each SBAS satellite, which broadcasts ephemeris or almanac information, can be used for navigation, just like a normal GPS satellite.

For receiving correction data, the ANTARIS<sup>®</sup>4 GPS receiver automatically chooses the best SBAS satellite as its primary source. It will select only one since the information received from other SBAS GEOs is redundant and/or could be inconsistent. The selection strategy is determined by the proximity of the GEOs, the services offered by the GEO, the configuration of the receiver (Testmode allowed/disallowed, Integrity enabled/disabled) and the signal link quality to the GEO.

In case corrections are available from the chosen GEO and used in the navigation calculation, the DGPS flag is set in the receiver's output protocol messages.

The most important SBAS feature for accuracy improvement is Ionosphere correction. The measured data from RIMS stations of a region are combined to a TEC (Total Electron Content) Map. This map is transferred to the GPS devices via the GEOs to allow a correction of the ionosphere error on each received satellite.

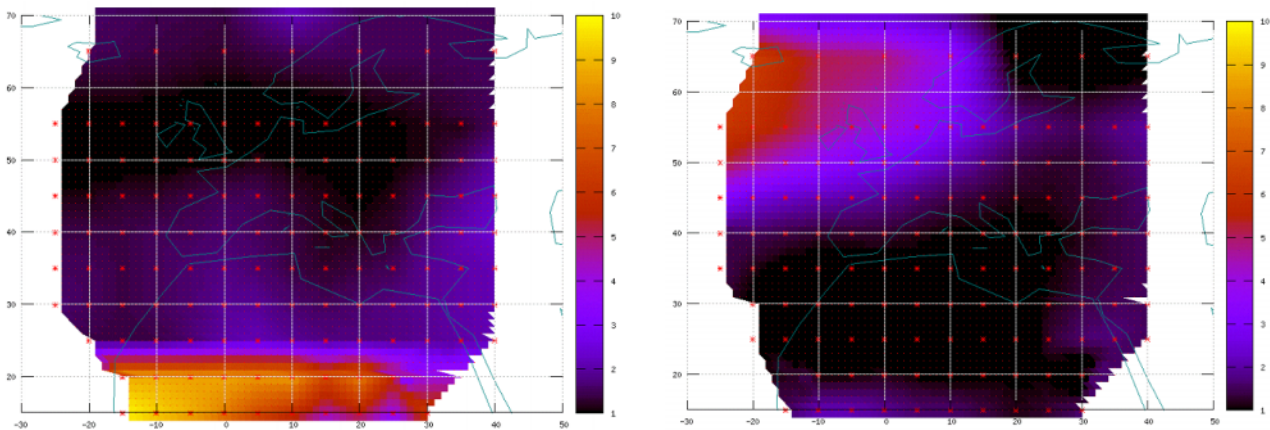

**Figure 84: Examples of a TEC-Map over Europe**

The following SBAS messages are supported, in accordance to standard DO-229C:

Message Type	Message Content	Used from
0(0/2)	Test Mode	All
1	PRN Mask Assignment	Primary
2, 3, 4, 5	Fast Corrections	Primary
6	Integrity	Primary
7	Fast Correction Degradation	Primary
9	GEO Navigation (Ephemeris)	All
10	Degradation	Primary
12	Time Offset	Primary
17	GEO Almanachs	All
18	Ionosphere Grid Point Assignment	Primary
24	Mixed Fast / Long term Corrections	Primary
25	Long term Corrections	Primary
26	Ionosphere Delays	Primary

**Table 37: Supported SBAS messages**

**Note** This ANTARIS®4 SBAS implementation is – in accordance with standard RTCA/DO-229C – a class Beta-1 equipment. All timeouts etc. are chosen for the En Route Case. Do not use this equipment for safety of life applications!

As each GEO services a specific region, the correction signal is only useful within that region. Therefore, mission planning is crucial to determine the best possible configuration. The different stages (Testmode vs. Operational) of the various SBAS systems further complicate this task. The following examples show possible scenarios:

**Example 1: SBAS Receiver in North America**

At the time of writing, the WAAS system is in operational stage, whereas the EGNOS system is still in test mode (ESTB). Therefore, and especially in the eastern parts of the US, care must be taken in order not to have EGNOS satellites taking preference over WAAS satellites. This can be achieved by Disallowing Test Mode use (this inhibits EGNOS satellites from being used as a correction data source), but keeping the PRN Mask to have all SBAS GEOs enabled (which allows EGNOS GEOs to be used for navigation).

**Example 2: SBAS Receiver in Europe**

At the time of writing, the EGNOS system is still in test mode. To try out EGNOS operation, Testmode usage must be enabled. Since the WAAS GEO #122 can be received in the western parts of Europe, but since this GEO does not carry correction data for the European continent, the GEOs from all but the EGNOS system should be disallowed, using the PRN Mask. It is important to understand that while EGNOS is in test mode, anything can happen to the EGNOS signals, such as sudden interruption of service or broadcast of invalid or inconsistent data.

**Note** The ANTARIS® 4 GPS receiver makes always use of the best available SBAS correction data.

#### 4.6.11.2 SBAS Configuration

To configure the SBAS functionalities use the UBX proprietary message UBX – CFG (Config) – SBAS (SBAS Configuration) message.

Parameter		Description
<b>Mode</b>	<b>SBAS Subsystem</b>	Enables or disables the SBAS subsystem
	<b>Allow test mode usage (Msg0)</b>	Allow / Disallow SBAS usage from satellites in Test Mode (Message 0)
<b>Services/ Usage</b>	<b>Ranging</b>	Use the SBAS satellites for navigation
	<b>Apply SBAS correction data</b>	Combined enable/disable switch for Fast-, Long-Term and Ionosphere Corrections
	<b>Apply integrity information</b>	Use integrity data
<b>Number of search channels</b>		Sets on how many channels SBAS satellites are searched in parallel. SBAS satellites, which are already received, do not count for the maximum.
<b>PRN Mask</b>		Allows to selectively enable/disable SBAS satellite. With this parameter, for example, one can restrict SBAS usage to WAAS-only

Table 39: SBAS parameters

By default SBAS is enabled with one SBAS search channel and it will use any received SBAS satellites for navigation.

#### 4.6.11.3 SBAS Status Information

Parameter	Description
<b>GEO/ ID</b>	SBAS GEO which is used for receiving correction data is shown (this GEO is automatically chosen and can change depending on signal conditions and distance from the receiver's location)
<b>System</b>	SBAS System, which is being used for correction data (WAAS, EGNOS, etc.)
<b>Mode</b>	Indicates the mode of the tracked SBAS satellite (Disable, Testmode, Operational)
<b>For each received GNSS signal (GPS and SBAS)</b>	<ul style="list-style-type: none"> <li>The SV Number</li> <li>UDRE; monitoring status as defined in DO-229C</li> <li>Whether or not fast corrections are used for this SV. The PRC value in meters is given</li> <li>Whether or not Ionosphere corrections are used for this SV. The slant PRC delay is given in meters.</li> <li>Whether or not Long term corrections are used for this SV</li> <li>Whether or not Integrity Data is used for this SV</li> <li>The GNSS system for this SV (currently limited to GPS or SBAS)</li> <li>The Services and Status provided by this SV. Can be a combination of 'Ranging', 'Correction Data', 'Integrity Information' and 'Testmode'.</li> </ul>

**Note** The Message UBX-NAV-DGPS does not monitor SBAS correction data. That message is used for monitoring RTCM-input, only!

**Warning** The ANTARIS®4 SBAS implementation is not certified, nor is it planned to get certification for avionics. ANTARIS®4 GPS receivers shall not – under any circumstances – be used for safety-of-life applications or avionics navigation.

#### **4.6.12 RAIM (Receiver Autonomous Integrity Monitoring)**

RAIM is a process where the GPS unit itself uses various techniques to monitor the signals it is receiving from the satellites, ensuring that the information used in the navigation solution is valid. Four SVs are required for a 3D navigation solution. The presence of one bad SV could be detected if five SVs were available. A bad SV could be identified and eliminated from the solution if six or more SVs are available (Fault Detection and Exclusion (FDE)).

The ANTARIS®4 Technology supports RAIM and has the ability to enable/disable this feature using software commands.

RAIM can only work with sufficient SV visibility and acceptable DOP geometry. RAIM is activated by default and it is recommended to enable it all the time.

The status of the RAIM system is reported in the NMEA – GPGBS (GNSS Satellite Fault Detection) message.

## 4.7 Timing

### 4.7.1 TIMEPULSE

ANTARIS<sup>®</sup>4 GPS receivers provide a hardware-synchronized **TIMEPULSE** (Pin 29) with a Time **Pulse Period** of 1 ms to 60 s. The polarity (rising or falling edge) and the pulse duration can be configured. Use the UBX proprietary message UBX - CFG (Config) - TP (Time Pulse) to change the TIMEPULSE settings. The UBX - TIM (Time) - TP (Timepulse) message provides the time information for the next TIMEPULSE, time source and a quantization error.

Parameter	Description
<b>Pulse Mode</b>	'falling edge' <b>TIMEPULSE</b> synchronization on the falling edge 'disabled' <b>TIMEPULSE</b> disabled (output signal low) 'rising edge' <b>TIMEPULSE</b> synchronization on the rising edge
<b>Pulse Period</b>	Period of the <b>TIMEPULSE</b>
<b>Pulse Length</b>	Duration of the <b>TIMEPULSE</b>
<b>Pulse Frequency</b>	The pulse frequency is calculated from the pulse period (u-center output only)
<b>Time Source</b>	Selection whether the Time Pulse is GPS time or UTC time synchronized
<b>Cable Delay</b>	Signal delay in the cable from the antenna to the ANTARIS <sup>®</sup> 4 GPS Receiver
<b>User Delay</b>	The cable delay from ANTARIS <sup>®</sup> 4 GPS Receiver to the user device plus signal delay of any user application
<b>RF Group Delay</b>	Delay of the signal in the ANTARIS <sup>®</sup> 4 GPS Receiver RF module (hard coded)

Table 40: TIMEPULSE Parameter description

#### Pulse Mode: Rising



#### Pulse Mode: Falling

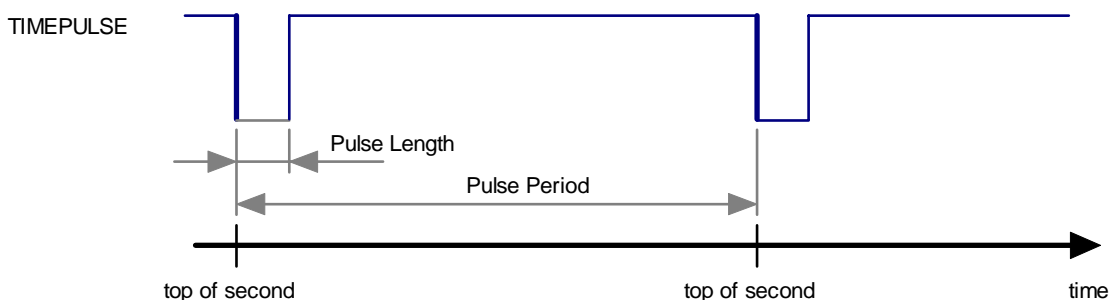

Figure 85: Example of a 1PPS Signal designed with TIMEPULSE

As a pulse reference **GPS** or **UTC time** can be selected. This makes a difference if the Pulse Period exceeds 1s. As the TIMEPULSE is synchronized with GPS- or UTC-time the Pulse Period must fulfill the following condition:

$$n \cdot \text{PulsePeriod} = 60s \quad \text{n must be an integer value!}$$

**Note** The Maximum Pulse Length can't exceed the Pulse Period minus 1ms.

Figure 86 shows the sequential order of the signal present at pin **TIMEPULSE** and the respective output message for the simple case of 1 pulse per second and a one second navigation update rate.

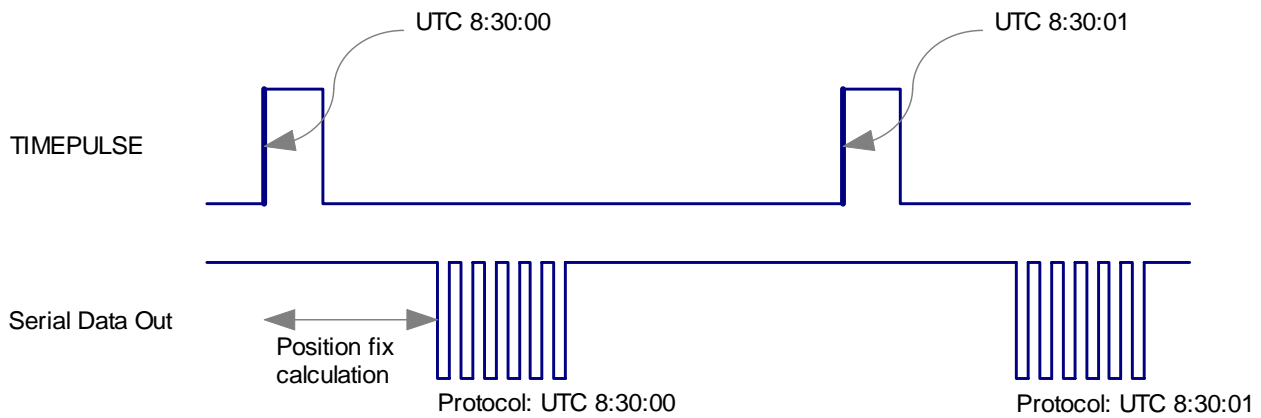

**Figure 86: TIMEPULSE output signal and protocol time message, example for 1 s period and rising edge configuration**

The navigation update rate and TIMEPULSE period should be configured to result in a meaningful pattern. For example, having four navigation updates per second and 3 **TIMEPULSE**'s per second would make correlation of **TIMEPULSE** output and output message difficult.

The **TIMEPULSE** signal is aligned to the sampling clock of 23.104 MHz. This results in a timing resolution of 43 ns. This quantization error has to be added to the time accuracy estimation delivered through the timing message UBX – TIM (Timing)- TP (Timepulse).

The rise time of the **TIMEPULSE** signal affects the absolute accuracy of the TIMEPULSE signal and needs to be considered. At 15 pF load capacitance the output driver is able to deliver a typical rise time of 7 ns, but the maximum rise time may also reach 25 ns. Low load on this pin is therefore mandatory.

The GPS receiver always calculates time and position at the phase center of the GPS antenna. As the application using the time signal is not directly at the antenna, any delays caused by cables, filters and any other processes have to be considered. The Cable Delay (5.5 ns / m for PTFE isolated coaxial cable) is the delay in the antenna cable from the GPS antenna phase center to the Antenna Pin, the RF Group Delay is the delay from the Antenna Pin to the TIMEPULSE Pin (which is defined as a constant) and the User Delay are any other delays in the user application.

- ☞ **Note** When using the **TIMEPULSE** for a Timing Application it is recommended that the RF signal delay be calibrated against a reference-timing source.
- ☞ **Note** To get the best timing accuracy with the GPS antenna, a fixed position is needed and the receiver must be configured to the static platform (refer to *Section 4.6.3*).
- ☞ **Note** Use LEA-4T for Applications with high timing accuracy requirements.

#### 4.7.1.1 TIMEPULSE, Application Examples

The default setting for the TIMEPULSE defines a 1PPS signal, with a defined accuracy if the **TDOP** and **T accuracy masks** are used. Parameter changes can be made according to specific application requirements.

- ☞ **Note** If there is 'No Fix' or **TDOP** or **T accuracy mask** are exceeded no TIMEPULSE is being output.

#### 4.7.1.2 1PPS TIMEPULSE

The following example shows a 1PPS rising edge triggered TIMEPULSE aligned to GPS time

Parameter values			
Pulse Mode	+ 1 – rising		
Pulse Period [ms]	1000	Pulse Length [ms]	100
Time Source	1 – GPS		
Cable Delay [ns]	50	User Delay [ns]	0

Table 41: 1PPS TIMEPULSE Parameter settings

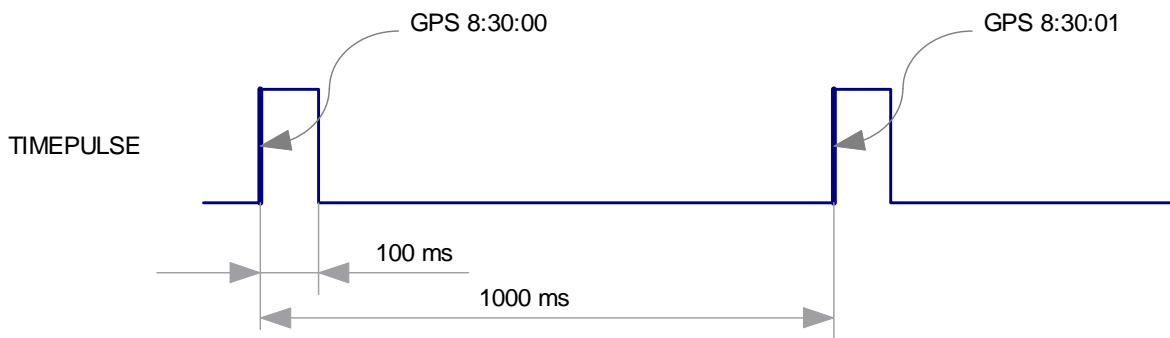

Figure 87: 1PPS TIMEPULSE Output Signal

#### 4.7.1.3 1kHz TIMEPULSE

The following example shows a 1kHz, rising edge triggered TIMEPULSE aligned to GPS time

Parameter values			
Pulse Mode	+ 1 – rising		
Pulse Period [ms]	1	Pulse Length [ms]	0.1
Time Source	1 – GPS		
Cable Delay [ns]	50	User Delay [ns]	0

Table 42: 1kHz TIMEPULSE Parameter settings

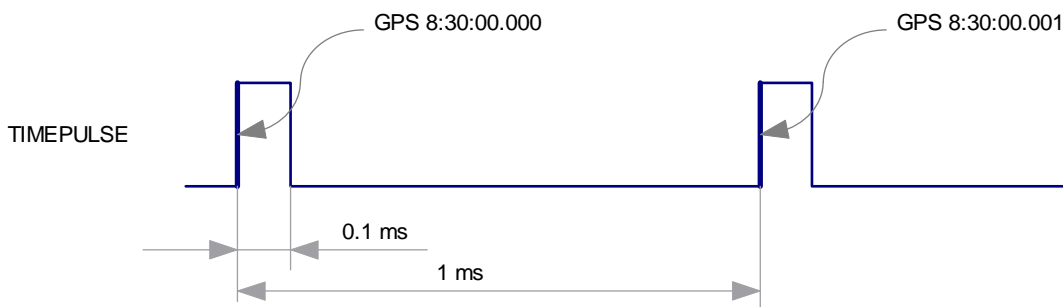

Figure 88: 1kHz TIMEPULSE Output Signal

#### 4.7.1.4 60s UTC aligned TIMEPULSE

The following example shows a 60s, falling edge triggered TIMEPULSE aligned to UTC Time

Parameter values			
Pulse Mode	- 1 – falling		
Pulse Period [ms]	60000	Pulse Length [ms]	1
Time Source	0 – UTC		
Cable Delay [ns]	50	User Delay [ns]	0

Table 43: 60s UTC aligned Timepulse settings

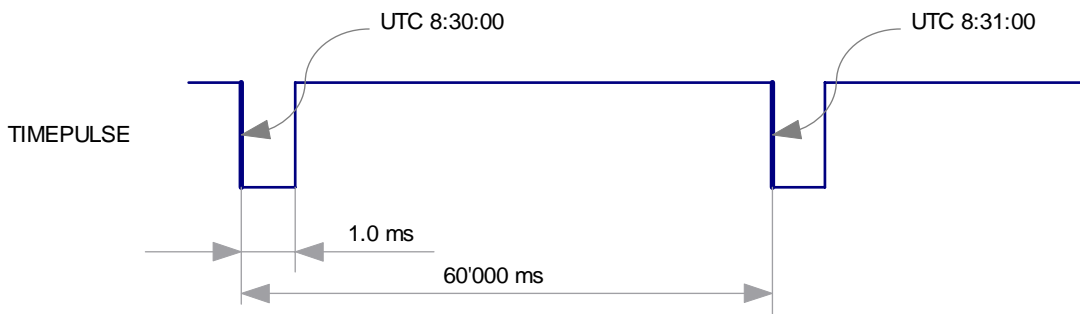

Figure 89: 60s TIMEPULSE Output Signal



## 4.7.2 Time Mode

*This section only applies to LEA-4T modules.*

LEA-4T modules support a special **Time Mode** for increased time accuracy. The ANTARIS®4 is designed only for stationary antenna setup.

The **Time Mode** features three different settings. When the **Time Mode** is disabled, the receiver works like a standard PVT receiver. If high timing accuracy is required and the fixed antenna position is not known, set the **Time Mode** to 'survey-in'. In this mode the ANTARIS®4 GPS receivers averages the position measurements over a long period of time until a predefined standard deviation is achieved. Afterwards the receiver will be automatically set to fixed Mode and the Timing features will be activated.

When the position of the fixed GPS Antenna is well known (i.e. surveyed position), set the **Time Mode** to 'fixed Mode' and fill out X-, Y-, Z- Position parameter in ECEF including the standard deviation of the position.

Parameter	Description	
<b>Time Mode</b>	'disabled'	<b>Time Mode</b> disabled (standard GPS positioning setting)
	'survey-in'	<b>Time Mode</b> activated, but the timing features are still inactive as the current position is not yet defined/ known. When it's measured position is accurate enough, the receiver will be automatically set to fixed Mode and the Timing features will be activated.
	'fixed Mode'	<b>Time Mode</b> activated and current position is defined
<b>Survey-In</b>		
Minimum observation Time	Minimum observation Time for activating timing features.	
Required position standard deviation	Required Standard deviation for activating timing features.	
<b>Fixed Time Mode True Position</b>		
X, Y, Z	X-, Y-, Z- Position parameter in ECEF	
Standard deviation	Standard deviation of the fixed antenna position	

**Table 44: Time Mode Parameter description**

The status information about 'Survey-In' can be found in UBX -. TIM (Timing) – SVIN (Survey-In).

- 🔔 **Note** Timing receiver also supports timing with only one SV. To allow it, change MinSV in UBX – CFG (Config) - NAV2 (Navigation 2) to 1.

### 4.7.3 Timemark

*This section only applies to LEA-4T modules.*

ANTARIS®4 GPS Receiver can be used for time measurements with a sub millisecond resolution using the external interrupt (EXTINT0). The Timemark function can be enabled with UBX – CFG – TM (for firmware version <5.00) or UBX – CFG – TM2 (for firmware version ≥ 5.00).

The results are transmitted via serial port with the UBX – TIM – TM/TM2 messages including time of the last Timemark time source, validity, number of marks, delta time and a quantization error.

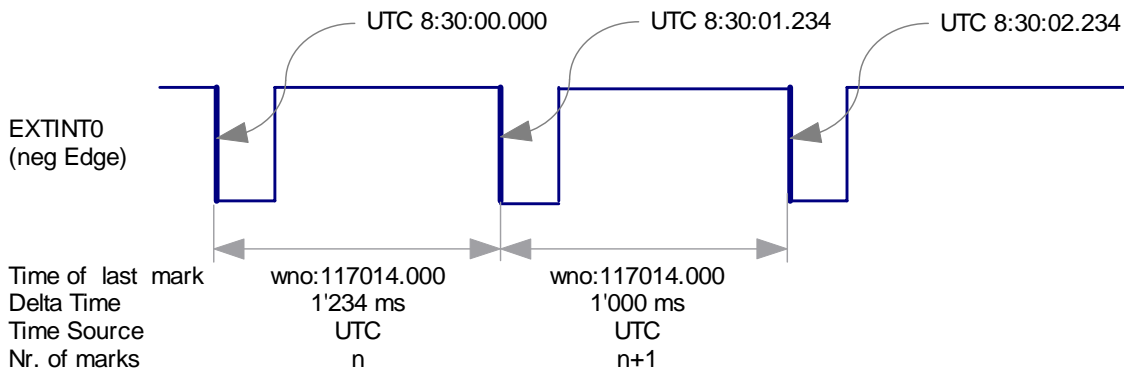

**Figure 90: Timemark example**

## 4.8 Receiver Configuration

### 4.8.1 Configuration Concept

The ANTARIS®4 GPS Technology is fully configurable with UBX protocol configuration messages (message class UBX-CFG). The configuration of the receiver can be changed during normal operation mode. The configuration data is automatically stored to the current configuration section and becomes immediately active (see *Figure 91*). The ANTARIS®4 GPS core always uses the current configuration.

The settings from the current section will only become permanent settings if they are saved to the permanent configuration section with a 'SAVE' command. The permanent settings are copied to the current section after a start-up or whenever a 'LOAD' command is received. The 'CLEAR' command erases the settings in the permanent section but not the current section.

**Note** The 'SAVE', 'LOAD' and 'CLEAR' commands can be sent to the receiver with an UBX-CFG-CFG message.

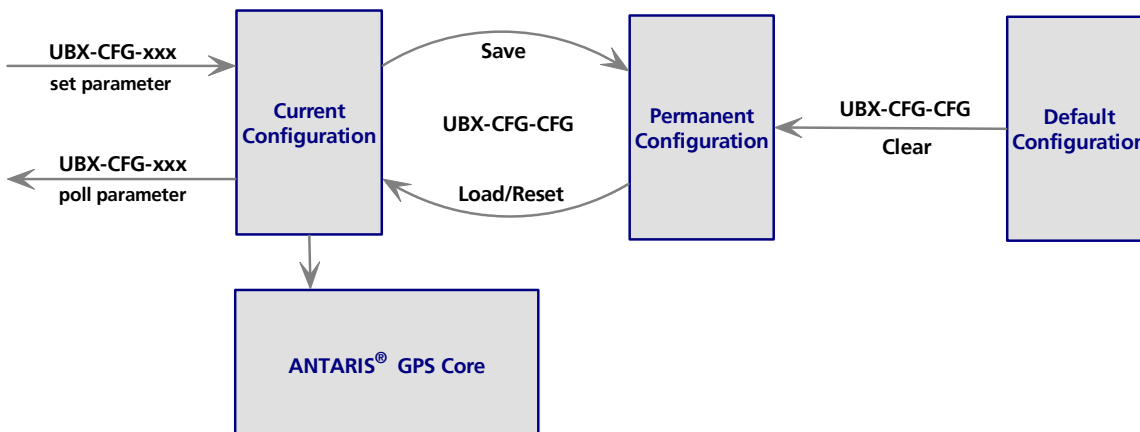

Figure 91: Configuration concept

Low Cost receivers also offer the possibility to choose a configuration with pin settings (GPSMODE pins). For further information refer to *Section 4.8.2*.

#### 4.8.1.1 Configuration Storage Media

The configuration is stored in the on-chip battery backup RAM for Low Cost Receivers or the FLASH memory for Programmable Receivers. The stored configuration will be loaded at every restart.

An overview of the memory/storage media:

Memory/Storage Media	Specifics
SRAM (Static RAM)	Volatile RAM, stored data gets lost after a power down.
On-chip BBR (battery backup RAM) (Low Cost Receivers)	Volatile RAM, stored data remain only if a Backup Battery is applied. Also used to store receiver configuration and GPS data.
FLASH (Programmable GPS receivers)	Non Volatile RAM, used to store data and receiver configuration .
ROM (Read Only Memory)	ROM holds the firmware of the GPS receiver
EEPROM (NEO-4S only)	Non Volatile RAM, used to store data, receiver configuration. Only available for NEO-4S. Requires connecting the EEPROM via SPI to NEO-4S.

Table 45: Memory/ Storage Media on

### 4.8.1.2 Organization of the Configuration Sections

The configuration is divided into several sub-sections. Each of these sub-sections corresponds to one or several UBX-CFG messages.

Sub-Section		CFG - Messages	Description
0	PRT	UBX-CFG-PRT	Port settings
1	MSG	UBX-CFG-MSG UBX-CFG-NMEA	Message settings (enable/disable, update rate)
2	INF	UBX-CFG-INF	Information output settings (Errors, Warnings, Notice, Test etc.)
3	NAV DAT RATE TP TM	UBX-CFG-NAV2 UBX-CFG-DAT UBX-CFG-RATE UBX-CFG-TP UBX-CFG-TM2	Navigation Parameter Receiver Datum Measurement and Navigation Rate setting Timepulse Settings Timemark Settings
4	RXM SBAS	UBX-CFG-RXM UBX-CFG-SBAS	RXM SBAS
5	FXN	UBX-CFG-FXN	Parameters of FixNOW™ mode
6-9	EKF Configuration	UBX-CFG-EKF	EKF Configuration (TIM-4R only)
10	ANT	UBX-CFG-ANT	Antenna Configuration
11	Reserved	N/A	Reserved
12-15	User0 – User3	N/A	

**Table 46: Configuration messages**

**Note** The sub-sections can be saved, loaded and cleared individually. If a sub-section is cleared, saved or loaded with one single UBX-CFG-CFG message, the ,CLEAR' command will be executed first, then the ,SAVE' and finally the ,LOAD' command.

### 4.8.1.3 Change Configuration temporarily

To change the configuration temporarily, any of the UBX configuration messages can be sent over the Serial Communication Port. The receiver will change its configuration immediately after receiving the message. However it will not be stored in non-volatile memory.

#### 4.8.1.4 Change Configuration permanently

To change a configuration permanently on the receiver, the configuration parameters must have been previously stored in order to be available at startup. Therefore any permanent change of configuration must be saved in the battery backup RAM for Low Cost receivers or FLASH for Programmable Receivers.

To store a configuration select the UBX – CFG (Config) – CFG (Configuration) save command in u-center AE and send the message to the receiver by pressing the send button (Send).

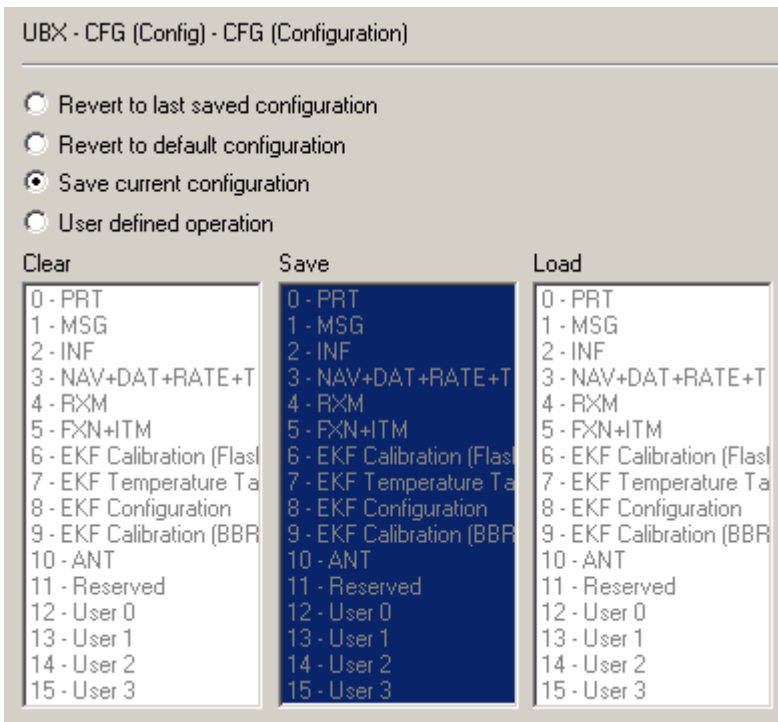

Figure 92: Saving a configuration section

**Note** Use the <ctrl> + <left click> to deselect the last selection, if you choose "user defined".

#### 4.8.1.5 Loading a Configuration

Generally there is no need to manually load configuration settings since they are automatically loaded at startup. The ability to force a load of the settings can be useful if you changed some settings (without saving them) and want to reset the configuration to the last saved configuration. To do this select the requested sections in the load box and send the message to the receiver.

#### 4.8.1.6 Clear a Configuration permanently

Clearing a configuration can be useful if you want to reset to the factory default state. You have to load them afterwards to become effective.

**Note** This operation only clears the configuration Memory. It doesn't reapply defaults. You need to do a „Load“ or restart the system in order to load the defaults.

**Note** When selecting sections in the Clear, Save and Load box Configuration is first cleared then saved and finally reloaded.

## 4.8.2 GPSMODE Pin Configuration (ROM only / Low Cost Receivers)

This section only applies to TIM-4A/LEA-4A and TIM-4S/LEA-4S.

### 4.8.2.1 Start-Up Pin Configuration (GPSMODE Pins)

The start-up configuration of ROM based receivers like TIM-4A/LEA-4A or TIM-4S/LEA-4S is defined by the status of the GPSMODE pins after system reset. The default configuration can be altered by pulling up or down a number of so-called GPSMODE pins (see Section 4.8.2.1 and Table 47) Alternatively, the system can be configured through message commands passed through the serial interface after start-up. Figure 93 depicts the start-up procedure of ANTARIS<sup>®</sup>4 GPS receivers.

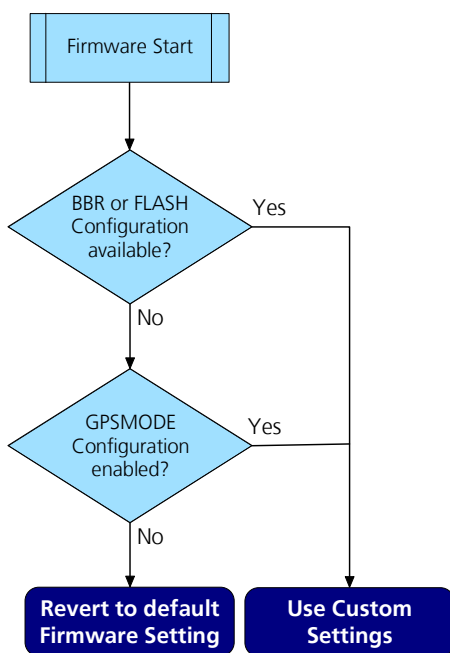

Figure 93: ANTARIS<sup>®</sup>4 GPS Technology Start-Up Procedure

**Note** The start-up configuration can be changed at any time sending appropriate configuration commands over serial port.

TIM and LEA receivers support only a subset of all GPSMODE configurations of the ANTARIS<sup>®</sup>4 Chipset due to limited pins available on the module.

Pin	Function	TIM-4A/ TIM-4S	LEA-4A	LEA-4S
GPSMODE2	GPS sensitivity settings	●	●	
GPSMODE3		●		
GPSMODE23				●
GPSMODE5	Serial I/O configuration	●	●	●
GPSMODE6		●	●	●
GPSMODE7	USB Power Mode <sup>18</sup>		●	●
GPSMODE12	Serial I/O configuration	●		

●: Available

Table 47: Available GPSMODE's

<sup>18</sup> Redefined GPSMODE function for ANTARIS<sup>®</sup>4 – **caution** when implementing into ANTARIS<sup>®</sup> designs e.g. LEA-LA

### 4.8.2.2 Sensitivity Settings

For LEA-4A, TIM-4A and TIM-4S:

TIM-4x	LEA-4A	GPSPMODE3 [PU]	GPSPMODE2 [PU]	Description
●		0	0	Auto
●		0	1	Fast Mode
●	●	1	0	Normal sensitivity mode
●	●	1	1	High sensitivity mode

●: Available

**Table 48: Sensitivity Settings with GPSPMODE pins (for TIM-4x and LEA-4A)**

For LEA-4S:

LEA-4S	GPSPMODE23 [PU]	Description
●	0	Auto
●	1	High sensitivity mode

●: Available

**Table 49: Sensitivity Settings with GPSPMODE pins (for LEA-4S)**

### 4.8.2.3 Serial I/O Configuration

To handle the serial I/O configuration with GPSPMODE pins, there are message sets defined and **all protocols are enabled on all ports** (for input and output).

TIM	LEA	GPSPMODE			USART1/ USB Output Protocol / Baudrate (kBaud)	USART2	Messages	Information Messages (UBX INF)	Information Messages (NMEA TXT)
		12 PU	6 PU	5 PD					
●		0	0	0	UBX / 57.6	NMEA / 19.2	High	User, Notice, Warning, Error	
●		0	0	1	UBX / 38.4	NMEA / 9.6	Med	User, Notice, Warning, Error	
●		0	1	0	UBX / 19.2	NMEA / 4.8	Low	User, Notice, Warning, Error	
●		0	1	1	- / Auto	- / Auto	Off	None	None
●	●	1	0	0	NMEA / 19.2	UBX / 57.6	High		User, Notice, Warning, Error
●	●	1	0	1	NMEA / 4.8	UBX / 19.2	Low		User, Notice, Warning, Error
●	●	1	1	0	<b>NMEA / 9.6 (default)</b>	<b>UBX / 38.4 (default)</b>	<b>Med</b>		<b>User, Notice, Warning, Error</b>
●	●	1	1	1	UBX / 115.2	NMEA / 19.2	Debug	All	

●: Available/  : Default setting

**Table 50: Serial I/O configuration with GPSPMODE pins**

All available USART ports accept input messages in all three supported protocols (NMEA, RTCM, and UBX) at the configured baud rate. Input messages of all three protocols can be arbitrarily mixed. Response to a query input message will always use the same protocol as the query input message.

The following message settings are used in the *Table 50* above:

Message Set	Protocol	Message Class	Messages
Low	NMEA	Standard	GGA, RMC
	UBX	NAV	SOL, SVINFO
Medium	NMEA	Standard	GGA, RMC, GSA, GSV, GLL, VTG, ZDA
	UBX	NAV	SOL, SVINFO, POSECEF, POSLLH, STATUS, DOP, VELECEF, VELNED, TIMEGPS, TIMEUTC, CLOCK
High	NMEA	Standard	GGA, RMC, GSA, GSV, GLL, VTG, ZDA, GRS, GST
		Proprietary	PUBX00, PUBX03, PUBX04
	UBX	NAV	SOL, SVINFO, POSECEF, POSLLH, STATUS, DOP, VELECEF, VELNED, TIMEGPS, TIMEUTC, CLOCK
		MON	SCHD, IO, IPC
Debug	NMEA	Standard	GGA, RMC, GSA, GSV, GLL, VTG, ZDA, GRS, GST
		Proprietary	PUBX00, PUBX03, PUBX04
	UBX	NAV	SOL, SVINFO, POSECEF, POSLLH, STATUS, DOP, VELECEF, VELNED, TIMEGPS, TIMEUTC, CLOCK
		MON	SCHD, IO, IPC
		RXM	RAW

: Default setting

**Table 51: ROM message set**

#### 4.8.2.4 USB Power Mode

A4

GPSPMODE7 defines the USB power mode of the module.

A “bus powered” device is powered from the USB bus and is allowed to draw up to 100mA from the USB bus. The power mode is reported to the USB host, as i.e. the device classifies itself as a “Low-power bus-powered function” with no more than one USB power unit load. A “self powered” device has it’s own power source.

To change USB settings use UBX-CFG-USB message.

TIM	LEA	GPSPMODE7 [PU]	Description
	●	0	USB device is bus-powered (max. current limit 100 mA)
	●	1	<b>USB device is self-powered (Default)</b>

●: Available / : Default setting

**Table 52: USB Power Modes**



## 4.9 System Functions

### 4.9.1 Reset Options

The ANTARIS®4 GPS Technology distinguishes between four types of reset. An external hardware reset (by pulling open drain **RESET\_N** pin low), two resets are controlled software resets and one is an asynchronous software reset, which are used to shut down and restart parts or the whole receiver.

The forced reset performs an immediate hardware reset similar to the external hardware reset.

Upon every software reset, it's possible to define the type of start-up scenario (Hotstart, Warmstart, Coldstart). This start-up scenario defines which GPS data is reused and which is cleared (e.g. the ephemeris data is cleared for a Warmstart).

#### 4.9.1.1 Controlled Reset

The Controlled Reset waits until the system is in the background task (all tasks are idle). It then broadcasts a GPS Stop Event and a System Stop Event. After that the software is started again. This means that the configuration from BBR (battery backup RAM) or Flash (depending on the firmware used) is reloaded.

#### 4.9.1.2 Controlled GPS only Reset

The Controlled GPS only Reset waits until all GPS Tasks are idle (not running or pending). It then resets the Navigation and Tracking Engine and starts them again. The system is not fully restarted from scratch.

#### 4.9.1.3 Forced Reset (Watchdog)

The Forced Reset is an asynchronous reset that immediately stops all tasks that are running and resets the hardware. No System Stop or GPS Stop Event is sent. This reset is equivalent to an externally supplied reset signal.

### 4.9.2 RESET\_N - Reset signal generation and use

All ANTARIS®4 modules contain a Voltage detector connected to VCC to RESET the GPS receiver, when the supply voltage drops below 2.4V.

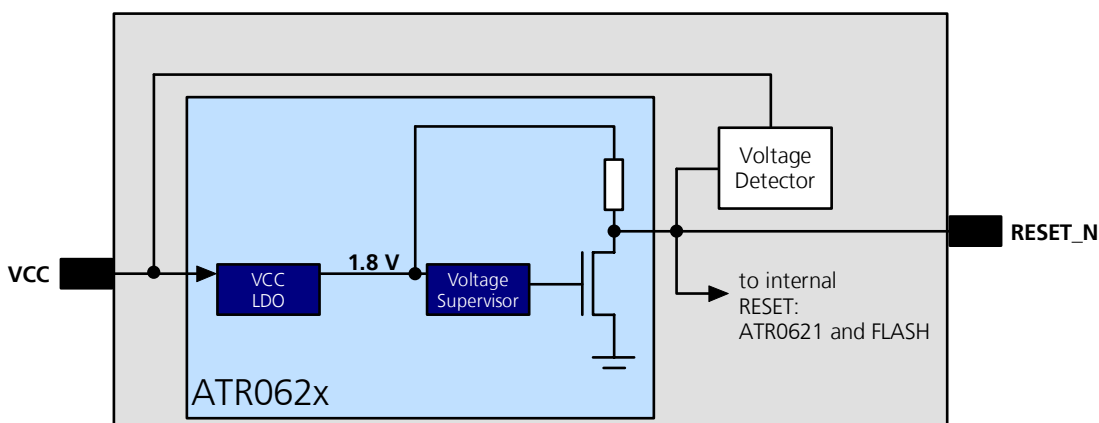

Figure 94: RESET generation

**RESET\_N** is an open drain I/O pin, thus one can apply external logic to drive the **RESET\_N** signal low to activate a hardware reset of the system. In most applications, the use of the **RESET\_N** pin is not required since ANTARIS 4 GPS modules contain an internal reset chip. Leave **RESET\_N** unconnected if not used.

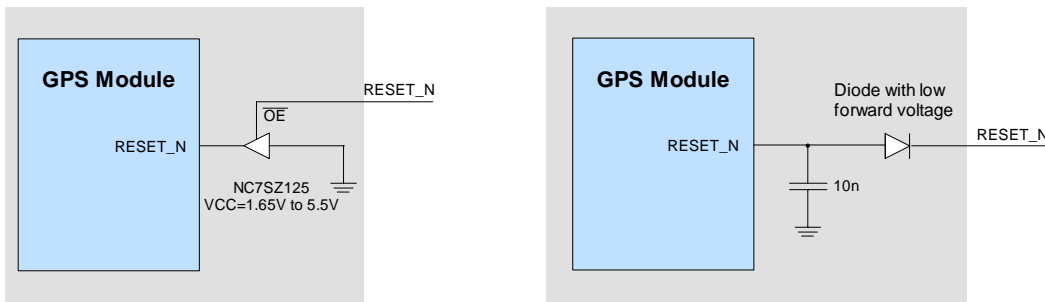

Figure 95: Examples for wiring RESET\_N

**Warning** Do not drive RESET\_N high. The maximum output voltage at RESET\_N is limited to 1.8 V. RESET\_N is sensitive even to short voltage spikes. Keep this signal clean if routed outside the module.

NEO-4S can only be reset by either cycling the power supply (VCC) or by sending a UBX-CFG-RST command as the RESET\_Npin is not available on NEO-4S.

### 4.9.3 BOOT\_INT– Boot Mode Selection

*This section does not apply to ROM based receivers.*

**BOOT\_INT** is used to set the boot mode of the ANTARIS®4 GPS Receiver. By default the receiver will boot in normal GPS mode. If there are corrupted data in FLASH, it may be necessary to boot the receiver in test mode by pulling **BOOT\_INT** high during a power cycle or hardware reset to update the firmware.

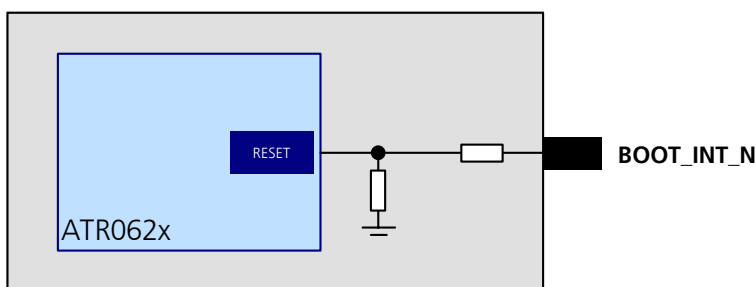

Figure 96: BOOT\_INT, Internal connection

**Note** This Pin is only needed if a firmware upgrade failed and therefore the firmware image is corrupt. Leave **BOOT\_INT** unconnected if not used.

**Note** It's advisable to foresee a jumper between BOOT\_INT\_N and VCC. For Low Cost Receivers this signal is only used for production tests at u-blox, hence no jumper is required.

### 4.9.4 EXTINT - External Interrupt Pin

**EXTINT0** (and optional **EXTINT1**) is an external interrupt pin. This pin is used in standard configuration to initiate a position fix in the FixNOW™ Mode. A rising edge at **EXTINT** wakes up the module and initiates a position fix calculation. Using the *ANTARIS®4 Software Customization Kit*, **EXTINT** can initiate external interrupts to custom functions.

**Note** **EXTINT** pins are internally pulled up to VDD18, leave EXTINT unconnected if not used.

### 4.9.5 System Monitoring

The ANTARIS<sup>®</sup> 4 GPS Receiver provides System Monitoring functions that allow the operation of the embedded processor and associated peripherals to be supervised. These System Monitoring functions are being output as part of the UBX protocol, class 'MON'. The information available from the system monitoring functions is:

1. Software Version
2. Hardware Version
3. Current system CPU load
4. Maximum stack usage since last reset
5. Last exception (type/registers/ stack dump)
6. Target (USART/SPI) specific values:
  - Number of bytes received
  - Number of bytes transmitted
  - Number of parity errors
  - Number of framing errors
  - Number of overrun errors
  - Number of break conditions
  - Number of bytes received, that were not part of any of the supported protocols
  - Current transmission buffer usage
  - Maximum transmission buffer usage since last reset
  - Number of bytes pending for transmission
  - Current reception buffer usage
  - Maximum reception buffer usage since last reset
  - Number of received and correctly decoded messages for each supported protocol

Please refer to the *ANTARIS<sup>®</sup> 4 Protocol Specifications [9]*. For more information on individual system monitoring functions.

### 4.10 Dead Reckoning enabled GPS module (DR module)

For Dead Reckoning enabled GPS module description please refer to *LEA-4R/TIM-4R System Integration Manual [7]*.

## 5 Product Handling

**Note** As all ANTARIS<sup>®</sup>4 products are **LEAD FREE (RoHS compliant)**.

### 5.1 Packaging

The ANTARIS<sup>®</sup>4 GPS Modules are delivered as hermetically sealed reeled tapes in order to enable efficient production, production lot set-up and tear-down.



Figure 97: Reeled ANTARIS<sup>®</sup>4 GPS Receiver modules

#### 5.1.1 Reels

The ANTARIS<sup>®</sup>4 GPS Modules are deliverable in two quantities. A 100pcs and a 250pcs reel. The dimensions of the reel are shown in *Figure 98*.

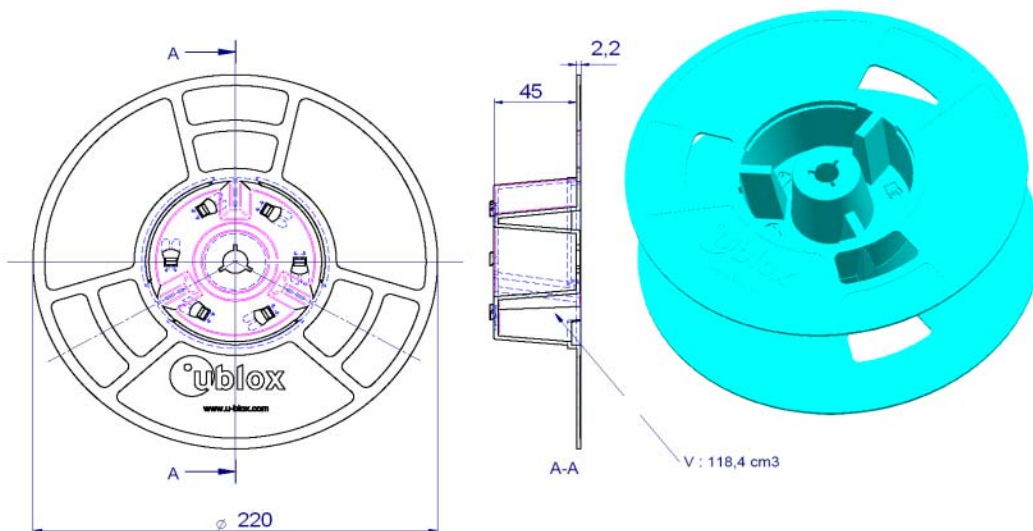
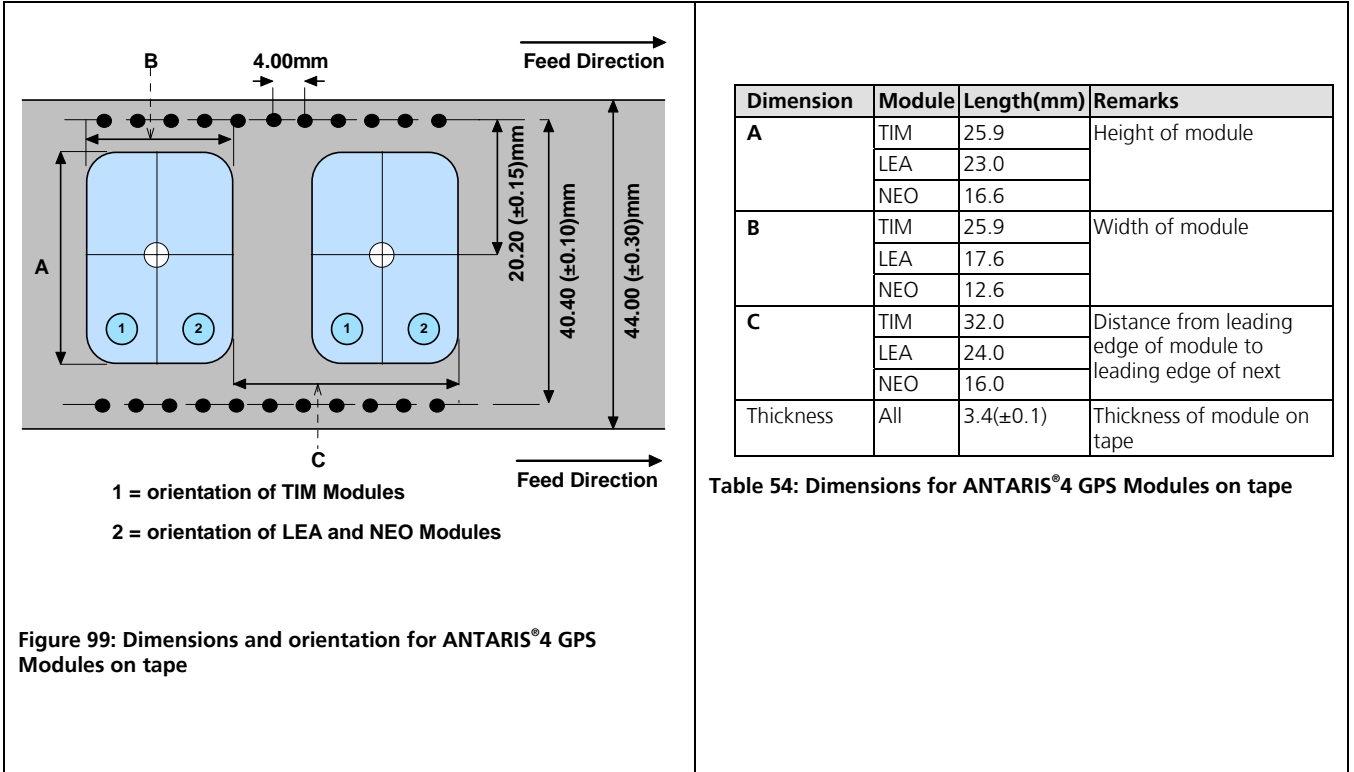

Figure 98: Dimension of reel for 100 or 250 pieces (dimensions unless otherwise specified in mm)

### 5.1.2 Tapes

The dimensions and orientations of the tapes for the TIM-4x, LEA 4x and NEO-4x GPS Modules are specified in Figure 99 and Table 54.



## 5.2 Shipment, Storage and Handling

A4

### 5.2.1 Handling

The ANTARIS®4 GPS Module is designed and packaged to be processed in an automatic assembly line. The module is shipped in Tape-and-Reel.

- ! Warning** The component contains highly sensitive electronic circuitry. Handling the ANTARIS®4 GPS Receiver without proper ESD protection may destroy or damage the GPS modules permanently.
- ! Warning** According to JEDEC ISP, the ANTARIS®4 GPS Modules are moisture sensitive devices. Appropriate handling instructions and precautions are summarized in Sections 5.2.2 to 5.2.5. Read them carefully to prevent permanent damages due to moisture intake.

### 5.2.2 Shipment

A4

The ANTARIS®4 GPS Modules are delivered on Tape-and-Reels in a hermetically sealed package ("dry bag") to prevent moisture intake and protection against electrostatic discharge. To prevent physical damages, the reels are individually packed in carton boxes.

The dry bag provides a JEDEC compliant MSD label (Moisture Sensitive Devices) describing the handling requirements to prevent humidity intake.



Figure 100: Applicable MSD Label (See Section 3.1 for baking instructions)

### 5.2.3 Storage

Shelf life in sealed bag is 12 months at <math><40^{\circ}\text{C}</math> and <math><90\%</math> relative humidity.

### 5.2.4 Handling

A humidity indicator card and a desiccant bag to absorb humidity are enclosed in the sealed package. The parts are shipped on tape-and-reel in a hermetically sealed package. If no humidity has been drawn, the three fields in the humidity indicator card indicate blue color.

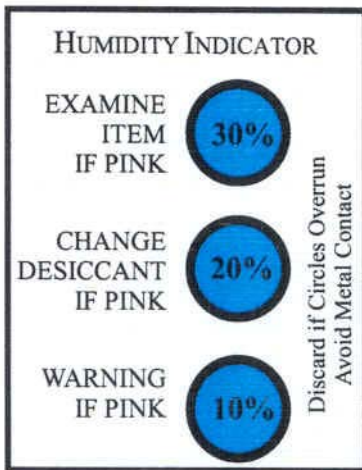

**Figure 101: Humidity Indicator Card, good condition**

### 5.2.5 Floor Life

For products with moisture sensitivity level 4, the floor life is 72 hours, or precisely three days. Under factory floor temperature and humidity conditions (<30°C, <60% relative humidity), the parts must be processed and soldered within this specified period of time.

Once the sealed package of the reel is opened and the parts exposed to humidity, they need to be processed within 72 hours (precisely three days) in a reflow soldering process. If this time is exceeded, or the sticker in the sealed package indicates that the goods have been exposed to moisture, the devices need to be pre-baked before the flow solder process. Please refer to *Section 5.3* for instructions on how to pre-bake the components.

## 5.3 Processing

### 5.3.1 Moisture Preconditioning

Both encapsulant and substrate materials absorb moisture. JEDEC specification J-STD-020 must be observed to prevent cracking and delamination associated with the "popcorn" effect during solder reflow. The popcorn effect can be described as miniature explosions of evaporating moisture. Baking before processing is required in following cases:

- Humidity indicator card: At least one circular indicator is no longer blue
- Floor life or environmental requirements after opening the seal is opened has been exceeded, e.g. exposure to excessive seasonal humidity.

#### Recommended baking procedure:

Duration: 48 hours

Temperature: 125°C

Humidity: Below 5%. Desiccant must be placed into the oven to keep humidity low.

Oven: Convection flow oven. Also put desiccant pack into the oven for dehydration.

After work: Put the baked components with desiccant and moisture indicator into a humidity proof bag and use a vacuum hot barrier sealing machine for sealing if not processed within specified floor time. Storage in a nitrogen cabinet or dry box is also a possible approach to prevent moisture intake.

**! Warning** Do not attempt to bake the ANTARIS®4 GPS Modules contained in tape and rolled up in reels. If you need to bake the ANTARIS®4 GPS Modules quickly at 125°C for 48 hours, remove them from the belt and place them individually onto the oven tray.

**Note** A repeated baking process will reduce the wetting effectiveness of the pad contacts. This applies to all SMT devices.

### 5.3.2 Soldering Paste

Use of "No Clean" soldering paste is strongly recommended, as it does not require cleaning after the soldering process has taken place. The paste listed in the example below meets these criteria.

Soldering Paste: LFSOLDER TLF-206-93F (Tamura Kaken (UK) Ltd.)

Alloy specification: Sn 95.5/ Ag 3.9/ Cu 0.6 (95.5% Zinc/ 0.6 % Silver/ 0.6% Copper)

Melting Temperature: 216 - 221°C

Stencil Thickness: 150 µm for base boards

The final choice of the soldering paste depends on the approved manufacturing procedures.

The paste-mask geometry for applying soldering paste should meet the recommendations in section 3.6.2.

**Note** The quality of the solder joints on the connectors ('half vias') should meet the appropriate IPC specification.



### 5.3.3 Reflow Soldering

**A convection type-soldering oven is strongly recommended** over the infrared type radiation oven. Convection heated ovens allow precise control of the temperature and all parts will be heated up evenly, regardless of material properties, thickness of components and surface color.

Consider the "IPC-7530 Guidelines for temperature profiling for mass soldering (reflow and wave) processes, published 2001".

#### Preheat Phase

Initial heating of component leads and balls. Residual humidity will be dried out. Please note that this preheat phase will not replace prior baking procedures.

- Temperature rise rate: 1 - 4°C/s      If the temperature rise is too rapid in the preheat phase it may cause excessive slumping.
- Time: 60 – 120 seconds      If the preheat is insufficient, rather large solder balls tend to be generated. Conversely, if performed excessively, fine balls and large balls will be generated in clusters.
- End Temperature: 150 - 200°C      If the temperature is too low, non-melting tends to be caused in areas containing large heat capacity.

#### Heating/ Reflow Phase

The temperature rises above the liquidus temperature of 216 - 221°C. Avoid a sudden rise in temperature as the slump of the paste could become worse.

- Limit time above 220°C liquidus temperature: 20 - 40s
- Peak reflow temperature: 230 - 250°C

#### Cooling Phase

A controlled cooling avoids negative metallurgical effects (solder becomes more brittle) of the solder and possible mechanical tensions in the products. Controlled cooling helps to achieve bright solder fillets with a good shape and low contact angle.

- Temperature fall rate: max 3°C / s

**Note** To avoid falling off, the ANTARIS®4 GPS Module should be placed on the topside of the motherboard during soldering.

The final soldering temperature chosen at the factory depends on additional external factors like choice of soldering paste, size, thickness and properties of the base board, etc. Exceeding the maximum soldering temperature in the recommended soldering profile may permanently damage the module.

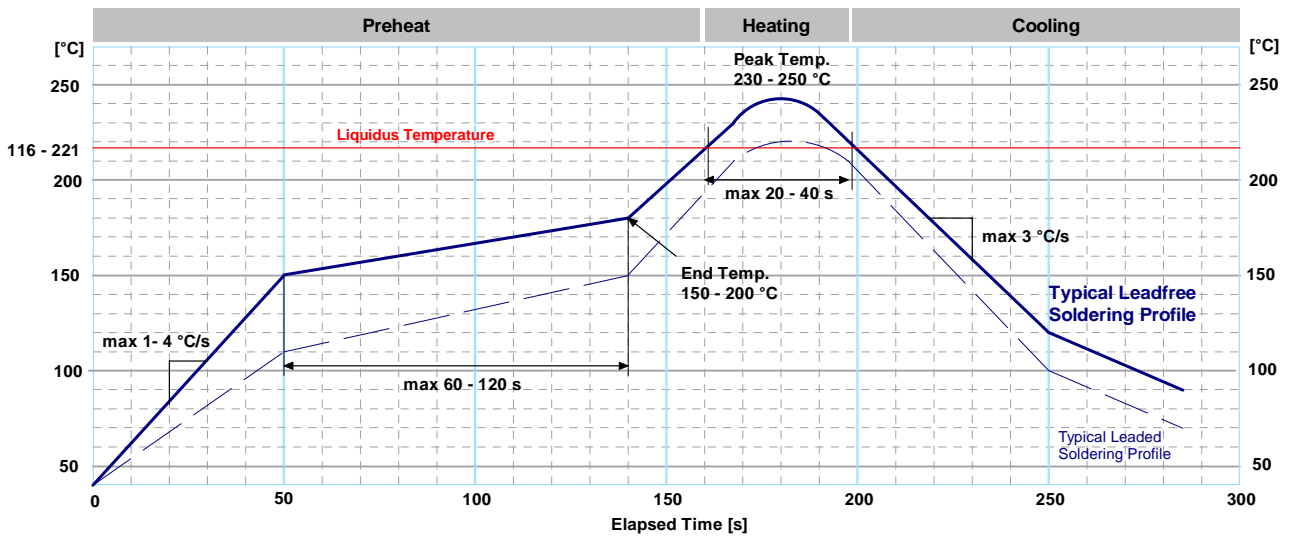

Figure 102: Recommended soldering profile

**Note** When soldering **leadfree** (ANTARIS®4) **modules in a leaded process**, check the following temperatures:

- PB- Technology Soaktime: 40-80sec
- Time above Liquidus: 40-90 sec
- Peak temperature: 225-235 °C

These Peak temperatures is around 10 degree higher than the recommended standard leads process on ANTARIS® products.

**Note** The ANTARIS® modules must not be soldered with a damp heat process.

### 5.3.4 Optical Inspection

After soldering the ANTARIS®4 GPS Module, consider an optical inspection step to check whether:

- ANTARIS®4 GPS Module is properly aligned and centered over the pads
- All pads are properly soldered
- No excess solder has created contacts to neighboring pads, or possibly to pad stacks and vias nearby.

### 5.3.5 Cleaning

In general, cleaning the populated modules is strongly discouraged. Residuals, which are underneath the ANTARIS®4 GPS Modules, cannot be removed easily with a washing process.

- Cleaning with water will lead to capillary effects where water is absorbed in the gap between the baseboard and the ANTARIS®4 GPS Module. The combination of residuals of soldering flux and encapsulated water leads to short circuits or resistor-like interconnections between neighboring pads. Water will also damage the sticker and the ink-jet printed text.
- Cleaning with alcohol or a similar organic solvent will likely flood soldering flux residuals into the two housings, which is a place not accessible for post-washing inspection. The solvent will also damage the sticker and the ink-jet printed text.
- Ultrasonic cleaning will damage an ANTARIS®4 GPS Receiver permanently, in particular the quartz oscillators.

The best approach is to consider using a "no clean" soldering paste and eliminate the cleaning step past the soldering.

### 5.3.6 Repeated Reflow Soldering

Only a single reflow soldering process is encouraged for boards with an ANTARIS®4 GPS Module populated on it. Reason: Risk of falling off due to high weight in relation to the adhesive properties of the solder.

### 5.3.7 Wave Soldering

Base boards with combined through-hole technology (THT) components and surface-mount technology (SMT) devices require a wave soldering to solder the THT components. Only a single wave soldering process is encouraged for boards with an ANTARIS®4 GPS Module populated on it.

### 5.3.8 Hand Soldering

Hand soldering is allowed. Use a Soldering iron temperature setting "7" which is equivalent to 350°C and carry out the hand soldering according to the IPC recommendations / reference documents IPC7711.

Place the ANTARIS®4 GPS Module precisely on the pads. Start with a cross-diagonal fixture soldering (e.g. pins 1 and 16), and then continue from left to right.

### 5.3.9 Rework

The ANTARIS®4 GPS Module can be unsoldered from the baseboard. Use desoldering braid made of copper. Avoid overheating the ANTARIS®4 GPS Modules.

A vacuum solder sucker is not recommended as solder residuals may remain in the gap below the module.

After all solder has been removed from all pads, lift the component carefully. Continue unsoldering carefully if the ANTARIS®4 GPS Module does still stick. After the module is removed, clean the pads before placing and hand-soldering a new module.

- ! Warning** Never attempt a rework on the module itself, e.g. replacing individual components. Such actions will terminate warranty coverage immediately.

### 5.3.10 Conformal Coating

Certain applications employ a conformal coating of the PCB using HumiSeal® or other related coating products.

These materials affect the HF properties of the GPS module and it is important to prevent them from flowing into the module.

The RF shields do not provide 100% protection for the module from coating liquids with low viscosity, therefore care is required in applying the coating.

☞ **Note** Conformal Coating of the module will void the warranty.

### 5.3.11 Casting

If casting is required, use viscose or another type of silicon pottant. The OEM is strongly advised to qualify such processes in combination with the ANTARIS®4 GPS Module before implementing this in the production.

☞ **Note** Casting will void the warranty.

### 5.3.12 Grounding Metal Covers

Attempts to improve grounding by soldering ground cables, wick or other forms of metal strips directly onto the EMI covers is done at the customer's own risk. The numerous ground pins should be sufficient to provide optimum immunity to interferences and noise.

☞ **Note** u-blox makes no warranty for damages on the ANTARIS®4 GPS Module caused by soldering metal cables or any other forms of metal strips directly onto the EMI covers.

### 5.3.13 Use of any Ultrasonic Processes

Some components on the ANTARIS®4 GPS Module are sensitive to Ultrasonic Waves. Use of any Ultrasonic Processes (cleaning, welding etc.) may cause damage to the GPS Receiver.

☞ **Note** u-blox offers no warranty against damages to the ANTARIS®4 GPS Module caused by any Ultrasonic Processes.

## 6 Product Testing

### 6.1 u-blox In-Series Production Test

A4

u-blox focuses on high quality for its products. To achieve a high standard it's our philosophy to supply fully tested units. Therefore at the end of the production process, every unit is tested. Defective units are analyzed in detail to improve the production quality.

This is achieved with automatic test equipment, which delivers a detailed test report for each unit. The following measurements are done:

- Digital self-test (Software Download, verification of FLASH firmware, etc.)
- Measurement of voltages and currents
- Measurement of RF characteristics (e.g. C/No)

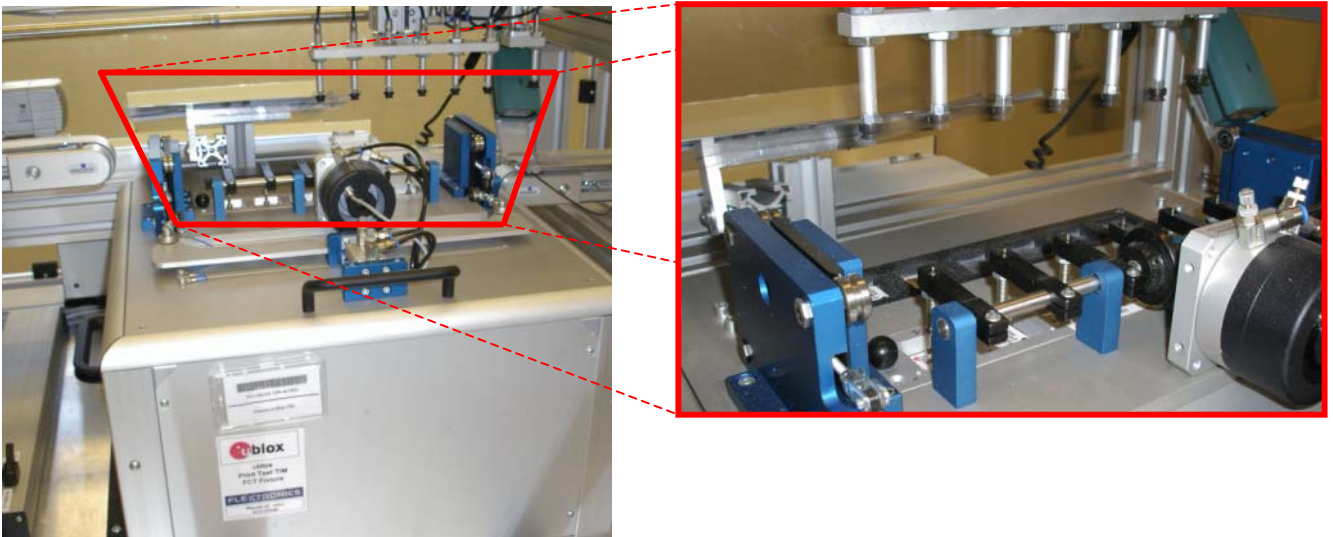

Figure 103: Automatic Test Equipment for Module Tests

### 6.2 Test Parameters for OEM Manufacturer

Because of the testing done by u-blox (with 100% coverage), it is obvious that an OEM manufacturer doesn't need to repeat firmware tests or measurements of the GPS parameters/characteristics (e.g. TTFF) in their production test.

An OEM Manufacturer should focus on

- Overall sensitivity of the device (including antenna, if applicable)
- Communication to a host controller

## 6.3 System Sensitivity Test

The best way to test the sensitivity of a GPS device is with the use of a 1-channel GPS simulator. It assures reliable and constant signals at every measurement.



**Figure 104: 1-channel GPS simulator**

u-blox recommends the following Single-Channel GPS Simulator:

- Spirent GSS6100  
Spirent Communications Positioning Technology  
(previously GSS Global Simulation Systems)

[www.positioningtechnology.co.uk](http://www.positioningtechnology.co.uk)

### 6.3.1 Guidelines for Sensitivity Tests

1. Connect a 1-channel GPS simulator to the OEM product
2. Choose the power level in a way that the “Golden Device” would report a C/No ratio of 45 dBHz
3. Power up the DUT (Device Under Test) and allow enough time for the acquisition
4. Read the C/No value from the NMEA GSV or the UBX-NAV-SVINFO message (e.g. with u-center AE)
5. Reduce the power level by 10dB and read the C/No value again
6. Compare the results to a “Golden Device” or an ANTARIS®4 GPS EvalKit.

### 6.3.2 ‘Go/No go’ tests for integrated devices

The best test is to bring the device to an outdoor position **with excellent visibility** (HDOP < 3.0). Let the receiver acquire satellites and compare the signal strength with a “Golden Device”.

-  **Note** As the electro-magnetic field of a redistribution antenna is not homogenous, indoor tests are in most cases not reliable. These kind of tests may be useful as a ‘go/no go’ test but not for sensitivity measurements.

## 7 PC Support Tools

### 7.1 Firmware Update

A4

There are several ways to upgrade the firmware

1. Command line tool (ATR062xL.exe)
2. U-center update tool

#### 7.1.1 ATR062xL.exe

A4

The command line tool ATR06xL.exe can be used to upgrade firmware over serial port.

It's possible to write customized batch files to run the firmware upgrade automatically. To run the ATR062xL.exe with a batch file, add a file e.g. udwld.bat to your project directory with the following content according to your PC and GPS receiver setup:

**Example:**

```
Atr062xL.exe -f ANTARIS_Fw_5.00.bin -c COM -p com1 -m UBX 9600
```

There are arguments of the command line tool:

```
-b <baudrate> transfer baud rate (def: 115200)
-c <interface> communication interface (def: COM)
  use COM port for RS232 communication
-e erase thecomplete flash memory even without firmware upgrade
-f <filename> [<address>] firmware image and
  optional address in hex format (def: 0x0100000)
-i <filename> flash definition (def: flash.txt)
-k erase only the space required for the firmware, keep the rest
-l <filename> loader image (def: ATR0620.ldr)
-m <mode> enter production boot mode (def: UBX 57600)
  UBX <baudrate> use UBX protocol RS-232 only
  CTL use RTS / DTR control lines RS-232 only
  PS manual
-p <portname> serial port name
-r [<filename>] verify written firmware, optionally dump readback to file
-M test memory before writing firmware (non-flash only)
-v <n> Set Verbosity Level (range 0 to 5, default 4)
-x suppress progress messages (for use in dumb terminals)
```

## 7.1.2 U-center Update Tool

### 7.1.3 Firmware update with u-center AE

The receiver firmware can be updated with the firmware update function in the Tools Menu of u-center AE. Follow these steps to upgrade the firmware on ANTARIS<sup>®</sup>4 GPS Receiver:

#### 7.1.3.1 Firmware Update via Serial Port (USART)

1. Establish the serial communication between u-center AE and the Receiver.
2. Start the firmware update tool

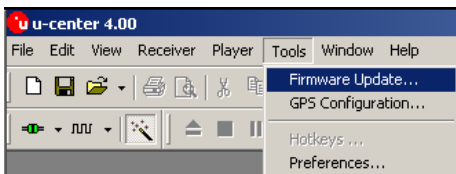
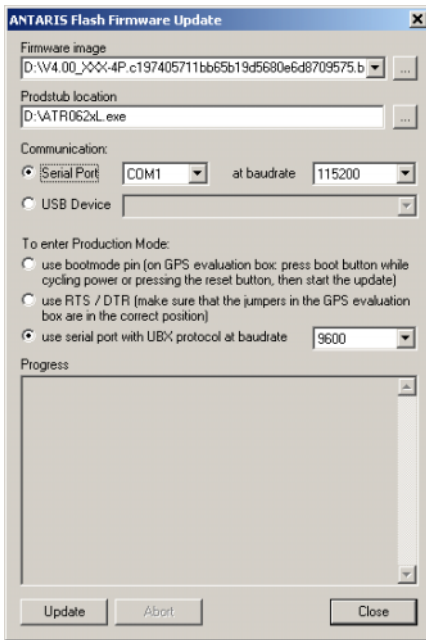

**Figure 105: Screenshot, u-center ANTARIS<sup>®</sup> Edition, Tools Menu**

3. Select the path of the 'prodstub' (ATR062xL.exe for Serial Port Update) and the firmware image.
4. Select the 'Production Mode'. ANTARIS<sup>®</sup>4 based GPS receivers can be put into boot mode by sending a UBX protocol command. If the GPS receiver connected to u-center is configured for UBX protocol input, choose the 'use serial port' option. Otherwise, select 'use bootmode pin' and put the receiver manually into Boot Mode by setting pin **BOOT\_INT** to high.
5. Check the COM port (automatically initialized with the current COM port in use).
6. Select the download baud rate. This is the baud rate used during the firmware download. The default value is 115200 baud. The lower this baud rate, the longer a firmware update takes.
7. If 'Production Mode' is set to 'serial port with UBX protocol', check the UBX protocol baud rate (automatically initialized with the current baud rate in use). The UBX protocol baud rate is only used to enter the download process.



8. Press 'Update' Button to start download.



**Figure 106: Screenshot, u-center Firmware; Update Tool settings for Serial Port Update**

## 7.2 Using u-center ANTARIS® Edition

u-center ANTARIS® Edition (u-center AE) is a very powerful PC support tool. It's provided with every *ANTARIS® EvalKit and ANTARIS® Software Customization Kit*. New continuously improved releases can be downloaded for free from our website: <http://www.u-blox.com>.

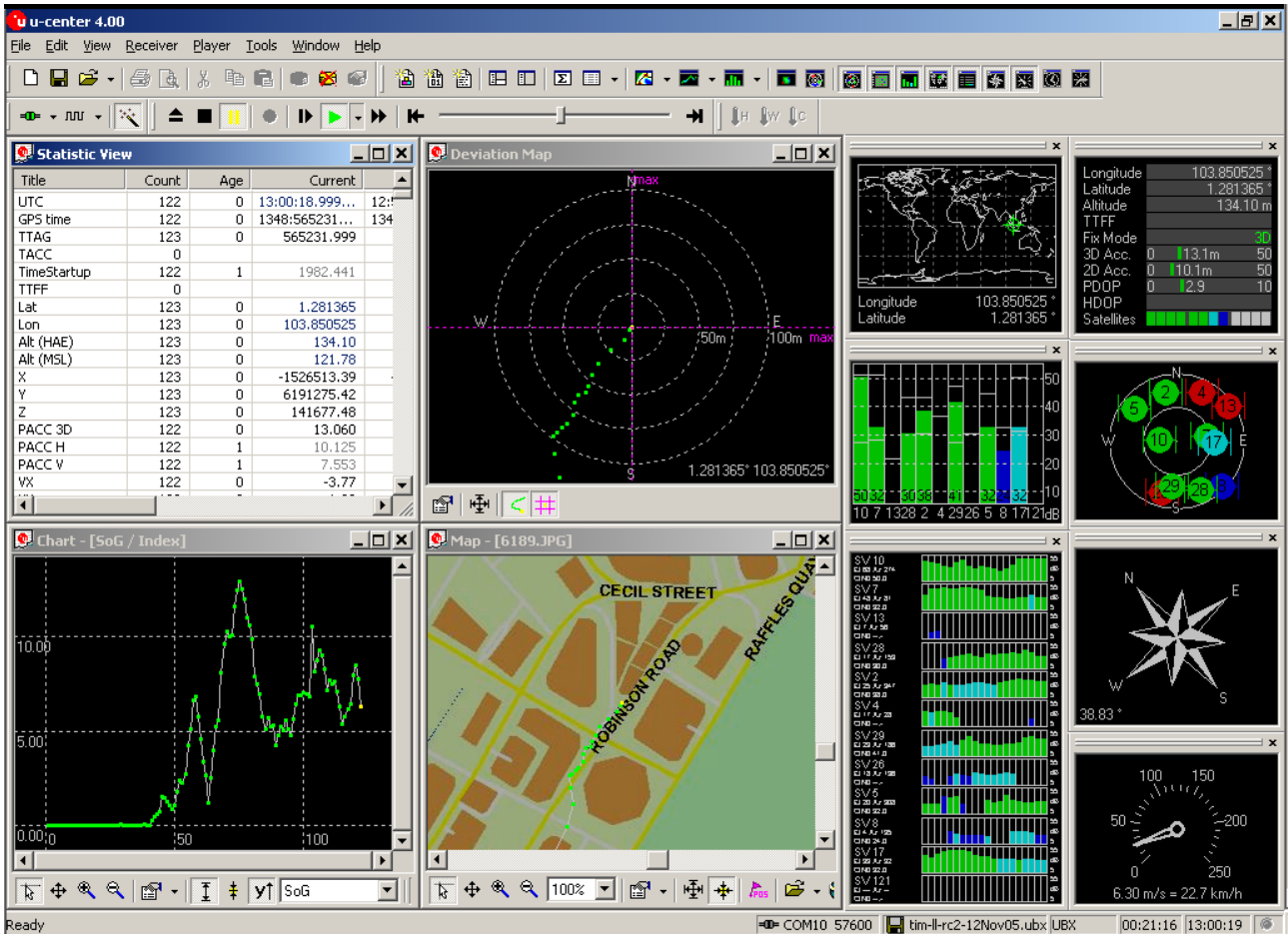

Figure 110: Screenshot, u-center ANTARIS® Edition (u-center AE)

### 7.2.1 Using u-center Message View

The u-center Message View is used to communicate with the GPS receiver. Receiver output messages (e.g. navigation output, status and debug information) are displayed; input messages (e.g. configuration messages) can be sent. There are different sections for NMEA and UBX protocol.

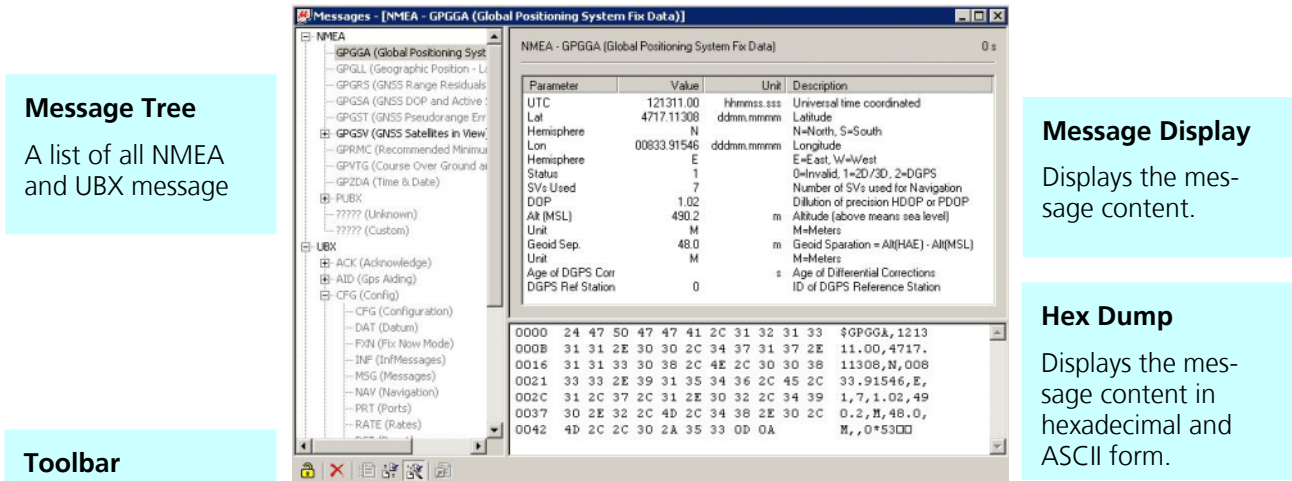

Figure 111: u-Center Message View

Element	Name	Description
	Lock	Prevents the Message View from being updated with new data when locked.
	Clear All	Erases the entire Message View.
	Send	Sends the current message to the GPS receiver.
	Poll	Polls the selected message once.
	Auto poll	Automatically polls a newly selected message once
	Message Hotkey	Assigns a hotkey to the selected message

Table 55: Buttons description in the U-center Message View

### 7.2.1.1 Receiver Output Messages

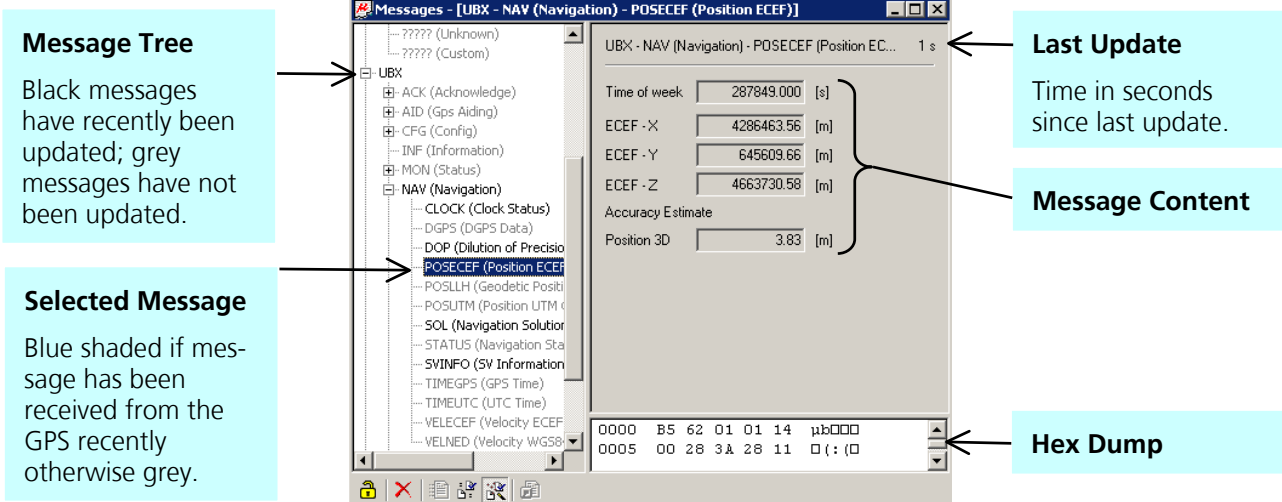

Figure 112: Message Display of a U-center output message

**Note** Double-clicking on an output message enables or disables the periodic message update if the communication protocol is active. This feature is currently only supported for the UBX protocol.

### 7.2.1.2 Receiver Input Messages

Input messages can be edited and sent to the GPS receiver from the Message View. It is also possible to poll the current receiver settings.

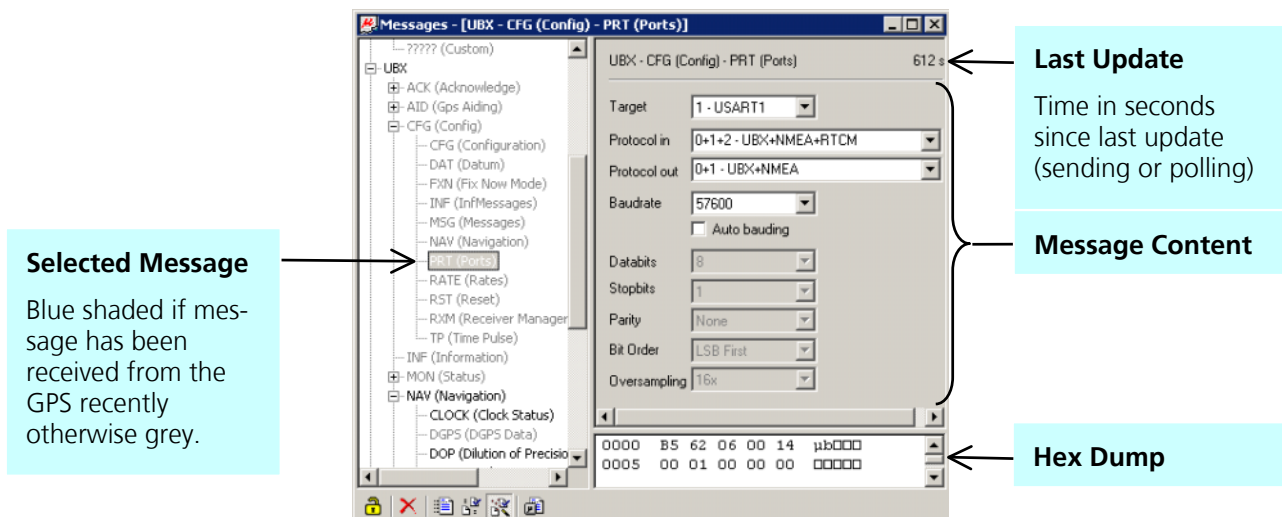

Figure 113: Message Display of a u-center input message

**Note** u-center performs some range checks on input messages. If an input value exceeds the permitted range, u-center will highlight the field in red but it is still possible to send the value to the receiver. However, the receiver is likely to reject such a message.

### 7.2.2 Recording Logfiles

u-center allows recording and playing log file. Using the player controls, one record a log file, step through or play all messages from the log file. The series of buttons in the player toolbar can be used to navigate through the log file. The records will be displayed on the navigation display window, in the same way that live GPS data is displayed when using u-center. Refer to the *u-center AE user's guide [4]* for more information.

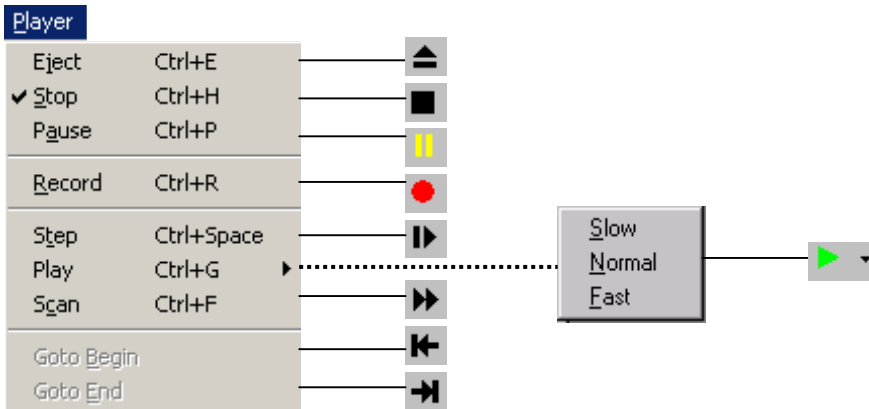

Figure 114: u-center player toolbar

### 7.2.3 Firmware Upgrade with U-center

Please refer to *Section 7.1.2* for further information.

### 7.2.4 Configuration of ANTARIS® 4 based GPS Receivers

u-center AE is able to get the actual configuration of an ANTARIS® based GPS receiver and store it to an ASCII text file containing hexadecimal records. Such a file can be edited and stored to an ANTARIS® based GPS receiver again. By clicking the menu "Tools->GPS Configuration..." of u-center AE, the GPS Configuration dialog opens. The following functions are available:

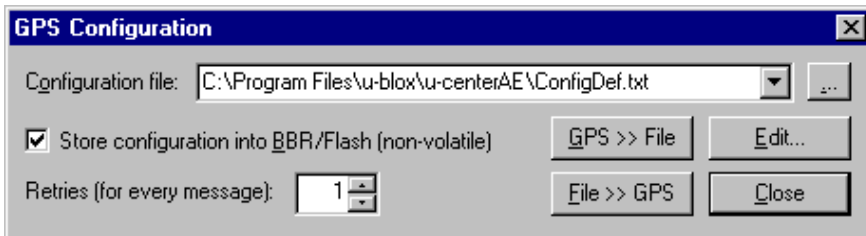

**Figure 115: Screenshot, u-center GPS configuration**

- Specify the name of a new configuration file to store current configuration from the ANTARIS® 4 GPS receiver
- Specify the name of an existing configuration file and load this configuration into the ANTARIS® 4 GPS receiver
- A flag can be set to force storing the configuration into the battery backup RAM (BBR) or Flash EPROM.

If reading or writing configuration data fails too frequently, try to increase the number of retries u-center AE should do on a single message if one fails.

**Note** Sending a configuration to an ANTARIS® 4 GPS receiver may fail due to a baud rate change on the current serial port of the receiver where sending this configuration to. If this happens, simply change the u-center AE's baud rate and send the configuration again.



**Figure 116: Screenshot, u-center getting configuration**

There is a window for showing the progress of data transfer to/from ANTARIS® 4 based GPS receivers. Clicking "GPS >> File" closes the GPS Configuration dialog box and opens the progress window showing configurations being polled and stored into a local file. Clicking "File >> GPS" opens the same progress window showing the configurations that are sent to the ANTARIS® 4 based GPS receiver. This progress window closes after having finished transfer without any error.

The user can abort the transfer by clicking the "Abort" button. It's not possible to close the window unless transfer has completed or the user aborted it.

**Note** It's not recommended to read/write configuration while the ANTARIS® 4 based GPS receiver is in sleep mode.

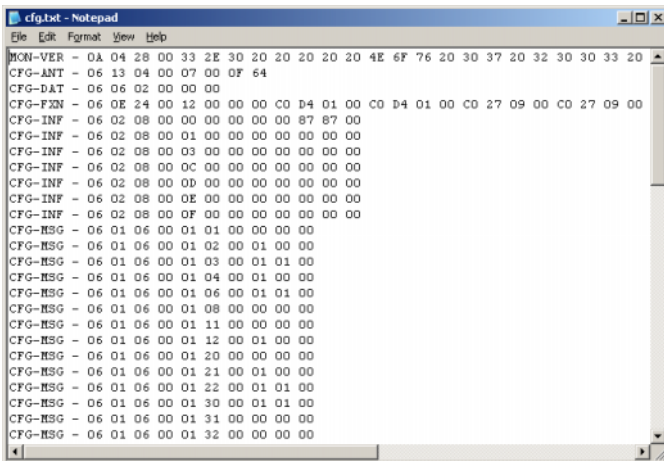

Figure 117: Content of a Configuration File

When clicking the “Edit” button in the GPS Configuration dialog, the Notepad editor opens (standard Windows software). Configurations are stored the following way:

- 1<sup>st</sup> line: it contains the version of the ANTARIS® based GPS receiver where the configuration is from. **Never change this line!**
- For the 2<sup>nd</sup> line and following each line contains the same: <class ID>-<message ID> - <hexadecimal byte code of the message>. The byte code consists of class and message IDs (2 bytes), payload length (2 bytes), payload (payload length bytes). The sync characters and the checksum are not included. They will be calculated automatically.

Please refer to *ANTARIS®4 Protocol Specifications [9]* for detailed information.

## 8 Troubleshooting

### **The ANTARIS® GPS receiver does not meet the TTF specification**

Make sure your antenna has a good sky view. Obstructed view leads to prolonged startup times.

In a well-designed system, the average of the C/No ratio of high elevation satellites should be in the range of 44 dBHz to about 50 dBHz. With a standard off-the-shelf active antenna, 47 dBHz should easily be achieved. Low C/No values lead to a prolonged startup time.

### **The position drifts heavily**

Make sure your antenna has a good sky view. Obstructed view leads to position drift. Check the current satellite constellation before starting static tests in order to make sure it matches the test specifications (typically HDOP<2.0). Check every test drive for critical positions (minimal number of SV in view) and monitor the DOP (e.g. HDOP). If using UBX protocol, don't forget to check the position accuracy estimation.

### **The position is off by a few dozen meters**

The ANTARIS® GPS Technology supports different datums. By default, it starts up with the WGS84 standard GPS datum. If your application expects a different datum, you'll most likely find the positions to be off by a few dozen meters. Find out what kind of datum your application requires and configure the EvalKit accordingly. And do not forget to check the calibration of u-center AE map files.

### **The position is off by hundreds of meters**

Position drift may also occur when almanac navigation is enabled. The satellite orbit information retrieved from an almanac is much less accurate than the information retrieved from the ephemeris. With an almanac only solution the position will only have an accuracy of a few kilometers but it may startup faster or still navigate in areas with obscured visibility when the ephemeris from one or several satellites have not yet been received. The almanac information is NOT used for calculating a position, if valid ephemeris information is present, regardless of the setting of this flag.

In NMEA protocol, position solutions with high deviation (e.g. due to enabling almanac navigation) can be filtered with the Position Accuracy Mask. UBX protocol does not directly support this since it provides a position accuracy estimation, which allows the user to filter the position according to his requirements. However, the 'Position within Limits' flag of the UBX-NAV-STATUS message indicate whether the configured thresholds (i.e. P Accuracy Mask and PDOP) are exceeded.

### **The ANTARIS® GPS does not preserve the configuration in case of a reset**

The ANTARIS® GPS technology uses a slightly different concept than most of the other GPS receivers do. Settings are initially stored to volatile memory. In order to save them permanently, sending a second command is required. This allows testing the new settings and reverting to the old settings by resetting the receiver if the new settings are no good. This is some kind of a safety procedure as it's no longer possible to accidentally program a bad configuration (e.g. disabling the main communication port). See *Section 4.9.2* for the details.

### **On my GPS receiver with external power management, the Hotstart TTF times are much longer than specified**

On startup (after the first position fix) the GPS receiver performs a RTC calibration to have an accurate internal time source. A calibrated RTC is required to achieve minimal startup time.

Before shutting down the receiver externally, check the status in MON-HW in field 'Real Time Clock Status'. Don't shut down the receiver if the RTC is not calibrated.



### **The Battery Backup Current is much higher than specified in the datasheet.**

The battery backup current will be at an undefined level if the backup voltage is applied to the GPS receiver without having the GPS receiver turned on once to put the real-time-clock (RTC) into a known state.

If you are using the GPS receiver with backup battery connected, turn the GPS receiver on for the first time to bring it into a known state (refer to *Section 4.2.2*).

### **Receiver outputs valid time and position but time is off by a few seconds**

The problem is inherent to the GPS system. GPS is based on the so-called **GPS Time**, which is a uniform time scale that does not keep in step with the irregular rotation of the Earth. For practical purposes, another uniform scale has been defined (**UTC**), which differs from GPS Time by an integer number of seconds. To avoid the uniform scale diverging indefinitely from that of the Earth's rotation, a **leap second** is introduced in UTC whenever necessary. The choice of the dates and the announcement of the leap seconds are under the responsibility of the [International Earth Rotation and Reference Systems Service \(IERS\)](#). At the time of writing, the number of leap seconds is 13 but this has changed in the past (see [International Bureau of Weights and Measures](#)) and will change in the future. The GPS satellites transmit the number of leap seconds (the offset between GPS Time and UTC, also called **UTC Offset**) in the navigation message once in 12.5 minutes.

After a cold start, a GPS receiver has no information about the number of leap seconds until this information is received from the GPS satellites, which can take up to 12.5 minutes. During this time, the receiver will have to make an assumption and output a default value. u-blox has decided to output 0s in this case. Some people would prefer 13s (the number of leap seconds at the time being). Though the latter approach seems to be an advantage as one doesn't see any time jump in case of cold starts right now, it is very questionable approach since a potential problem is hidden for a long time. As the number of leap seconds will change sooner or later (the earth rotation slows down), the problem might not occur when the units are already deployed in the field.

What can be done to overcome this problem?

- If one attaches a backup battery to the ANTARIS® GPS receiver and let the receiver run for at least 12.5 minutes when powering it up the first time, the receiver will store the UTC offset in its battery backup RAM (BBR). After the next power cycle, the receiver will use the UTC offset from the BBR and output the number of leap seconds time immediately.
- Alternatively, one could check whether the UTC Offset (leap seconds) has been downloaded by observing the UBX-NAV-TIMEGPS message.
- If this isn't feasible too, one could initialize the UTC offset right after a power up by sending the correct information with the UBX-AID-HUI message. Obviously, this requires an external CPU to store these data.

### **How do ANTARIS®4 Receivers handle changes of leap seconds**

The output of ANTARIS and ANTARIS 4 receivers will be as follows:

```
$GPRMC,235958.00,A,0000.00004,S,00000.00002,E,0.003,0.37,311205,,,A*76
$GPRMC,235959.00,A,0000.00004,S,00000.00002,E,0.001,0.37,311205,,,A*75
$GPRMC,235960.00,A,0000.00005,S,00000.00003,E,0.000,0.37,311205,,,A*7E
$GPRMC,000000.00,A,0000.00005,S,00000.00004,E,0.001,0.37,010106,,,A*71
$GPRMC,000001.00,A,0000.00005,S,00000.00005,E,0.004,0.37,010106,,,A*74
```

### **How to change between protocols**

Refer to *Section 4.4.6*.

### **u-center doesn't behave as expected**

Please refer to the *u-center user's guide* for more information.

### **My application (e.g. u-center AE) does not receive anything**

Check if the evaluation box is powered and make sure the serial cable is properly connected to the evaluation box and the PC. By default, the evaluation box will output UBX protocol on port 1 at 57600 baud.

### **My application (e.g. u-center AE) does not receive all messages**

Make sure the baud rate is sufficient. If the baud rate is insufficient, GPS receivers based on the ANTARIS® GPS Technology will skip excessive messages.

Some serial port cards/adapters (i.e. USB to RS232 converter) frequently generate errors. If a communication error occurs while u-center receives a message, the message will be discarded.

### **My application (e.g. u-center AE) loses the connection to the GPS receiver**

The ANTARIS® GPS Technology and u-center have an autobauding feature. If frequent communication errors occur (i.e. due to problems with the serial port), the connection may be lost since u-center AE and the GPS receiver will autonomously try to adjust the baud rate. Do not enable the u-center AE autobauding feature if the GPS receiver has the autobauding flag enabled.

### **Some COM ports are not shown in the port list of my application (e.g. u-center AE)**

Only the COM ports, that are available on your computer, will show up in the COM port drop down list. If a COM Port is gray, another application running on this computer is using it.

### **The GPS receiver EvalKit doesn't behave as expected**

Please refer to the *ANTARIS® EvalKit - Users Guide* for more information.

# A Default Settings

**Note** For the default settings for the ROM-only - Low Cost GPS receivers please refer as well to *Section 4.8.2* as the configuration settings are defined by the status of the GPSPIN Pins at the start up.

## A.1 Hardware

### Antenna Configuration (UBX – CFG – ANT)

#### Programmable GPS Receivers (LEA-4H, LEA-4P, TIM-4H and TIM-4P)

Parameter	Default setting	Unit	Range/Remark
Enable Control Signal	Enabled		Enabled - Disabled
Enable Short Circuit Detection	Enabled		Enabled - Disabled
Enable Short Circuit Power Down logic	Enabled		Enabled - Disabled
Enable Automatic Short Circuit Recovery	Disabled		Enabled - Disabled
Enable Open circuit detection	Disabled		Enabled - Disabled

Table 56: Antenna settings

#### Low Cost (ROM only) GPS Receivers (LEA-4A, LEA-4S, LEA-4M<sup>19</sup>, TIM-4A, TIM-4S and NEO-4S)

Parameter	Default setting	Unit	Range/Remark
Enable Control Signal	Enabled		Enabled - Disabled
Enable Short Circuit Detection	Enabled		Enabled - Disabled
Enable Short Circuit Power Down logic	Enabled		Enabled - Disabled
Enable Automatic Short Circuit Recovery	Disabled		Enabled - Disabled
Enable Open circuit detection	Enabled		Enabled - Disabled

Table 57: Antenna settings

## A.2 Navigation

### Datum (UBX – CFG – DAT)

Parameter	Default setting	Unit	Range/Remark
Datum	0 – WGS84		Refer to <i>Appendix B</i>

Table 58: Datum default settings

<sup>19</sup> Please refer to section 4.3.3.2 for more information about NEO-4S and LEA-4M

**Navigation (UBX – CFG – NAV2)**

Parameter	Default setting	Unit	Range/Remark
<b>Dynamic Platform Model</b>	3-Automotive		1-Stationary; 2- Pedestrian; 3-Automotive; 4-Sea; 5-Airborne <1g; 6-Airborne <2g; 7-Airborne <4g
<b>Allow Almanac Navigation</b>	Disabled		Enabled - Disabled
<b>Static Hold Threshold</b>	0.00	m/s	
<b>Navigation Input Filters</b>			
Initial Min SV	3	#	3..16
Min SV's	3	#	3..16
Max SV's	16	#	3..16
Initial Min C/NO (Fix)	15/ 24	dBHz	Supersense®/ Standard GPS
Min C/NO	10/ 20	dBHz	Supersense®/ Standard GPS
Min SV Elevation	5	deg	
DR Timeout	0	s	
<b>Navigation Output Filters</b>			
PDOP Mask	25	-	
TDOP Mask	25	-	
P Accuracy	100	m	
T Accuracy	300	m	
<b>Fix Mode</b>	Auto 2D/3D	#	Auto 2D/3D – 2D only – 3D only
<b>RAIM</b>	Enabled		Enabled - Disabled; DO NOT DISABLE!
<b>DGPS Timeout</b>	60	s	
<b>Fixed Altitude</b>	500	m	

**Table 59: Navigation default settings**
**NMEA Protocol (UBX – CFG – NMEA)**

Parameter	Default setting	Unit	Range/Remark
<b>Enable position output even for invalid fixes</b>	Disabled		Enabled - Disabled
<b>Enable position even for masked fixes</b>	Disabled		Enabled - Disabled
<b>Enable time output even for invalid times</b>	Disabled		Enabled - Disabled
<b>Enable time output even for invalid dates</b>	Disabled		Enabled - Disabled
<b>Version</b>	2.3		
<b>Compatibility Mode</b>	Enabled		Enabled – Disabled (Compatible to TOM-TOM, NOKIA etc)

**Table 60: NMEA Protocol default settings**
**Output Rates (UBX – CFG – RATE)**

Parameter	Default setting	Unit	Range/Remark
<b>Time Source</b>	0 – UTC		0 – UTC1 - GPS
<b>Measurement Period</b>	1000	ms	
<b>Measurement Rate</b>	1	Cycles	

**Table 61: Output Rates default settings**

## Receiver Manager (UBX - CFG – RXM)

### LEA-4A, LEA-4P, LEA-4M, TIM-4A, TIM-4P and TIM-4R

Parameter	Default setting	Unit	Range/Remark
GPS Mode	Normal		Auto; Normal; Fast Acquisition; High Sensitivity
Low Power Mode	0 – CTM		0 - CTM; 1 - FXN

Table 62: Receiver Configuration default settings of LEA-4A, LEA-4P, LEA-4M, TIM-4A and TIM-4P

### LEA-4H, TIM-4H and NEO-4S

Parameter	Default setting	Unit	Range/Remark
GPS Mode	Auto		Auto; Normal; Fast Acquisition; High Sensitivity
Low Power Mode	0 – CTM		0 - CTM; 1 - FXN

Table 63: Receiver Configuration default settings of LEA-4H, TIM-4H and NEO-4S

### LEA-4S and TIM-4S

Parameter	Default setting	Unit	Range/Remark
GPS Mode	High Sensitivity		Auto; Normal; Fast Acquisition; High Sensitivity
Low Power Mode	0 – CTM		0 - CTM; 1 - FXN

Table 64: Receiver Configuration default settings of LEA-4S and TIM-4S

## A.3 Power Saving Modes

### FixNOW™ Mode (UBX - CFG – FXN)

Parameter	Default setting	Unit	Range/Remark
<b>On/ off time – Timeout</b>			
Use on/off time	Enabled		Enabled - Disabled
T_on	36	s	
T_off	1800	s	
Absolute align	Disabled		Enabled - Disabled
Base TOW	0	s	
<b>Startup – Timeout</b>			
T_acq	120	s	
T_acq_off	600	s	
<b>Last Fix – Timeout</b>			
T_reacq	120	s	
T_reacq_off	600	s	
<b>System Mode</b>	Sleep		On; Sleep; Backup

Table 65: FixNOW™ default settings

## A.4 SBAS Configuration

### SBAS Configuration

Parameter	Default setting	Unit	Range/Remark
<b>SBAS Subsystem</b>	Enabled		Enabled – Disabled
Allow test mode usage	Disabled		Enabled – Disabled
<b>Services</b>			
Ranging (Use SBAS for navigation)	Enabled		Enabled – Disabled
Apply SBAS Correction Data	Disabled		Enabled – Disabled
Apply integrity information	Disabled		Enabled – Disabled
<b>Number of search channels</b>	1		1..3
<b>PRN Codes</b>	Auto-Scan		Auto-Scan; WAAS; EGNOS; Other

Table 66: SBAS Configuration default settings

## A.5 Communications Interface

A4

### Port Setting (UBX – CFG – PRT)

Parameter	Default setting	Unit	Range/Remark
<b>USART1 (TARGET1)</b>			
Protocol in	0+1+2 – UBX+NMEA+RTCM		None; 0 – UBX; 1 – NMEA; 2 – RTCM; 12 – USER0; 13 – USER1; 14 – USER2 ; 15 – USER3
Protocol out	0+1 – NMEA + UBX		None; 0 – UBX; 1 – NMEA; 2 – RTCM; 12 – USER0; 13 – USER1; 14 – USER2 ; 15 – USER3
Baudrate	9600	baud	8 bits, no parity bit 1 stop bit
Autobauding	Disabled		Enabled - Disabled
<b>USART2 (TARGET2)</b>			
Protocol in	0+1+2 – UBX+NMEA+RTCM		None; 0 – UBX; 1 – NMEA; 2 – RTCM; 12 – USER0; 13 – USER1; 14 – USER2 ; 15 – USER3
Protocol out	0+1 – UBX+NMEA		None; 0 – UBX; 1 – NMEA; 2 – RTCM; 12 – USER0; 13 – USER1; 14 – USER2 ; 15 – USER3
Baudrate	57600 / 38400 <sup>20</sup>	baud	8 bits, no parity bit 1 stop bit
Autobauding	Disabled		Enabled – Disabled
<b>USB (TARGET3) (LEA only)</b>			
Protocol in	0+1 – UBX+NMEA		None; 0 – UBX; 1 – NMEA; 2 – RTCM; 12 – USER0; 13 – USER1; 14 – USER2 ; 15 – USER3
Protocol out	0+1 – UBX+NMEA		None; 0 – UBX; 1 – NMEA; 2 – RTCM; 12 – USER0; 13 – USER1; 14 – USER2 ; 15 – USER3

Table 67: Port default settings

### Port Setting (UBX – CFG – USB) (LEA and NEO only)

A4

Parameter	Default setting	Unit	Range/Remark
<b>Power Mode</b>			
Power Mode	Self powered		Self powered – Bus powered
Bus Current required	100	MA	

Table 68: USB default settings

<sup>20</sup> 57600 Baud: LEA-4P, LEA-4H, LEA-4t, TIM-4P, TIM-4H  
38400 Baud: LEA-4S, LEA-4A, TIM-4A, TIM-4S

## A.6 Messages (UBX – CFG – MSG)

UBX

Message	Type	USART1 (TARGET1 <sup>21</sup> )	USART2 (TARGET2)	USB (TARGET3)	Range/Remark
NAV-POSECEF	Out				
NAV-POSLLH	Out		1		
NAV-STATUS	Out		1		
NAV-DOP	Out				
NAV-SOL	Out		1		
NAV-POSUTM	Out				
NAV-VELECEF	Out				
NAV-VELNED	Out				
NAV-TIMEGPS	Out				
NAV-TIMEUTC	Out				
NAV-CLOCK	Out				
NAV-SVINFO	Out		1		
NAV-DGPS	Out				
NAV-SBAS	Out				
NAV-EKFSTATUS	Out				
RXM-RAW	Out				
RXM-SFRB	Out				
RXM-SVSI	Out				
RXM-RTC	Out				
RXM-ALM	Out				
RXM-EPH	Out				
MON-SCHD	Out		1		
MON-IO	Out		1		
MON-IPC	Out				
MON-MSGPP	Out				
MON-RXBUF	Out				
MON-TXBUF	Out		1		
MON-HW	Out				
MON-EXCEPT	Out		1		
MON-VER	Out				
AID-ALM	In/Out				
AID-EPH	In/Out				
AID-HUI	In/Out				
AID-INI	In/Out				
TIM-TP	Out				
TIM-TM	Out				

**Table 69: UBX output rate default settings**

<sup>21</sup> The Number entered under Target1 – Target2 defines the output cycle: 1 means every measurement cycle, 2 every 2<sup>nd</sup> measurement etc.

## NMEA

Message	Type	USART1 (TARGET1 <sup>22</sup> )	USART2 (TARGET2)	USB (TARGET3)	Range/Remark
NMEA - DTM	Out				
NMEA - GBS	Out				
NMEA - GGA	Out	1		1	
NMEA - GLL	Out	1		1	
NMEA - GSA	Out	1		1	
NMEA - GSV	Out	1		1	
NMEA - RMC	Out	1		1	
NMEA - VTG	Out	1		1	
NMEA - GRS	Out				
NMEA - GST	Out				
NMEA - ZDA	Out	1		1	
NMEA – PUBX,00	Out				
NMEA – PUBX,01	Out				
NMEA – PUBX,03	Out				
NMEA – PUBX,04	Out				

**Table 70: NMEA enabled output msg**

## A.7 Messages (UBX – CFG – INF)

A4

### UBX

Message	Type	USART1 (TARGET1 <sup>23</sup> )	USART2 (TARGET2)	USB (TARGET3 <sup>23</sup> )	Range/Remark
INF-Error	Out	1			
INF-Warning	Out	1			
INF-Notice	Out	1			
INF-Test	Out				
INF-Debug	Out				
INF-User	Out	1			

**Table 71: UBX default enabled INF msg**

### NMEA

Message	Type	USART1 (TARGET1 <sup>24</sup> )	USART2 (TARGET2)	USB (TARGET3)	Range/Remark
INF-Error	Out	1		1	
INF-Warning	Out	1		1	
INF-Notice	Out	1		1	
INF-Test	Out				
INF-Debug	Out				
INF-User	Out	1		1	

**Table 72: NMEA default enabled INF msg**

<sup>22</sup> The Number entered under Target1 – Target2 defines the output cycle: 1 means every measurement cycle, 2 every 2<sup>nd</sup> measurement etc.

<sup>23</sup> The Number entered under Target1 – Target2 defines the output cycle: 1 means every measurement cycle, 2 every 2<sup>nd</sup> measurement etc.

<sup>24</sup> The Number entered under Target1 – Target2 defines the output cycle: 1 means every measurement cycle, 2 every 2<sup>nd</sup> measurement etc.



## A.8 Timing Settings

### Timemark (UBX – CFG – TM2)

Parameter	Default setting	unit	Range/Remark
Input Line	31 – EXTINT0		0 – EXTINT 0; 1 – EXTINT 1; 2 – EXTINT 2
Enable Timemark	Disabled		Enabled; disabled
Mode	Run		Run; Single
Time Base	UTC		UTC; GPS
Trigger Edge	Rising		Rising; Falling
Poll Rate	1000	ms	

**Table 73: Timemark default settings**

### Timepulse (UBX – CFG – TP)

Parameter	Default setting	unit	Range/Remark
Pulse Mode	+1 - rising		+1 – rising; 0 – disabled; -1 - falling
Pulse Period	1000	ms	1 ... 60'000
Pulse Length	100	ms	1us ... (Pulse Period – 0.250 us)
Time Source	1 – GPS time		0 – UTC time; 1 – GPS time
Cable Delay	50	ns	$\pm 2 \times 10^9$ us
User Delay	0	ns	$\pm 2 \times 10^9$ us

**Table 74: Timepulse default settings**

## B Map Datums

### B.1 Predefined Datums

Please refer to the booklet *GPS Basics, Introduction to the system [2]* for a detailed introduction to coordinate systems, datums and datum conversion.

Index	Name	Acronym	Ellipsoid index (see Table 76)	Rotation and scale index (see Table 77)	dX [m]	dY [m]	dZ [m]
0	World Geodetic System - 84	WGS84	0	0	0.0	0.0	0.0
1	World Geodetic System - 72	WGS72	23	1	0.0	0.0	4.5
2	Earth-90 - GLONASS Coordinate system	ETH90	8	0	0.0	0.0	4.0
3	Adindan - Mean Solution (Ethiopia & Sudan)	ADI-M	7	0	-166.0	-15.0	204.0
4	Adindan - Burkina Faso	ADI-E	7	0	-118.0	-14.0	218.0
5	Adindan - Cameroon	ADI-F	7	0	-134.0	-2.0	210.0
6	Adindan - Ethiopia	ADI-A	7	0	-165.0	-11.0	206.0
7	Adindan - Mali	ADI-C	7	0	-123.0	-20.0	220.0
8	Adindan - Senegal	ADI-D	7	0	-128.0	-18.0	224.0
9	Adindan - Sudan	ADI-B	7	0	-161.0	-14.0	205.0
10	Afgooye - Somalia	AFG	21	0	-43.0	-163.0	45.0
11	ARC 1950 - Mean (Botswana, Lesotho, Malawi, Swaziland, Zaire, Zambia, Zimbabwe)	ARF-M	7	0	-143.0	-90.0	-294.0
12	ARC 1950 - Botswana	ARF-A	7	0	-138.0	-105.0	-289.0
13	ARC 1950 - Burundi	ARF-H	7	0	-153.0	-5.0	-292.0
14	ARC 1950 - Lesotho	ARF-B	7	0	-125.0	-108.0	-295.0
15	ARC 1950 - Malawi	ARF-C	7	0	-161.0	-73.0	-317.0
16	ARC 1950 - Swaziland	ARF-D	7	0	-134.0	-105.0	-295.0
17	ARC 1950 - Zaire	ARF-E	7	0	-169.0	-19.0	-278.0
18	ARC 1950 - Zambia	ARF-F	7	0	-147.0	-74.0	-283.0
19	ARC 1950 - Zimbabwe	ARF-G	7	0	-142.0	-96.0	-293.0
20	ARC 1960 - Mean (Kenya, Tanzania)	ARS	7	0	-160.0	-6.0	-302.0
21	Ayabelle Lighthouse - Djibouti	PHA	7	0	-79.0	-129.0	145.0
22	Bissau - Guinea-Bissau	BID	20	0	-173.0	253.0	27.0
23	Cape - South Africa	CAP	7	0	-136.0	-108.0	-292.0
24	Carthage - Tunisia	CGE	7	0	-263.0	6.0	431.0
25	Dabola - Guinea	DAL	7	0	-83.0	37.0	124.0
26	Leigon - Ghana	LEH	7	0	-130.0	29.0	364.0
27	Liberia 1964	LIB	7	0	-90.0	40.0	88.0
28	Massawa - Eritrea (Ethiopia)	MAS	5	0	639.0	405.0	60.0
29	Merchich - Morocco	MER	7	0	31.0	146.0	47.0
30	Minna - Cameroon	MIN-A	7	0	-81.0	-84.0	115.0
31	Minna - Nigeria	MIN-B	7	0	-92.0	-93.0	122.0
32	M'Poraloko - Gabon	MPO	7	0	-74.0	-130.0	42.0

Index	Name	Acronym	Ellipsoid index (see Table 76)	Rotation and scale index (see Table 77)	dX [m]	dY [m]	dZ [m]
33	North Sahara 1959 - Algeria	NSD	7	0	-186.0	-93.0	310.0
34	Old Egyptian 1907 - Egypt	OEG	17	0	-130.0	110.0	-13.0
35	Point 58 - Mean Solution (Burkina Faso & Niger)	PTB	7	0	-106.0	-129.0	165.0
36	Pointe Noire 1948 - Congo	PTN	7	0	-148.0	51.0	-291.0
37	Schwarzeck - Namibia	SCK	5	0	616.0	97.0	-251.0
38	Voirol 1960 - Algeria	VOR	7	0	-123.0	-206.0	219.0
39	Ain El Abd 1970 - Bahrain Island	AIN-A	20	0	-150.0	-250.0	-1.0
40	Ain El Abd 1970 - Saudi Arabia	AIN-B	20	0	-143.0	-236.0	7.0
41	Djakarta (Batavia)- Sumatra (Indonesia)	BAT	5	0	-377.0	681.0	-50.0
42	Hong Kong 1963 - Hong Kong	HKD	20	0	-156.0	-271.0	-189.0
43	Hu-Tzu-Shan - Taiwan	HTN	20	0	-637.0	-549.0	-203.0
44	Indian - Bangladesh	IND-B	9	0	282.0	726.0	254.0
45	Indian - India & Nepal	IND-I	11	0	295.0	736.0	257.0
46	Indian 1954 - Thailand	INF-A	9	0	217.0	823.0	299.0
47	Indian 1960 - Vietnam (near 16N)	ING-A	9	0	198.0	881.0	317.0
48	Indian 1960 - Con Son Island (Vietnam)	ING-B	9	0	182.0	915.0	344.0
49	Indian 1975 - Thailand	INH-A	9	0	209.0	818.0	290.0
50	Indonesian 1974	IDN	19	0	-24.0	-15.0	5.0
51	Kandawala - Sri Lanka	KAN	9	0	-97.0	787.0	86.0
52	Kertau 1948 - West Malaysia & Singapore	KEA	13	0	-11.0	851.0	5.0
53	Nahrwan - Masirah Island (Oman)	NAH-A	7	0	-247.0	-148.0	369.0
54	Nahrwan - United Arab Emirates	NAH-B	7	0	-249.0	-156.0	381.0
55	Nahrwan - Saudi Arabia	NAH-C	7	0	-243.0	-192.0	477.0
56	Oman	FAH	7	0	-346.0	-1.0	224.0
57	Qatar National - Qatar	QAT	20	0	-128.0	-283.0	22.0
58	South Asia - Singapore	SOA	15	0	7.0	-10.0	-26.0
59	Timbalai 1948 - Brunei & East Malaysia (Sarawak & Sabah)	TIL	10	0	-679.0	669.0	-48.0
60	Tokyo - Mean Solution (Japan, Okinawa & South Korea)	TOY-M	5	0	-148.0	507.0	685.0
61	Tokyo - Japan	TOY-A	5	0	-148.0	507.0	685.0
62	Tokyo - Okinawa	TOY-C	5	0	-158.0	507.0	676.0
63	Tokyo - South Korea	TOY-B	5	0	-146.0	507.0	687.0
64	Australian Geodetic 1966 - Australia & Tasmania	AUA	3	0	-133.0	-48.0	148.0
65	Australian Geodetic 1984 - Australia & Tasmania	AUG	3	0	-134.0	-48.0	149.0
66	European 1950 - Mean (AU, B, DK, FN, F, G, GER, I, LUX, NL, N, P, E, S, CH)	EUR-M	20	0	-87.0	-98.0	-121.0
67	European 1950 - Western Europe (AU, DK, FR, GER, NL, CH)	EUR-A	20	0	-87.0	-96.0	-120.0
68	European 1950 - Cyprus	EUR-E	20	0	-104.0	-101.0	-140.0
69	European 1950 - Egypt	EUR-F	20	0	-130.0	-117.0	-151.0

Index	Name	Acronym	Ellipsoid index (see Table 76)	Rotation and scale index (see Table 77)	dX [m]	dY [m]	dZ [m]
70	European 1950 - England, Wales, Scotland & Channel Islands	EUR-G	20	0	-86.0	-96.0	-120.0
71	European 1950 - England, Wales, Scotland & Ireland	EUR-K	20	0	-86.0	-96.0	-120.0
72	European 1950 - Greece	EUR-B	20	0	-84.0	-95.0	-130.0
73	European 1950 - Iran	EUR-H	20	0	-117.0	-132.0	-164.0
74	European 1950 - Italy - Sardinia	EUR-I	20	0	-97.0	-103.0	-120.0
75	European 1950 - Italy - Sicily	EUR-J	20	0	-97.0	-88.0	-135.0
76	European 1950 - Malta	EUR-L	20	0	-107.0	-88.0	-149.0
77	European 1950 - Norway & Finland	EUR-C	20	0	-87.0	-95.0	-120.0
78	European 1950 - Portugal & Spain	EUR-D	20	0	-84.0	-107.0	-120.0
79	European 1950 - Tunisia	EUR-T	20	0	-112.0	-77.0	-145.0
80	European 1979 - Mean Solution (AU, FN, NL, N, E, S, CH)	EUS	20	0	-86.0	-98.0	-119.0
81	Hjorsey 1955 - Iceland	HJO	20	0	-73.0	46.0	-86.0
82	Ireland 1965	IRL	2	0	506.0	-122.0	611.0
83	Ordnance Survey of GB 1936 - Mean (E, IoM, S, ShI, W)	OGB-M	1	0	375.0	-111.0	431.0
84	Ordnance Survey of GB 1936 - England	OGB-A	1	0	371.0	-112.0	434.0
85	Ordnance Survey of GB 1936 - England, Isle of Man & Wales	OGB-B	1	0	371.0	-111.0	434.0
86	Ordnance Survey of GB 1936 - Scotland & Shetland Isles	OGB-C	1	0	384.0	-111.0	425.0
87	Ordnance Survey of GB 1936 - Wales	OGB-D	1	0	370.0	-108.0	434.0
88	Rome 1940 - Sardinia Island	MOD	20	0	-225.0	-65.0	9.0
89	S-42 (Pulkovo 1942) - Hungary	SPK	21	0	28.0	-121.0	-77.0
90	S-JTSK Czechoslovakia (prior to 1 Jan 1993)	CCD	5	0	589.0	76.0	480.0
91	Cape Canaveral - Mean Solution (Florida & Bahamas)	CAC	6	0	-2.0	151.0	181.0
92	N. American 1927 - Mean Solution (CONUS)	NAS-C	6	0	-8.0	160.0	176.0
93	N. American 1927 - Western US	NAS-B	6	0	-8.0	159.0	175.0
94	N. American 1927 - Eastern US	NAS-A	6	0	-9.0	161.0	179.0
95	N. American 1927 - Alaska (excluding Aleutian Islands)	NAS-D	6	0	-5.0	135.0	172.0
96	N. American 1927 - Aleutian Islands, East of 180W	NAS-V	6	0	-2.0	152.0	149.0
97	N. American 1927 - Aleutian Islands, West of 180W	NAS-W	6	0	2.0	204.0	105.0
98	N. American 1927 - Bahamas (excluding San Salvador Island)	NAS-Q	6	0	-4.0	154.0	178.0
99	N. American 1927 - San Salvador Island	NAS-R	6	0	1.0	140.0	165.0
100	N. American 1927 - Canada Mean Solution (including Newfoundland)	NAS-E	6	0	-10.0	158.0	187.0
101	N. American 1927 - Alberta & British Columbia	NAS-F	6	0	-7.0	162.0	188.0

Index	Name	Acronym	Ellipsoid index (see Table 76)	Rotation and scale index (see Table 77)	dX [m]	dY [m]	dZ [m]
102	N. American 1927 - Eastern Canada (Newfoundland, New Brunswick, Nova Scotia & Quebec)	NAS-G	6	0	-22.0	160.0	190.0
103	N. American 1927 - Manitoba & Ontario	NAS-H	6	0	-9.0	157.0	184.0
104	N. American 1927 - Northwest Territories & Saskatchewan	NAS-I	6	0	4.0	159.0	188.0
105	N. American 1927 - Yukon	NAS-J	6	0	-7.0	139.0	181.0
106	N. American 1927 - Canal Zone	NAS-O	6	0	0.0	125.0	201.0
107	N. American 1927 - Caribbean	NAS-P	6	0	-3.0	142.0	183.0
108	N. American 1927 - Central America	NAS-N	6	0	0.0	125.0	194.0
109	N. American 1927 - Cuba	NAS-T	6	0	-9.0	152.0	178.0
110	N. American 1927 - Greenland (Hayes Peninsula)	NAS-U	6	0	11.0	114.0	195.0
111	N. American 1927 - Mexico	NAS-L	6	0	-12.0	130.0	190.0
112	N. American 1983 - Alaska (excluding Aleutian Islands)	NAR-A	16	0	0.0	0.0	0.0
113	N. American 1983 - Aleutian Islands	NAR-E	16	0	-2.0	0.0	4.0
114	N. American 1983 - Canada	NAR-B	16	0	0.0	0.0	0.0
115	N. American 1983 - Mean Solution (CONUS)	NAR-C	16	0	0.0	0.0	0.0
116	N. American 1983 - Hawaii	NAR-H	16	0	1.0	1.0	-1.0
117	N. American 1983 - Mexico & Central America	NAR-D	16	0	0.0	0.0	0.0
118	Bogota Observatory - Colombia	BOO	20	0	307.0	304.0	-318.0
119	Campo Inchauspe 1969 - Argentina	CAI	20	0	-148.0	136.0	90.0
120	Chua Astro - Paraguay	CHU	20	0	-134.0	229.0	-29.0
121	Corrego Alegre - Brazil	COA	20	0	-206.0	172.0	-6.0
122	Prov S. American 1956 - Mean Solution (Bol, Col, Ecu, Guy, Per & Ven)	PRP-M	20	0	-288.0	175.0	-376.0
123	Prov S. American 1956 - Bolivia	PRP-A	20	0	-270.0	188.0	-388.0
124	Prov S. American 1956 - Northern Chile (near 19S)	PRP-B	20	0	-270.0	183.0	-390.0
125	Prov S. American 1956 - Southern Chile (near 43S)	PRP-C	20	0	-305.0	243.0	-442.0
126	Prov S. American 1956 - Colombia	PRP-D	20	0	-282.0	169.0	-371.0
127	Prov S. American 1956 - Ecuador	PRP-E	20	0	-278.0	171.0	-367.0
128	Prov S. American 1956 - Guyana	PRP-F	20	0	-298.0	159.0	-369.0
129	Prov S. American 1956 - Peru	PRP-G	20	0	-279.0	175.0	-379.0
130	Prov S. American 1956 - Venezuela	PRP-H	20	0	-295.0	173.0	-371.0
131	Prov South Chilean 1963	HIT	20	0	16.0	196.0	93.0
132	South American 1969 - Mean Solution (Arg, Bol, Bra, Chi, Col, Ecu, Guy, Par, Per, Tri & Tob, Ven)	SAN-M	22	0	-57.0	1.0	-41.0
133	South American 1969 - Argentina	SAN-A	22	0	-62.0	-1.0	-37.0
134	South American 1969 - Bolivia	SAN-B	22	0	-61.0	2.0	-48.0
135	South American 1969 - Brazil	SAN-C	22	0	-60.0	-2.0	-41.0

Index	Name	Acronym	Ellipsoid index (see Table 76)	Rotation and scale index (see Table 77)	dX [m]	dY [m]	dZ [m]
136	South American 1969 - Chile	SAN-D	22	0	-75.0	-1.0	-44.0
137	South American 1969 - Colombia	SAN-E	22	0	-44.0	6.0	-36.0
138	South American 1969 - Ecuador (excluding Galapagos Islands)	SAN-F	22	0	-48.0	3.0	-44.0
139	South American 1969 - Baltra, Galapagos Islands	SAN-J	22	0	-47.0	26.0	-42.0
140	South American 1969 - Guyana	SAN-G	22	0	-53.0	3.0	-47.0
141	South American 1969 - Paraguay	SAN-H	22	0	-61.0	2.0	-33.0
142	South American 1969 - Peru	SAN-I	22	0	-58.0	0.0	-44.0
143	South American 1969 - Trinidad & Tobago	SAN-K	22	0	-45.0	12.0	-33.0
144	South American 1969 - Venezuela	SAN-L	22	0	-45.0	8.0	-33.0
145	Zanderij - Suriname	ZAN	20	0	-265.0	120.0	-358.0
146	Antigua Island Astro 1943 - Antigua, Leeward Islands	AIA	7	0	-270.0	13.0	62.0
147	Ascension Island 1958	ASC	20	0	-205.0	107.0	53.0
148	Astro Dos 71/4 - St Helena Island	SHB	20	0	-320.0	550.0	-494.0
149	Bermuda 1957 - Bermuda Islands	BER	6	0	-73.0	213.0	296.0
150	Deception Island, Antarctica	DID	7	0	260.0	12.0	-147.0
151	Fort Thomas 1955 - Nevis, St Kitts, Leeward Islands	FOT	7	0	-7.0	215.0	225.0
152	Graciosa Base SW 1948 - Faial, Graciosa, Pico, Sao Jorge, Terceira Islands (Azores)	GRA	20	0	-104.0	167.0	-38.0
153	ISTS 061 Astro 1968 - South Georgia Islands	ISG	20	0	-794.0	119.0	-298.0
154	L.C. 5 Astro 1961 - Cayman Brac Island	LCF	6	0	42.0	124.0	147.0
155	Montserrat Island Astro 1958 - Montserrat Leeward Islands	ASM	7	0	174.0	359.0	365.0
156	Naparima, BWI - Trinidad & Tobago	NAP	20	0	-10.0	375.0	165.0
157	Observatorio Meteorologico 1939 - Corvo and Flores Islands (Azores)	FLO	20	0	-425.0	-169.0	81.0
158	Pico De Las Nieves - Canary Islands	PLN	20	0	-307.0	-92.0	127.0
159	Porto Santo 1936 - Porto Santo and Madeira Islands	POS	20	0	-499.0	-249.0	314.0
160	Puerto Rico - Puerto Rico & Virgin Islands	PUR	6	0	11.0	72.0	-101.0
161	Qornoq - South Greenland	QUO	20	0	164.0	138.0	-189.0
162	Sao Braz - Soa Miguel, Santa Maria Islands (Azores)	SAO	20	0	-203.0	141.0	53.0
163	Sapper Hill 1943 - East Falkland Island	SAP	20	0	-355.0	21.0	72.0
164	Selvagem Grande 1938 - Salvage Islands	SGM	20	0	-289.0	-124.0	60.0
165	Tristan Astro 1968 - Tristan du Cunha	TDC	20	0	-632.0	438.0	-609.0
166	Anna 1 Astro 1965 - Cocos Islands	ANO	3	0	-491.0	-22.0	435.0
167	Gandajika Base 1970 - Republic of Maldives	GAA	20	0	-133.0	-321.0	50.0
168	ISTS 073 Astro 1969 - Diego Garcia	IST	20	0	208.0	-435.0	-229.0
169	Kerguelen Island 1949 - Kerguelen Island	KEG	20	0	145.0	-187.0	103.0

Index	Name	Acronym	Ellipsoid index (see Table 76)	Rotation and scale index (see Table 77)	dX [m]	dY [m]	dZ [m]
170	Mahe 1971 - Mahe Island	MIK	7	0	41.0	-220.0	-134.0
171	Reunion - Mascarene Islands	RUE	20	0	94.0	-948.0	-1262.0
172	American Samoa 1962 - American Samoa Islands	AMA	6	0	-115.0	118.0	426.0
173	Astro Beacon E 1945 - Iwo Jima	ATF	20	0	145.0	75.0	-272.0
174	Astro Tern Island (Frig) 1961 - Tern Island	TRN	20	0	114.0	-116.0	-333.0
175	Astronomical Station 1952 - Marcus Island	ASQ	20	0	124.0	-234.0	-25.0
176	Bellevue (IGN) - Efate and Erromango Islands	IBE	20	0	-127.0	-769.0	472.0
177	Canton Astro 1966 - Phoenix Islands	CAO	20	0	298.0	-304.0	-375.0
178	Chatham Island Astro 1971 - Chatham Island (New Zealand)	CHI	20	0	175.0	-38.0	113.0
179	DOS 1968 - Gizo Island (New Georgia Islands)	GIZ	20	0	230.0	-199.0	-752.0
180	Easter Island 1967 - Easter Island	EAS	20	0	211.0	147.0	111.0
181	Geodetic Datum 1949 - New Zealand	GEO	20	0	84.0	-22.0	209.0
182	Guam 1963 - Guam Island	GUA	6	0	-100.0	-248.0	259.0
183	GUX 1 Astro - Guadalcanal Island	DOB	20	0	252.0	-209.0	-751.0
184	Indonesian 1974 - Indonesia	IDN	19	0	-24.0	-15.0	5.0
185	Johnston Island 1961 - Johnston Island	JOH	20	0	189.0	-79.0	-202.0
186	Kusaie Astro 1951 - Caroline Islands, Fed. States of Micronesia	KUS	20	0	647.0	1777.0	-1124.0
187	Luzon - Philippines (excluding Mindanao Island)	LUZ-A	6	0	-133.0	-77.0	-51.0
188	Luzon - Mindanao Island (Philippines)	LUZ-B	6	0	-133.0	-79.0	-72.0
189	Midway Astro 1961 - Midway Islands	MID	20	0	912.0	-58.0	1227.0
190	Old Hawaiian - Mean Solution	OHA-M	6	0	61.0	-285.0	-181.0
191	Old Hawaiian - Hawaii	OHA-A	6	0	89.0	-279.0	-183.0
192	Old Hawaiian - Kauai	OHA-B	6	0	45.0	-290.0	-172.0
193	Old Hawaiian - Maui	OHA-C	6	0	65.0	-290.0	-190.0
194	Old Hawaiian - Oahu	OHA-D	6	0	58.0	-283.0	-182.0
195	Pitcairn Astro 1967 - Pitcairn Island	PIT	20	0	185.0	165.0	42.0
196	Santo (Dos) 1965 - Espirito Santo Island	SAE	20	0	170.0	42.0	84.0
197	Viti Levu 1916 - Viti Levu Island (Fiji Islands)	MVS	7	0	51.0	391.0	-36.0
198	Wake-Eniwetok 1960 - Marshall Islands	ENW	18	0	102.0	52.0	-38.0
199	Wake Island Astro 1952 - Wake Atoll	WAK	20	0	276.0	-57.0	149.0
200	Bukit Rimpah - Bangka and Belitung Islands (Indonesia)	BUR	5	0	-384.0	664.0	-48.0
201	Camp Area Astro - Camp McMurdo Area, Antarctica	CAZ	20	0	-104.0	-129.0	239.0
202	European 1950 - Iraq, Israel, Jordan, Kuwait, Lebanon, Saudi Arabia & Syria	EUR-S	20	0	-103.0	-106.0	-141.0
203	Gunung Segara - Kalimantan (Indonesia)	GSE	5	0	-403.0	684.0	41.0
204	Herat North - Afghanistan	HEN	20	0	-333.0	-222.0	114.0
205	Indian - Pakistan	IND-P	9	0	283.0	682.0	231.0

Index	Name	Acronym	Ellipsoid index (see Table 76)	Rotation and scale index (see Table 77)	dX [m]	dY [m]	dZ [m]
206	Pulkovo 1942 - Russia	PUK	21	0	28.0	-130.0	-95.0
207	Tananarive Observatory 1925 - Madagascar	TAN	20	0	-189.0	-242.0	-91.0
208	Yacare - Uruguay	YAC	20	0	-155.0	171.0	37.0
209	Krassovsky 1942 - Russia	KRA42	21	0	26.0	-139.0	-80.0
210	Lommel Datum 1950 - Belgium & Luxembourg	BLG50	20	0	-55.0	49.0	-158.0
211	Reseau National Belge 1972 - Belgium	RNB72	20	0	-104.0	80.0	-75.0
212	NTF - Nouvelle Triangulation de la France	NTF	7	0	-168.0	-60.0	320.0
213	Netherlands 1921 - Netherlands	NL21	5	0	719.0	47.0	640.0
214	European Datum 1987, IAG RETrig Subcommision.	ED87	20	2	-82.5	-91.7	-117.7
215	Swiss Datum 1903+ (LV95)	CH95	5	0	674.374	15.056	405.346

**Table 75: Datum**

Index	Ellipsoid	Semi Major Axis [m]	1/Flattening
0	WGS 84	6378137.000	298.257223563
1	Airy 1830	6377563.396	299.3249646
2	Modified Airy	6377340.189	299.3249646
3	Australian National	6378160.000	298.25
4	Bessel 1841 (Namibia)	6377483.865	299.1528128
5	Bessel 1841	6377397.155	299.1528128
6	Clarke 1866	6378206.400	294.9786982
7	Clarke 1880	6378249.145	293.465
8	Earth-90	6378136.000	298.257839303
9	Everest (India 1830)	6377276.345	300.8017
10	Everest (Sabah Sarawak)	6377298.556	300.8017
11	Everest (India 1956)	6377301.243	300.8017
12	Everest (Malaysia 1969)	6377295.664	300.8017
13	Everest (Malay. & Singapore 1948)	6377304.063	300.8017
14	Everest (Pakistan)	6377309.613	300.8017
15	Modified Fischer 1960	6378155.000	298.3
16	GRS 80	6378137.000	298.257222101
17	Helmert 1906	6378200.000	298.3
18	Hough 1960	6378270.000	297.0
19	Indonesian 1974	6378160.000	298.247
20	International 1924	6378388.000	297.0
21	Krassovsky 1940	6378245.000	298.3
22	South American 1969	6378160.000	298.25
23	WGS 72	6378135.000	298.26

**Table 76: Ellipsoids**



Index	Description	Rot X [seconds]	Rot Y [seconds]	Rot Z [seconds]	Scale [-]
0		+0.0000	+0.0000	+0.0000	0.000
1		0.0000	0.0000	-0.5540	0.220
2	European Datum 1987 IAG RETrig Subcommision	0.1338	-0.0625	-0.0470	0.045

**Table 77: Rotation and scale**

## C Demo Design

### C.1 TIM - GPS standalone Receiver

#### C.1.1 Schematic

Please refer to *Section 3* to implement your individual needs for your GPS standalone receiver.

#### C.1.2 Bill of Material

There is not additional components needed to design an ANTARIS® GPS receiver. If the optional active antenna supervisor circuitry is required then refer to *Section 4.3*.

#### C.1.3 Layout

*Figure 118* and *Figure 119* show examples of an application board based on u-blox PS2 board. One can easily identify the large number of vias and the ground areas on the top layer. Since the dielectric is rather thick (1.6 mm) also the micro strip gets quite wide. Unfortunately, the mounting hole in the upper left corner required a trench in the micro strip line. Measurements show that this has no significant effect. The small slot in the ground plane on the bottom layer at the left end helps to isolate the noisy digital part from the RF input. This was necessary in this design because the RF connector sits quite close to the digital I/Os of the receiver. If in a different design, the connector could be moved further up, the slot would likely not be necessary and a layout similar to *Figure 43* will work fine. Increasing the length of this slot is not recommended and will not further improve performance.

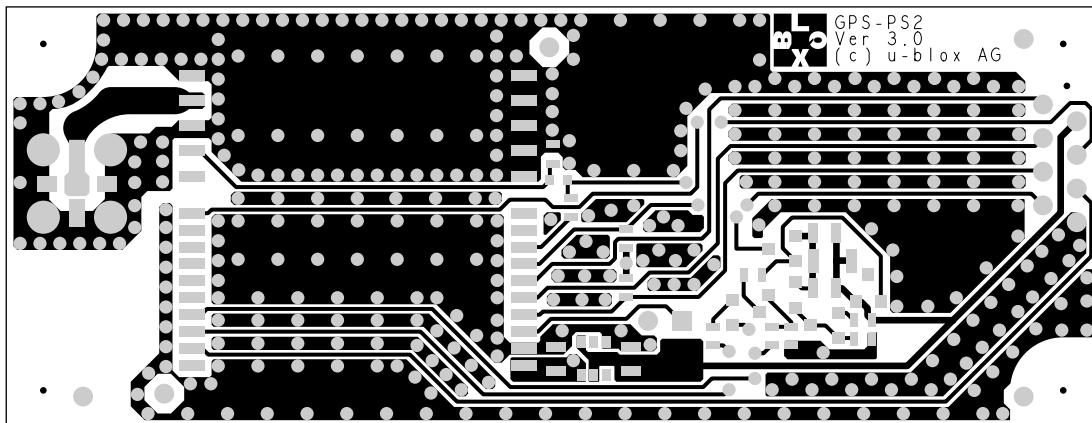

**Figure 118: Reference layout: Top layer on 2-layer 1.6 mm FR-4 material**

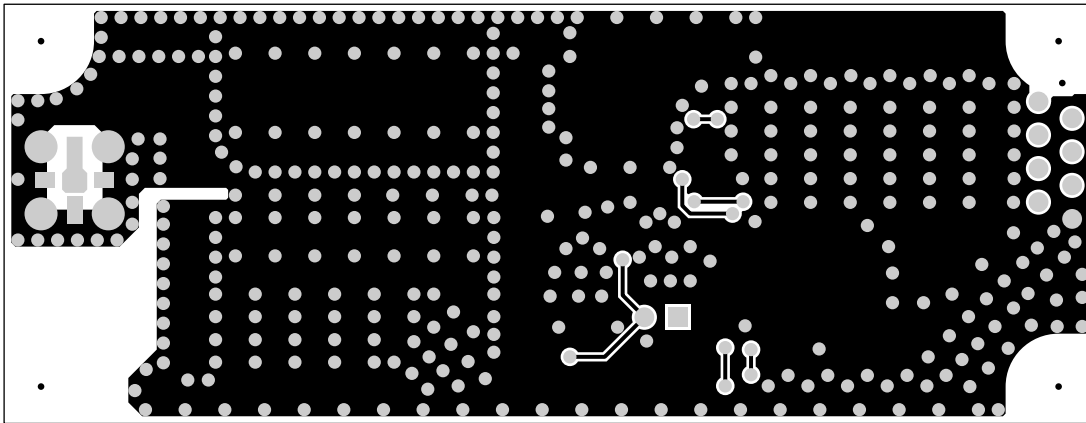

Figure 119: Reference layout: Bottom layer on 2-layer 1.6 mm FR-4 material

**Note** u-blox offers a PCB review support for your design to assure good GPS performance. Please contact your local u-blox office already in an early stage of your design process for optimal guidance.

## C.2 LEA – Smart Antenna

A4

The following design does support all LEA modules on one PCB and features one serial port as well as a USB connection. If USB is not needed some components can be spared.

**Note** For this design u-blox can provide you a complete Smart Antenna Demo Design including Schematic, Gerber Files, PCB blueprint and recommendations. Please contact u-blox support for further information. Conditions applied.

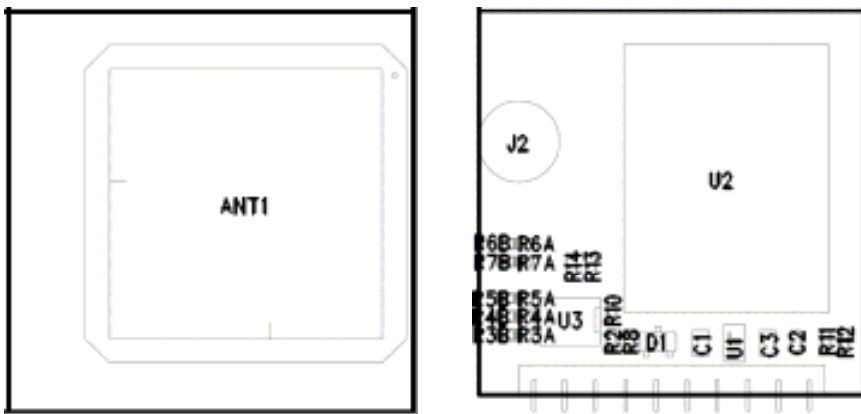

Figure 120: LEA-Smart Antenna (top view/ bottom view)

### C.2.1 Schematic

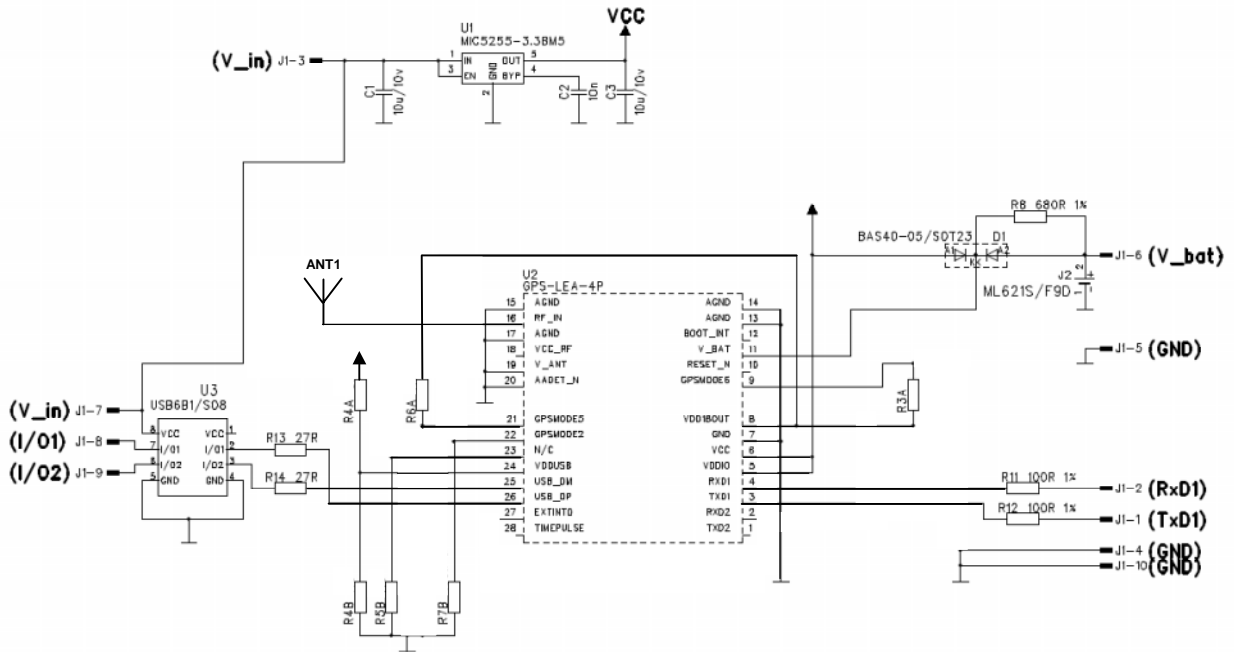

Figure 121: LEA Smart Antenna Schematic

Some of the passive components (Resistors) can be neglected, if the design does not have to support Low Cost Modules (like LEA-4A).

## C.2.2 Bill of Material

	Part description	Remarks
ANT1	25 x 25mm Ceramic Patch Antenna	e.g. EMTAC ANR1580M25B4, e.g. F0=1580
C1, C3	10 $\mu$ , 20%, S1210	
C2	10n, 10%, S0603	
D1	Schottky diode, e.g. BSA40-05	Only required if optional battery J2 is used.
J1	10-pin connector, 2.54mm pitch	e.g. Molex 7395 right angle header
J2	Sanyo ML621-TZ1 Rechargeable Li Battery	Optional. If not used, connect pin J1-6 to battery on motherboard or to GND.
R3A	100k Resistor, 10%, S0603, 0.063W	GPSMODE6, see also section 4.8.2.3. For LEA-4S and LEA-4A, fit R3B or leave open. Leave R3B open for LEA-4H and LEA-4P designs.
R4A, R4B	0R Resistor, S0603	Fit R4A if USB is used, otherwise fit R4B.
R5B	0R Resistor, S0603	GPSMODE7, see also section 4.8.2.4. Fit R5B if USB is "Bus Powered". Leave open if USB is "self-powered" or not used at all.
R6A	100k Resistor, 10%, S0603, 0.063W	GPSMODE5, see also section 4.8.2.3. Do not fit R6B. For LEA-4S and LEA-4A, fit R6A or leave open. Leave R6A open for LEA-4H and LEA-4P designs.
R7B	100k Resistor, 10%, S0603, 0.063W	GPSMODE2 / GPSMODE23, see also section 4.8.2.2. Do not fit R7A. For LEA-4S and LEA-4A, fit R7B or leave open. Leave R7B open for LEA-4H and LEA-4P designs.
R8	680R Resistor, 10%, S0603, 0.063W	Required if optional battery J2 is used. Otherwise, use a 0R resistor.
R11, R12	100R Resistor, 10%, S0603, 0.063W	Do not fit if USART (Rx/D1/TxD1) is not used
R13, R14	27R Resistor, 10%, S0603, 0.063W	Do not fit if USB is not used
U1	Micrel LDO MIC5255-3.3YM5, SSOT23_5	
U2	LEA-4x module	
U3	USB6B1, S08, ST Microelectronics	Do not fit if USB is not used

**Table 78: Bill of Material**

- ☞ **Note:** Depending on the required interface (USB or UART), several parts don't have to be fit. The same applies to the backup battery if an external backup supply is available. Refer to **Table 78** for the feasible options.

### C.2.3 Layout

The layout is designed for a 2-layer 1mm FR4 PCB board.

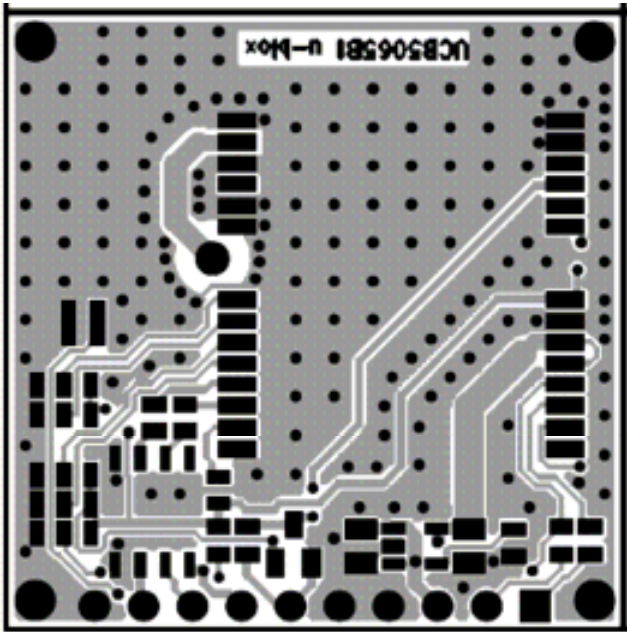

Figure 122: Top Layer

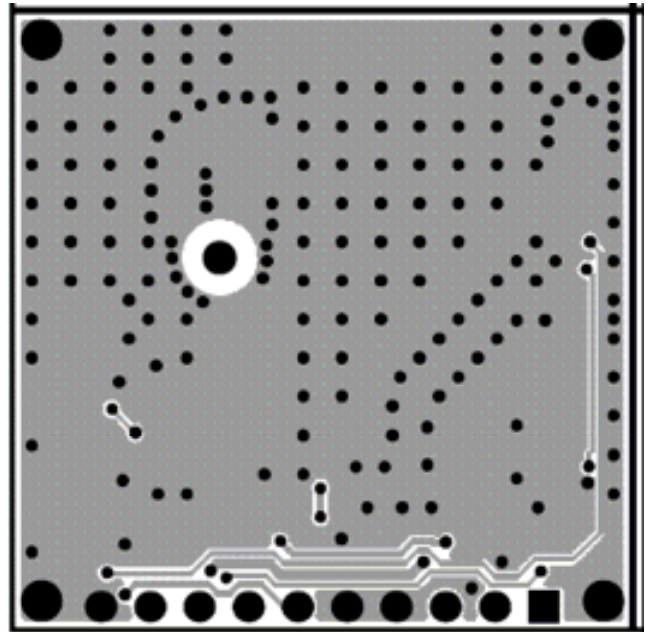

Figure 123: Bottom Layer

# D Migration to ANTARIS<sup>®</sup> 4 receivers

Migrating ANTARIS<sup>®</sup> to an ANTARIS<sup>®</sup>4 GPS receiver is a very straightforward procedure. Nevertheless there are some points to be considered during the migration.

## D.1 Software Changes

< Firmware 5.00 or < ROM5	Firmware 5.00 or ROM5	Remarks
UBX-CFG-NAV	UBX-CFG-NAV2	To ease the navigation configuration u-blox has introduced a new message. It has also additional features. UBX-CFG-NAV is not supported anymore on ANTARIS <sup>®</sup> 4. See also <i>Section 4.6</i> .
UBX-TIM-TM UBX-CFG-TM	N/A	Time mark feature Starting with firmware version 5.0, these messages are not longer supported!
N/A	UBX-TIM-TM2 UBX-CFG-TM2	Improved Time Mark feature. Only supported on LEA-4T.
UBX-RXM-RAW UBX-RXM-SFRB	UBX-RXM-RAW UBX-RXM-SFRB	Satellite RAW and subframe data. These messages have the same format as on ANTARIS <sup>®</sup> but on ANTARIS <sup>®</sup> 4 receivers they are only supported on LEA-4T receivers.

## D.2 Migration from LEA-LA to LEA-4A/LEA-4S

The pin-outs of LEA-LA and LEA-4A/LEA-4S modules do not differ significantly. *Table 79* compares the modules and highlights the differences to be considered.

Pin	LEA-LA		LEA-4A / LEA-4S		Remarks for Migration
	Pin Name	Typical Assignment	Pin Name	Typical Assignment	
1	TXD2	VDDIO level I/O	TXD2	VDDIO level I/O	No difference.
2	RXD2	VDDIO level I/O; pull up if not used	RXD2	VDDIO level I/O; not connected	Do not add an external pull up resistor; there is one built-in to <b>V_BAT</b> . Leave open if not used.
3	TXD1	VDDIO level I/O	TXD1	VDDIO level I/O	No difference
4	RXD1	VDDIO level I/O; pull up if not used	RXD1	VDDIO level I/O	Do not add an external pull up resistor; there is one built-in to <b>V_BAT</b> . Leave open if not used.
5	VDDIO	1.65 – 3.60V	VDDIO	1.65 – 3.60V	To be compatible to LEA-LA, <b>VDDIO</b> has to be set to Vcc to assure a 3.0V level at the serial ports. The GPSMODE pins do recognize 1.8V and 3.0V as “high” value at <b>VDDIO</b> .
6	VCC	2.70 – 3.30V	VCC	2.70 – 3.30V	No difference
7	GND	GND	GND	GND	No difference
8	VDD18OUT	Not connected	VDD18OUT	Not connected	No difference
9	GPSMODE6	Connected to GND or VDD_18OUT	GPSMODE6	Not connected	Backward compatible: This pin can be connected to GND, VDD18OUT or VCC. An external pull up resistor is not required as there is one built-in.
10	RESET_N	1.8V	RESET_N	1.8V	No difference (see <i>Section 4.9.2</i> ).
11	V_BAT	1.95 – 3.6V	V_BAT	1.50 – 3.6V	Wider voltage range. Uncritical for migration.
12	BOOT_INT	NC	BOOT_INT	NC	No difference
13	GND	GND	GND	GND	No difference
14	GND	GND	GND	GND	No difference
15	GND	GND	GND	GND	No difference
16	RF_IN	RF_IN	RF_IN	RF_IN	No difference
17	GND	GND	GND	GND	No difference
18	VCC_RF	VCC - 0.1V	VCC_RF	VCC - 0.1V	No difference
19	V_ANT	3.0V – 5.0V	V_ANT	3.0V – 5.0V	No difference
20	AADET_N	Connected to GND	AADET_N	Not connected	No external pull down resistor required, as there is already an internal pull down resistor. Please check resistor values in <i>Section 4.3.3.2</i>
21	GPSMODE5	Connected to GND or VDD_18OUT	GPSMODE5	Not connected	Backward compatible: This pin can be connected to GND, VDD18OUT or VCC. An external pull up resistor is not required as there is one built-in.

Pin	LEA-LA		LEA-4A / LEA-4S		Remarks for Migration
	Pin Name	Typical Assignment	Pin Name	Typical Assignment	
22	<b>GPSMODE2</b>	Connected to GND or VDD_18OUT	<b>GPSMODE2/ GPSMODE23<sup>25</sup></b>	Not connected	Backward compatible: This pin can be connected to GND, VDD18OUT or VCC. An external pull up resistor is not required as there is one built-in.
23	<b>NC</b>	Not connected	<b>GPSMODE7</b>	Not connected	Placing a LEA-4x into an existing LEA-LA board design will disable USB port.
24	<b>NC</b>	Connected to GND	<b>VDDUSB</b>	Connected to GND	
25	<b>NC</b>	Not connected	<b>USB_DM</b>	Not connected	
26	<b>NC</b>	Not connected	<b>USB_DP</b>	Not connected	
27	<b>EXTINT0</b>	Connected to VDD18OUT	<b>EXTINT0</b>	Not connected	Do not add an external pull up resistor; there is one built-in to <b>V_BAT</b> . Leave open if not used.
28	<b>TIMEPULSE</b>	1.8V out	<b>TIMEPULSE</b>	VDDIO level I/O	Consider that <b>TIMEPULSE</b> on LEA-4x is on <b>VDDIO</b> voltage level (1.8V on LEA-LA)

  : Pins to be checked carefully

**Table 79: Pin-out comparison LEA-LA vs. LEA-4A/4S**

### D.3 Migration from LEA-LA to LEA-4H/LEA-4P

The pin-outs of LEA-LA and LEA-4H/4P differ slightly. *Table 80* compares the modules and highlights the differences to be considered.

Pin	LEA-LA		LEA-4H / LEA-4P		Remarks for Migration
	Pin Name	Typical Assignment	Pin Name	Typical Assignment	
1	<b>TXD2</b>	VDDIO level I/O	<b>MISO</b>	VDDIO level I/O; not connected	Serial Port 2 not supported on LEA-4P/LEA-4H. Leave open if not used.
2	<b>RXD2</b>	VDDIO level I/O; pull up if not used	<b>MOSI</b>	VDDIO level I/O; not connected	
3	<b>TXD1</b>	VDDIO level I/O	<b>TXD1</b>	VDDIO level I/O	No difference
4	<b>RXD1</b>	VDDIO level I/O; pull up if not used	<b>RXD1</b>	VDDIO level I/O	Do not add an external pull up resistor; there is one built-in to <b>V_BAT</b> . Leave open if not used.
5	<b>VDDIO</b>	1.65 – 3.60V	<b>VDDIO</b>	1.65 – 3.60V	To be compatible to LEA-LA, <b>VDDIO</b> has to be set to Vcc to assure a 3.0V level at the serial ports. The GPSMODE pins do recognize 1.8V and 3.0V as “high” value at <b>VDDIO</b> .
6	<b>VCC</b>	2.70 – 3.30V	<b>VCC</b>	2.70 – 3.30V	No difference
7	<b>GND</b>	GND	<b>GND</b>	GND	No difference
8	<b>VDD18OUT</b>	Not connected	<b>VDD18OUT</b>	Not connected	No difference
9	<b>GPSMODE6</b>	Connected to GND or VDD_18OUT	<b>PCS0_N</b>	Not connected	Backward compatible: can be left open or connected to GND, VDDIO or VDD_18OUT.
10	<b>RESET_N</b>	1.8V	<b>RESET_N</b>	1.8V	No difference (see <i>Section 4.9.2</i> ).
11	<b>V_BAT</b>	1.95 – 3.6V	<b>V_BAT</b>	1.50 – 3.6V	Wider voltage range. Uncritical for migration.
12	<b>BOOT_INT</b>	NC	<b>BOOT_INT</b>	NC	No difference
13	<b>GND</b>	GND	<b>GND</b>	GND	No difference
14	<b>GND</b>	GND	<b>GND</b>	GND	No difference
15	<b>GND</b>	GND	<b>GND</b>	GND	No difference
16	<b>RF_IN</b>	RF_IN	<b>RF_IN</b>	RF_IN	No difference
17	<b>GND</b>	GND	<b>GND</b>	GND	No difference
18	<b>VCC_RF</b>	VCC - 0.1V	<b>VCC_RF</b>	VCC - 0.1V	No difference
19	<b>V_ANT</b>	3.0V – 5.0V	<b>V_ANT</b>	3.0V – 5.0V	No difference
20	<b>AADET_N</b>	Connected to GND	<b>AADET_N</b>	Not connected	No external pull down resistor required, as there is already an internal pull down resistor. Please check resistor values in <i>Section 4.3.3.2</i> .
21	<b>GPSMODE5</b>	Connected to GND or VDD_18OUT	<b>EXTINT1</b>	Not connected	Do not add an external pull up resistor; there is one built-in. Leave open if not used. If permanently connected to GND, the FixNOW sleep

<sup>25</sup> Connecting the GPSMODE23 pin (LEA-4S) to GND increased the FixNOW sleep mode current by about 50µA. Connecting the GPSMODE2 pin (LEA-4A) to GND does however not have an impact on the FixNOW sleep mode current.



Pin	LEA-LA		LEA-4H / LEA-4P		Remarks for Migration
	Pin Name	Typical Assignment	Pin Name	Typical Assignment	
					mode is increased by up to 50µA
22	<b>GPSMODE2</b>	Connected to GND or VDD_18OUT	<b>PCS2_N</b>	Not connected	Backward compatible: can be left open or connected to GND, VDDIO or VDD_18OUT.
23	<b>NC</b>	Not connected	<b>SCK</b>	Not connected	Placing a LEA-4x into an existing LEA-LA board design will disable USB port.
24	<b>NC</b>	Connected to GND	<b>VDDUSB</b>	Connected to GND or VDD_USB	
25	<b>NC</b>	Not connected	<b>USB_DM</b>	Not connected	
26	<b>NC</b>	Not connected	<b>USB_DP</b>	Not connected	
27	<b>EXTINT0</b>	Connected to VDD18OUT	<b>EXTINT0</b>	Not connected	Do not add an external pull up resistor; there is one built-in to <b>V_BAT</b> . Leave open if not used.
28	<b>TIMEPULSE</b>	1.8V out	<b>TIMEPULSE</b>	VDDIO level I/O	Consider that <b>TIMEPULSE</b> on LEA-4x is on <b>VDDIO</b> voltage level (1.8V on LEA-LA)

  : Pins to be checked carefully

**Table 80: Pin-out comparison LEA-LA vs. LEA-4x**

## D.4 Migration from TIM-Lx to TIM-4x pin out

The pin-outs of TIM-Lx and TIM-4x modules do not differ significantly. *Table 81* compares the modules and highlights the differences to be considered. Please note that this table does not consider any migration from TIM-LR.

Pin	TIM-Lx		TIM-4x		Remarks
	Pin Name	Typical Assignment	Pin Name	Typical Assignment	
1	VCC	2.70 – 3.30V	VCC	2.70 – 3.30V	No difference
2	GND	GND	GND	GND	No difference
3	BOOT_INT	NC	BOOT_INT	NC	No difference
4	RXD1	3.0V in; pull up to VCC if not used	RXD1	1.8 - 5.0V in	Do not add an external pull up resistor; there is one built-in to <b>V_BAT</b> . Leave open if not used.
5	TXD1	3.0V out	TXD1	3.0V out	No difference
6	TXD2	3.0V out	TXD2	3.0V out	No difference
7	RXD2	3.0V in; pull up to VCC if not used	RXD2	1.8 - 5.0V in	Do not add an external pull up resistor; there is one built-in to <b>V_BAT</b> . Leave open if not used.
8	P17 / GPSMODE5	1.8V I/O (LP: 3.0V), not connected	P17/ GPSMODE5	3.0V I/O, not connected	No difference <sup>26</sup>
9	STATUS / GPSMODE3	1.8V I/O (LP: 3.0V), not connected	EXTINT1 / GPSMODE3	3.0V I/O, not connected	Status Pin not available anymore; No difference otherwise.
10	VDD18_OUT / TIM-LP: NC/GND	Not connected	VDD18OUT	Not connected	No difference, except for <b>TIM-LP</b> .
11 to 16	GND	GND	GND	GND	No difference
17	RF_IN	RF_IN	RF_IN	RF_IN	No difference
18	GND	GND	GND	GND	No difference
19	V_ANT	3.0V -5.0V	V_ANT	3.0V -5.0V	No difference
20	VCC_RF	VCC - 0.1V	VCC_RF	VCC - 0.1V	No difference
21	V_BAT	1.95 – 3.6V	V_BAT	1.50 – 3.6V	Wider voltage range. Uncritical for migration.
22	RESET_N	1.8V	RESET_N	1.8V	No difference. Don't drive high. Refer to <i>Section 4.9.2</i> for more information.
23	EXTINT0	Not connected	EXTINT0	Not connected	No difference
24	PCS1_N/ GPSMODE2	1.8V I/O (LP: 3.0V), not connected	PCS1_N/ GPSMODE2	3.0V I/O, not connected	No difference
25	PCS0_N/ GPSMODE6		PCS0_N/ GPSMODE6		No difference
26	SCK/ GPSMODE7		SCK/ NC		No difference on Programmable receivers. But on TIM-4A: the Navigation rate cannot be changed anymore. It's always 1Hz.
27	AADET_N	Not connected	AADET_N	Not connected	No external pull down resistor required as there is already an internal pull down register. Please check resistor values in <i>Section 4.3.3.2</i> .
28	MOSI/ GPSMODE8	1.8V I/O (LP: 3.0V), not connected	MOSI/ P24	3.0V I/O, not connected	No difference on Programmable receivers. But on TIM-4A/ TIM-4S: the Navigation rate cannot be changed anymore. It's always 1Hz.
29	TIMEPULSE	1.8V out (LP: 3.0V)	TIMEPULSE	3.0V out	Same function but different output voltage.
30	PCS3_N/ GPSMODE12	1.8V I/O (LP: 3.0V), not connected	PCS3_N/ GPSMODE 12	3.0V I/O, not connected	No difference

 : Pins to be checked carefully

**Table 81: Pin-out comparison TIM-Lx vs. TIM-4x**

<sup>26</sup> Higher output voltage is only significant when using GPIO pin functionality together with an SCKit application.

## D.5 Pin Comparison ANTARIS® to ANTARIS®4

Pin	ANTARIS®								ANTARIS®4				Pin
	TIM-LA /TIM-LC		TIM-LL/ TIM-LF/ TIM-LH		TIM-LP		TIM-LR		TIM-4A/ TIM-4S		TIM-4P/ TIM-4H		
	Pin Name	Typical Assignment	Pin Name	Typical Assignment	Pin Name	Typical Assignment	Pin Name	Typical Assignment	Pin Name	Typical Assignment	Pin Name	Typical Assignment	
1	VCC	2.70 – 3.30V	VCC	2.70 – 3.30V	VCC	2.70 – 3.30V	VCC	2.70 – 3.30V	VCC	2.70 – 3.30V	VCC	2.70 – 3.30V	1
2	GND	GND	GND	GND	GND	GND	GND	GND	GND	GND	GND	GND	2
3	BOOT_INT	NC	BOOT_INT	NC	BOOT_INT	NC	BOOT_INT	NC	BOOT_INT	NC	BOOT_INT	NC	3
4	RXD1	3.0V in	RXD1	3.0V in	RXD1	3.0V in	RXD1	3.0V in	RXD1	1.8 - 5.0V	RXD1	1.8 - 5.0V	4
5	TXD1	3.0V out	TXD1	3.0V out	TXD1	3.0V out	TXD1	3.0V out	TXD1	3.0V out	TXD1	3.0V out	5
6	TXD2	3.0V in	TXD2	3.0V out	TXD2	3.0V out	TXD2	3.0V out	TXD2	3.0V out	TXD2	3.0V out	6
7	RXD2	3.0V out	RXD2	3.0V in	RXD2	3.0V in	RXD2	3.0V in	RXD2	1.8 - 5.0V	RXD2	1.8 - 5.0V	7
8	GPSPMODE5	NC (1.8V)	SCK1/ P17	NC (1.8V)	SCK1/ P17	NC (3.0V)	FWD	Direction (1.8V)	GPSPMODE5	NC (3.0V)	SCK1/ P17	NC (3.0V)	8
9	GPSPMODE3	NC (1.8V)	STATUS	NC (1.8V)	STATUS	NC (3.0V)	STATUS	NC (1.8V)	GPSPMODE3/23	NC (3.0V)	EXTINT1/P13	NC (3.0V)	9
10	VDD18OUT	NC	VDD18OUT	NC	RESERVED	NC	VDD18OUT	NC	VDD18OUT	NC	VDD18OUT	NC	10
11 to 16	GND	GND	GND	GND	GND	GND	GND	GND	GND	GND	GND	GND	11 to 16
17	RF_IN	RF_IN	RF_IN	RF_IN	RF_IN	RF_IN	RF_IN	RF_IN	RF_IN	RF_IN	RF_IN	RF_IN	17
18	GND	GND	GND	GND	GND	GND	GND	GND	GND	GND	GND	GND	18
19	V_ANT	3.0V - 5.0V	V_ANT	3.0V - 5.0V	V_ANT	3.0V - 5.0V	V_ANT	3.0V - 5.0V	V_ANT	3.0V - 5.0V	V_ANT	3.0V - 5.0V	19
20	VCC_RF	VCC - 0.1V	VCC_RF	VCC - 0.1V	VCC_RF	VCC - 0.1V	VCC_RF	VCC - 0.1V	VCC_RF	VCC - 0.1V	VCC_RF	VCC - 0.1V	20
21	V_BAT	1.95 – 3.6V	V_BAT	1.95 – 3.6V	V_BAT	1.95 – 3.6V	V_BAT	1.95 – 3.6V	V_BAT	1.50 – 3.6V	V_BAT	1.50 – 3.6V	21
22	RESET_N	ACTIVE LOW	RESET_N	ACTIVE LOW	RESET_N	ACTIVE LOW	RESET_N	ACTIVE LOW	RESET_N	ACTIVE LOW	RESET_N	ACTIVE LOW	22
23	EXTINT0	NC (1.8V)	EXTINT0/ P9	NC (1.8V)	EXTINT0/ P9	NC (3.0V)	SPEED	Wheel Tick (1.8V)	EXTINT0	NC (3.0V)	EXTINT0/ P9	NC (3.0V)	23
24	GPSPMODE2	NC (1.8V)	PCS1_N/ P27	NC (1.8V)	PCS1_N/ P27	NC (3.0V)	PCS1_N	SPI (1.8V)	GPSPMODE2	NC (3.0V)	PCS1_N/ P27	NC (3.0V)	24
25	GPSPMODE6	NC (1.8V)	PCS0_N/ SS_N/ P26	NC (1.8V)	PCS0_N/ SS_N/ P26	NC (3.0V)	PCS0_N	SPI (1.8V)	GPSPMODE6	NC (3.0V)	PCS0_N/ SS_N/ P26	NC (3.0V)	25
26	GPSPMODE7	NC (1.8V)	SCK/ P23	NC (1.8V)	SCK/ P23	NC (3.0V)	SCK	SPI (1.8V)	NC	NC	SCK/ P23	NC (3.0V)	26
27	AADET_N	NC (1.8V)	AADET_N	NC (1.8V)	AADET_N	NC (3.0V)	MISO	SPI (1.8V)	AADET_N	NC (3.0V)	AADET_N	NC (3.0V)	27
28	GPSPMODE8	NC (1.8V)	MOSI/ P24	NC (1.8V)	MOSI/ P24	NC (3.0V)	MOSI	NC (1.8V)	P24	NC	MOSI/ P24	NC (3.0V)	28
29	TIMEPULSE	1.8V out	TIMEPULSE	1.8V out	TIMEPULSE	3.0V out	TIMEPULSE	1.8V out	TIMEPULSE	3.0V out	TIMEPULSE	3.0V out	29
30	GPSPMODE12	NC (1.8V)	PCS3_N/ P29	NC (1.8V)	PCS3_N/ P29	NC (3.0V)	AADET_N	NC (1.8V)	GPSPMODE12	NC (3.0V)	PCS3_N/ P29	NC (3.0V)	30

⚠ : Pins to be checked carefully; NC: Not connected

**Table 82: Typical Pin Assignment TIM modules**

Pin	ANTARIS®		ANTARIS® 4				Pin
	LEA-LA		LEA-4A/ LEA-4S		LEA-4P/ LEA-4H/ LEA-4T		
	Pin Name	Typical Assignment	Pin Name	Typical Assignment	Pin Name	Typical Assignment	
1	TxD2	3.0V out	TxD2	3.0V out	MOSI	NC	1
2	RxD2	3.0V in	RxD2	1.8 - 5.0V	MISO	NC	2
3	TxD1	3.0V out	TxD1	3.0V out	TxD1	3.0V out	3
4	RxD1	3.0V in	RxD1	1.8 - 5.0V in	RxD1	1.8 - 5.0V in	4
5	VDDIO	VCC	VDDIO	VCC	VDDIO	VCC	5
6	VCC	2.70 – 3.30V	VCC	2.70 – 3.30V	VCC	2.70 – 3.30V	6
7	GND	GND	GND	GND	GND	GND	7
8	VDD18OUT	1.8V out	VDD18OUT	1.8V out	VDD18OUT	1.8V out	8
9	GPSPMODE6	NC (GND or VDD18OUT)	GPSPMODE6	NC (GND or VDD18OUT)	PCS0_N/ SS_N/ P26	NC (3.0V)	9
10	RESET_N	ACTIVE LOW	RESET_N	ACTIVE LOW	RESET_N	ACTIVE LOW	10
11	V_BAT	1.95 – 3.6V	V_BAT	1.50 – 3.6V	V_BAT	1.50 – 3.6V	11
12	BOOT_INT	NC	BOOT_INT	NC	BOOT_INT	NC	12
13	GND	GND	GND	GND	GND	GND	13
14	GND	GND	GND	GND	GND	GND	14
15	GND	GND	GND	GND	GND	GND	15
16	RF_IN	RF_IN	RF_IN	RF_IN	RF_IN	RF_IN	16
17	GND	GND	GND	GND	GND	GND	17
18	VCC_RF	VCC - 0.1V	VCC_RF	VCC - 0.1V	VCC_RF	VCC - 0.1V	18
19	V_ANT	3.0V - 5.0V	V_ANT	3.0V - 5.0V	V_ANT	3.0V - 5.0V	19
20	AADET_N	NC (1.8V)	AADET_N	NC (1.8 to 5.0V)	AADET_N	NC (1.8 to 5.0V)	20
21	GPSPMODE5	NC (GND or VDD18OUT)	GPSPMODE5	NC (GND or VDD18OUT)	EXTINT1/ P13	NC (1.8 to 5.0V)	21
22	GPSPMODE2	NC (GND or VDD18OUT)	GPSPMODE2 / GPSPMODE23	NC (GND or VDD18OUT)	PCS2_N/ P12	NC (1.8 to 5.0V)	22
23	N/C	NC (1.8V)	GPSPMODE7	NC (1.8 to 5.0V)	SCK/ P23	NC (1.8 to 5.0V)	23
24	N/C	GND	VDDUSB	3.0 – 3.6V/ GND	VDDUSB	3.0 – 3.6V/ GND	24
25	N/C	NC (1.8V)	USB_DM	VDDUSB I/O	USB_DM	VDDUSB I/O	25
26	N/C	NC (1.8V)	USB_DP	VDDUSB I/O	USB_DP	VDDUSB I/O	26
27	EXTINT0	NC (1.8V)	EXTINT0	NC (1.8 to 5.0V)	EXTINT0/ P9	NC (1.8 to 5.0V)	27
28	TIMEPULSE	1.8V out	TIMEPULSE	VDDIO out	TIMEPULSE	VDDIO out	28

: Pins to be checked carefully; NC: Not connected

Table 83: Typical Pin Assignment LEA modules

## D.6 Migration from TIM-ST to TIM-4x

Migrating a TIM-ST design to one of the TIM-4x GPS receivers is usually an easy, straightforward procedure. This section summarizes most important differences.

### NMEA Protocol

TIM-ST and TIM-Lx output NMEA data (GGA, GLL, GSA, GSV, RMC, VTG and ZDA messages) on port 1.

TIM-ST	TIM-4x (ANTARIS®4)	Remarks
NMEA V2.2	NMEA V2.3	Most NMEA parsers should be able to handle V2.2 and V2.3. Should your parser struggle with V2.3, configure TIM-4x to output NMEA V2.1 by sending an UBX-CFG-NMEA message.
12 channels	16 channels	ANTARIS®4 is able to track up to 16 satellites in parallel. Since one GSV message contains only up to 4 satellites, ANTARIS may send up to 4 GSV messages whereas TIM-ST only output 3. If this causes problem, reduce the NMEA output of ANTARIS to 12 satellites by sending a CFG-NMEA message
Lat and Long are output in case of invalid fixes	Lat and Long are only output for valid fixes	ANTARIS®4 can be reconfigured to output Lat and Long in case of invalid fixes by sending an UBX-CFG-NMEA message.
Accepts position up to a PDOP of 50	Accepts position up to a PDOP of 25	ANTARIS®4 receivers are more sensitive than TIM-ST. Hence the more conservative approach with a PDOP of 25 works usually fine. However, it's possible to configure TIM-Lx to accept position with a higher PDOP by sending a UBX-CFG-NAV2 message
Lat and Long are output with 4, the time with 3 position after decimal point	Lat and Long are output with 5, the time with 2 position after decimal point	The NMEA specification is fairly open and allows minor variations in the implementation (e.g. number of position after decimal point, etc.) but it always requests commas between as a separator between NMEA data fields. One should therefore write a parser that searches for commas and extracts everything between two commas. This way, the parser is independent of the number of digits for the individual message fields. It will even be able to handle empty fields ",,". Beside the commas, a good parser should be able to handle the valid flags correctly. Data are only valid if the valid flag is set to valid. If it's set to invalid, the NMEA parser should reject data output by the receiver. By no means should it forward it to the application.  Starting with Firmware 5.0, it's possible to configure ANTARIS®4 to output LAT & LON with 4 digits etc.
Supports proprietary NMEA messages (PSRF)	Supports proprietary NMEA messages (PUBX)	The NMEA specification does not include input messages. This is why GPS manufacturers introduce proprietary NMEA messages. If PSRF messages have been used with TIM-ST, migrate them to either PUBX or even better to UBX-CFG-xxx messages. The latter is preferred and it's easy since ANTARIS is able to handle to protocols on the same port (4.3).

### Binary Protocol

TIM-ST supports SiRF binary protocol whereas TIM-4x supports UBX protocol. These two protocols are not compatible. It is necessary to migrate the host software to UBX protocol if SiRF binary was used before.

### Antenna and Antenna Supervisor

TIM-ST does not have a built-in antenna supervisor whereas all TIM-4x modules have a built-in short-circuit detection. TIM-ST designs with external active antenna supervisor will not work without minor modifications to the circuitry.

### Power Supply

TIM-4x receivers consume approximately 120mA less current, which is usually not a problem.

	TIM-ST	TIM-4x (ANTARIS®4)	Remarks
Vcc	2.75 – 3.45	2.7 – 3.3V	
Current Consumption	<160mA	Approx 36 – 40mA	TIM-4x current consumption depends on TIM-4x variant
Power Saving Mode	TPM, Push-2-fix	FixNOW	In most cases, it's not necessary to use FixNOW mode due to the much lower current consumption of TIM-4x

**Note:** Make sure the ripple on Vcc is below 50mV.

## Pin-out

The pin-outs of TIM-ST and TIM-4x modules do not differ significantly. *Table 84* compares the modules and highlights the differences to be considered.

Pin	TIM-ST		TIM-4x		Remarks
	Pin Name	Typical Assignment	Pin Name	Typical Assignment	
1	VCC	2.75 – 3.45V	VCC	2.70 – 3.30V	The nominal voltages are identical but the tolerances differ slightly. u-blox recommends using a 3.0V LDO for TIM-4x (see 4.2.1.1)
2	GND	GND	GND	GND	No difference
3	BOOT_INT	NC	BOOT_INT	NC	No difference
4	RXD1	3.0V in	RXD1	1.8 to 5.0V in	No difference
5	TXD1	3.0V out	TXD1	3.0V out	No difference
6	TXD2	3.0V in	TXD2	3.0V out	No difference
7	RXD2	3.0V out	RXD2	1.8 to 5.0V in	No difference
8	AA_SCD_N	Not connected	SCK1/ P17/ GPSMODE5	Not connected	No difference, if Antenna Supervisor is not used.
9	RF_ON	Not connected	EXTINT1/ GPSMODE3	Not connected	No difference, if RF_ON has not been used.
10	GND	Not connected	VDD18OUT	Not connected	Different function on ANTARIS TIM modules. <b>Needs to be redesigned!</b>
11 to 16	GND	GND	GND	GND	No difference
17	RF_IN	RF_IN	RF_IN	RF_IN	No difference
18	GND	GND	GND	GND	No difference
19	V_ANT	3.0V – 5.0V	V_ANT	3.0V - 5.0V	No difference
20	VCC_RF	VCC - 0.1V	VCC_RF	VCC - 0.1V	No difference
21	V_BAT	1.85 – 3.6V	V_BAT	1.50 – 3.6V	Wider voltage range
22	RESET_N	3.0V	RESET_N	1.8V	Different voltage range. No problem as long as this pin is not driven high (see 4.9.2).
23	NU	Not connected	EXTINT0	3.0V I/O, not connected	This pin is an input on TIM-4x, hence no problem
24	NU	Not connected	PCS1_N / GPSMODE2	3.0V I/O, not connected	No difference
25	NU	Not connected	PCS0_N/ GPSMODE6	3.0V I/O, not connected	No difference
26	NU	Not connected	SCK/ NC	3.0V I/O, not connected	No difference
27	AA_OCD	Not connected	AADET_N	3.0V I/O, not connected	No problem if this pin is not used on TIM-ST. If it was used to control the antenna voltage supply, a minor modification is required for TIM-4x designs (see Section 4.3.3.2).
28	AA_CTRL	Not connected	MOSI/ NC	3.0V I/O, not connected	No problem if this pin is not used on TIM-ST. If it was used to control the antenna voltage supply, a minor modification is required for TIM-4x designs (see Section 4.3.3.2).
29	TIMEPULSE	3.0V out	TIMEPULSE	3.0V out	No difference
30	GND	Not connected	PCS3_N/ GPSMODE 12	3.0V I/O, not connected	P29 is an input on TIM-4x, hence no problem

  : Pins to be checked carefully

**Table 84: Pin-out comparison TIM-ST vs. TIM-4x**

# E Mechanical Dimensions/ Pinout

## E.1 LEA Modules

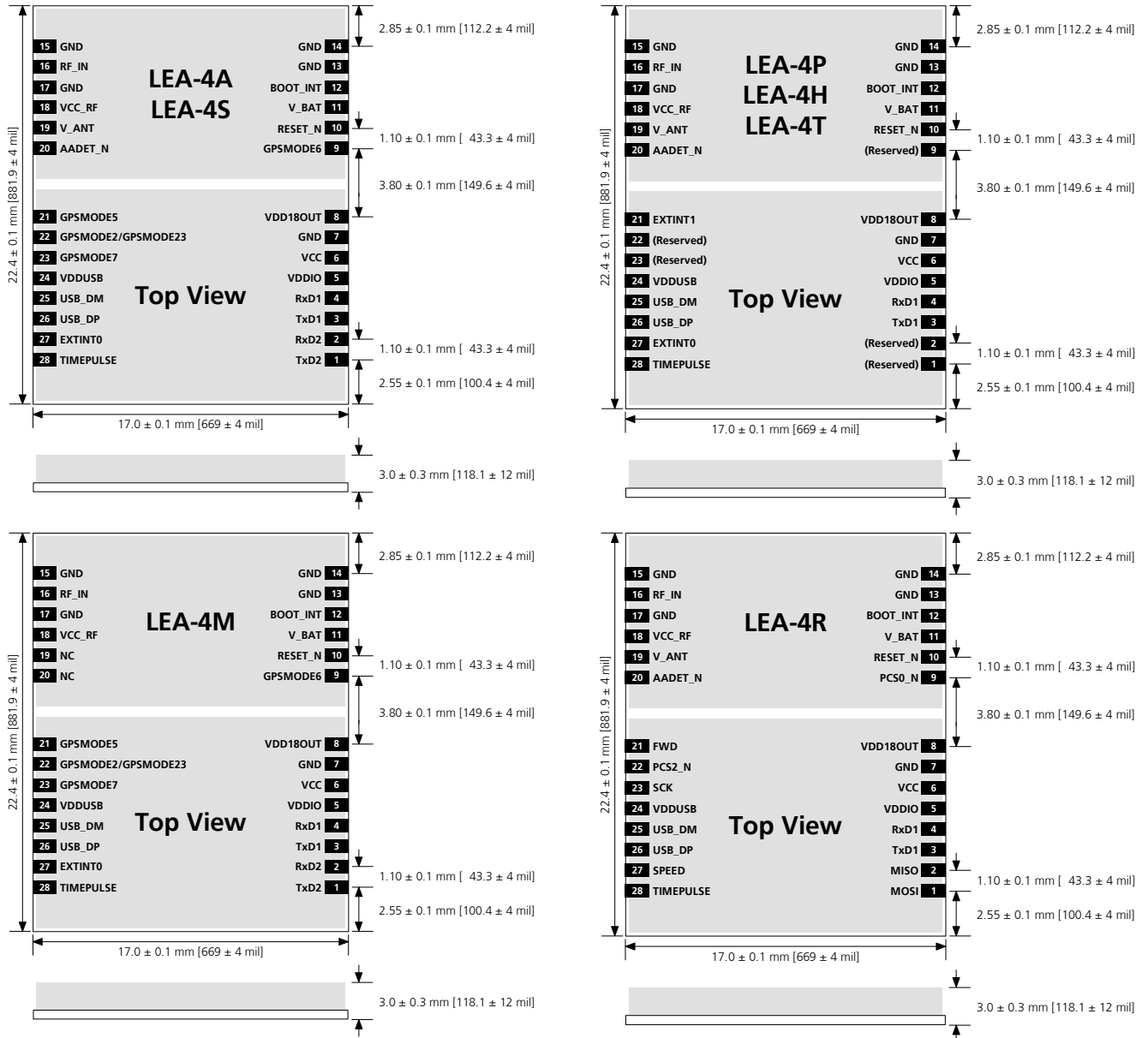

**! Note** Pins designated Reserved should only be used with caution. Pins designated NC may be connected, however, due to forward compatibility this is not recommended.

## E.2 TIM Modules

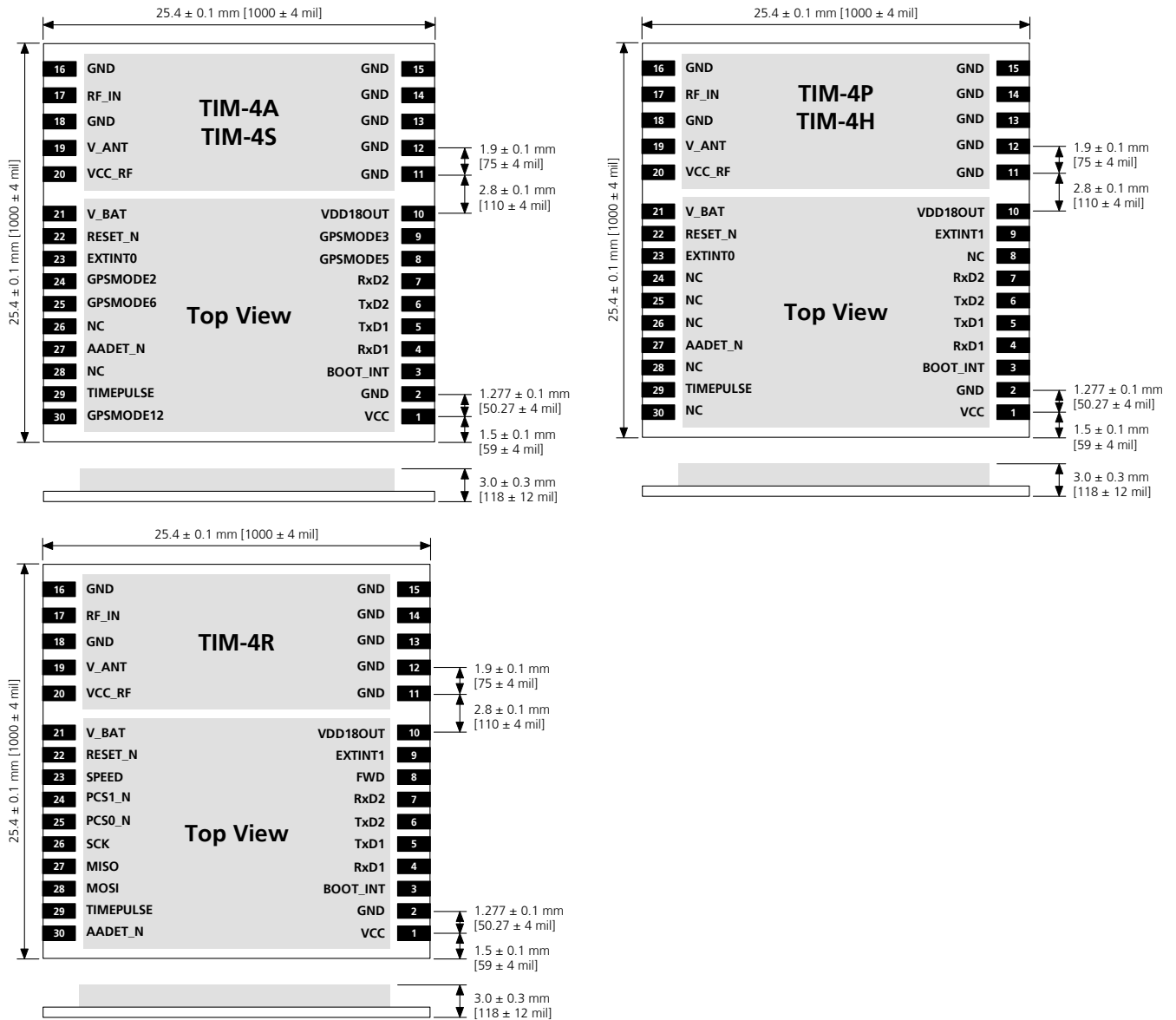

Figure 125: Pin-out TIM-Modules

**! Note** Pins designated Reserved should only be used with caution. Pins designated NC may be connected, however, due to forward compatibility this is not recommended.



### E.3 NEO Modules

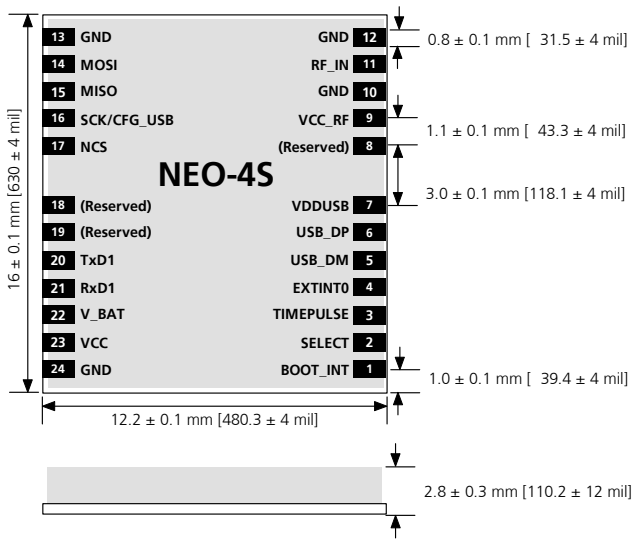

Figure 126: Pin-out NEO-Modules

**! Note** Pins designated Reserved should only be used with caution.

# F Index

## 2

2D Navigation, 99

## A

Accuracy, 30, 63, 71, 72, 100, 101, 110, 144  
Acquisition, 12, 89, 95  
Active Antenna, 42  
AGC, 22, 60  
AGPS, 90  
Aiding, 13, 90  
Aiding Topology, 30, 91  
Almanac Navigation, 96, 99, 144  
Antenna, 42, 144  
Antenna Placement, 21  
Antenna Supervisor, 72, 75, 76, 173  
Assisted GPS, 90  
Auto Sensitivity, 95  
Autobauding, 80, 146  
Automatic Gain Control, 60

## B

Backup Battery, 61, 115  
Backup State, 65, 66  
Baudrate, 146  
Boot Mode, 136  
BOOT\_INT, 60, 122, 136

## C

C/No, 42, 144  
Cleaning, 131  
Clear Configuration, 116  
Coldstart, 12, 89, 121  
Compatibility Mode, 88  
Configuration, 142  
Conformal Coating, 132  
Consideration Mode, 88  
Continuous Tracking Mode, 63, 64, 65  
CPU Only, 65, 66  
CTM, 63, 64, 65

## D

Datum, 96, 144  
Dead Reckoning, 32, 33, 99, 100, 102, 103, 104  
Degraded Navigation, 99  
Design-In Checklist, 43, 51  
DGPS, 30, 88, 96, 105  
Differential GPS, 30, 105  
Dilution of Precision, 14  
DR Enabled Receiver, 36

## E

ECEF, 96  
EGNOS, 31, 105  
Ephemeris, 12  
ESD, 125  
External Interrupt, 122  
EXTINT, 60, 66, 67, 122

## F

Fast Acquisition, 95  
Firmware Update, 135, 136  
FixNOW™, 63, 65  
FLASH, 59, 115, 117  
Footprint, 52  
Full Power State, 65, 66, 69, 71  
FXN, 63, 65

## G

GPS Time, 97, 109, 111, 145  
GPSMODE, 118  
Grounding, 52, 54, 132

## H

Handling, 125  
HDOP, 14  
Helix Antenna, 19  
High Sensitivity, 29, 95  
Hotstart, 13, 89, 90, 121

## I

Input Message, 140

## J

Jamming, 22, 42, 52, 54, 73

## L

Layout, 52  
LEA modules, 37  
Leap Second, 145  
LNA, 17, 59, 73  
Load Configuration, 116  
Low Cost Receiver, 36, 115, 117  
Low Noise Amplifier, 60

## M

Measurement Period, 97  
Message Class, 83  
Message View, 139  
Micro strip, 42, 51, 55, 56  
Migration to ANTARIS®4, 167  
MSAS, 31, 105  
Multi-Port, 79  
Multi-Protocol, 79

## N

Navigation Output, 96  
Navigation Update Rate, 96, 97  
NMEA, 79, 85, 100, 101, 144  
NMEA Parser, 86  
Normal Sensitivity, 95

**O**

OCD, 78  
Odometer, 32, 99, 102, 103  
Open Circuit Detection, 78  
Output Message, 140

**P**

Passive Antenna, 42, 72  
Paste Mask, 53  
Patch Antenna, 17  
PDOP, 14, 100, 101, 144  
Pin Configuration, 118  
Placement, 54  
Position Accuracy Mask, 144  
Position Fix Indicator, 102, 104  
Position upon Request, 66  
Power Saving Modes, 63  
Programmable Receiver, 36, 115, 117

**R**

RAIM, 96, 108  
Receiver Autonomous Integrity Monitoring, 96, 108  
Recording Logfiles, 141  
Reflow Soldering, 129  
Reset, 67, 121  
RESET\_N, 60  
RF\_IN, 54, 72, 73  
Rise time, 110  
RTC, 60, 67  
RTCM, 79, 88

**S**

Satellite Based Augmentation Systems, 185  
Save Configuration, 116  
SAW, 59, 60  
SBAS, 31, 65, 105  
Shielding, 24, 26, 52, 54  
Short Circuit Detection, 78  
Short Circuit Protection, 75  
Sleep State, 65, 66  
Soldering, 129  
Sources of Noise, 22  
SPI, 81

Standard GPS Receivers, 36  
Static Hold Mode, 98  
Status Information, 104  
SuperSense®, 36  
, 93

**T**

TDOP, 110  
Testing, 133  
TIM modules, 38  
*Timemark*, 114  
TIMEPULSE, 60, 100, 109  
Timing Receivers, 36  
TTF, 42, 144  
turn rate sensor, 32, 34, 99, 102, 103

**U**

UBX Protocol, 82  
u-center, 138, 144, 146  
Universal Transverse Mercator, 96  
Update Rate, 96  
USART, 79, 80, 81, 82, 119, 123  
USB Power Mode, 120  
UTC Offset, 145  
UTC Time, 97, 109, 112, 145

**V**

V\_ANT, 73, 74, 75  
Valid Flag, 102, 104  
VCC, 61  
VCC\_RF, 74  
VDOP, 14

**W**

WAAS, 31, 105  
Warmstart, 13, 89, 90, 121  
Wave Soldering, 131  
WGS84, 96, 144

**X**

XTO, 60

# G Lists

## G.1 List of Figures

Figure 1: Basic Signal Processing.....	11
Figure 2: Basic Operation Cycle.....	12
Figure 3: Decision Tree on Startup Mode.....	13
Figure 4: Examples of DOP values.....	15
Figure 5: A multi-path environment.....	15
Figure 6: Patch Antennas, EMTAC Technology Corp.....	16
Figure 7: Quadrifilar Helix Antenna, Sarantel, Ltd.....	17
Figure 8: Typical Radiation Pattern of a Patch Antenna, MuRata, Inc.....	18
Figure 9: Typical Gain and Axial Ratio of a Patch antenna with respect to ground plane size, MuRata, Inc.....	18
Figure 10: Radiation pattern of helix antenna without ground plane, Sarantel, Ltd.....	19
Figure 11: Dependency of center frequency on ground plane dimension for a 25 x 25 mm <sup>2</sup> patch, EMTAC.....	20
Figure 12: Signal and power plane extends should lie within ground plane extends.....	23
Figure 13: Further improvement of reduction of power plane radiation.....	23
Figure 14: Terminating radiation of signal lines.....	24
Figure 15: Impedance of 0805 size SMD capacitors vs. frequency, MuRata.....	24
Figure 16: Temperature dependency of COG/NPO dielectric, AVX.....	25
Figure 17: Temperature dependency of X7R dielectric, AVX.....	25
Figure 18: Temperature dependency of Y5V dielectric, AVX.....	25
Figure 19: Ideal shielding.....	26
Figure 20: MuRata’s NFM21C Feed Through Capacitors.....	27
Figure 21: Two shielded sub-systems, connected by a “poor” ground.....	28
Figure 22: Proper shielding of a sub-system assembly.....	28
Figure 23: Trade-off in Weak Signal GPS.....	29
Figure 24: Improved GPS Coverage with High Sensitivity GPS Receivers.....	29
Figure 25: Aiding Topology.....	30
Figure 26: SBAS-Principle.....	31
Figure 27: Dead Reckoning Block diagram.....	32
Figure 28: Dead Reckoning Principle.....	33
Figure 29: Dead Reckoning Performance Parameters.....	33
Figure 30: Dead Reckoning Blending.....	34
Figure 31: NEO form factor.....	37
Figure 32: LEA form factor.....	37
Figure 33: TIM form factor.....	38
Figure 34: ANTARIS®4.GPS module family.....	39
Figure 35: Compatibility of ANTARIS® TIM receivers.....	41
Figure 36: Compatibility of ANTARIS® LEA receivers.....	41
Figure 37: Passive Antenna Design for LEA-4x Receivers.....	45
Figure 38: Passive Antenna Design for TIM-4x Receivers.....	47
Figure 39: Passive Antenna Design for NEO-4S Receivers.....	49

Figure 40: Recommended footprint.....	52
Figure 41: Solder and paste mask with enlargement showing positioning and cross section of underlying solder paste.....	53
Figure 42: TIM placement.....	54
Figure 43: Recommended layout for TIM-xx .....	55
Figure 44: PCB build-up for Micro strip line. Left: 2-layer PCB, right: 4-layer PCB .....	55
Figure 45: Micro strip on a 2-layer board (Agilent AppCAD Coplanar Waveguide).....	57
Figure 46: Micro strip on a multi layer board (Agilent AppCAD Coplanar Waveguide) .....	57
Figure 47: Recommended layout for connecting the antenna bias voltage for LEA-4M and NEO-4S.....	58
Figure 48: Hardware Block Schematic.....	59
Figure 50: Power supply concept.....	61
Figure 52: Backup Battery and Voltage.....	62
Figure 53: Power Consumption with FixNOW Mode.....	64
Figure 54: On State - Off State .....	65
Figure 55: Simplified FXN state diagram .....	68
Figure 56: FXN without On/Off Time, GPS signal is lost in Full Power State .....	69
Figure 57: FXN with On/Off Time, GPS signal is lost in Full Power State .....	70
Figure 58: FXN with On/Off Time, GPS signal is lost in Full Power State .....	70
Figure 59: FXN With On/Off Time and absolute alignment after a first fix .....	71
Figure 60: Active antenna biasing.....	73
Figure 61: Supplying Antenna bias voltage .....	74
Figure 62: Recommended wiring for active antennas.....	74
Figure 63: External antenna power supply with full antenna supervisor .....	75
Figure 64: State Diagram of Active Antenna Supervisor .....	76
Figure 65: Schematic of open circuit detection .....	77
Figure 66: Connection of "Open Circuit Detection" signal to AADET_N input .....	77
Figure 67: Definition USART data packets.....	80
Figure 68: Self Powered USB Mode Schematic.....	81
Figure 69: Bus Powered USB Mode Schematic.....	81
Figure 70: UBX Protocol Framing .....	82
Figure 71: UBX Checksum range .....	84
Figure 72: NMEA Protocol Framing.....	86
Figure 73: GPS Signal Acquisition .....	89
Figure 74: GPS Signal Acquisition with Aiding .....	90
Figure 75: Aiding Principal.....	91
Figure 78: AssistNow® Online Framework .....	92
Figure 79: AssistNow® Offline Framework.....	92
Figure 80: Direct line-of-sight versus reflected signals .....	93
Figure 81: Receiver Sensitivity (Acquisition).....	95
Figure 84: Examples of a TEC-Map over Europe.....	105
Figure 85: Example of a 1PPS Signal designed with TIMEPULSE .....	109
Figure 86: TIMEPULSE output signal and protocol time message, example for 1 s period and rising edge configuration.....	110
Figure 87: 1PPS TIMEPULSE Output Signal.....	111
Figure 88: 1kHz TIMEPULSE Output Signal .....	111

Figure 89: 60s TIMEPULSE Output Signal.....	112
Figure 90: Timemark example.....	114
Figure 91: Configuration concept.....	115
Figure 92: Saving a configuration section.....	117
Figure 93: ANTARIS®4 GPS Technology Start-Up Procedure.....	118
Figure 94: RESET generation.....	121
Figure 95: Examples for wiring RESET_N.....	122
Figure 96: BOOT_INT, Internal connection.....	122
Figure 97: Reeled ANTARIS®4 GPS Receiver modules.....	124
Figure 98: Dimension of reel for 100 or 250 pieces (dimensions unless otherwise specified in mm).....	124
Figure 99: Dimensions and orientation for ANTARIS®4 GPS Modules on tape.....	125
Figure 100: Applicable MSD Label (See Section 3.1 for baking instructions).....	126
Figure 101: Humidity Indicator Card, good condition.....	127
Figure 102: Recommended soldering profile.....	130
Figure 103: Automatic Test Equipment for Module Tests.....	133
Figure 104: 1-channel GPS simulator.....	134
Figure 105: Screenshot, u-center ANTARIS® Edition, Tools Menu.....	136
Figure 106: Screenshot, u-center Firmware; Update Tool settings for Serial Port Update.....	137
Figure 110: Screenshot, u-center ANTARIS® Edition (u-center AE).....	138
Figure 111: u-Center Message View.....	139
Figure 112: Message Display of an U-center output message.....	140
Figure 113: Message Display of a u-center input message.....	140
Figure 114: u-center player toolbar.....	141
Figure 115: Screenshot, u-center GPS configuration.....	142
Figure 116: Screenshot, u-center getting configuration.....	142
Figure 117: Content of a Configuration File.....	143
Figure 118: Reference layout: Top layer on 2-layer 1.6 mm FR-4 material.....	162
Figure 119: Reference layout: Bottom layer on 2-layer 1.6 mm FR-4 material.....	163
Figure 120: LEA-Smart Antenna (top view/ bottom view).....	163
Figure 121: LEA Smart Antenna Schematic.....	164
Figure 122: Top Layer.....	166
Figure 123: Bottom Layer.....	166
Figure 124: Pin-out LEA-Modules.....	175
Figure 125: Pin-out TIM-Modules.....	176
Figure 126: Pin-out NEO-Modules.....	177

## G.2 List of Tables

Table 1: Optimal antenna placement.....	21
Table 2: PRN of GEO's used for SBAS.....	32
Table 3: Choosing the optimal ANTARIS® GPS module.....	40
Table 4: Active vs. Passive Antenna.....	42
Table 5: Pinnout LEA-4x.....	46

Table 6: Pin-out TIM-4x .....	48
Table 7: Pin-out NEO-4S .....	50
Table 8: Paste Mask Dimensions for TIM-4x, LEA-4x and NEO-4S .....	53
Table 9: Operating Modes .....	63
Table 10: Choosing an operation strategy .....	64
Table 11: Means to reduce Power Consumption in Continuous Tracking Mode .....	65
Table 12: Overview Power States .....	65
Table 13: Possibilities to wakeup the receiver .....	67
Table 14: FXN mode parameter description .....	67
Table 15: Example settings FXN without On/Off Time .....	69
Table 16: Example settings FXN with On/Off Time .....	71
Table 17: Example settings FXN With On/Off Time and absolute Alignment .....	72
Table 18: Short circuit protection, bill of material .....	75
Table 19: Active Antenna Supervisor, bill of material .....	78
Table 20: Active Antenna Supervisor Message on startup (UBX binary protocol) .....	78
Table 21: Active Antenna Supervisor Message on startup (NMEA protocol) .....	79
Table 22: USART configuration .....	80
Table 23: USB Configuration Parameter .....	81
Table 24: UBX Message Class .....	83
Table 25: Internal Field Number Formats .....	84
Table 26: Aiding messages .....	91
Table 27: Overview GPS Navigation Parameter .....	96
Table 28: Navigation rate parameters .....	97
Table 29: Dynamic Platform Model .....	98
Table 30: Navigation Input Filter parameters (UBX-CFG-NAV2) .....	100
Table 31: Navigation Output Filter parameter .....	100
Table 32: NMEA Valid Flag (0183 Version 2.3) .....	102
Table 33: NMEA Valid Flag (0183 Version 2.2 and smaller) .....	103
Table 34: NMEA Output in case of invalid position fixes (Firmware $\geq$ V3.00) .....	103
Table 35: UBX Valid Flags (Position Fix Indicator) .....	104
Table 36: Status Information in UBX Protocol .....	104
Table 37: Supported SBAS messages .....	106
Table 39: SBAS parameters .....	107
Table 40: TIMEPULSE Parameter description .....	109
Table 41: 1PPS TIMEPULSE Parameter settings .....	111
Table 42: 1kHz TIMEPULSE Parameter settings .....	111
Table 43: 60s UTC aligned Timepulse settings .....	112
Table 44: Time Mode Parameter description .....	113
Table 45: Memory/ Storage Media on .....	115
Table 46: Configuration messages .....	116
Table 47: Available GPSMODE's .....	118
Table 48: Sensitivity Settings with GPSMODE pins (for TIM-4x and LEA-4A) .....	119
Table 49: Sensitivity Settings with GPSMODE pins (for LEA-4S) .....	119

Table 50: Serial I/O configuration with GPSPMODE pins .....	119
Table 51: ROM message set .....	120
Table 52: USB Power Modes.....	120
Table 54: Dimensions for ANTARIS®4 GPS Modules on tape .....	125
Table 55: Buttons description in the U-center Message View .....	139
Table 56: Antenna settings.....	147
Table 57: Antenna settings.....	147
Table 58: Datum default settings.....	147
Table 59: Navigation default settings.....	148
Table 60: NMEA Protocol default settings.....	148
Table 61: Output Rates default settings.....	148
Table 62: Receiver Configuration default settings of LEA-4A, LEA-4P, LEA-4M, TIM-4A and TIM-4P .....	149
Table 63: Receiver Configuration default settings of LEA-4H, TIM-4H and NEO-4S .....	149
Table 64: Receiver Configuration default settings of LEA-4S and TIM-4S .....	149
Table 65: FixNOW™ default settings .....	149
Table 66: SBAS Configuration default settings.....	150
Table 67: Port default settings.....	150
Table 68: USB default settings.....	150
Table 69: UBX output rate default settings .....	151
Table 70: NMEA enabled output msg.....	152
Table 71: UBX default enabled INF msg.....	152
Table 72: NMEA default enabled INF msg.....	152
Table 73: Timemark default settings.....	153
Table 74: Timepulse default settings.....	153
Table 75: Datum .....	160
Table 76: Ellipsoids.....	160
Table 77: Rotation and scale.....	161
Table 78: Bill of Material.....	165
Table 79: Pin-out comparison LEA-LA vs. LEA-4A/4S.....	168
Table 80: Pin-out comparison LEA-LA vs. LEA-4x .....	169
Table 81: Pin-out comparison TIM-Lx vs. TIM-4x .....	170
Table 82: Typical Pin Assignment TIM modules.....	171
Table 83: Typical Pin Assignment LEA modules.....	172
Table 84: Pin-out comparison TIM-ST vs. TIM-4x.....	174



## H Glossary

API	Application Programming Interface
APM	Autonomous Power Management
BBR	Battery backup RAM
CTM	Continuous Tracking Mode, operation Mode of the u-blox GPS receiver technology
ECEF	Earth Centered Earth Fixed
ESD	Electro Static Discharge
FixNOW™	Operation Mode of the u-blox GPS receiver technology, initiates fix.
FXN	FixNOW™, operation Mode of the u-blox GPS receiver technology, initiates PVT fix.
HAE	Height Above WGS84-Ellipsoid
LLA	Latitude, Longitude and Altitude
LNA	Low Noise Amplifier
LOS	Line of sight,
MSL	Height above Mean Sea Level or Orthometric Height
NMEA 0183	ASCII based standard data communication protocol used by GPS receivers.
PUBX	u-blox proprietary extension to the NMEA protocol
PVT	Position, Velocity, Time
SA	Selective Availability
SV	Satellite Vehicle
SBAS	Satellite Based Augmentation Systems
TIM-Lx	Placeholder for all ANTARIS® GPS modules like TIM-LA/ TIM-LC/ TIM-LL/ TIM-LF/ TIM-LP / TIM-LH
UBX	File extension for u-center log file or short form for the UBX protocol
UBX Protocol	A proprietary binary protocol used by the ANTARIS™ GPS technology
UTM	Universal Transverse Mercator
u-center AE	u-center ANTARIS® Edition

## Related Documents

- [1] u-blox' GPS Dictionary, Doc No GPS-X-00001
- [2] GPS Basics, Introduction to the System, Doc No GPS-X-02007
- [3] u-center ANTARIS® Edition – Users Guide, Doc No GPS.SW-02001
- [4] ANTARIS® EvalKit – Users Guide, Doc No GPS.G3-EK-02001
- [5] ANTARIS® Technology Software Development Manual, Doc No GPS.G3-DK-03021
- [6] ANTARIS® GPS Software Customization Kit Datasheet, Doc No GPS.G3-DK-03017
- [7] LEA-4R/TIM-4R System Integration Manual, Doc No GPS.G4-05043
- [8] SCKit Manual, CHM, online help file, Doc No GPS.X-03017 (obsolete)
- [9] ANTARIS® 4 Protocol Specifications – CHM, Doc No GPS.G3-X-03002
- [10] USB Installation for ANTARIS® 4 GPS Receivers, Doc No GPS.G4-CS-05007
- [11] TIM-4A Datasheet, Doc No GPS.G4-MS4-05023
- [12] LEA-4A Datasheet, Doc No GPS.G4-MS4-05017
- [13] TIM-4P Datasheet, Doc No GPS.G4-MS4-05027
- [14] LEA-4P Datasheet, Doc No GPS.G4-MS4-05021
- [15] TIM-4H Datasheet, Doc No GPS.G4-MS4-05025
- [16] TIM-LR Datasheet, Doc No GPS.G3-MS3-04039
- [17] TIM-4S Datasheet, Doc No GPS.G4-MS4-05074
- [18] LEA-4S Datasheet, Doc No GPS.G4-MS4-05072
- [19] LEA-4T Datasheet, Doc No GPS.G4-MS4-05070
- [20] NEO-4S Datasheet, Doc No GPS.G4-MS4-06107
- [21] LEA-4M Datasheet, Doc No GPS.G4-MS4-06108

All these documents are available on our homepage (<http://www.u-blox.com>).

## Contact

For further info, please contact us:

### Headquarters

#### u-blox AG

Zuercherstrasse 68  
CH-8800 Thalwil  
Switzerland

Phone: +41 44 722 74 44  
Fax: +41 44 722 74 47  
E-mail: [info@u-blox.com](mailto:info@u-blox.com)

[www.u-blox.com](http://www.u-blox.com)

### Sales Offices

#### North, Central and South America

##### u-blox America, Inc.

1902 Campus Commons Drive  
Suite 310  
Reston, VA 20191  
USA

Phone: +1 (703) 483 3180  
Fax: +1 (703) 483 3179  
E-mail: [info\\_us@u-blox.com](mailto:info_us@u-blox.com)

##### Regional Office West Coast:

8600 Lemon Ave #1  
La Mesa, CA 91941  
USA

Phone: +1 (619) 741 3011  
Fax: +1 (619) 741 4334  
E-mail: [info\\_us@u-blox.com](mailto:info_us@u-blox.com)

##### Technical Support:

Phone: +1 (703) 483 3185  
E-mail: [support\\_us@u-blox.com](mailto:support_us@u-blox.com)

#### Europe, Middle East, Africa

##### u-blox AG

Zuercherstrasse 68  
CH-8800 Thalwil  
Switzerland

Phone: +41 44 722 74 77  
Fax: +41 44 722 74 47  
E-mail: [info@u-blox.com](mailto:info@u-blox.com)

##### Technical Support:

Phone: +41 44 722 74 74  
E-mail: [support@u-blox.com](mailto:support@u-blox.com)

#### Asia, Australia, Pacific

##### u-blox Singapore Pte. Ltd.

435 Orchard Road  
#19-02, Wisma Atria,  
Singapore 238877

Phone: +65 6734 3811  
Fax: +65 6736 1533  
E-mail: [info\\_ap@u-blox.com](mailto:info_ap@u-blox.com)  
Support: [support\\_ap@u-blox.com](mailto:support_ap@u-blox.com)

##### Regional Office China:

Room 716-718  
No. 65 Fuxing Road  
Beijing, 100036, China

Phone: +86 10 68 133 545  
Fax: +86 10 68 217 890  
E-mail: [info\\_cn@u-blox.com](mailto:info_cn@u-blox.com)  
Support: [support\\_cn@u-blox.com](mailto:support_cn@u-blox.com)

##### Regional Office Korea:

1258 Ho, Shinhan MetroKhan  
#1115, BisanDong  
DongAn-Ku  
Anyang-si  
KyungKi-do, Korea

Phone: +82 31 383 2584  
Fax: +82 31 386 2584  
E-mail: [info\\_kr@u-blox.com](mailto:info_kr@u-blox.com)  
Support: [support\\_kr@u-blox.com](mailto:support_kr@u-blox.com)

##### Regional Office Taiwan:

Room 305  
3F, #181, ZouTze Street  
Neihu Dis.  
Taipei, Taiwan

Phone: +886 2 2657 1090  
Fax: +886 2 2657 1097  
E-mail: [info\\_cn@u-blox.com](mailto:info_cn@u-blox.com)  
Support: [support\\_tw@u-blox.com](mailto:support_tw@u-blox.com)