



A10s Datasheet

V1.20

2012.3.27



Revision History

Version	Date	Section/ Page	Decription
V1.00	2011.11.30		Initial version
V1.10	2011.12.30	Pin Description	The GPIOE[0]/[1]/[2] and GPIOG[0]/[1]/[2] are changed for INPUT only.
V1.20	2012.3.27	Pin Package	Revise some description.



Table of Contents

Revision History	1
1. Overview	5
2. Feature.....	6
3. Functional Block Diagram.....	9
4. Pin Assignments.....	10
4.1. Pin Dimension	10
4.2. Pin Map	10
5. Pin Description	13
5.1. Pin Characteristics	13
5.2. Multiplexing Characteristics	38
5.3. Power and Miscellaneous Signals	44
6. Electrical Characteristics.....	48
6.1. Absolute Maximum Ratings.....	48
6.2. Recommended Operating Conditions.....	48
6.3. DC Electrical Characteristics	49
6.4. Oscillator Electrical Characteristics	50
6.5. Power up/down and Reset Specifications.....	50
7. PWM.....	52
7.1. Overview	52
7.2. PWM Signal Description.....	52
8. Async Timer Controller	53
8.1. Overview	53
9. Sync Timer Controller	53
9.1. Overview	53
10. Interrupt Controller.....	54
10.1. Overview	54
10.2. External Interrupt Signal Description.....	54
11. DMA Controller.....	56
11.1. Overview	56
12. SDRAM Controller	57
12.1. Overview	57



12.2.	SDRAM Signal Description.....	57
13.	NAND Flash Controller	61
13.1.	Overview	61
13.2.	NAND Flash Controller Signal Description.....	62
14.	SD3.0 Controller.....	63
14.1.	SD 3.0 Overview	63
14.2.	SD3.0 Controller Signal Description.....	64
15.	Two Wire Interface.....	65
15.1.	Overview	65
15.2.	TWI Controller Signal Description	65
16.	SPI Interface.....	66
16.1.	Overview	66
16.2.	SPI Controller Signal Description	66
17.	UART Interface	67
17.1.	Overview	67
17.2.	UART Controller Signal Description	68
18.	CIR Interface.....	69
18.1.	Overview	69
18.2.	CIR Controller Signal Description	69
19.	USB OTG Controller	70
19.1.	Overview	70
19.2.	USB OTG Controller Signal Description.....	70
20.	USB Host Controller.....	71
20.1.	Overview	71
20.2.	USB Host Controller Signal Description	71
21.	Digital Audio Interface.....	72
21.1.	Overview	72
21.2.	Digital Audio Signal Description	72
22.	Ethernet MAC	74
22.1.	Overview	74
22.2.	EMAC Signal Description.....	74
23.	Transport Stream Controller.....	76
23.1.	Overview	76



23.2.	TS Signal Description	76
24.	Audio Codec.....	77
24.1.	Overview	77
24.2.	Audio Codec Signal Description	77
25.	LRADC.....	79
25.1.	Overview	79
25.2.	LRADC Signal Description.....	79
26.	Touch Panel Controller	80
26.1.	Overview	80
26.2.	Touch Panel Signal Description	80
27.	Keypad Interface	81
27.1.	Overview	81
27.2.	Keypad Signal Description.....	81
28.	TV Encoder	82
28.1.	Overview	82
28.2.	TV-OUT Signal Description.....	82
29.	Camera Sensor Interface	83
29.1.	Overview	83
29.2.	CSI Signal Description.....	83
30.	HDMI Controller.....	84
30.1.	Overview	84
30.2.	HDMI Signal Description	85
31.	Universal LCD/TV Timing Controller	86
31.1.	Overview	86
31.2.	LCD Signal Description	86
32.	Port Controller	87
32.1.	Port Description.....	87
33.	Declaration.....	88



1. Overview

Allwinner Tech has unveiled another competitive ARM Cortex-A8 chip A10s, providing an ideal fit for tablet application with its optimized system performance, lower power consumption and lower total system cost. Based on Android 4.0.4, A10s integrates such functions as Smart Backlight, Audio Codec, RTP, and HDMI to realize stable and reliable performance in tablets and enable better user experience.



2. Feature

CPU

- ARM Cortex-A8 Core
- 32KB I-Cache/32KB D-Cache/256KB L2 Cache
- Using NEON for video, audio, and graphic workloads eases the burden of supporting more dedicated accelerators across the SoC and enables the system to support the standards of tomorrow
- RCT JAVA-Accelerations to optimize just in time(JIT) and dynamic adaptive compilation(DAC), and reduces memory footprint up to three times

GPU

3D Graphic Engine

- Support Open GL ES 1.1/ 2.0 and open VG 1.1

VPU

- Video Decoding (FULL HD)
 - Support all popular video formats, including VP8, AVS, H.264, H.263, VC-1, MPEG-1/2/4
 - Support 1920*1080@60fps in all formats
- Video Encoding
 - Support encoding in H.264 MP format
 - Support 1920*1080@30fps

Display Processing Ability

- Four moveable and size-adjustable layers
- Support multi-format image input
- Support image enhancement processor



- Support Alpha blending / anti-flicker
- Support Hardware cursor
- Support output color correction (luminance / hue / saturation etc)

Display Output Ability

- Support HDMI V1.3/V1.4
- Flexible LCD interface (CPU / Sync RGB)
- Support CVBS

Image Input Ability

- Camera sensor interface (CSI)

Memory

- 32-bit SDRAM controller
 - Support DDR2 SDRAM and DDR3 SDRAM up to 533MHz
 - Memory Capacity up to 16 G-bits
- 8-bit NAND Flash Controller with 4 CE and 2RB signals
 - Support SLC/MLC/TLC/DDR NAND
 - 64-bit ECC

Peripherals

- One USB 2.0 OTG controller for general application and one USB EHCI/OHCI controller for host application
- Three high-speed memory controllers supporting SD version 3.0 and eMMC version 4.3
- One UART with TX/RX and three UARTs with RTS/CTS
- Three SPI controllers
- Three Two-Wire Interfaces
- Key Matrix (8x8) with internal debounce filter



- IR controller supporting CIR remoter
- One embedded TS SPI/ SSI for DTV application
- One 10/100Mbps Ethernet MAC
- 2-Ch 6-bit LRADC for line control
- Internal 4-wire touch panel controller with pressure sensor and 2-point touch
- I2S/PCM controller for 2-Ch output
- Internal 24-bit Audio Codec for 2-Ch headphone, 2-Ch microphone, and stereo FM input
- 2-Ch PWM controller

System

- 8-Ch normal DMA and 8-Ch dedicated DMA
- Internal 48K SRAM on chip
- 6 asynchronous timers, 2 synchronic timers, a watchdog, and 2 AVS counters

Security

- Security System
- Support DES/3DES/AES encryption and decryption.
- Support SHA-1, MD5 message digest
- Support 160-bit hardware PRNG with 192-bit seed
- 128-bit EFUSE chip ID

Package

- TFBGA336package

3. Functional Block Diagram

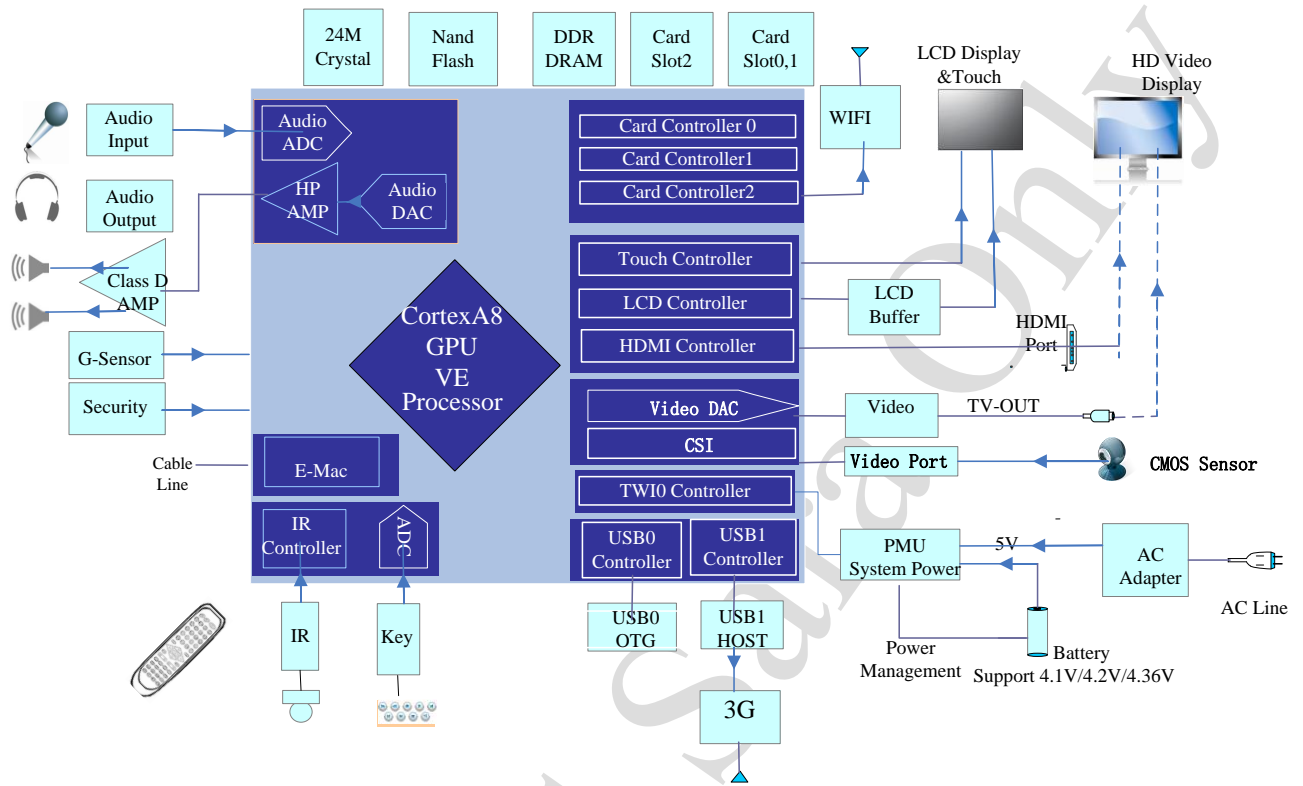

Figure3. A10s Block Diagram

4. Pin Assignments

4.1. Pin Dimension

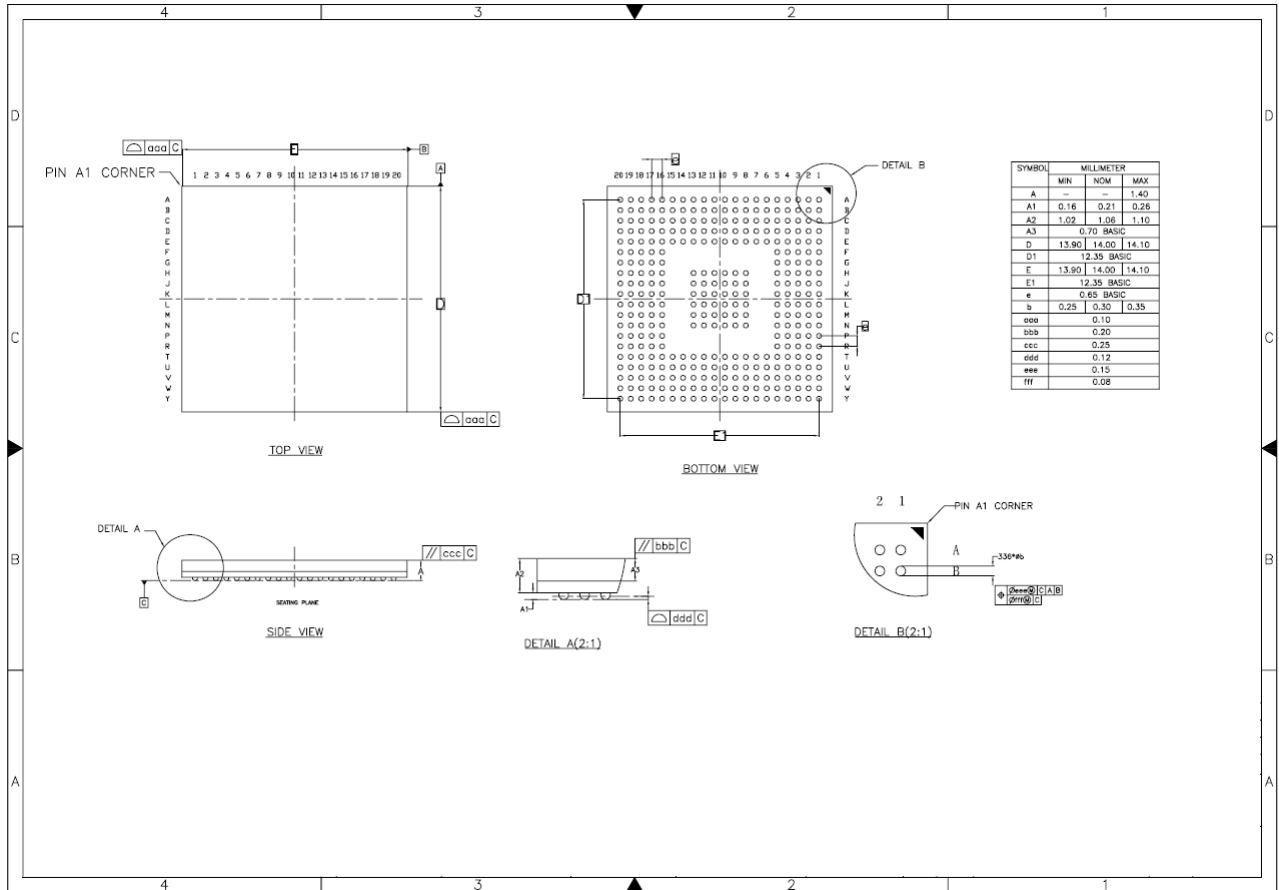

Figure 4-1 A10s TFBGA336 Package Dimension

4.2. Pin Map

The following pin maps show the top view of the 336-pin TFBGA package pin assignments in four quadrants (A, B, C, D).

QuadrantA	QuadrantB
QuadrantC	QuadrantD



	1	2	3	4	5	6	7	8	9	10
A	PC6	PC7	PC9	PC12	PC16	PC18	PB17	RESET_N	BOOTS_N	PG1
B	PC5	PC4	PC8	PC11	PC15	PC17	PC19	PB18	NMI_N	PG0
C	PC3	PC2	PC1	PC10	PC14	PA1	PA3	PA5	PA7	PA9
D	PC0	PB5	PB10	TEST	PC13	PA0	PA2	PA4	PA6	PA8
E	PB6	PB7	PB11	PB12	VCC	VDD_CPU	VDD_CPU	VDD_CPU	VDD_CPU	VDD_CPU
F	PB8	PB9	PB13	PB14	VCC					
G	PG9	PG10	PB19	PB20	VDD_EFUSE					
H	PG11	PG12	PG13	VDD_CORE	VDD_CORE			GND	GND	GND
J	SDQ6	SDQ2	SDQ4	V12_DLL	V12_DLL			GND	GND	GND
K	SDQ0	SDQ11	SZQ	GND_DLL	GND_DLL			GND	GND	GND

Figure 4-2 TFBGA336 Pin Map-Top View [Quadrant A]

	11	12	13	14	15	16	17	18	19	20	
	PG3	PG5	PG7	PB3	PD3	PD7	PD10	PD13	PD14	PD15	A
	PG2	PG4	PG6	PG8	PD2	PD6	PD9	PD12	PD16	PD17	B
	PA13	PA11	PA15	PA17	PD1	PD5	PD8	PD11	PE11	PE10	C
	PA10	PA14	PA12	PA16	PD0	PD4	PD18	PD19	PE9	PE8	D
	VDD_CPU	VDD_CPU	VDD_CPU	VDD_CPU	VDD_CORE	VDD_CORE	PD20	PD21	PE7	PE6	E
						VDD_CORE	PD22	PD23	PE5	PE4	F
						VCC	PD24	PD25	PE3	PE2	G
	GND	GND	GND			VCC	PD26	PD27	PE1	PE0	H
	GND	GND	GND			VCC	PF5	PF4	PB16	PB15	J
	GND	GND	GND			VCC	PF3	PF2	PB4	PB2	K

Figure 4-3 TFBGA336 Pin Map-Top View [Quadrant B]

L	SDQ13	SDQ15	SCKE0	SVREF0	GND_DRAM			
M	SDQ9	SDQM1	SA10	SODT1	VCC_DRAM			
						GND	GND	GND
						GND	GND	GND



N	SDQS0	SDQS0_N	SBA1	SCS1	VCC_DRAM					GND	GND	GND
P	SDQM0	SDQS1	SA4	SA12	GND_DRAM							
R	SDQS1_N	SDQ12	SA6	SA1	GND_DRAM							
T	SDQ8	SDQ14	SA8	SA11	VCC_DRAM	VCC_DRAM	GND_DRAM	GND_DRAM	VCC_DRAM	VCC_DRAM		
U	SDQ10	SDQ1	SA14	SRAS	CKE1	SBA0	SA3	SA2	SA13	SRST		
V	SDQ3	SDQ7	SWE	SCAS	SCS0	SBA2	SA0	SA5	SA9	SA7		
W	SDQ5	SCK	SDQ22	SDQ16	SDQ29	SDQ25	SDQS2	SDQM2	SDQS3	SDQ28		
Y	SCK_N	SDQ20	SDQ18	SDQ27	SDQ31	SDQM3	SDQS2_N	SDQ24	SDQS3_N	SDQ26		
	1	2	3	4	5	6	7	8	9	10		

Figure 4-4 TFBGA336 Pin Map-Top View [Quadrant C]

GND	GND	GND			VCC	PF1	PF0	PB1	PB0	L
GND	GND	GND			VDD_CORE	VDD_CORE	TVOUT	JTAG1_N	JTAG0_N	M
GND	GND	GND			GND_USB	UDP1	UDM1	HTX2N	HTX2P	N
					V33_USB	UDP0	UDM0	HTX1N	HTX1P	P
					V33_HDMI	HCEC	HSCL	HTX0N	HTX0P	R
VCC_DRAM	GND_DRAM	VDD_CORE	V33_HP	AVCC	V33_PLL	HHPD	HSDA	HTXCN	HTXCP	T
SVREF1	GND_DRAM	VDD_CORE	HPBP	GND_HP	AGND	LINEINL	HVREG1	HVREG2	X24MIN	U
SODT0	SDQ19	HPCOMFB	VRA2	VRA1	FMINR	PLLTEST	LINEINR	GND	X24MOUT	V
SDQ30	SDQ21	HPCOM	VRP	MICIN2	FMINL	MIC1OUTP	MIC1OUTN	TPY2	TPY1	W
SDQ17	SDQ23	HPL	HPR	MICIN1	VMIC	LRADC0	LRADC1	TPX2	TPX1	Y
11	12	13	14	15	16	17	18	19	20	

Figure 4-5 TFBGA336 Pin Map-Top View [Quadrant D]



5. Pin Description

5.1. Pin Characteristics

1. **BALL#:** Ball numbers on the bottom side associated with each signals on the bottom.
2. **Pin Name:** Names of signals multiplexed on each ball (also notice that the name of the pin is the signal name in function 0).

3. **Function:** Multiplexing function number.

Function 0 is the the default function, but is not necessarily the primary mode.

Functions 1 to 7 are possible modes for alternate functions.
4. **Type:** signal direction
 - I = Input
 - O = Output
 - I/O = Input/Output
 - A = Analog
 - AIO = Analog Input/Output
 - PWR = Power
 - GND = Ground
5. **Pin Reset State:** The state of the terminal at reset (power up).
 - 0: The buffer drives VOL(pull down/pull up resistor not activated)
 - 0 (PD): The buffer drives V_{OL} with an active pull down resistor.
 - 1: The buffer drives VOH (pull down/pull up resistor not activated).
 - 1 (PU): The buffer drives V_{OH} with an active pull up resistor.
 - Z: High-impedance
 - L: High-impedance with an active pull down resistor.
 - H: High-impedance with an active pull up resistor.
6. **Pull Up/Down:** Denotes the presence of an internal pull up or pull down resistor. Pull up and pull down resistor can be enabled or disabled via software.



7. **Buffer Strength:** Drive strength of the associated output buffer.

Ball	Pin Name	Function	Type	Reset State	Pull Up/Down	Buffer Strength
K1	SDQ0	0/1	I/O			
	DDR2_D6	2				
	DDR3_D0	3				
U2	SDQ1	0/1	I/O			
	DDR2_D7	2				
	DDR3_D1	3				
J2	SDQ2	0/1	I/O			
	DDR2_D1	2				
	DDR3_D2	3				
V1	SDQ3	0/1	I/O			
	DDR2_D0	2				
	DDR3_D3	3				
J3	SDQ4	0/1	I/O			
	DDR2_D4	2				
	DDR3_D4	3				
W1	SDQ5	0/1	I/O			
	DDR2_D5	2				
	DDR3_D5	3				
J1	SDQ6	0/1	I/O			
	DDR2_D3	2				
	DDR3_D6	3				
V2	SDQ7	0/1	I/O			
	DDR2_D2	2				
	DDR3_D7	3				
T1	SDQ8	0/1	I/O			



	DDR2_D8	2				
	DDR3_D8	3				
M1	SDQ9	0/1	I/O			
	DDR2_D11	2				
	DDR3_D9	3				
U1	SDQ10	0/1	I/O			
	DDR2_D13	2				
	DDR3_D10	3				
K2	SDQ11	0/1	I/O			
	DDR2_D12	2				
	DDR3_D11	3				
R2	SDQ12	0/1	I/O			
	DDR2_D15	2				
	DDR3_D12	3				
L1	SDQ13	0/1	I/O			
	DDR2_D9	2				
	DDR3_D13	3				
T2	SDQ14	0/1	I/O			
	DDR2_D10	2				
	DDR3_D14	3				
L2	SDQ15	0/1	I/O			
	DDR2_D14	2				
	DDR3_D15	3				
W4	SDQ16	0/1	I/O			
	DDR2_D22	2				
Y11	SDQ17	0/1	I/O			
	DDR2_D23	2				
Y3	SDQ18	0/1	I/O			



	DDR2_D17	2				
V12	SDQ19	0/1	I/O			
	DDR2_D16	2				
Y2	SDQ20	0/1	I/O			
	DDR2_D20	2				
W12	SDQ21	0/1	I/O			
	DDR2_D21	2				
W2	SDQ22	0/1	I/O			
	DDR2_D19	2				
Y12	SDQ23	0/1	I/O			
	DDR2_D18	2				
Y8	SDQ24	0/1	I/O			
	DDR2_D24	2				
W6	SDQ25	0/1	I/O			
	DDR2_D27	2				
Y10	SDQ26	0/1	I/O			
	DDR2_D29	2				
Y4	SDQ27	0/1	I/O			
	DDR2_D28	2				
W10	SDQ28	0/1	I/O			
	DDR2_D31	2				
W5	SDQ29	0/1	I/O			
	DDR2_D25	2				
W11	SDQ30	0/1	I/O			
	DDR2_D26	2				
Y5	SDQ31	0/1	I/O			
	DDR2_D30	2				
N1	SDQS0	0/1	I/O			



	DDR2_DQS0	2				
	DDR3_DQS0	3				
P2	SDQS1	0/1	I/O			
	DDR2_DQS1	2				
	DDR3_DQS1	3				
W7	SDQS2	0/1	I/O			
	DDR2_DQS2	2				
W9	SDQS3	0/1	I/O			
	DDR2_DQS3	2				
N2	SDQS0#	0/1	I/O			
	DDR2_DQS0#	2				
	DDR3_DQS0#	3				
R1	SDQS1#	0/1	I/O			
	DDR2_DQS1#	2				
	DDR3_DQS1#	3				
Y7	SDQS2#	0/1	I/O			
	DDR2_DQS2#	2				
Y9	SDQS3#	0/1	I/O			
	DDR2_DQS3#	2				
V7	SA0	0/1	O			
	DDR2_BA1	2				
R4	SA1	0/1	O			
	DDR2_A2	2				
U8	SA2	0/1	O			
	DDR2_A1	2				
U7	SA3	0/1	O			
	DDR2_BA0	2				
P3	SA4	0/1	O			



	DDR2_A0	2				
V8	SA5	0/1	O			
	DDR2_A10	2				
R3	SA6	0/1	O			
	DDR2_A4	2				
V10	SA7	0/1	O			
	DDR2_A7	2				
T3	SA8	0/1	O			
	DDR2_A6	2				
V9	SA9	0/1	O			
	DDR2_A3	2				
M3	SA10	0/1	O			
	DDR2_RAS	2				
	DDR3_A10	3				
T4	SA11	0/1	O			
	DDR2_A8	2				
P4	SA12	0/1	O			
	DDR2_CAS	2				
	DDR3_A12	3				
U9	SA13	0/1	O			
	DDR2_A5	2				
U3	SA14	0/1	O			
	DDR2_A14	2				
P1	SDQM0	0/1	O			
	DDR2_DM0	2				
	DDR3_DM0	3				
M2	SDQM1	0/1	O			
	DDR2_DM1	2				



	DDR3_DM1	3				
W8	SDQM2	0/1	O			
	DDR2_DM2	2				
Y6	SDQM3	0/1	O			
	DDR2_DM3	2				
W2	SCK	0/1	O			
	DDR2_CK	2				
	DDR3_CK	3				
Y1	SCK#	0/1	O			
	DDR2_CK#	2				
	DDR3_CK#	3				
L3	SCKE0	0/1	O			
	DDR2_ODT0	2				
	DDR3_CKE0	3				
U5	SCKE1	0/1	O			
	DDR2_CKE1	2				
U6	SBA0	0/1	O			
	DDR2_BA2	2				
N3	SBA1	0/1	O			
	DDR2_CS0	2				
	DDR3_BA1	3				
V6	SBA2	0/1	O			
	DDR2_WE	2				
V5	SCS0	0/1	O			
	DDR3_CS0	2				
N4	SCS1	0/1	O			
	DDR2_CS1	2				
	DDR3_CS1	3				



V11	SODT0	0/1	O			
	DDR2_A12	2				
M4	SODT1	0/1	O			
	DDR2_ODT1	2				
	DDR3_ODT1	3				
U4	SRAS	0/1	O			
	DDR2_A11	2				
V4	SCAS	0/1	O			
	DDR2_A13	2				
V3	SWE	0/1	O			
	DDR2_CKE0	2				
U10	SRST	0/1	O			
	DDR2_A9	2				
K3	SZQ		A			
L4	SVREF0		P			
U11	SVREF1		P			
J4/J5	VDD_DLL		P			
K4/K5	GND_DLL		P			
D6	PA0	0/1	I/O			
	ERXD3	2				
	TS_CLK	3				
	KP_IN0	5				
C6	PA1	0/1	I/O			
	ERXD2	2				
	TS_ERR	3				
	KP_IN1	5				
D7	PA2	0/1	I/O			
	ERXD1	2				



	TS_SYNC	3				
	KP_IN2	5				
C7	PA3	0/1	I/O			
	ERXD0	2				
	TS_DVLD	3				
	KP_IN3	5				
D8	PA4	0/1	I/O			
	ETXD3	2				
	TS_DO	3				
	KP_IN4	5				
C8	PA5	0/1	I/O			
	ETXD2	2				
	TS_D1	3				
	KP_IN5	5				
D9	PA6	0/1	I/O			
	ETXD1	2				
	TS_D2	3				
	KP_IN6	5				
C9	PA7	0/1	I/O			
	ETXD0	2				
	TS_D3	3				
	KP_IN7	5				
D10	PA8	0/1	I/O			
	ERXCK	2				
	TS_D4	3				
	KP_OUT0	5				
C10	PA9	0/1	I/O			
	ERXERR	2				



	TS_D5	3				
	KP_OUT1	5				
D11	PA10	0/1	I/O			
	ERXDV	2				
	TS_D6	3				
	KP_OUT2	5				
C12	PA11	0/1	I/O			
	EMDC	2				
	TS_D7	3				
	KP_OUT3	5				
D13	PA12	0/1	I/O			
	EMDIO	2				
	UART1_TX	3				
	KP_OUT4	5				
C11	PA13	0/1	I/O			
	ETXEN	2				
	UART1_RX	3				
	KP_OUT5	5				
D12	PA14	0/1	I/O			
	ETXCK	2				
	UART1_CTS	3				
	UART3_TX	4				
	KP_OUT6	5				
C13	PA15	0/1	I/O			
	ECRS	2				
	UART1_RTS	3				
	UART3_RX	4				
	KP_OUT7	5				



D14	PA16	0/1	I/O			
	ECOL	2				
	UART2_TX	3				
C14	PA17	0/1	I/O			
	ETXERR	2				
	UART2_RX	3				
	EINT31	6				
L20	PB0	0/1	I/O			
	TWI0_SCK	2				
L19	PB1	0/1	I/O			
	TWI0_SDA	2				
K20	PB2	0/1	I/O			
	PWM0	2				
	/	3				
	EINT16	6				
A14	PB3	0/1	I/O			
	IR_TX	2				
	EINT17	6				
K19	PB4	0/1	I/O			
	IR_RX	2				
	EINT18	6				
D2	PB5	0/1	I/O			
	I2S_MCLK	2				
	EINT19	6				
E1	PB6	0/1	I/O			
	I2S_BCLK	2				
	EINT20	6				
E2	PB7	0/1	I/O			



	I2S_LRCK	2				
	EINT21	6				
F1	PB8	0/1	I/O			
	I2S_DO	2				
	EINT22	6				
F2	PB9	0/1	I/O			
	I2S_DI	2				
	/	3				
	EINT23	6				
D3	PB10	0/1	I/O			
	SPI2_CS1	2				
	/	3				
	EINT24	6				
E3	PB11	0/1	I/O			
	SPI2_CS0	2				
	JTAG_MS0	3				
	EINT25	6				
E4	PB12	0/1	I/O			
	SPI2_CLK	2				
	JTAG_CK0	3				
	EINT26	6				
F3	PB13	0/1	I/O			
	SPI2_MOSI	2				
	JTAG_DO0	3				
	EINT27	6				
F4	PB14	0/1	I/O			
	SPI2_MISO	2				
	JTAG_DI0	3				



	EINT28	6				
J20	PB15	0/1	I/O			
	TWI1_SCK	2				
J19	PB16	0/1	I/O			
	TWI1_SDA	2				
A7	PB17	0/1	I/O			
	TWI2_SCK	2				
B8	PB18	0/1	I/O			
	TWI2_SDA	2				
G3	PB19	0/1	I/O			
	UART0_TX	2				
	EINT29	6				
G4	PB20	0/1	I/O			
	UART0_RX	2				
	EINT30	6				
D1	PC0	0/1	I/O			
	NWE	2				
	SPI0_MOSI	3				
C3	PC1	0/1	I/O			
	NALE	2				
	SPI0_MISO	3				
C2	PC2	0/1	I/O			
	NCLE	2				
	SPI0_CLK	3				
C1	PC3	0/1	I/O		Pull-up	
	NCE1	2				
	SPI0_CS0	3				
B2	PC4	0/1	I/O		Pull-up	



	NCE0	2				
B1	PC5	0/1	I/O			
	NRE	2				
A1	PC6	0/1	I/O		Pull-up	
	NRB0	2				
	SDC2_CMD	3				
A2	PC7	0/1	I/O		Pull-up	
	NRB1	2				
	SDC2_CLK	3				
B3	PC8	0/1	I/O			
	NDQ0	2				
	SDC2_D0	3				
A3	PC9	0/1	I/O			
	NDQ1	2				
	SDC2_D1	3				
C4	PC10	0/1	I/O			
	NDQ2	2				
	SDC2_D2	3				
B4	PC11	0/1	I/O			
	NDQ3	2				
	SDC2_D3	3				
A4	PC12	0/1	I/O			
	NDQ4	2				
	SDC2_D4	3				
D5	PC13	0/1	I/O			
	NDQ5	2				
	SDC2_D5	3				
C5	PC14	0/1	I/O			



	NDQ6	2				
	SDC2_D6	3				
B5	PC15	0/1	I/O			
	NDQ7	2				
	SDC2_D7	3				
A5	PC16	0/1	I/O		Pull-down	
	NWP	2				
	UART3_TX	4				
B6	PC17	0/1	I/O		Pull-up	
	NCE2	2				
	UART3_RX	4				
A6	PC18	0/1	I/O		Pull-up	
	NCE3	2				
	UART2_TX	3				
	UART3_CTS	4				
B7	PC19	0/1	I/O			
	NDQS	2				
	UART2_RX	3				
	UART3_RTS	4				
D15	PD0	0/1	I/O			
	LCD_D0	2				
C15	PD1	0/1	I/O			
	LCD_D1	2				
B15	PD2	0/1	I/O			
	LCD_D2	2				
	UART2_TX	3				
A15	PD3	0/1	I/O			
	LCD_D3	2				



	UART2_RX	3				
D16	PD4	0/1	I/O			
	LCD_D4	2				
	UART2_CTS	3				
C16	PD5	0/1	I/O			
	LCD_D5	2				
	UART2_RTS	3				
B16	PD6	0/1	I/O			
	LCD_D6	2				
	ECRS	3				
A16	PD7	0/1	I/O			
	LCD_D7	2				
	ECOL	3				
C17	PD8	0/1	I/O			
	LCD_D8	2				
B17	PD9	0/1	I/O			
	LCD_D9	2				
A17	PD10	0/1	I/O			
	LCD_D10	2				
	ERXDO	3				
C18	PD11	0/1	I/O			
	LCD_D11	2				
	ERXD1	3				
B18	PD12	0/1	I/O			
	LCD_D12	2				
	ERXD2	3				
A18	PD13	0/1	I/O			
	LCD_D13	2				



	ERXD3	3				
A19	PD14	0/1	I/O			
	LCD_D14	2				
	ERXCK	3				
A20	PD15	0/1	I/O			
	LCD_D15	2				
	ERXERR	3				
B19	PD16	0/1	I/O			
	LCD_D16	2				
B20	PD17	0/1	I/O			
	LCD_D17	2				
D17	PD18	0/1	I/O			
	LCD_D18	2				
	ERXDV	3				
D18	PD19	0/1	I/O			
	LCD_D19	2				
	ETXD0	3				
E17	PD20	0/1	I/O			
	LCD_D20	2				
	ETXD1	3				
E18	PD21	0/1	I/O			
	LCD_D21	2				
	ETXD2	3				
F17	PD22	0/1	I/O			
	LCD_D22	2				
	ETXD3	3				
F18	PD23	0/1	I/O			
	LCD_D23	2				



	ETXEN	3				
G17	PD24	0/1	I/O			
	LCD_CLK	2				
	ETXCK	3				
G18	PD25	0/1	I/O			
	LCD_DE	2				
	ETXERR	3				
H17	PD26	0/1	I/O			
	LCD_HSYNC	2				
	EMDC	3				
H18	PD27	0/1	I/O			
	LCD_VSYNC	2				
	EMDIO	3				
H20	PE0	0/1	I/O			
	TS_CLK	2				
	CSI_PCLK	3				
	SPI2_CS0	4				
H19	PE1	0/1	I/O			
	TS_ERR	2				
	CSI_MCLK	3				
	SPI2_CLK	4				
G20	PE2	0/1	I/O			
	TS_SYNC	2				
	CSI_HSYNC	3				
	SPI2_MOSI	4				
G19	PE3	0/1	I/O			
	TS_DVLD	2				
	CSI_VSYNC	3				



	SPI2_MISO	4				
F20	PE4	0/1	I/O			
	TS_D0	2				
	CSI_D0	3				
	SDC2_DO	4				
F19	PE5	0/1	I/O			
	TS_D1	2				
	CSI_D1	3				
	SDC2_D1	4				
E20	PE6	0/1	I/O			
	TS_D2	2				
	CSI_D2	3				
	SDC2_D2	4				
E19	PE7	0/1	I/O			
	TS_D3	2				
	CSI_D3	3				
	SDC2_D3	4				
D20	PE8	0/1	I/O			
	TS_D4	2				
	CSI_D4	3				
	SDC2_CMD	4				
D19	PE9	0/1	I/O			
	TS_D5	2				
	CSI_D5	3				
	SDC2_CLK	4				
C20	PE10	0/1	I/O			
	TS_D6	2				
	CSI_D6	3				



	UART_TX	4				
C19	PE11	0/1	I/O			
	TS_D7	2				
	CSI_D7	3				
	UART_RX	4				
L18	PF0	0/1	I/O			
	SDC0_D1	2				
	JTAG_MS1	4				
L17	PF1	0/1	I/O			
	SDC0_D0	2				
	JTAG_DI1	4				
K18	PF2	0/1	I/O			
	SDC0_CLK	2				
	UART0_TX	4				
K17	PF3	0/1	I/O			
	SDC0_CMD	2				
	JTAG_DO1	4				
J18	PF4	0/1	I/O			
	SDC0_D3	2				
	UART0_RX	4				
J17	PF5	0/1	I/O			
	SDC0_D2	2				
	JTAG_CK1	4				
B10	PG0	0/1	I/O			
	GPS_CLK	2				
	EINT0	6				
A10	PG1	0/1	I/O			
	GPS_SIGN	2				



	EINT1	6				
B11	PG2	0/1	I/O			
	GPS_MAG	2				
	EINT2	6				
A11	PG3	0/1	I/O			
	SDC1_CMD	2				
	/	3				
	UART1_TX	4				
	EINT3	6				
B12	PG4	0/1	I/O			
	SDC1_CLK	2				
	/	3				
	UART1_RX	4				
	EINT4	6				
A12	PG5	0/1	I/O			
	SDC1_D0	2				
	/	3				
	UART1_CTS	4				
	EINT5	6				
B13	PG6	0/1	I/O			
	SDC1_D1	2				
	/	3				
	UART1_RTS	4				
	UART2_RTS	5				
	EINT6	6				
A13	PG7	0/1	I/O			
	SDC1_D2	2				
	/	3				



	UART2_TX	5				
	EINT7	6				
B14	PG8	0/1	I/O			
	SDC1_D3	2				
	/	3				
	UART2_RX	5				
	EINT8	6				
G1	PG9	0/1	I/O			
	SPI1_CS0	2				
	UART3_TX	3				
	EINT9	6				
G2	PG10	0/1	I/O			
	SPI1_CLK	2				
	UART3_RX	3				
	EINT10	6				
H1	PG11	0/1	I/O			
	SPI1_MOSI	2				
	UART3_CTS	3				
	EINT11	6				
H2	PG12	0/1	I/O			
	SPI1_MISO	2				
	UART3_RTS	3				
	EINT12	6				
H3	PG13	0/1	I/O			
	SPI1_CS1	2				
	PWM1	3				
	UART2_CTS	5				
	EINT13	6				



G5	VDD-EFUSE		P			
A9	UBOOT		I		Pull_up	
M20	JTAG_SEL0				Pull_up	
M19	JTAG_SEL1				Pull_up	
D4	TEST				Pull_down	
B9	NMI#				No-pull	
A8	RESET#					
T17	HHPD					
T18	HSDA					
R18	HSCL					
R17	HCEC					
U18	HVREG1					
U19	HVREG2					
T20	HTXCP					
T19	HTXCN					
R20	HTX0P					
R19	HTX0N					
P20	HTX1P					
P19	HTX1N					
N20	HTX2P					
N19	HTX2N					
R16	V33_HDMI					
M18	TVDAC0					
P18	DM0					
P17	DP0					
N18	DM1					
N17	DP1					
P16	V33_USB					



N16	GND_USB					
Y20	X1					
Y19	X2					
W20	Y1					
W19	Y2					
W16	FMINL					
V16	FMINR					
W17	MIC1OUTP					
VW18	MIC1OUTN					
Y16	VMIC					
W15	MINCIN2					
Y15	MINCIN1					
V15	VRA1					
V14	VRA2					
T15	AVCC					
W14	VRP					
U16	AGND					
Y14	HPOUTR					
U15	GND_HP					
W13	HPCOM					
V13	HPCOMFB					
T14	V33_HP					
U14	HPBP					
Y13	HPOUTL					
Y17	LRADC0					
Y18	LRADC1					
U20	X24MIN					
V20	X24MOUT					



V17	PLLTEST					
U17	LINEINL					
V18	LINEINR					
T16	V33_PLL					
E5/F5/G16 /H16/ J16/K16/L 16	VCC(7)					
M5/N5/T5/ T6/ T9/T10/T1 1	VCC_DRAM(7)					
L5/P5/R5/ T7/ T8/T12/U1 2	GND_DRAM(7)					
E6/E7/E8/ E9/E10/ E11/E12/E 13/E14	VDD_CPU(9)					
E15/E16/F 16/H4/H5/ T13/U13/ M16/M17	VDD_CORE(9)					



V19/H8/H 9/H10/H11 / H12/H13/J 8/J9/J10/J1 1/ J12/J13/K8 /K9/K10/K 11/ K12/K13/L GND(37) 8/L9/L10/ L11/L12/L 13/M8/M9/ M10/M11/ M12/M13/ N8/ N9/N10/N 11/N12/N1 3						
--	--	--	--	--	--	--

Table 5-1 Pin Characteristics

5.2. Multiplexing Characteristics

The following tables provide a description of the A10s multiplexing on the TFBGA336 package.

PortA(PA)	Multiplex Function Select					
	Default	Multi1	Multi2	Multi3	Multi4	Multi5
PA0	PA0	ERXD3	TS_CLK		KP_IN0	
PA1	PA1	ERXD2	TS_ERR		KP_IN1	
PA2	PA2	ERXD1	TS_SYNC		KP_IN2	



PA3	PA3	ERXD0	TS_DVLD		KP_IN3	
PA4	PA4	ETXD3	TS_D0		KP_IN4	
PA5	PA5	ETXD2	TS_D1		KP_IN5	
PA6	PA6	ETXD1	TS_D2		KP_IN6	
PA7	PA7	ETXD0	TS_D3		KP_IN7	
PA8	PA8	ERXCK	TS_D4	UART1_DTR	KP_OUT0	
PA9	PA9	ERXERR	TS_D5	UART1_DSR	KP_OUT1	
PA10	PA10	ERXDV	TS_D6	UART1_DCD	KP_OUT2	
PA11	PA11	EMDC	TS_D7	UART1_RING	KP_OUT3	
PA12	PA12	EMDIO	UART1_TX		KP_OUT4	
PA13	PA13	ETXEN	UART1_RX		KP_OUT5	
PA14	PA14	ETXCK	UART1_CTS	UART3_TX	KP_OUT6	
PA15	PA15	ECRS	UART1_RTS	UART3_RX	KP_OUT7	
PA16	PA16	ECOL	UART2_TX			
PA17	PA17	ETXERR	URAT2_RX			EINT31

Table5-2 Port A(PA) Multiplex Function Select

PortB(PB)	Multiplex Function Select					
	Default	Multi1	Multi2	Multi3	Multi4	Multi5
PB0	PB0	TWI0_SCK				
PB1	PB1	TWI0_SDA				
PB2	PB2	PWM0				EINT16
PB3	PB3	IR_TX				EINT17
PB4	PB4	IR_RX				EINT18
PB5	PB5	I2S_MCLK				EINT19
PB6	PB6	I2S_BCLK				EINT20
PB7	PB7	I2S_LRCK				EINT21
PB8	PB8	I2S_DO				EINT22
PB9	PB9	I2S_DI				EINT23



PB10	PB10	SPI2_CS1				EINT24
PB11	PB11	SPI2_CS0	JTAG_MS0			EINT25
PB12	PB12	SPI2_CLK	JTAG_CK0			EINT26
PB13	PB13	SPI2_MOSI	JTAG_DO0			EINT27
PB14	PB14	SPI2_MISO	JTAG_DIO			EINT28
PB15	PB15	TWI1_SCK				
PB16	PB16	TWI1_SDA				
PB17	PB17	TWI2_SCK				
PB18	PB18	TWI2_SDA				
PB19	PB19	UART0_TX				EINT29
PB20	PB20	UART0_RX				EINT30

Table5-3 Port B(PB) Multiplex Function Select Table

PortC(PC)	Multiplex Function Select					
	Default	Multi1	Multi2	Multi3	Multi4	Multi5
PC0	PC0	NWE	SPI0_MOSI			
PC1	PC1	NALE	SPI0_MISO			
PC2	PC2	NCLE	SPI0_CLK			
PC3	PC3	NCE1	SPI0_CS0			
PC4	PC4	NCE0				
PC5	PC5	NRE				
PC6	PC6	NRB0	SDC2_CMD			
PC7	PC7	NRB1	SDC2_CLK			
PC8	PC8	NDQ0	SDC2_D0			
PC9	PC9	NDQ1	SDC2_D1			
PC10	PC10	NDQ2	SDC2_D2			
PC11	PC11	NDQ3	SDC2_D3			
PC12	PC12	NDQ4	SDC2_D4			



PC13	PC13	NDQ5	SDC2_D5			
PC14	PC14	NDQ6	SDC2_D6			
PC15	PC15	NDQ7	SDC2_D7			
PC16	PC16	NWP		UART3_TX		
PC17	PC17	NCE2		UART3_RX		
PC18	PC18	NCE3	UART2_TX	UART3_CTS		
PC19	PC19	NDQS	URAT2_RX	UART3_RTS		

Table5-4 Port C(PC) Multiplex Function Select Table

PortD(PD)	Multiplex Function Select					
	Default	Multi1	Multi2	Multi3	Multi4	Multi5
PD0	PD0	LCD_D0				
PD1	PD1	LCD_D1				
PD2	PD2	LCD_D2	UART2_TX			
PD3	PD3	LCD_D3	UART2_RX			
PD4	PD4	LCD_D4	UART2_CTS			
PD5	PD5	LCD_D5	UART2_RTS			
PD6	PD6	LCD_D6	ECRS			
PD7	PD7	LCD_D7	ECOL			
PD8	PD8	LCD_D8				
PD9	PD9	LCD_D9				
PD10	PD10	LCD_D10	ERXD0			
PD11	PD11	LCD_D11	ERXD1			
PD12	PD12	LCD_D12	ERXD2			
PD13	PD13	LCD_D13	ERXD3			
PD14	PD14	LCD_D14	ERXCK			
PD15	PD15	LCD_D15	ERXERR			
PD16	PD16	LCD_D16				



PD17	PD17	LCD_D17				
PD18	PD18	LCD_D18	ERXDV			
PD19	PD19	LCD_D19	ETXD0			
PD20	PD20	LCD_D20	ETXD1			
PD21	PD21	LCD_D21	ETXD2			
PD22	PD22	LCD_D22	ETXD3			
PD23	PD23	LCD_D23	ETXEN			
PD24	PD24	LCD_CLK	ETXCK			
PD25	PD25	LCD_DE	ETXERR			
PD26	PD26	LCD_HSYNC	EMDC			
PD27	PD27	LCD_VSYNC	EMDIO			

Table5-5 Port D(PD) Multiplex Function Select Table

PortE(PE)	Multiplex Function Select					
	Default	Multi1	Multi2	Multi3	Multi4	Multi5
PE0	PE0	TS_CLK	CSI_PCLK	SPI2_CS0		EINT14
PE1	PE1	TS_ERR	CSI_MCLK	SPI2_CLK		EINT15
PE2	PE2	TS_SYNC	CSI_HSYNC	SPI2_MOSI		
PE3	PE3	TS_DVLD	CSI_VSYNC	SPI2_MISO		
PE4	PE4	TS_D0	CSI_D0	SDC2_D0		
PE5	PE5	TS_D1	CSI_D1	SDC2_D1		
PE6	PE6	TS_D2	CSI_D2	SDC2_D2		
PE7	PE7	TS_D3	CSI_D3	SDC2_D3		
PE8	PE8	TS_D4	CSI_D4	SDC2_CMD		
PE9	PE9	TS_D5	CSI_D5	SDC2_CLK		
PE10	PE10	TS_D6	CSI_D6	UART1_TX		
PE11	PE11	TS_D7	CSI_D7	UART1_RX		

Note: The PE0/PE1/PE2 are for input only.

Table5-6 Port E(PE) Multiplex Function Select Table



PortF(PF)	Multiplex Function Select					
	Default	Multi1	Multi2	Multi3	Multi4	Multi5
PF0	PF0	SDC0_D1		JTAG_MS1		
PF1	PF1	SDC0_D0		JTAG_DI1		
PF2	PF2	SDC0_CLK		UART0_TX		
PF3	PF3	SDC0_CMD		JTAG_DO1		
PF4	PF4	SDC0_D3		UART0_RX		
PF5	PF5	SDC0_D2		JTAG_CK1		

Table5-7 Port F(PF) Multiplex Function Select Table

PortG(PG)	Multiplex Function Select					
	Default	Multi1	Multi2	Multi3	Multi4	Multi5
PG0	PG0	GPS_CLK				EINT0
PG1	PG1	GPS_SIGN				EINT1
PG2	PG2	GPS_MAG				EINT2
PG3	PG3	SDC1_CMD	/	UART1_TX		EINT3
PG4	PG4	SDC1_CLK	/	UART1_RX		EINT4
PG5	PG5	SDC1_D0	/	UART1_CTS		EINT5
PG6	PG6	SDC1_D1	/	UART1_RTS	UART2_RTS	EINT6
PG7	PG7	SDC1_D2	/		UART2_TX	EINT7
PG8	PG8	SDC1_D3	/		URAT2_RX	EINT8
PG9	PG9	SPI1_CS0	UART3_TX			EINT9
PG10	PG10	SPI1_CLK	UART3_RX			EINT10
PG11	PG11	SPI1_MOSI	UART3_CTS			EINT11
PG12	PG12	SPI1_MISO	UART3_RTS			EINT12
PG13	PG13	SPI1_CS1	PWM1		UART2_CTS	EINT13

Note: The PG0/PG1/PG2 are for input only.



Table5-8 Port G(PG) Multiplex Function Select Table

5.3. Power and Miscellaneous Signals

Many signals are available on multiple pins according to the software configuration of the multiplexing options.

1. Signal Name: The signal name
2. Description: Description of the signal
3. Type: Pin type for this specific function:
 - I = Input
 - O = Output
 - Z = High-impedance
 - A = Analog
 - PWR = Power
 - GND = Ground
4. Pin #: Associated ball(s) number

5.3.1. Power Domain Signal Description

Signal Name	Description	Pin Name	Ball#
HDMI			
V33_HDMI	HDMI Power Supply	V33_HDMI	R16
Audio DAC Power			
GND_HP	Headphone Ground	GND_HP	U15
V33_HP	Headphone Power Supply	V33_HP	T14
Audio ADC Power			
VMIC	Microphone ADC Power Supply	VMIC	Y16
USB Power			
V33_USB	USB Power Supply	V33_USB	P16
GND33_USB	USB Ground	GND33_USB	N16
PLL Power			



Signal Name	Description	Pin Name	Ball#
V33_PLL	PLL Power Supply	V33_PLL	T16
Core Power			
VDD	Core Chip Power Supply	VDD(9)	E15/E16/F16/H4/H5/T13/U13/M16/M17
GND	Core Chip Ground	GND(37)	V19/H8/H9/H10/H11/H12/H13/J8/J9/J10/J11/J12/J13/K8/K9/K10/K11/K12/K13/L8/L9/L10/L11/L12/L13/M8/M9/M10/M11/M12/M13/N8/N9/N10/N11/N12/N13
IO Power			
VCC	IO Power Supply	VCC(7)	E5/F5/G16/H16/J16/K16/L16
CPU Power			
VDD_CPU	CPU Power Supply	VDD_CPU(9)	E6/E7/E8/E9/E10/E11/E12/E13/E14
DRAM Power			
VCC_DRAM	DRAM Power Supply	VCC_DRAM (7)	M5/N5/T5/T6/T9/T10/T11
GND_DRAM	DRAM Ground	GND_DRAM (7)	L5/P5/R5/T7/T8/T12/U12
SDRAM Power			
V12_DLL	SDRAM Power Supply	V12_DLL (2)	J4/J5
GND_DLL	SDRAM Ground	GND_DLL(2)	K4/K5



Signal Name	Description	Pin Name	Ball#
Analog Power			
AVCC	Analog Power Supply	AVCC	T15
AGND	Analog Ground	AGND	U16

Table 5-9 Power Domain Signal Description

5.3.2. Miscellaneous Signal Description

Signal Name	Description	Type	Pin Name	Ball#
JTAG Interface				
JTAG_SEL0	JTAG port Select bit0	I	JTAG_SEL0	M20
JTAG_SEL1	JTAG Port Select Bit1	I	JTAG_SEL1	M19
JTAG Port 0				
JTAG_MS0	JTAG Mode Select	I	PB11	E3
JTAG_CK0	JTAG Clock	I	PB12	E4
JTAG_DO0	JTAG test DataOutput	O	PB13	F3
JTAG_DI0	JTAG test Data Input	I	PB14	F4
JTAG Port 1				
JTAG_MS1	JTAG Mode Select	I/O	PF0	L18
JTAG_CK1	JTAG Clock	I/O	PF5	J17
JTAG_DO1	JTAG test DataOutput	I/O	PF3	K17
JTAG_DI1	JTAG test Data Input	I/O	PF1	L17
Clock				
X24MIN	Main 24MHz crystal Input for internal OSC	I	X24MIN	U20
X24MOUT	Main 24MHz crystal Output for internal OSC	O	X24MOUT	V20
Reset				
RESET#	System Reset	I	RESET#	A8
FIQ				
NMI#	External Fast Interrupt Request	I	NMI#	B9



Signal Name	Description	Type	Pin Name	Ball#
Boot				
UBOOT	Boot Mode	I	UBOOT	A9
Test				
TEST	Test Pin (Pull down Internal default)	I	TEST	D4
Others				
VRP	=AVCC=3.0V	A	VRP	W14
VRA1	=1.5V	A	VRA1	V15
VRA2	=0V	A	VRA2	V14

Table 5-10 Miscellaneous Signal Description



6. Electrical Characteristics

6.1. Absolute Maximum Ratings

The absolute maximum ratings (shown in Table 6-1) define limitations for electrical and thermal stresses. These limits prevent permanent damage to the A10s.

Note: Absolute maximum ratings are not operating ranges. Operation at absolute maximum ratings is not guaranteed.

Symbol	Parameter	Min	Typ	Unit	
TS	Storage Temperature	-20	125	℃	
II/O	In/Out current for input and output	/	/	mA	
VESD	ESD stress voltage	HBM(human body model)	/	/	VESD
		CDM(charged device model)	-	-	
VCC	DC Supply Voltage for I/O	2.7	3.3	V	
VDD	DC Supply Voltage for Internal Digital Logic	1.0	1.3	V	
VCC_ANALOG	DC Supply Voltage for Analog Part	2.7	3.3	V	
VCC_DRAM	DC Supply Voltage for DRAM Part	1.3	2.0	V	
VCC_USB	DC Supply Voltage for USB PHY	2.7	3.3	V	
VCC_TV	DC Supply Voltage for TV-OUT DAC	2.7	3.3	V	
VCC_LRADC	DC Supply Voltage for LRADC	3.0	3.0	V	
VCC_HP	DC Supply Voltage for Headphone	2.7	3.3	V	
VDD_PLL	DC Supply Voltage for PLL	1.2	1.3	V	

Table 6-1 Multiplexing Characteristics

6.2. Recommended Operating Conditions

All A10s modules are used under the operating Conditions contained in Table 6-2.



Symbol	Parameter	Min	Typ	Max	Unit
Ta	Operating Temperature[Commercial]	-25	-	+85	℃
	Operating Temperature[Extended]	-40	-	+85	℃
GND	Ground	0	0	0	V
VCC	DC Supply Voltage for I/O	-	3.3	-	V
VDD	DC Supply Voltage for Internal Digital Logic	-	1.2	-	V
VCC_ANALOG	DC Supply Voltage for Analog Part	-	3.0	-	V
VCC_DRAM	DC Supply Voltage for DRAM Part	-	1.5	-	V
VCC_USB	DC Supply Voltage for USB PHY	-	3.3	-	V
VCC_TV	DC Supply Voltage for TV-OUT DAC	-	3.3	-	V

Table 6-2 Recommended Operating Conditions

6.3. DC Electrical Characteristics

Table 6-3 summarizes the DC electrical characteristics of A10s.

Symbol	Parameter	Min	Typ	Max	Unit
VIH	High-level input voltage	2.4	3.0	3.3	V
VIL	Low-level input voltage	0	0.5	1.0	V
VHYS	Hysteresis voltage	/	/	/	mV
IIH	High-level input current	/	/	/	uA
IIL	Low-level input current	/	/	/	uA
VOH	High-level output voltage	3.3	3.3	3.3	V
VOL	Low-level output voltage	0	0	0	V
IOZ	Tri-State Output Leakage Current	/	/	/	uA
CIN	Input capacitance	/	/	/	pF
COUT	Output capacitance	/	/	/	pF

Table 6-3 DC Electrical Characteristics



6.4. Oscillator Electrical Characteristics

The A10s contains a 24.000 MHz oscillator.

The A10s device operation requires the following input clock:

- The 24.000MHz frequency is used to generate the main source clock of the A10s device.

6.4.1. 24MHz Oscillator Characteristics

Table 6-4 lists the 24MHz crystal specifications.

Symbol	Parameter	Min	Typ	Max	Unit
1/(tCPMAIN)	Crystal Oscillator Frequency Range		24.000		MHz
tST	Startup Time	–	–		ms
	Frequency Tolerance at 25 °C	-50	–	+50	ppm
	Oscillation Mode	Fundamental			–
	Maximum change over temperature range	-50	–	+50	ppm
PON	Drive level	–	–	50	uW
CL	Equivalent Load capacitance	–		–	pF
CL1,CL2	Internal Load capacitance(CL1=CL2)	–		–	pF
RS	Series Resistance(ESR)	–		–	Ω
	Duty Cycle	30	50	70	%
CM	Motional capacitance	–	–		pF
CSHUT	Shunt capacitance	–	–		pF
RBIAS	Internal bias resistor				MΩ

Table 6-4 24MHz Oscillator Characteristics

6.5. Power up/down and Reset Specifications

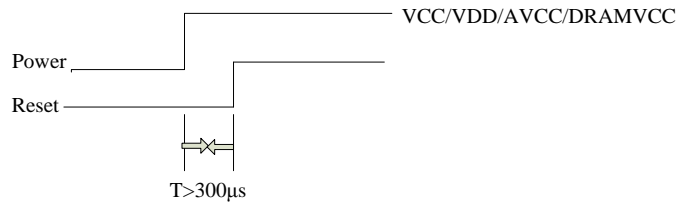

6.5.1. Power-up Sequence

The external voltage regulator and other power-on devices must provide the processor with a specific sequence of power and resets to ensure proper operation. Figure 6-x shows this sequence and is detailed in Table 6-x.

6.5.2. Power-down Sequence

The sequence indicated in Figure 6-x and detailed in Table 6-x is the required timing parameters for power-down.



7. PWM

7.1. Overview

The output of the PWM is a toggling signal whose frequency and duty cycle can be modulated by its programmable registers. Each channel has a dedicated internal 16-bit up counter. If the counter reaches the value stored in the channel period register, it resets. At the beginning of a count period cycle, the PWMOUT is set to activate state and count from 0x0000.

The PWM divider divides the clock (24MHz) by 1-4096 according to the pre-scalar bits in the PWM control register.

In PWM cycle mode, the output will be a square waveform; the frequency is set to the period register. In PWM pulse mode, the output will be a positive pulse or a negative pulse.

7.2. PWM Signal Description

Signal Name	Description	Type	Pin Name	Ball#
PWM0	PWM output for port 0	O	PB2	K20
PWM1	PWM output for port 1	O	PG13	H3

Table 7. PWM Signal Description



8. Async Timer Controller

8.1. Overview

The chip implements 6 timers.

Timer 0/1/2 can take their inputs from the PLL6/6 or OSC24M. They provide the operating system's scheduler interrupt. It is designed to offer maximum accuracy and efficient management, even for systems with long or short response time. They provide 32-bit programmable overflow counter and work in auto-reload mode or no-reload mode.

The watch-dog is used to resume controller operation by generating a general reset or an interrupt request when it is disturbed by malfunctions such as noise and system errors. It features a down counter that allows a watchdog period of up to 16 seconds.

Timer 3 is used for OS to generate a periodic interrupt.

9. Sync Timer Controller

9.1. Overview

The chip implements 2 sync timers for high-speed counter.



10. Interrupt Controller

10.1. Overview

The interrupt controller features:

- Control the nIRQ and FIQ of a RISC Processor
- Ninety-six interrupt sources
- 4-Level Priority Controller
- External Sources of Edge-sensitive or Level-sensitive

It provides handling of up to Ninety-six interrupt sources. Since the 4-level Priority Controller allows users to define the priority of each interrupt source, so higher priority interrupts can be serviced even if a lower priority interrupt is being treated.

10.2. External Interrupt Signal Description

Signal Name	Description	Type	Pin Name	Ball#
EINT0	External Interrupt source 0	I	PG0	B10
EINT1	External Interrupt source 1	I	PG1	A10
EINT2	External Interrupt source 2	I	PG2	B11
EINT3	External Interrupt source 3	I	PG3	A11
EINT4	External Interrupt source 4	I	PG4	B12
EINT5	External Interrupt source 5	I	PG5	A12
EINT6	External Interrupt source 6	I	PG6	B13
EINT7	External Interrupt source 7	I	PG7	A13
EINT8	External Interrupt source 8	I	PG8	B14
EINT9	External Interrupt source 9	I	PG9	G1



Signal Name	Description	Type	Pin Name	Ball#
EINT10	External Interrupt source 10	I	PG10	G2
EINT11	External Interrupt source 11	I	PG11	H1
EINT12	External Interrupt source 12	I	PG12	H2
EINT13	External Interrupt source 13	I	PG13	H3
EINT14	External Interrupt source 14	I	PE0	H20
EINT15	External Interrupt source 15	I	PE1	H19
EINT16	External Interrupt source 16	I	PB2	K20
EINT17	External Interrupt source 17	I	PB3	A14
EINT18	External Interrupt source 18	I	PB4	K19
EINT19	External Interrupt source 19	I	PB5	D2
EINT20	External Interrupt source 20	I	PB6	E1
EINT21	External Interrupt source 21	I	PB7	E2
EINT22	External Interrupt source 22	I	PB8	F1
EINT23	External Interrupt source 23	I	PB9	F2
EINT24	External Interrupt source 24	I	PB10	D3
EINT25	External Interrupt source 25	I	PB11	E3
EINT26	External Interrupt source 26	I	PB12	E4
EINT27	External Interrupt source 27	I	PB13	F3
EINT28	External Interrupt source 28	I	PB14	F4
EINT29	External Interrupt source 29	I	PB19	G3
EINT30	External Interrupt source 30	I	PB20	G4
EINT31	External Interrupt source 31	I	PA17	C14

Table 10. External Interrupt Signal Description



11. DMA Controller

11.1. Overview

There are two kinds of DMA in the chip. One is Normal DMA with 8 channels, and the other is Dedicated DMA with 8 channels.

For normal DMA, only one channel can be active and the sequence is in accordance with the priority level. As for the dedicated DMA, at most 8-channel can be active at the same time if their source or destination does not conflict.



12. SDRAM Controller

12.1. Overview

The SDRAM Controller (DRAMC) provides a simple, flexible, burst-optimized interface to all industry-standard double data rate II (DDR2) ordinary SDRAM and Double data rate III (DDR3) ordinary SDRAM. It supports up to a 16G bits memory address space.

The DRAMC automatically handles memory management, initialization, and refresh operations. It gives the host CPU a simple command interface, hiding details of the required address, page, and burst handling procedures. All memory parameters are runtime-configurable, including timing, memory setting, SDRAM type, and Extended-Mode-Register settings.

The DRAMC includes following features:

- Support DDR2 SDRAM and DDR3 SDRAM
- Support different memory device power voltage of 1.5V and 1.8V
- Support DDR2/3 SDRAM of clock frequency up to DDR1066
- Support memory capacity up to 16G bits (2G Bytes)
- Support 2 chip select signals
- 15 address lines and 3 bank address lines
- Data IO size can up to 32-bit for DDR2 and DDR3 (x8, x16)
- Automatically generate initialization and refresh sequences
- Runtime-configurable parameters setting for application flexibility
- Clock frequency can be chosen for different applications
- Priority of transferring through multiple ports is programmable
- Support random read or write operation

12.2. SDRAM Signal Description



Signal Name	Description	Type	Pin Name	Ball#
SDQ0	SDRAM Data Bus bit0	I/O	SDQ0	K1
SDQ1	SDRAM Data Bus bit1	I/O	SDQ1	U2
SDQ2	SDRAM Data Bus bit2	I/O	SDQ2	J2
SDQ3	SDRAM Data Bus bit3	I/O	SDQ3	V1
SDQ4	SDRAM Data Bus bit4	I/O	SDQ4	J3
SDQ5	SDRAM Data Bus bit5	I/O	SDQ5	W1
SDQ6	SDRAM Data Bus bit6	I/O	SDQ6	J1
SDQ7	SDRAM Data Bus bit7	I/O	SDQ7	V2
SDQ8	SDRAM Data Bus bit8	I/O	SDQ8	T1
SDQ9	SDRAM Data Bus bit9	I/O	SDQ9	M1
SDQ10	SDRAM Data Bus bit10	I/O	SDQ10	U1
SDQ11	SDRAM Data Bus bit11	I/O	SDQ11	K2
SDQ12	SDRAM Data Bus bit12	I/O	SDQ12	R2
SDQ13	SDRAM Data Bus bit13	I/O	SDQ13	L1
SDQ14	SDRAM Data Bus bit14	I/O	SDQ14	T2
SDQ15	SDRAM Data Bus bit15	I/O	SDQ15	L2
SDQ16	SDRAM Data Bus bit16	I/O	SDQ16	W4
SDQ17	SDRAM Data Bus bit17	I/O	SDQ17	Y11
SDQ18	SDRAM Data Bus bit18	I/O	SDQ18	Y3
SDQ19	SDRAM Data Bus bit19	I/O	SDQ19	V12
SDQ20	SDRAM Data Bus bit20	I/O	SDQ20	Y2
SDQ21	SDRAM Data Bus bit21	I/O	SDQ21	W12
SDQ22	SDRAM Data Bus bit22	I/O	SDQ22	W2
SDQ23	SDRAM Data Bus bit23	I/O	SDQ23	Y12
SDQ24	SDRAM Data Bus bit24	I/O	SDQ24	Y8
SDQ25	SDRAM Data Bus bit25	I/O	SDQ25	W6
SDQ26	SDRAM Data Bus bit26	I/O	SDQ26	Y10
SDQ27	SDRAM Data Bus bit27	I/O	SDQ27	Y4



Signal Name	Description	Type	Pin Name	Ball#
SDQ28	SDRAM Data Bus bit28	I/O	SDQ28	W10
SDQ29	SDRAM Data Bus bit29	I/O	SDQ29	W5
SDQ30	SDRAM Data Bus bit30	I/O	SDQ30	W11
SDQ31	SDRAM Data Bus bit31	I/O	SDQ31	Y5
SDQS0	SDRAM Data Strobe 0	I/O	SDQS0	N1
SDQS0#	SDRAM Data Strobe 0 Invert	I/O	SDQS0#	N2
SDQM0	SDRAM Data Mask 0	O	SDQM0	P1
SVREF0	SDRAM Reference Input 0	AI	SVREF0	L4
SDQM1	SDRAM Data Mask 1	O	SDQM1	M2
SDQS1	SDRAM Data Strobe 1	I/O	SDQS1	P2
SDQS1#	SDRAM Data Strobe 1 Invert	I/O	SDQS1#	R1
SDQS2	SDRAM Data Strobe 2	I/O	SDQS2	W7
SDQS2#	SDRAM Data Strobe 2 Invert	I/O	SDQS2#	Y7
SDQM2	SDRAM Data Mask 2	O	SDQM2	W8
SVREF1	SDRAM Reference Input 1	AI	SVREF1	U11
SDQM3	SDRAM Data Mask 3	O	SDQM3	Y6
SDQS3	SDRAM Data Strobe 3	I/O	SDQS3	W9
SDQS3#	SDRAM Data Strobe 3 Invert	I/O	SDQS3#	Y9
SCK#	SDRAM Clock Invert	O	SCK#	Y1
SCK	SDRAM Clock	O	SCK	W2
SCKE0	SDRAM Clock Enable	O	SCKE0	L3
SCKE1	SDRAM Clock Enable	O	SCKE1	U5
SA0	SDRAM Data Address bit0	O	SA0	V7
SA1	SDRAM Data Address bit1	O	SA1	R4
SA2	SDRAM Data Address bit2	O	SA2	U8
SA3	SDRAM Data Address bit3	O	SA3	U7
SA4	SDRAM Data Address bit4	O	SA4	P3
SA5	SDRAM Data Address bit5	O	SA5	V8



Signal Name	Description	Type	Pin Name	Ball#
SA6	SDRAM Data Address bit6	O	SA6	R3
SA7	SDRAM Data Address bit7	O	SA7	V10
SA8	SDRAM Data Address bit8	O	SA8	T3
SA9	SDRAM Data Address bit9	O	SA9	V9
SA10	SDRAM Data Address bit10	O	SA10	M3
SA11	SDRAM Data Address bit11	O	SA11	T4
SA12	SDRAM Data Address bit12	O	SA12	P4
SA13	SDRAM Data Address bit13	O	SA13	U9
SA14	SDRAM Data Address bit14	O	SA14	U3
SWE	SDRAM Write Enable	O	SWE	V3
SCAS	SDRAM Column address strobe	O	SCAS	V4
SRAS	SDRAM Row address strobe	O	SRAS	U4
SCS0	SDRAM Chip Select 0	O	SCS0	V5
SCS1	SDRAM Chip Select 1	O	SCS1	N4
SBA0	SDRAM Bank Address 0	O	SBA0	U6
SBA1	SDRAM Bank Address 1	O	SBA1	N3
SBA2	SDRAM Bank Address 2	O	SBA2	V6
SODT0	SDRAM ODT Control Signal 0	O	SODT0	V11
SODT1	SDRAM ODT Control Signal 1	O	SODT1	M4
SRST	SDRAM Reset	O	SRST	U10
SZQ	SDRAM ZQ calibration	A	SZQ	K3
VDD_DLL	DLL Power Supply	P	VDD_DLL	J4/J5
GND_DLL	DLL Ground	P	GND_DLL	K4/K5

Table 12. SDRAM Signal Description



13. NAND Flash Controller

13.1. Overview

The NFC supports all NAND/MLC flash memory available in the market and new types can be supported by software re-configuration as well. It can support 4 NAND flash with 3.3 V voltage supply. There are 4 separate chip select lines (CE#) to connect up to 4 flash chips with 2 R/B signals.

The On-the-fly error correction code (ECC) is built in NFC to enhance reliability. BCH is implemented to detect and correct up to 64 bits error per 512 or 1024 bytes data. The on chip ECC and parity checking circuitry of NFC frees CPU for other tasks. The ECC function can be disabled by software.

The data can be transferred by DMA or by CPU memory-mapped IO method. The NFC provides automatic timing control to read or write external Flash. The NFC maintains the proper relativity for CLE, CE# and ALE control signal lines. Three kinds of modes are supported for serial read access: Mode 0 is the conventional serial access, Mode 1 for EDO type, and Mode 2 is for extension EDO type. In addition, NFC can monitor the status of R/B# signal line.

Block management and wear leveling management are implemented in software.

The NFC features:

- Support SLC/MLC/TLC flash and EF-NAND memory
- Software configure seed to randomize engine
- Software configure method for adaptability to a variety of system and memory types
- Support 8-bit Data Bus Width
- Support 1024, 2048, 4096, 8192, 16384 bytes size per page
- Support 3.3 V voltage supply Flash
- Up to 4 flash chips which are controlled by NFC_CEx#
- Support Conventional and EDO serial access method for serial reading Flash



- On-the-fly BCH error correction code which correcting up to 64 bits per 512 or 1024 bytes
- Corrected Error bits number information report
- NFC status information is reported by its registers and support interrupt
- One Command FIFO
- Support external DMA for data transfer
- Two 256x32-bit RAM for Pipeline Procession
- Support SDR, DDR and Toggle NAND

13.2. NAND Flash Controller Signal Description

Signal Name	Description	Type
NCE[3:0]	NAND FLASH Chip Select bit	O
NRB[1:0]	NAND FLASH Chip Ready/Busy bit	I
NWE	NAND FLASH Chip Write Enable	O
NRE	NAND FLASH Chip Read Enable	O
NALE	NAND FLASH Chip Address Latch Enable	O
NCLE	NAND FLASH Chip Command Latch Enable	O
NWP	NAND FLASH Chip Write Protect	O
NDQ[7:0]	NAND FLASH Data bit	I/O
NDQS	NAND FLASH Data Strobe	I/O

Table 13. NAND Flash Controller Signal Description



14. SD3.0 Controller

14.1. SD 3.0 Overview

The SD3.0 controller can be configured as a Secure Digital Multimedia Card controller, which simultaneously supports Secure Digital memory (SD Memo), UHS-1 Card, Secure Digital I/O (SDIO), Multimedia Cards (MMC), eMMC Card and Consumer Electronics Advanced Transport Architecture (CE-ATA).

The SD3.0 controller features:

- Support Secure Digital memory protocol commands (up to SD3.0)
- Support Secure Digital I/O protocol commands
- Support Multimedia Card protocol commands (up to MMC4.3)
- Support CE-ATA digital protocol commands
- Support eMMC boot operation and alternative boot operation
- Support Command Completion signal and interrupt to host processor and Command Completion Signal disable feature
- Support one SD (Version 1.0 to 3.0) or MMC (Version 3.3 to 4.3) or CE-ATA device
- Support hardware CRC generation and error detection
- Support programmable baud rate
- Support host pull-up control
- Support SDIO interrupts in 1-bit and 4-bit modes
- Support SDIO suspend and resume operation
- Support SDIO read wait
- Support block size of 1 to 65535 bytes



- Support descriptor-based internal DMA controller
- Internal 16x32-bit (64 bytes total) FIFO for data transfer
- Support 3.3 V IO pad

14.2. SD3.0 Controller Signal Description

SDCx=SDC[2:0]

Signal Name	Description	Type
SDCx_CLK	SDx/SDIOx/MMCx Clock	O
SDCx_CMD	SDx/SDIOx/MMCx Command Line	I/O
SDCx_D	SDx/SDIOx/MMCx Data bit	I/O

Table 14. SD3.0 Controller Signal Description



15. Two Wire Interface

15.1. Overview

This Two Wire Controller is an interface between CPU host and the serial 2-Wire bus, which supports all standard 2-Wire transfer, including Slave and Master. The communication to the 2-Wire bus is carried out on a byte-wise basis using interrupt or polled handshaking. This 2-Wire Controller can be operated in standard mode (100K bps) or fast-mode (up to 400K bps). Multiple Masters and 10-bit addressing Mode are supported for this specified application. General Call Addressing is supported in Slave mode.

The 2-Wire Controller features:

- Software-programmable for Slave or Master
- Support Repeated START signal
- Support Multi-master systems
- Support 10-bit addressing with 2-Wire bus
- Perform arbitration and clock synchronization
- Own address and General Call address detection
- Interrupt on address detection
- Support speed up to 400K bits/s ('fast mode')
- Support operation from a wide range of input clock frequencies

15.2. TWI Controller Signal Description

$TWIX=TWI[2:0]$

Signal Name	Description	Type
$TWIX_SCK$	TWI-BUS Clock for Channel x	I/O
$TWIX_SDA$	TWI-BUS Data for Channel x	I/O

Table 15. TWI Controller Signal Description



16. SPI Interface

16.1. Overview

The SPI is the Serial Peripheral Interface which allows rapid data communication with less software interrupts. The SPI module contains one 8x64 receiver buffer (RXFIFO) and one 8x64 transmit buffer (TXFIFO). It can work in two modes: Master mode and Slave mode.

It features:

- Full-duplex synchronous serial interface
- Configurable Master/Slave
- 8x64 FIFO for data transmit and receive
- Configurable Polarity and phase of the Chip Select (SPI_SS) and SPI Clock (SPI_SCLK)
- Support Dedicated DMA

16.2. SPI Controller Signal Description

SPIx=SPI[2:0]

Signal Name	Description	Type
SPIx_CS	SPIx Chip Select	I/O
SPIx_MOSI	SPIx Master data Out, Slave data In	I/O
SPIx_MISO	SPIx Master data In, Slave data Out	I/O
SPIx_CLK	SPIx Clock	I/O

Table 16. SPI Controller Signal Description



17. UART Interface

17.1. Overview

The UART is used for serial communication with a peripheral, modem (data carrier equipment, DCE) or data set. Data is written from a master (CPU) over the APB bus to the UART and it is converted to serial form and transmitted to the destination device. Serial data is also received by the UART and stored for the master (CPU) to read back.

The UART contains registers to control the character length, baud rate, parity generation/checking, and interrupt generation. Although there is only one interrupt output signal from the UART, there are several prioritized interrupt types responsible for its assertion. Each of the interrupt types can be separately enabled/disabled with the control registers.

The UART has 16450 and 16550 modes of operation, which are compatible with a range of standard software drivers. In 16550 mode, transmit and receive operations are both buffered by FIFOs. In 16450 mode, these FIFOs are disabled.

The UART supports word lengths from five to eight bits, an optional parity bit and 1, 1.5 or 2 stop bits, and is fully programmable by an AMBA APB CPU interface. A 16-bit programmable baud rate generator and an 8-bit scratch register are included, together with separate transmit and receive FIFOs. Eight modem control lines and a diagnostic loop-back mode are provided.

Interrupts can be generated for a range of TX Buffer/FIFO, RX Buffer/FIFO, Modem Status and Line Status conditions.

The UART includes the following features:

- Compatible with industry-standard 16550 UARTs
- 64-Bytes Transmit and receive data FIFOs
- DMA controller interface
- Software/ Hardware Flow Control



- Programmable Transmit Holding Register Empty interrupt
- Interrupt support for FIFOs, Status Change

17.2. UART Controller Signal Description

UARTx=[3:0]

Signal Name	Description	Type
UARTx_TX	UARTx Transmit Data	O
UARTx_RX	UARTx Receive Data	I
UARTx_CTS	UARTx Clear To Send	I
UARTx_RTS	UARTx Request To Send	O
UART1_RING	UARTx Ring Indicator	I
UART1_DTR	UARTx Data Terminal Ready	O
UART1_DSR	UARTx Data Set Ready	I
UART1_DCD	UARTx Data Carrier Detect	I

Table 17. UART Controller Signal Description



18. CIR Interface

18.1. Overview

The CIR features:

- Full physical layer implementation
- Support CIR for remote control or wireless keyboard
- Dual 8x64-bit FIFO for data transfer
- Programmable FIFO thresholds
- Support Interrupt and DMA

CIR receiver is implemented in hardware to save CPU resource. It samples the input signals on the programmable frequency and records these samples into RX FIFO when one CIR signal is found on the air. The CIR receiver uses Run-Length Code (RLC) to encode pulse width, and the encoded data is buffered in a 64 levels and 8-bit width RX FIFO: the MSB bit is used to record the polarity of the receiving CIR signal (The high level is represented as 1 and the low level is represented as 0), and the rest 7 bits are used for the length of RLC. The maximum length is 128. If the duration of one level (high or low) is more than 128, another byte is used. Since there are always some noises in the air, a threshold can be set to filter the noises to reduce system loading and improve system stability.

18.2. CIR Controller Signal Description

Signal Name	Description	Type
IR_TX	CIR Transmit Data	O
IR_RX	CIR Receive Data	I

Table 18. CIR Controller Signal Description



19. USB OTG Controller

19.1. Overview

The USB OTG is dual-role controller supporting Host and device functions. It can also be configured as a Host-only or Device-only controller, full compliant with the USB 2.0 Specification. The USB OTG can support high-speed (HS, 480-Mbps), full-speed (FS, 12-Mbps), and low-speed (LS, 1.5-Mbps) transfers in Host mode, support high-speed (HS, 480-Mbps) and full-speed (FS, 12-Mbps) in Device mode.

The USB2.0 OTG controller (SIE) features:

- 64-Byte Endpoint 0 for Control Transfer
- Support up to 5 User-Configurable Endpoints for Bulk , Isochronous, Control and Interrupt bi-directional transfers
- Support High-Bandwidth Isochronous & Interrupt transfers
- Support point-to-point and point-to-multipoint transfer in both Host and Peripheral mode

19.2. USB OTG Controller Signal Description

Signal Name	Description	Type
UDM0	USB0 OTG DM	AIO
UDP0	USB0 OTG DP	AIO

Table 19. USB OTG Controller Signal Description



20. USB Host Controller

20.1. Overview

USB Host Controller is fully compliant with the USB 2.0 specification, Enhanced Host Controller Interface (EHCI) Specification, Revision 1.0, and the Open Host Controller Interface (OHCI) Specification Release 1.0a. The controller supports high-speed, 480-Mbps transfers (40 times faster than USB 1.1 full-speed mode) using an EHCI Host Controller, as well as full and low speeds through one or more integrated OHCI Host Controllers.

It features:

- Include an internal DMA Controller for data transfer with memory.
- Comply with Enhanced Host Controller Interface (EHCI) Specification, Version 1.0, and the Open Host Controller Interface (OHCI) Specification, Version 1.0a.
- Support High-Speed (HS, 480-Mbps), Full-Speed (FS, 12-Mbps), and Low-Speed (LS, 1.5-Mbps) Device.
- Support only 1 USB Root Port shared between EHCI and OHCI

20.2. USB Host Controller Signal Description

Signal Name	Description	Type
DM1	USB1 HOST DM	AIO
DP1	USB1 HOST DP	AIO

Table 20. USB Host Controller Signal Description



21. Digital Audio Interface

21.1. Overview

The Digital Audio Interface can be configured as I2S interface or PCM interface by software. When configured as I2S interface ,it can support the industry standard format for I2S, left-justified, or right-justified. PCM is a standard method used to digital audio for transmission over digital communication channels. It supports linear 13 or 16-bit linear, or 8-bit u-law or A-law companded sample formats at 8K samples/s and can receive and transmit on any selection of four of the first four slots following PCM_SYNC.

It features:

- I2S or PCM configured by software
- Full-duplex synchronous serial interface
- Configurable Master / Slave Mode operation
- Audio data resolutions of 16, 20, 24
- I2S Audio data sample rate from 8Khz to 192Khz
- I2S Data format for standard I2S, Left Justified and Right Justified
- I2S supports 2 channel output and 2 channel input
- PCM supports linear sample (8-bit or 16-bit), 8-bit u-law and A-law companded sample
- One 128x24-bit FIFO for data transmit, one 64x24-bit FIFO for data receive
- Programmable FIFO thresholds
- Interrupt and DMA Support
- Two 32-bit Counters for AV sync application
- Loopback mode for test

21.2. Digital Audio Signal Description

Signal Name	Description	Type
I2S_MCLK	I2S Main Clock(system clock)	I/O
I2S_BCLK	I2S serial Bit Clock	I/O



I2S_LRCK	I2S Left or Right channel select clock(frame clock)	I/O
I2S_DO	I2S serial Data Output bit	O
I2S_DI	I2S serial Data Input	I

Table 21. Digital Audio Controller Signal Description

For WITS Sara Only



22. Ethernet MAC

22.1. Overview

The Ethernet MAC Controller enables the host to transmit and receive data over Ethernet in compliance to the IEEE 802.3-2002 standard. It supports 10M/100M external PHY with MII interface in both full and half duplex modes, and supports a 16K byte SRAM for continuous data transmission, flow control as well as DA/SA filtering.

The Ethernet MAC Controller (EMAC) features:

- Support 10/100Mbps data rate
- Support full and half duplex operations
- Support IEEE 802.3x flow control for full-duplex operation
- Support back-pressure flow control for half-duplex operation
- Support DA/SA Filtering
- Support Loop back operations
- Provide MII Interface for external Ethernet PHY
- 3K Bytes FIFO for TX
- 13K Bytes FIFO for RX

22.2. EMAC Signal Description

Signal Name	Description	Type
ERXD3	EMAC MII Receive Data Nibble Data Bit3	I
ERXD2	EMAC MII Receive Data Nibble Data Bit2	I
ERXD1	EMAC MII Receive Data Nibble Data Bit1	I
ERXD0	EMAC MII Receive Data Nibble Data Bit0	I
ETXD3	EMAC MII Transmit Data Nibble Data Bit3	O
ETXD2	EMAC MII Transmit Data Nibble Data Bit2	O
ETXD1	EMAC MII Transmit Data Nibble Data Bit1	O
ETXD0	EMAC MII Transmit Data Nibble Data Bit0	O



Signal Name	Description	Type
ERXCK	EMAC MII Receive Clock Input	I
ERXERR	EMAC MII Receive Error	I
ERXDV	EMAC MII Receive Data Valid	I
EMDC	EMAC MII Management Data Clock	O
EMDIO	EMAC MII Management Data Input/Output	I/O
ETXEN	EMAC MII Transmit Enable	O
ETXCK	EMAC MII Transmit Clock Input	I
ECRS	EMAC MII Carrier Sense	I
ECOL	MII Collision Detect	I
ETXERR	EMAC MII Transmit Error	O

Table 22. EMAC Signal Description



23. Transport Stream Controller

23.1. Overview

The transport stream controller is responsible for de-multiplexing and pre-processing the inputting multimedia data defined in ISO/IEC 13818-1. It receives multimedia data stream from SSI (Synchronous Serial Port)/SPI (Synchronous Parallel Port) inputs and de-multiplexes the data into Packets by PID (Packet Identify), and then the Packet will be stored to memory by DMA.

The TS controller can be used for almost all multimedia applications, for example, DVB STB, IPTV, Streaming-media Box, multimedia players, etc.

The Transport Stream Controller features:

- One external Synchronous Parallel Interface (SPI) or one external Synchronous Serial Interface (SSI)
- 32 channels PID filter
- Support Multiple transport stream packet (188, 192, 204) format
- Configurable SPI and SSI timing parameters
- Hardware packet synchronous byte error detection
- Hardware PCR packet detection
- Configurable SPI transport stream generator for streams in DRAM memory
- Support DMA for data transfer

23.2. TS Signal Description

Signal Name	Description	Type
TS_CLK	TS System Clock	I
TS_ERR	TS Error Indicate Signal	I
TS_SYNC	TS Synchronization Control Signal	I
TS_DVLD	TS Valid Signal	I
TS_D[7:0]	TS Input Data Bit	I

Table 23. TS Signal Description



24. Audio Codec

24.1. Overview

The embedded Audio Codec is a high-quality stereo audio codec with headphone amplifier.

It features:

- On-chip 24-bit DAC for play-back
- On-chip 24-bit ADC for recorder
- Support analog/ digital volume control
- Support 48K and 44.1K sample family
- DAC supports 192K and 96K sample
- Support FM/ Line-in/ Microphone recorder
- Stereo headphone amplifier that can be operated in capless headphone mode
- Support Virtual Ground to automatic change to True Ground to protect headphone amplifier and make function work normal mode

24.2. Audio Codec Signal Description

Signal Name	Description	Type
HPL	Headphone Left channel output	O
HPR	Headphone Right channel output	O
HPCOM	Headphone amplifier output	O
HPCOM_FB	Headphone amplifier Feedback	I
HPBP	Headphone Bypass output	O
FMINL	Audio ADC Input for Left Channel of FM Radio	I
FMINR	Audio ADC Input for Right Channel of FM Radio	I
MICIN1	Audio ADC Input for Channel 1 of Microphone	I
MICIN2	Audio ADC Input for Channel 2 of Microphone	I
MIC1OUTP	Micphone Positive Output	O



MIC1OUTN	Micphone Negative Output	O
LINEINL	Audio ADC Input for Left Channel of Line-in	I
LINEINR	Audio ADC Input for Right Channel of Line-in	I

Table 24. Audio Codec Signal Description

For WITS Sara Only



25. LRADC

25.1. Overview

LRADC is 6-bit resolution and can work up to maximum conversion rate of 250Hz.

It features:

- Support APB 32-bit bus width
- Support interrupt
- Support hold key and general key
- Support single key and continue key mode
- 6-bit resolution
- Voltage input range between 0 to 2V
- Sample Rate up to 250Hz

25.2. LRADC Signal Description

Signal Name	Description	Type
LRADC[1:0]	Low Resolution ADC input(6bit)	I

Table 25. LRADC Signal Description



26. Touch Panel Controller

26.1. Overview

The controller is a 4-wire resistive touch screen controller, includes 12-bit resolution A/D converter. Especially, it provides the ability of dual touch detection. The controller through the implementation of the two A/D conversion has been identified by the location of the screen of single touch, in addition to measurable increase in pressure on the touch screen.

It features:

- 12 bit SAR type A/D converter
- 4-wire I/F
- Dual Touch Detect
- Touch-pressure measurement (Support program set threshold)
- Sampling frequency: 2MHz (max)
- Single-ended conversion of touch screen inputs and ratiometric conversion of touch screen inputs
- TACQ up to 262ms
- Median and averaging filter to reduce noise
- Pen down detection, with programmable sensitivity
- Support X, Y change function

26.2. Touch Panel Signal Description

Signal Name	Description	Type
X[2:1]	Touch Panel ADC input	AI
Y[2:1]	Touch Panel ADC input	AI

Table 26. Touch Panel Signal Description



27. Keypad Interface

27.1. Overview

The Keypad Interface is used to connect external keypad devices, which provides up to 8 rows and 8 columns. The events of key press or key release can be detected to the CPU by an interrupt. To prevent switching noises, internal debouncing filter is provided.

The Keypad Interface features:

- Interrupt for key press or key release
- Internal debouncing filter to prevent the switching noises

27.2. Keypad Signal Description

Signal Name	Description	Type
KP_INx [7:0]	Keypad Interface RowX Data	I
KP_OUTx[7:0]	Keypad Interface ColumnX Data	O

Table 27. Keypad Signal Description



28. TV Encoder

28.1. Overview

The TV encoder enables the display of digital information on analog television sets as well as the new generation of standard digital televisions, providing a high quality, flicker-free viewing experience across the key global video standards NTSC and PAL.

28.2. TV-OUT Signal Description

Signal Name	Description	Type
TV_OUT	TV Analog Output	O

Table 28. TV-OUT Signal Description



29. Camera Sensor Interface

29.1. Overview

The CSI features:

- 8 bits input data
- Support CCIR656 protocol for NTSC and PAL
- 3 parallel data paths for image stream parsing
- Support Received data double buffer
- Parsing bayer data into planar R, G, B output to memory
- Parsing interlaced data into planar or MB Y, Cb, Cr output to memory
- Pass raw data direct to memory
- All data transmit timing can be adjusted by software
- Luminance statistical value

29.2. CSI Signal Description

Signal Name	Description	Type
CSI_PCLK	Camera Sensor Pixel Clock	I
CSI_MCLK	Camera Sensor Clock	O
CSI_HSYNC	Camera Sensor Horizontal Synchronization	I
CSI_VSYNC	Camera Sensor Vertical Synchronization	I
CSI_D[7:0]	Camera Sensor Data Bit	I/O

Table 29. Camera sensor Signal Description



30. HDMI Controller

30.1. Overview

Basic Video/Audio Features:

- HDMI V1.4 compliance
- Support up to 165M pixel/second
- Support Max 4K*4K resolution
- Support 480I/576I/480P/576P/720P/1080I/1080P at 24/25/30/50/59.9hz
- Support 24/30/36/48-bit RGB data format, with 2X/4X repeater
- Support up to 8 channel , 24bit PCM(IEC60958)
- Support IEC61937 compress audio formats
- Support 1-bit audio
- Support HD audio (DTS-HD and Dolly MAT, IEC61937 format)
- Hardware Receiver active sense and Hot plug detect
- Interrupts for programmers

DDC Master Features:

- DDC Host Mode operation
- 7-bit addressing
- Arbitration lost and ACK error detection
- Support Slave clock extension
- Support Interrupt/DMA and polling transfer mode
- FIFO flow control by SCL holding
- 16-byte FIFO
- Max 1023-byte data transfer
- Implicit and Explicit offset address transfer
- Support E-DCC read



30.2. HDMI Signal Description

Signal Name	Description	Type
HHPD	HDMI Hot Plug Detection Signal	I/O
HSDA	HDMI Data	I/O
HSCL	HDMI Clock	I/O
HCEC	HDMI Consumer Electronic Control signal	I/O
HTXCP	TMDS Clock (+)	I/O
HTXCN	TMDS Clock (-)	I/O
HTXxP [2:0]	TMDS Data (+)	I/O
HTXxN [2:0]	TMDS Data (-)	I/O

Table 30. HDMI Signal Description



31. Universal LCD/TV Timing Controller

31.1. Overview

TCON in A10s is of high flexibility in timing configuration as well as LCD module compatibility.

31.2. LCD Signal Description

Signal Name	Description	Type
LCD_CLK	LCD RGB Pixel Clock	I/O
LCD_DE	LCD RGB Data Enable	I/O
LCD_HSYNC	LCD RGB Horizontal Synchronization	I/O
LCD_VSYNC	LCD RGB Vertical Synchronization	I/O
LCD_D[23:0]	LCD Pixel Data Bit	I/O

Table 31. LCD Signal Description



32. Port Controller

32.1. Port Description

The chip has 8 ports for multi-functional input/out pins. They are:

- Port A(PA): 18 input/output port
- Port B(PB): 21input/output port
- Port C(PC): 20 input/output port
- Port D(PD): 28 input/output port
- Port E(PE): 12 input/output port
- Port F(PF): 6 input/output port
- Port G(PG): 14 input/output port

These ports can be easily configured by software for various system configurations. 32 external PIO interrupt sources are supported and interrupt mode can be configured by software.



33. Declaration

This A10s datasheet is the original work and copyrighted property of Allwinner Technology (“Allwinner”). Reproduction in whole or in part must obtain the written approval of Allwinner and give clear acknowledgement to the copyright owner.

The information furnished by Allwinner is believed to be accurate and reliable. Allwinner reserves the right to make changes in circuit design and/or specifications at any time without notice. Allwinner does not assume any responsibility and liability for its use. Nor for any infringements of patents or other rights of the third parties which may result from its use. No license is granted by implication or otherwise under any patent or patent rights of Allwinner. This datasheet neither states nor implies warranty of any kind, including fitness for any particular application.