



1A Low Dropout Positive Voltage Regulators

Features

- Maximum dropout of 1.5V at full load current
- Fast transient response
- Output current limiting
- Built-in thermal shutdown
- Available packages: SOT223, TO252, SOT89
- Good noise rejection
- Three-terminal adjustable or fixed 1.5V, 1.8V, 1.9V, 2.5V, 3.3V, 5.0V
- RoHS-compliant, halogen-free

Description

The APE1117 is a low dropout positive adjustable or fixed-mode regulator with minimum output current capability of 1A. The product is specifically designed to provide well-regulated supply for low-voltage IC applications such as high-speed bus-termination and low current 3.3V logic supplies. It is also well suited for other applications such as VGA cards. The APE1117 is guaranteed to have lower than 1.5V dropout at full load current making it ideal to provide well-regulated outputs of 1.25 to 5.0V with 6.4V to 16V input supply.

Typical Applications

- PC peripherals
- Communications

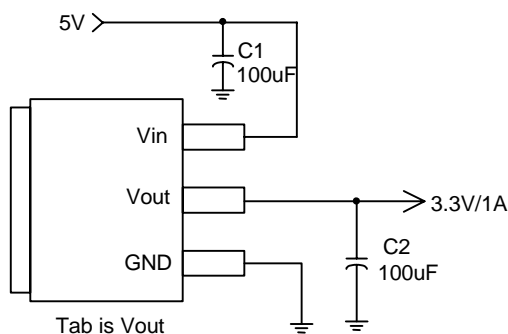

5V/3.3V using fixed output version

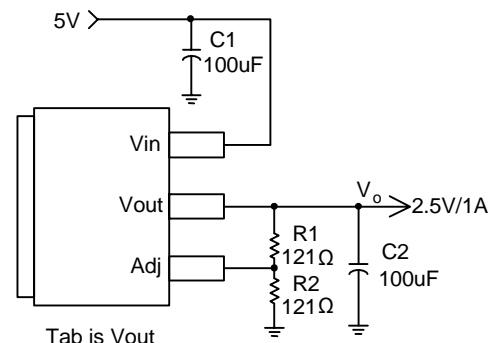

5V/2.5V using adjustable output version

Note: $V_o = V_{REF} * (1 + \frac{R_2}{R_1})$

Ordering information

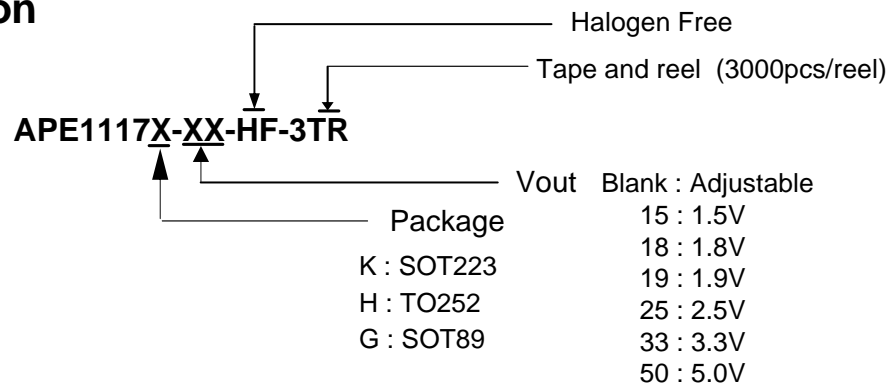

Example: APE1117K-33-HF-3TR 3.3V fixed output in RoHS-compliant, halogen free SOT-223 shipped on tape and reel, 3000pcs/reel



Block Diagram

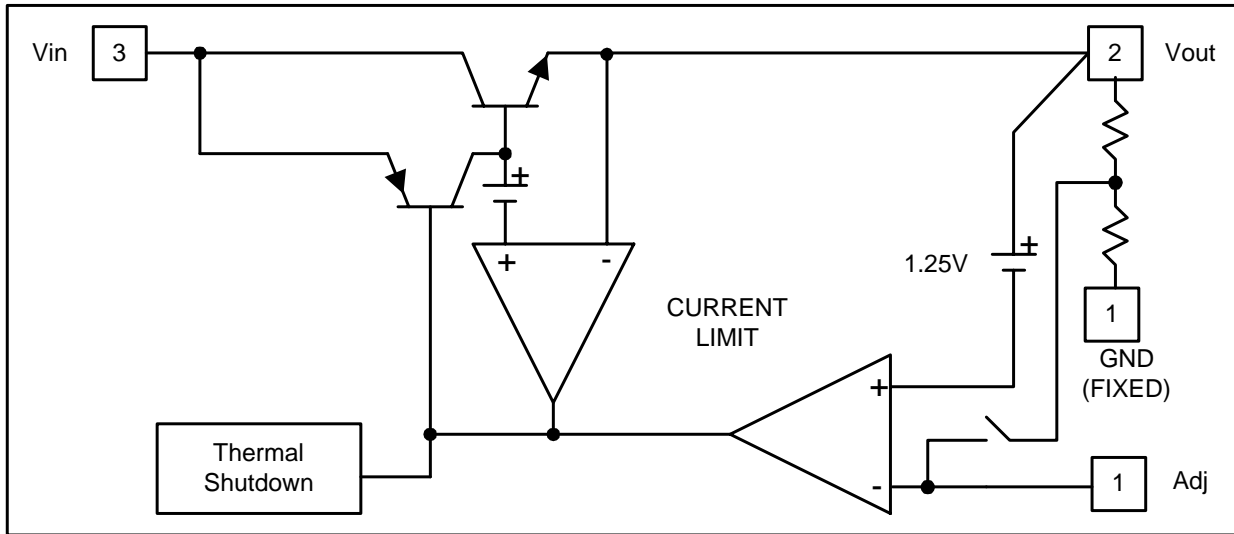

Pin Configurations

3 PIN SOT223

(Top View)

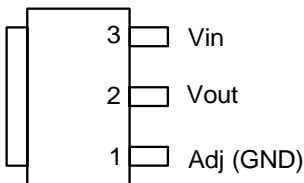

Tab is Vout

3 PIN TO252

(Top View)

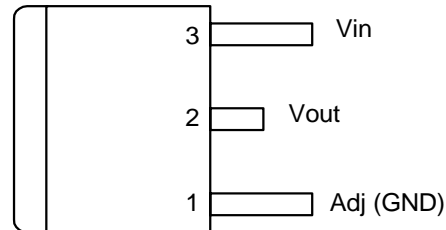

Tab is Vout

3 PIN SOT89

(Top View)

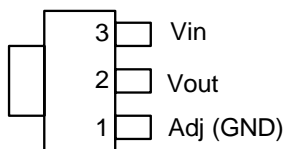

Tab is Vout

THIS PRODUCT IS SENSITIVE TO ELECTROSTATIC DISCHARGE, PLEASE HANDLE WITH CAUTION.

USE OF THIS PRODUCT AS A CRITICAL COMPONENT IN LIFE SUPPORT OR OTHER SIMILAR SYSTEMS IS NOT AUTHORIZED.

APEC DOES NOT ASSUME ANY LIABILITY ARISING OUT OF THE APPLICATION OR USE OF ANY PRODUCT OR CIRCUIT DESCRIBED HEREIN; NEITHER DOES IT CONVEY ANY LICENSE UNDER ITS PATENT RIGHTS, NOR THE RIGHTS OF OTHERS.

APEC RESERVES THE RIGHT TO MAKE CHANGES WITHOUT FURTHER NOTICE TO ANY PRODUCTS HEREIN TO IMPROVE RELIABILITY, FUNCTION OR DESIGN.



Pin Descriptions

NAME	I/O	PIN #	FUNCTION
Adj (GND)	I	1	A resistor divider from this pin to the Vout pin and ground sets the output voltage. (Ground only for Fixed-Mode)
Vout	O	2	The output of the regulator. A capacitor with a minimum value of 10 μ F, 0.15 Ω \leq ESR \leq 1 Ω) must be connected from this pin to ground to ensure stability.
Vin	I	3	The input pin of regulator. Typically a large storage capacitor (0.15 Ω \leq ESR \leq 1 Ω) is connected from this pin to ground to ensure that the input voltage does not sag below the minimum dropout voltage during the load transient response. This pin must always be 1.3V higher than Vout in order for the device to regulate properly.

Absolute Maximum Ratings

Symbol	Parameter	Rating	Unit
Vin	DC Supply Voltage	-0.3 to 16	V
P _D	Power Dissipation	Internally Limited	
T _{ST}	Storage Temperature	-65 to +150	°C
T _{OP}	Operating Junction Temperature Range	0 to +150	°C



Electrical Characteristics

PARAMETER	CONDITIONS		MIN	TYP	MAX	UNIT
Reference Voltage	APE1117-ADJ	$T_J=25^{\circ}\text{C}$, $(V_{IN}-V_{OUT})=1.5\text{V}$ $I_O=10\text{mA}$	1.225	1.250	1.275	V
Output Voltage	APE1117-15	$I_{OUT} = 10\text{mA}$, $T_J = 25^{\circ}\text{C}$, $3\text{V} < V_{IN} < 16\text{V}$	1.470	1.500	1.530	V
	APE1117-18	$I_{OUT} = 10\text{mA}$, $T_J = 25^{\circ}\text{C}$, $3.3\text{V} < V_{IN} < 16\text{V}$	1.764	1.800	1.836	V
	APE1117-19	$I_{OUT} = 10\text{mA}$, $T_J = 25^{\circ}\text{C}$, $3.3\text{V} < V_{IN} < 16\text{V}$	1.862	1.900	1.938	V
	APE1117-25	$I_{OUT} = 10\text{mA}$, $T_J = 25^{\circ}\text{C}$, $4\text{V} < V_{IN} < 16\text{V}$	2.450	2.500	2.550	V
	APE1117-33	$I_{OUT} = 10\text{mA}$, $T_J = 25^{\circ}\text{C}$, $4.8\text{V} < V_{IN} < 16\text{V}$	3.235	3.300	3.365	V
	APE1117-50	$I_{OUT} = 10\text{mA}$, $T_J = 25^{\circ}\text{C}$, $6.5\text{V} < V_{IN} < 16\text{V}$	4.900	5.000	5.100	V
Line Regulation	APE1117-XXX	$I_O=10\text{mA}$, $V_{OUT}+1.5\text{V}<V_{IN}<16\text{V}$, $T_J=25^{\circ}\text{C}$			0.5	%
Load Regulation	APE1117-ADJ	$V_{IN}=3.3\text{V}$, $V_{adj}=0$, $10\text{mA}<I_O<1\text{A}$, $T_J=25^{\circ}\text{C}$ (Note 1,2)			1	%
	APE1117-15	$V_{IN}=3\text{V}$, $10\text{mA}<I_O<1\text{A}$, $T_J=25^{\circ}\text{C}$ (Note 1,2)		12	15	mV
	APE1117-18	$V_{IN}=3.3\text{V}$, $10\text{mA}<I_O<1\text{A}$, $T_J=25^{\circ}\text{C}$ (Note 1,2)		15	18	mV
	APE1117-19	$V_{IN}=3.3\text{V}$, $10\text{mA}<I_O<1\text{A}$, $T_J=25^{\circ}\text{C}$ (Note 1,2)		16	19	mV
	APE1117-25	$V_{IN}=4\text{V}$, $10\text{mA}<I_O<1\text{A}$, $T_J=25^{\circ}\text{C}$ (Note 1,2)		20	25	mV
	APE1117-33	$V_{IN} = 5\text{V}$, $10\text{mA}<I_O<1\text{A}$, $T_J=25^{\circ}\text{C}$ (Note 1,2)		26	33	mV
	APE1117-50	$V_{IN} = 6.5\text{V}$, $10\text{mA}<I_O<1\text{A}$, $T_J=25^{\circ}\text{C}$ (Note 1,2)		40	50	mV
Dropout Voltage ($V_{IN}-V_{OUT}$)	APE1117-ADJ/15/18 /19/25/33/50	$I_{OUT} = 1\text{A}$, $\Delta V_{OUT}=1\%V_{OUT}$		1.3	1.5	V
Current Limit	APE1117-ADJ/15/18 /19/25/33/50	$(V_{IN}-V_{OUT}) = 5\text{V}$	1.1			A
Minimum Load Current	APE1117-XXX	$0^{\circ}\text{C} < T_J < 125^{\circ}\text{C}$		5	10	mA
Thermal Regulation	$T_A=25^{\circ}\text{C}$, 30ms pulse			0.008	0.04	%/W
Ripple Rejection	$F=120\text{Hz}$, $C_{OUT}=25\mu\text{F}$ Tantalum, $I_{OUT}=1\text{A}$					
	APE1117-XXX	$V_{IN}=V_{OUT}+3\text{V}$		60	70	dB
Temperature Stability	$I_O=10\text{mA}$			0.5		%
Thermal Shutdown Temperature				150		$^{\circ}\text{C}$
Thermal Shutdown Temperature Recovery				130		$^{\circ}\text{C}$
J_A Thermal Resistance Junction-to-Ambient (No heat sink; no air flow)	SOT89 SOT-223 TO-252			300 117 92		$^{\circ}\text{C}/\text{W}$
J_C Thermal Resistance Junction-to-Case	SOT89 : Control Circuitry/Power Transistor SOT-223 : Control Circuitry/Power Transistor TO-252 : Control Circuitry/Power Transistor			100 15 10		$^{\circ}\text{C}/\text{W}$

Note1: See thermal regulation specifications for changes in output voltage due to heating effects. Line and load regulation are measured at a constant junction temperature by low duty cycle pulse testing. Load regulation is measured at the output load = 1/18" from the package.

Note2: Line and load regulation are guaranteed up to the maximum power dissipation of 15W. Power dissipation is determined by the difference between input and output differential and the output current. Guaranteed maximum power dissipation will not be available over the full input/output range.

Note3: Quiescent current is defined as the minimum output current required in maintaining regulation. At 12V input/output differential the device is guaranteed to regulate if the output current is greater than 10mA.



Electrical Characteristics (cont.)

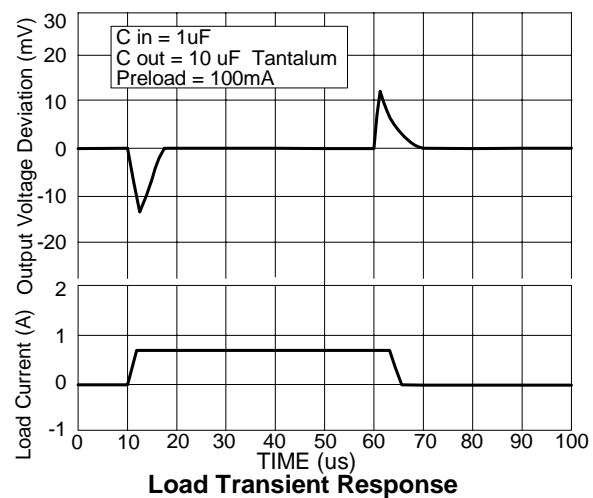
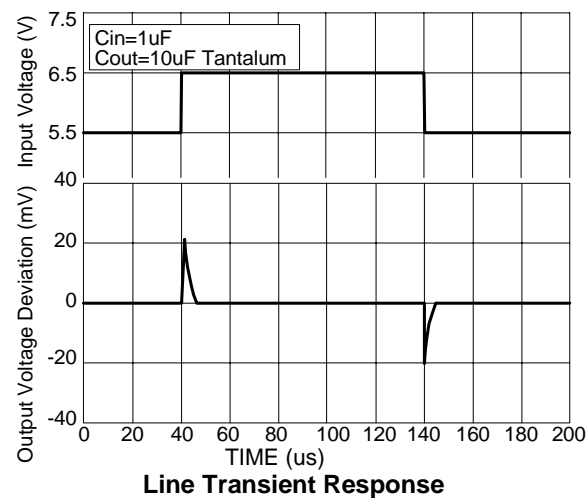
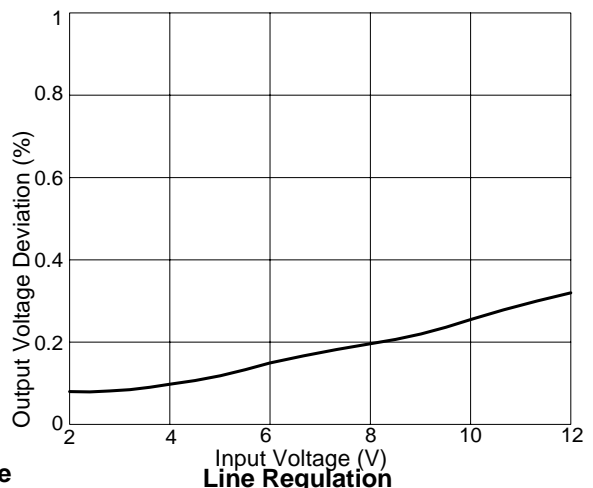
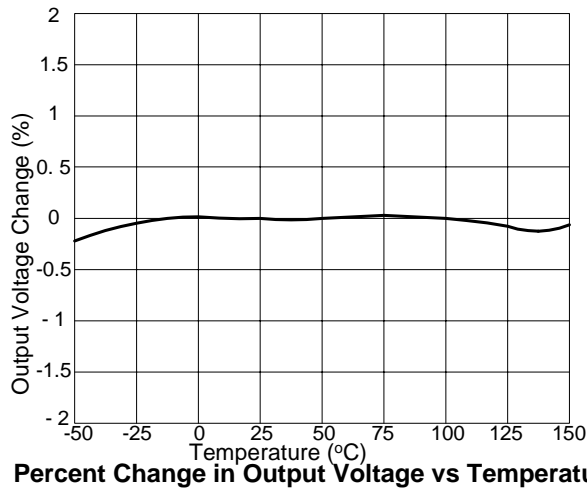
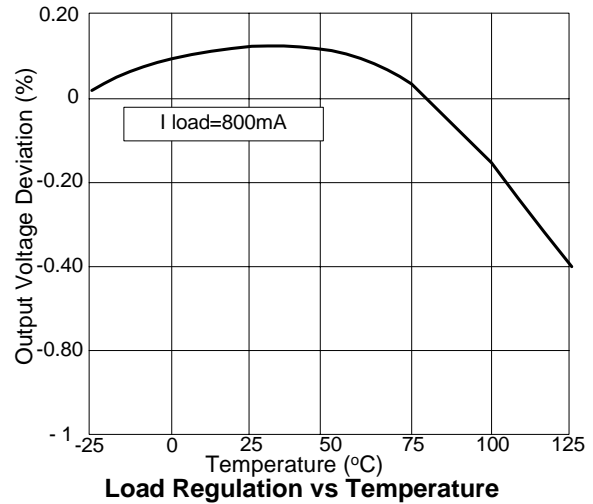
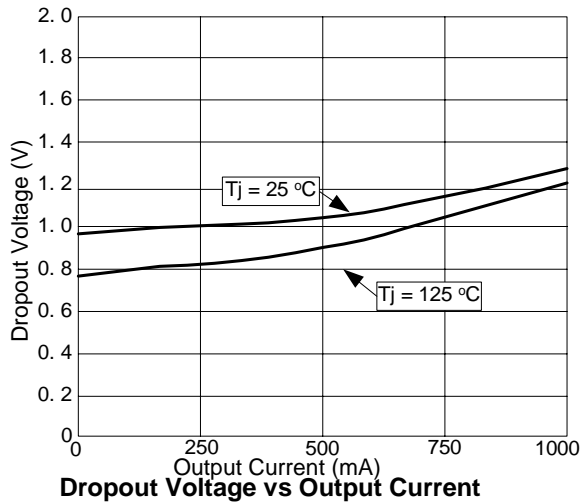



Marking Information

SOT-223

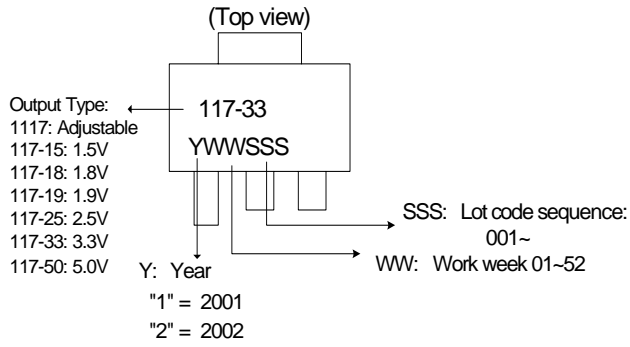

TO-252

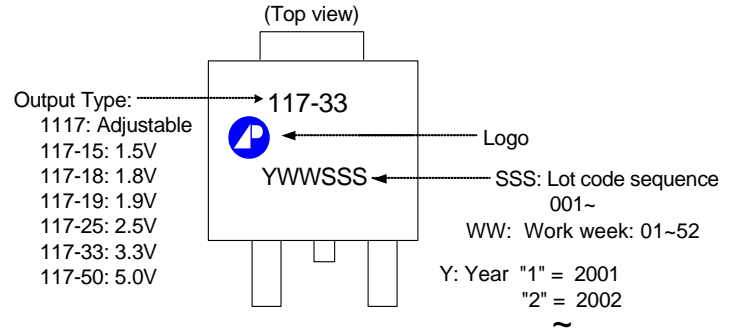

SOT-89

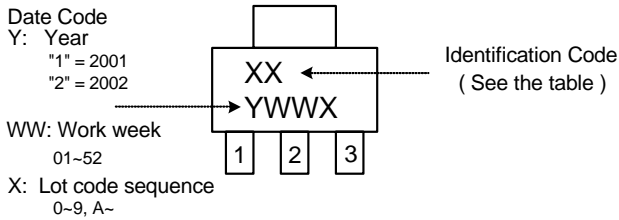

Identification code	Output version
EA	APE1117-ADJ
EB	APE1117-1.5V
EC	APE1117-1.8V
EG	APE1117-1.9V
ED	APE1117-2.5V
EE	APE1117-3.3V
EF	APE1117-5.0V



Package Dimensions: TO-252

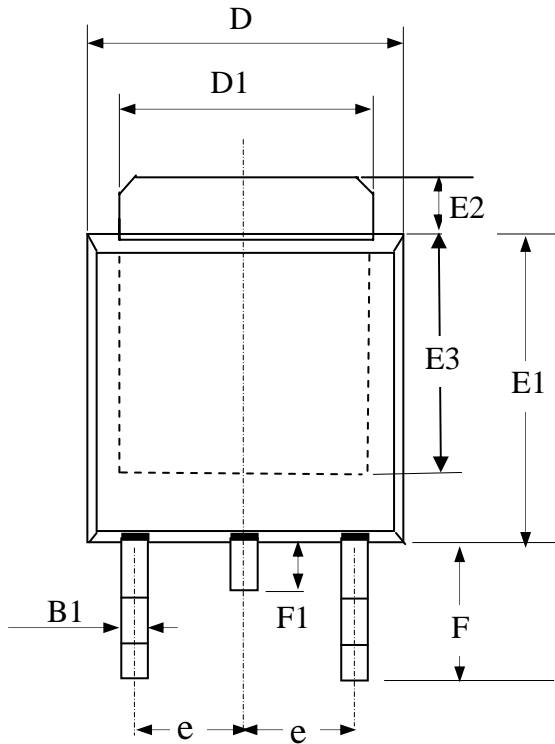

SYMBOLS	Millimeters		
	MIN	NOM	MAX
A2	1.80	2.30	2.80
A3	0.40	0.50	0.60
B1	0.40	0.70	1.00
D	6.00	6.50	7.00
D1	4.80	5.35	5.90
E3	3.50	4.00	4.50
F	2.20	2.63	3.05
F1	0.50	0.85	1.20
E1	5.10	5.70	6.30
E2	0.50	1.10	1.80
e	--	2.30	--
C	0.35	0.50	0.65

1. All dimensions are in millimeters.
2. Dimensions do not include mold protrusions.

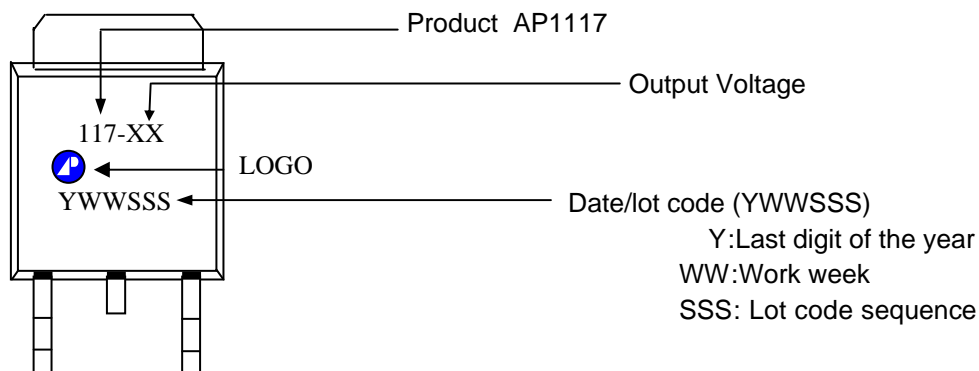
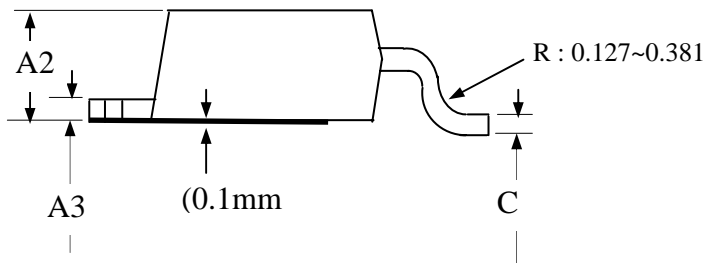



Package Dimensions: SOT-223

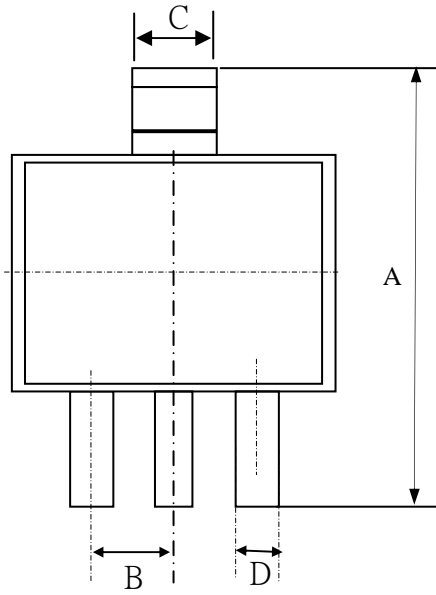

SYMBOLS	Millimeters		
	MIN	NOM	MAX
A	6.70	7.00	7.30
B	---	2.30	---
C	2.90	3.00	3.10
D	0.60	0.70	0.80
G	0.25	0.30	0.35
E	6.30	6.50	6.70
F	1.40	1.60	1.80
K	0.02	0.06	0.10

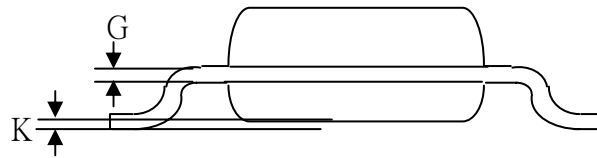
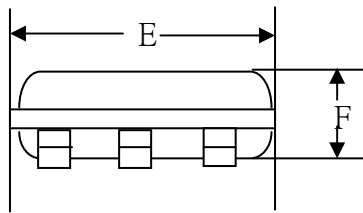

1. All dimensions are in millimeters.
2. Dimensions do not include mold protrusions.

Marking Information

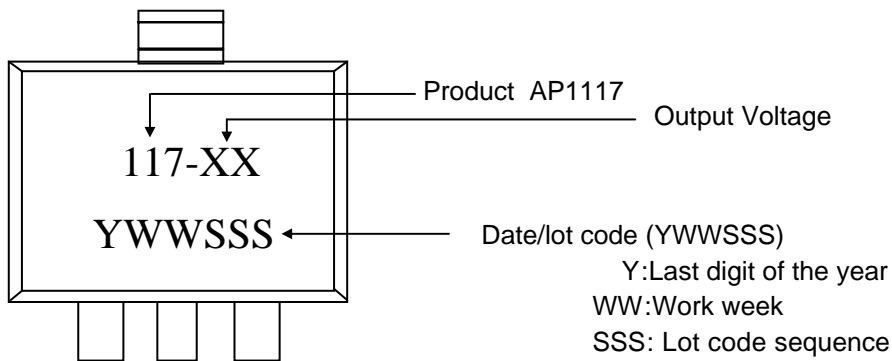



Package Dimensions: SOT-89

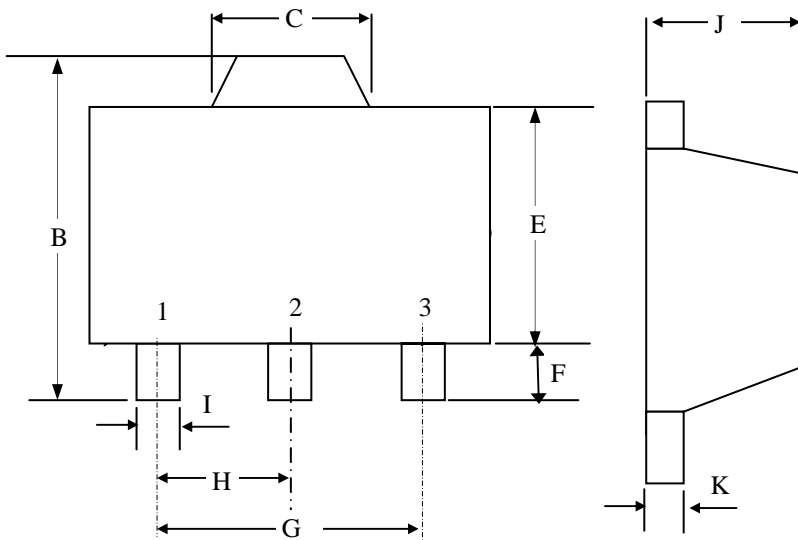

SYMBOLS	Millimeters		
	MIN	NOM	MAX
A	4.40	-	4.60
B	4.05	-	4.25
C	1.40	-	1.75
E	2.40	-	2.60
F	0.89	-	1.20
I	0.35	-	0.55
H	----	1.50	----
G	----	3.00	----
J	1.40	-	1.60
K	0.35	-	0.43

1. All dimensions are in millimeters.
2. Dimensions do not include mold protrusions.

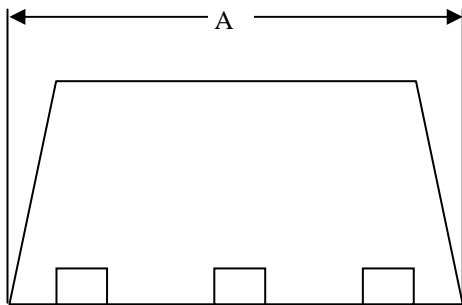

Marking Information

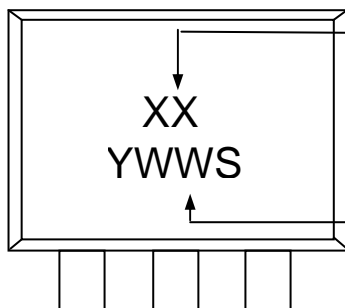

Product: See table page 6

Date/lot code (YWWS)

Y: Last digit of the year

WW: Work week

S: Lot code sequence