

## METALLIZED POLYESTER FILM CAPACITORS

### SCHEMATIC CROSS SECTION

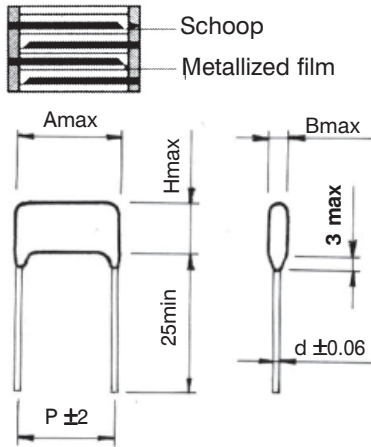

**TYPICAL APPLICATIONS:** blocking, coupling, decoupling, by-passing, interference suppression in low voltage applications.

### GENERAL TECHNICAL DATA

**Dielectric:** Polyester film (polyethylene terephthalate)  
**Plates:** aluminium layer deposited by evaporation under vacuum.  
**Protection:** phenol-formaldehyde resin  
**Climatic category:** 40/85/21 IEC 68-1  
**Related documents:** IEC 384-2

### ELECTRICAL CHARACTERISTICS

**Capacitance range:**  $C_R = 4.7 \text{ nF to } 5\mu\text{F (E12)}$   
**Capacitance tolerance:**  $\pm 5; \pm 10; \pm 20\%$   
**Rated voltage:**  $U_R = 63; 160; 250; 400; 630 \text{ VDC}$   
**Category voltage:**  $U_C = 0.80 U_R / 100^\circ\text{C}$   
**Test voltage:**  $U_e = 1.4 U_R / 2 \text{ s at } 25^\circ\text{C}$   
**Dissipation factor:**  $\text{tg}\delta \leq 100 \times 10^{-4} \text{ at } 1 \text{ kHz}$   
**Insulation resistance at } 20^\circ\text{C}**

Between terminals	$U_R < 100 \text{ V}$	$C_R \leq 0.33 \mu\text{F}$ $R_i \geq 3.75 \text{ G}\Omega$	$C_R > 0.33 \mu\text{F}$ $R_i \times C_R \geq 1250 \text{ s}$
	$U_R > 100 \text{ V}$	$R_i \geq 7.5 \text{ G}\Omega$	$R_i \times C_R \geq 2500 \text{ s}$
Between terminals and capacitor body		$R_i \geq 30 \text{ G}\Omega$	

### Max pulse rise time (dv/dt)

$U_R$	Lead spacing „P“ (mm)					dv/dt (V/μs)
	10	12.5	17.5	22.5	32.5	
63	3	3	1.5	1	1	dv/dt (V/μs)
160	8	5	5	3	2	dv/dt (V/μs)
250	11	7	4	3	3	dv/dt (V/μs)
400	20	10	5.5	5	5	dv/dt (V/μs)
630	30	30	15	8	7	dv/dt (V/μs)

### TEST METHOD AND PERFORMANCE

#### Damp heat, steady state:

#### Test conditions

Temperature:  $+ 40^\circ\text{C} \pm 2^\circ\text{C}$   
 Relative humidity (RH):  $93\% \pm 2\%$   
 Test duration: 21 days

#### Performance

Capacitance change  $\Delta C/C$ :  $\leq \pm 5\%$   
 DF change  $\Delta \text{tg}\delta$ :  $\leq 50 \times 10^{-4} \text{ at } 1 \text{ kHz}$   
 Insulation resistance:  $\geq 50\%$  of initial limit

#### Endurance:

#### Test conditions

Temperature:  $+ 85^\circ\text{C} \pm 2^\circ\text{C}$   
 Test duration: 1000 h  
 Voltage applied:  $1.25 \times U_R$

#### Performance

Capacitance change  $\Delta C/C$ :  $\leq \pm 5\%$   
 DF change  $\Delta \text{tg}\delta$ :  $\leq 50 \times 10^{-4} \text{ at } 10 \text{ kHz for } C \leq 1\mu\text{F}$   
 $\leq 30 \times 10^{-4} \text{ at } 1 \text{ kHz for } C > 1\mu\text{F}$   
 Insulation resistance:  $\geq 50\%$  of initial limit

#### Resistance to soldering heat:

#### Test conditions

Solder bath temperature:  $+ 260^\circ\text{C} \pm 5^\circ\text{C}$   
 Dipping time (with heat screen):  $10 \pm 1 \text{ s}$

#### Performance

Capacitance change  $\Delta C/C$ :  $\leq \pm 2\%$   
 DF change  $\Delta \text{tg}\delta$ :  $\leq 50 \times 10^{-4} \text{ at } 10 \text{ kHz for } C \leq 1\mu\text{F}$   
 $\leq 30 \times 10^{-4} \text{ at } 1 \text{ kHz for } C > 1\mu\text{F}$   
 Insulation resistance:  $\geq$  initial limit

### Ordering code

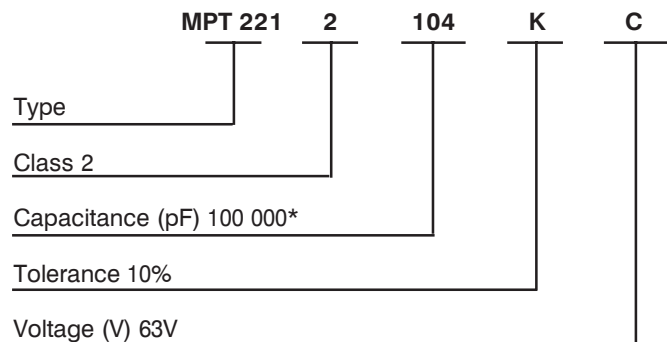

\* The last figure indicates the number of zeroes

#### - Marking:

Type  
 Rated capacitance in nF or μF  
 Capacitance tolerance J (5%); K (10%); M (20%)  
 DC rated voltage

Example: 100 n K 63 100 nF  $\pm 10\%$  63V  
2μ2 M 250 2.2 μF  $\pm 20\%$  250V

**CAPACITANCE VALUE ( $C_R$ ) RATED VOLTAGE ( $U_R$ ) AND DIMENSIONS (mm)**

$U_R$ (VDC)	63 and 160				250				400				630			
Letter code	C		E		F				G				I			
$C_R$ ( $\mu$ F)	Amax	Bmax	Hmax	P	Amax	Bmax	Hmax	P	Amax	Bmax	Hmax	P	Amax	Bmax	Hmax	P
0.0047					15.0	5.6	10.0	12.5	15.0	5.6	10.0	12.5	15.0	5.6	10.0	12.5
0.0051					15.0	5.8	10.2	12.5	15.0	5.8	10.2	12.5	15.0	5.8	10.2	12.5
0.0068					15.0	5.9	10.3	12.5	15.0	5.9	10.3	12.5	15.0	6.5	10.9	12.5
0,010	15,0	5,0	8,2	12,5	15,0	5,0	8,2	12,5	15,0	5,0	8,2	12,5	15,0	5,0	8,2	12,5
	13,0	5,2	8,6	10,0	13,0	5,2	6,6	10,0	13,0	5,2	8,6	10,0				
0,015	15.0	4.7	8.3	12.5	15.0	4.7	8.3	12.5	15.0	4.7	8.3	12.5	15.0	4.7	8.3	12.5
	13.0	5.2	8.6	10.0	13.0	5.2	8.6	10.0	13.0	5.2	8.6	10.0				
0.022	15.0	4.9	8.5	12.5	15.0	4.9	8.5	12.5	15.0	4.9	8.5	12.5	15.0	4.9	8.5	12.5
	13.0	5.2	8.6	10.0	13.0	5.4	8.8	10.0	13.0	5.4	8.8	10.0				
0.033	15.0	5.8	10.0	12.5	15.0	5.8	10.0	12.5	15.0	5.8	10.0	12.5	15.0	6.0	10.4	12.5
					13.0	5.0	10.6	10.0	13.0	6.0	10.6	10.0				
0.047	15.0	6.0	10.4	12.5	15.0	6.0	10.4	12.5	15.0	6.0	10.4	12.5	20.0	6.0	10.6	17.5
					13.0	6.4	10.6	10.0	13.0	6.4	10.6	10.0				
0.068	15.0	4.8	8.3	12.5	15.0	4.8	8.3	12.5	15.0	7.1	11.5	12.5	20.0	6.6	11.6	17.5
					13.0	5.4	8.4	10.0	13.0	6.4	11.9	10.0				
0.10	15.0	5.4	8.9	12.5	15.0	5.4	8.9	12.5	20.0	6.2	11.4	17.5	20.0	7.3	12.0	17.5
					13.0	5.6	9.2	10.0								
0.12	15.0	5.9	9.5	12.5	15.0	5.9	9.5	12.5	20.0	6.8	12.0	17.5	25.0	6.2	11.5	22.5
					13.0	6.2	9.8	10.0								
0.15	15.0	6.7	10.6	12.5	15.0	6.7	10.6	12.5	20.0	7.6	12.8	17.5	25.0	6.6	12.3	22.5
					13.0	6.9	11.4	10.0								
0.18	15.0	6.3	10.7	12.5	20.0	5.5	9.8	17.5	20.0	8.1	13.2	17.5	25.0	7.0	13.5	22.5
0.22	15.0	6.7	11.0	12.5	20.0	5.9	10.1	17.5	25.0	9.2	13.5	22.5	25.0	8.1	14.2	22.5
0.33	20.0	6.0	11.2	17.5	20.0	6.9	11.5	17.5	25.0	9.8	14.3	22.5				
0.39	20.0	6.5	11.7	17.5	20.0	7.3	12.4	17.5	25.0	10.2	15.2	22.5				
0.47	20.0	6.8	12.0	17.5	25.0	6.5	12.2	22.5	25.0	10.5	16.9	22.5				
0.56	20.0	7.4	12.6	17.5	25.0	7.0	12.8	22.5	25.0	11.8	17.9	22.5				
0.68	20.0	7.9	13.1	17.5	25.0	7.4	13.0	22.5	35.0	8.6	16.2	32.5				
0.82	20.0	8.3	13.5	17.5	25.0	8.1	13.7	22.5	35.0	9.7	17.0	32.5				
1.0	25.0	7.5	12.7	22.5	25.0	8.7	14.5	22.5	35.0	10.0	18.0	32.5				
1.2	25.0	8.6	13.8	22.5	25.0	9.5	15.3	22.5								
1.5	25.0	8.8	15.5	22.5	25.0	10.0	16.3	22.5								
2.2	25.0	10.2	17.1	22.5	35.0	9.0	19.0	32.5								
4.0	35.0	11.2	20.3	32.5	40.0	11.3	20.3	37.5								
5.0	35.0	11.3	21.2	32.5												

\* For P < 22.5 mm d=0.6 mm  
 \* For P ≥ 22.5 mm d=0.8 mm

## CHARACTERISTICS CURVES

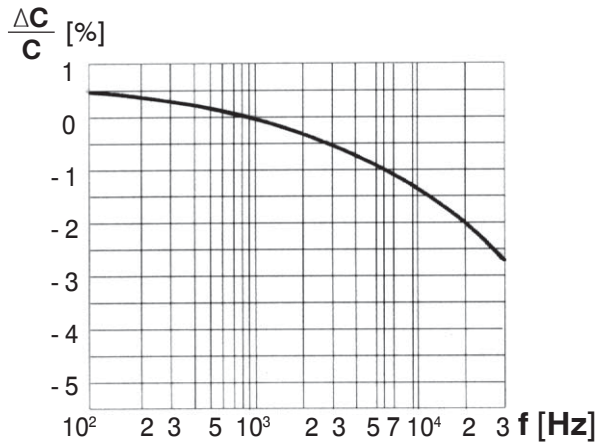

Capacitance vs. frequency

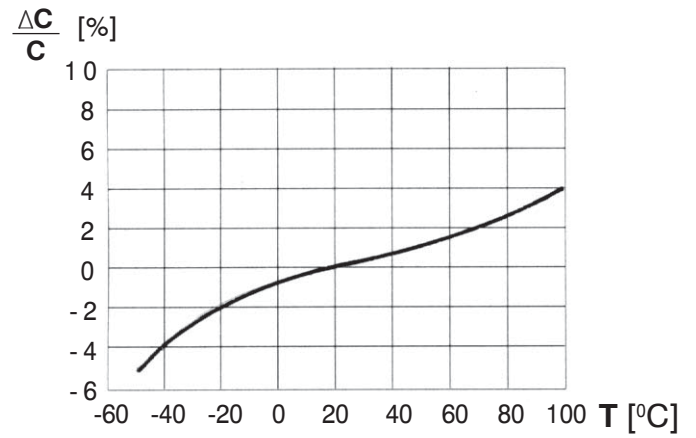

Capacitance vs. temperature at 1 kHz

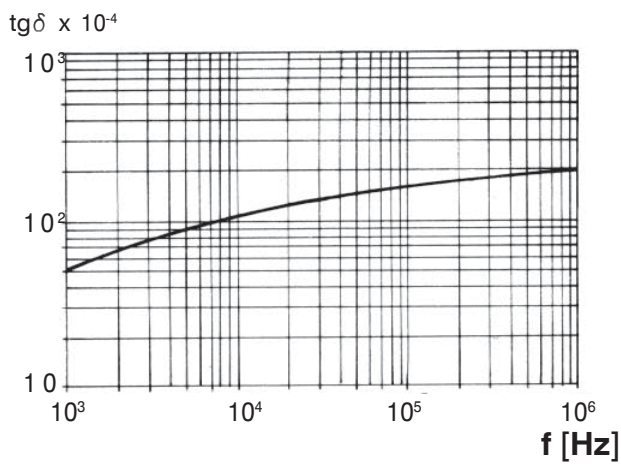

Dissipation factor vs. frequency

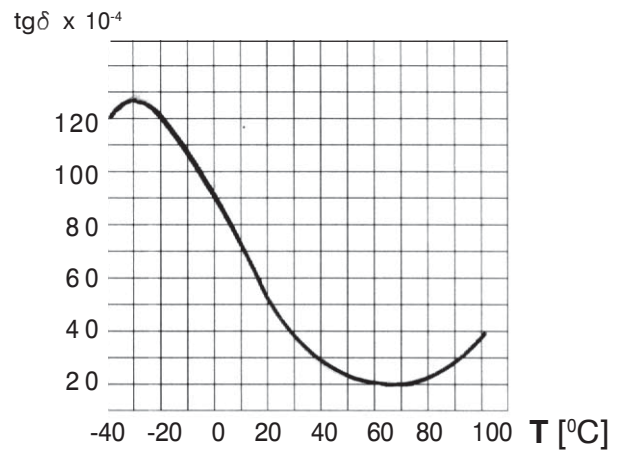

Dissipation factor vs. temperature

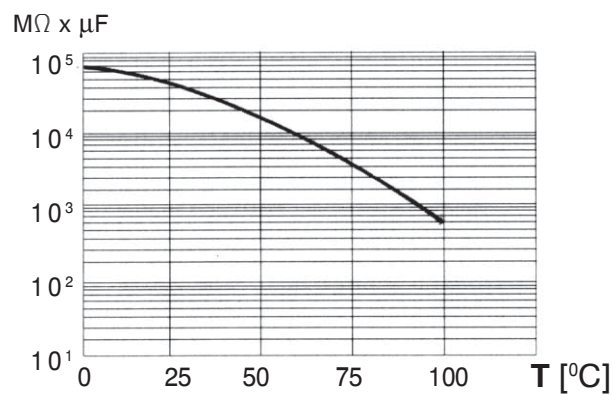

Time constant vs. temperature