

ET-5630 0.5W CRI 80 Datasheet



Features :

- High luminous Intensity and high efficiency
- Based on Blue : InGaN technology
- Wide viewing angle : 120°
- Excellent performance and visibility
- Suitable for all SMT assembly methods
- IR reflow process compatible
- Environmental friendly; RoHS compliance

Typical Applications :

- Signal and Symbol Luminaire
- Indoor Displays
- Backlighting (illuminated advertising, general lighting)

Table of Contents

General Information	3
Absolute Maximum Ratings	4
Characteristics	4
Luminous Flux Characteristic.....	5
Voltage Bin Structure	5
Mechanical Dimensions.....	6
Characteristic Curve	7
Reflow Profile	9
Product Packaging Information.....	10
Revision History	11
About Edison Opto	11

General Information

Introduction

Ultra high luminous efficacy, combined with the flexibility in design due to its slim and miniature size, PLCC LED Series are optimized to be used as lighting for signboard.

Ordering Code Format

<u>2</u> X1	<u>T</u> X2	<u>XX</u> X3-X4	<u>XX</u> X5-X6	<u>XX</u> X7-X8	<u>XX</u> X9-X10	<u>000</u> X11-X13	<u>XXX</u> X14-X16		
X1 Type	X2 Component	X3-X4 Series		X5-X6 Wattage		X7-X8 Color			
2	Emitter (L1)	T	PLCC	01	3014	01	1W	CW	Cool White
				03	3528	X1	0.1W	NW	Neutral White
				04	5050	X2	0.2W	WW	Warm White
				05	5630	X5	0.5W	RX	Red
						Y6	0.06W	TX	True Green
								BX	Blue
								AX	Amber
								YX	Yellow
								OX	Red Orange
								M1	RGB

X9-X10	X11-X13	X14-X16
Internal code	PCB Board	Serial Number
-	-	000
-	-	-

Absolute Maximum Ratings

Parameter	Symbol	Value	Units
Forward Current	I_F	200	mA
Pulse Forward Current (tp<=100μs, Duty cycle=0.25)	I_{pulse}	400	mA
Reverse Current	I_R	10	uA
Reverse Voltage	V_R	5	V
LED Junction Temperature	T_J	125	°C
Operating Temperature	-	-40 ~ +80	°C
Storage Temperature	-	-40 ~ +125	°C
ESD Sensitivity	V_B	2,000	V
Soldering Temperature	T_s	Reflow Soldering : 255~260°C/10~30sec Manual Soldering : 350°C/3sec	

Absolute maximum ratings ($T_a=25^{\circ}\text{C}$)

Notes:

1. Proper current derating must be observed to maintain junction temperature below the maximum at all time.
2. LEDs are not designed to be driven in reverse bias.

Characteristics

Parameter	Symbol	Value	Units
Viewing Angle (Typ.)	$2\theta_{1/2}$	120	Degree
Thermal resistance	-	20	°C/W
CRI	-	80	-
CCT/Wavelength	(Cool White)	5,000 - 10,000	K
	(Neutral White)	3,800 - 5,000	
	(Warm White)	2,670 - 3,800	

Note:

$2\theta_{1/2}$ is the off-axis angle where the luminous intensity is half of the axial luminous intensity.

Luminous Flux Characteristic

Luminous Flux Characteristics, $I_f=150\text{mA}$ and $T_j=25^\circ\text{C}$

Color	Group	Min Luminous Flux(lm)	Max Luminous Flux(lm)	Forward Current(mA)	Order Code
Cool White	R1	39.4	45.3	150	2T05X5CW14000001
	R2	45.3	51.2		
	S1	51.2	58.8		
Neutral White	R1	39.4	45.3	150	2T05X5NW11000001
	R2	45.3	51.2		
	S1	51.2	58.8		
Warm White	R1	39.4	45.3	150	2T05X5WW11000001
	R2	45.3	51.2		
	S1	51.2	58.8		

Note:

The luminous flux performance is guaranteed within published operating conditions. Edison Opto maintains a tolerance of $\pm 10\%$ on flux measurements.

Voltage Bin Structure

Group	Min Voltage (V)	Max Voltage (V)
VC1	3.0	3.1
VA2	3.1	3.2
VB2	3.2	3.3
VC2	3.3	3.4
VA3	3.4	3.5
VB3	3.5	3.6

Note:

Forward voltage measurement allowance is $\pm 0.1\text{V}$.

Mechanical Dimensions

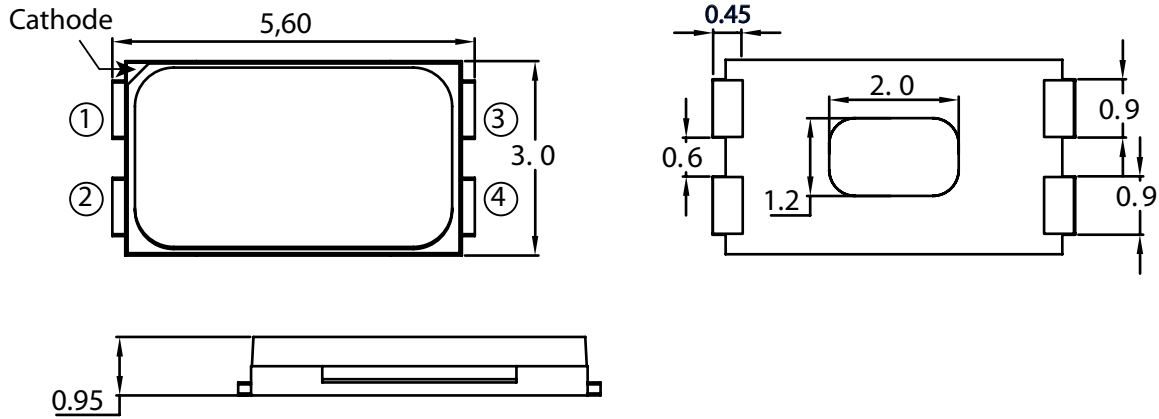

Circuit

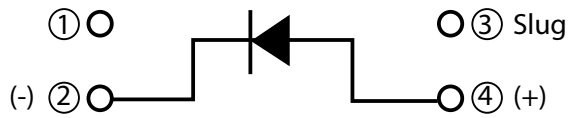

Solder Pad

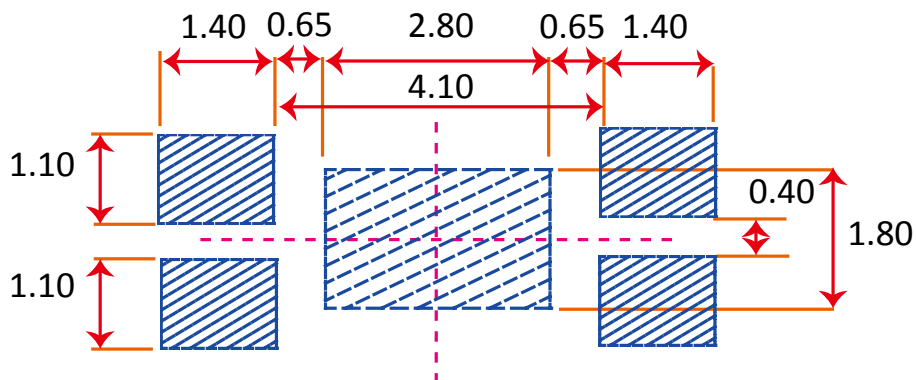

Notes:

1. All dimensions are measured in mm.
2. Tolerance : ± 0.20 mm

Characteristic Curve

Color Spectrum

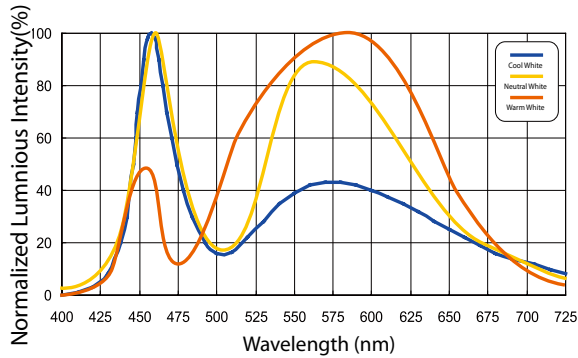

Color Spectrum at a typical CCT for PLCC 5630 series

Beam Pattern

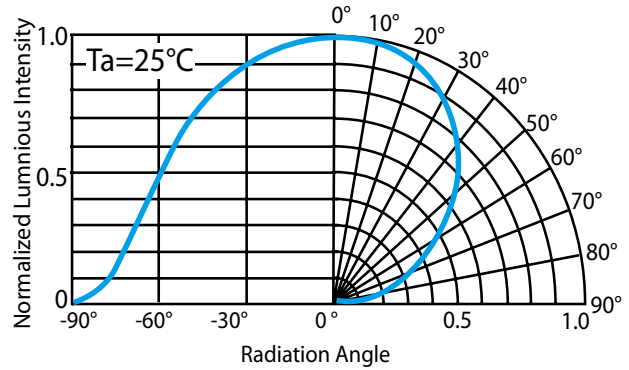

Beam pattern diagram for PLCC 5630 series

Forward voltage vs. Forward Current

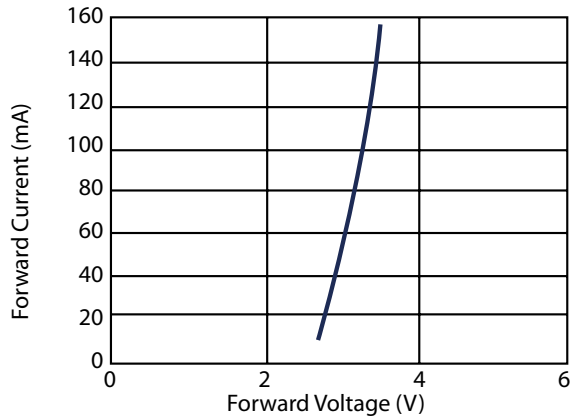

Forward Voltage vs. Forward Current for PLCC 5630 series

Forward Current vs. Relative Intensity

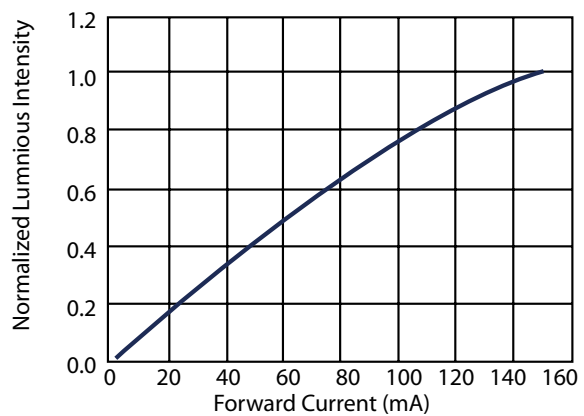

Forward Current vs. Luminous Intensity for PLCC 5630 series

Ambient temperature vs. Forward Current

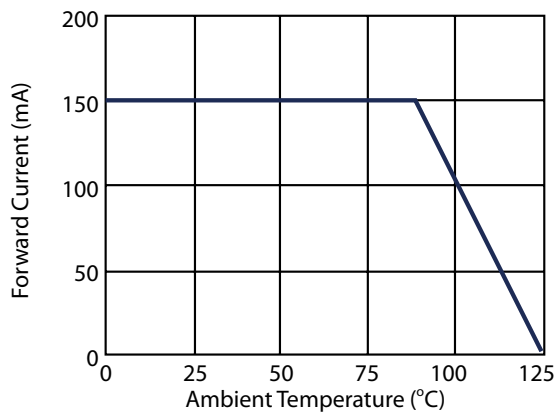

Ambient Temperature vs. Forward Current for PLCC 5630 series

Junction Temperature vs. Forward Voltage

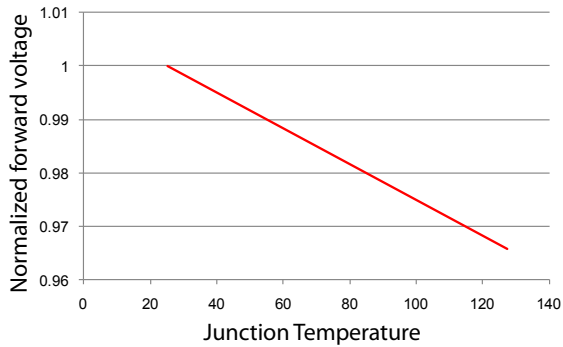

Forward Voltage vs. Junction Temperature for PLCC 5630 series

Junction Temperature vs. CCT

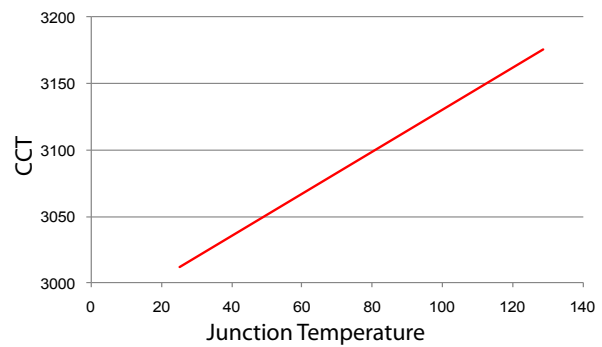

Junction Temperature vs. CCT for PLCC 5630 series Warm White

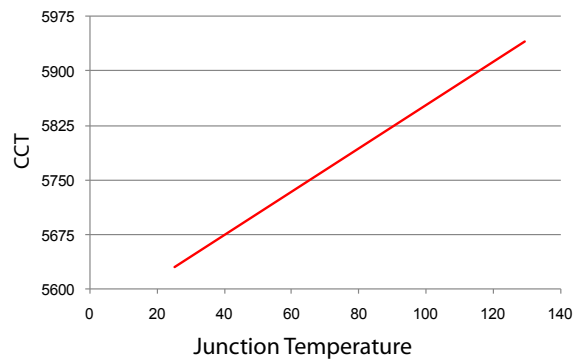

Junction Temperature vs. CCT for PLCC 5630 series Cool White

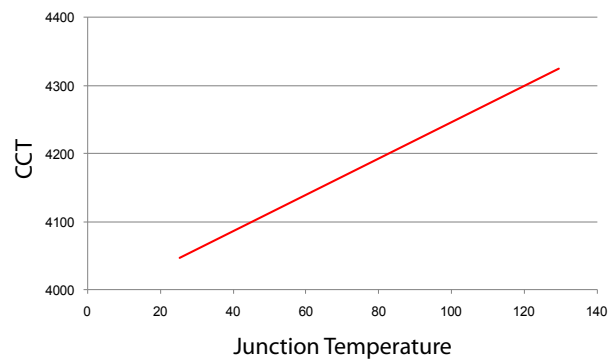

Junction Temperature vs. CCT for PLCC 5630 series Neutral White

Junction Temperature vs. Luminous Intensity

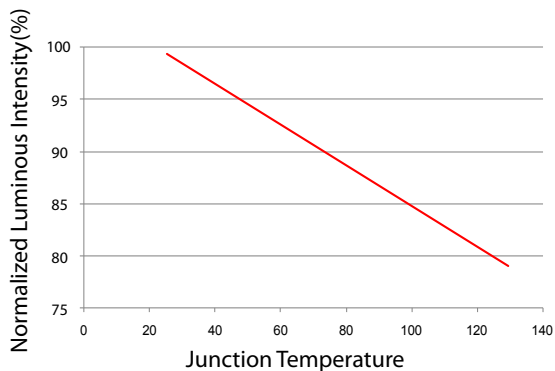

Junction Temperature vs. Luminous Intensity for PLCC 5630 series

Reflow Profile

The following reflow profile is from IPC/JEDEC J-STD-020D which provided here for reference.

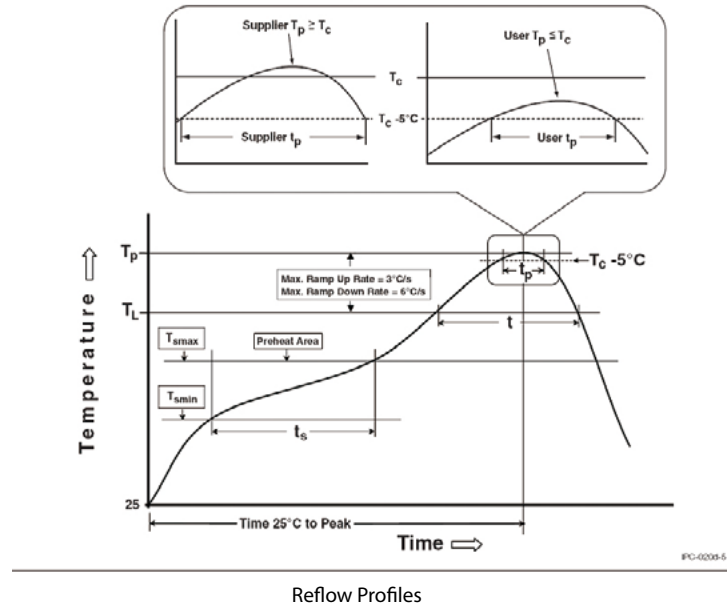

Classification Reflow Profiles

Profile Feature	Pb-Free Assembly
Preheat & Soak Temperature min (T_{smin}) Temperature max (T_{smax}) Time (T_{smin} to T_{smax}) (ts)	150 °C 200 °C 60-120 seconds
Average ramp-up rate (T_{smax} to T_p)	3 °C/second max.
Liquidous temperature (T_L) Time at liquidous (t_L)	217 °C 60-150 seconds
Peak package body temperature (T_p)*	255 °C ~260 °C *
Classification temperature (T_c)	260 °C
Time (t_p)** within 5 °C of the specified classification temperature (T_c)	30** seconds
Average ramp-down rate (T_p to T_{smax})	6°C/second max.
Time 25°C to peak temperature	8 minutes max.

Notes:

- * Tolerance for peak profile temperature (T_p) is defined as a supplier minimum and a user maximum.
- ** Tolerance for time at peak profile temperature (t_p) is defined as a supplier minimum and a user maximum.

Product Packaging Information

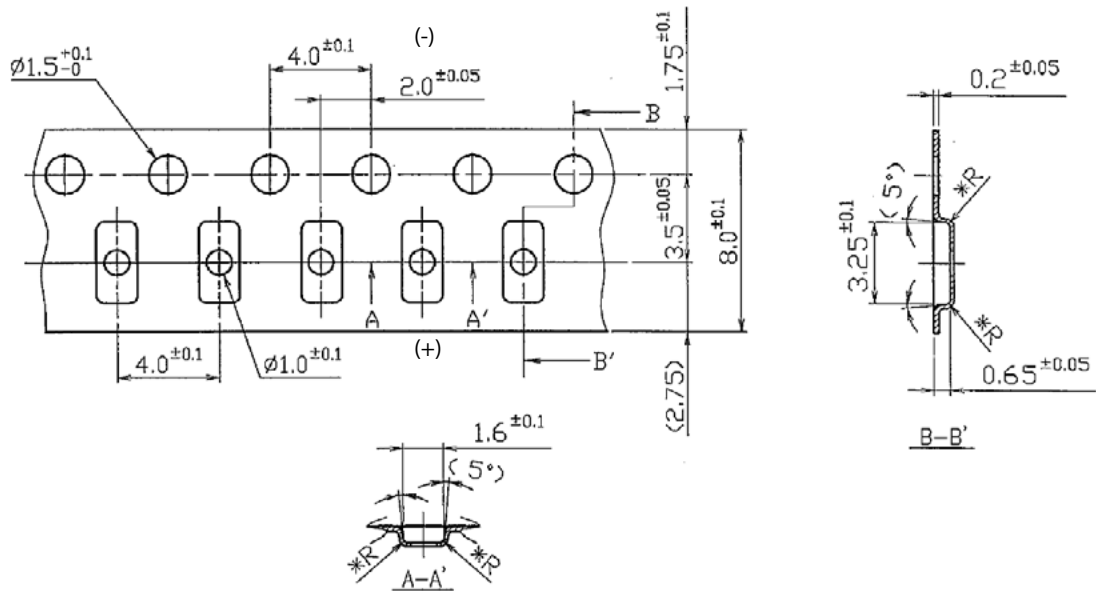

Taping Reel

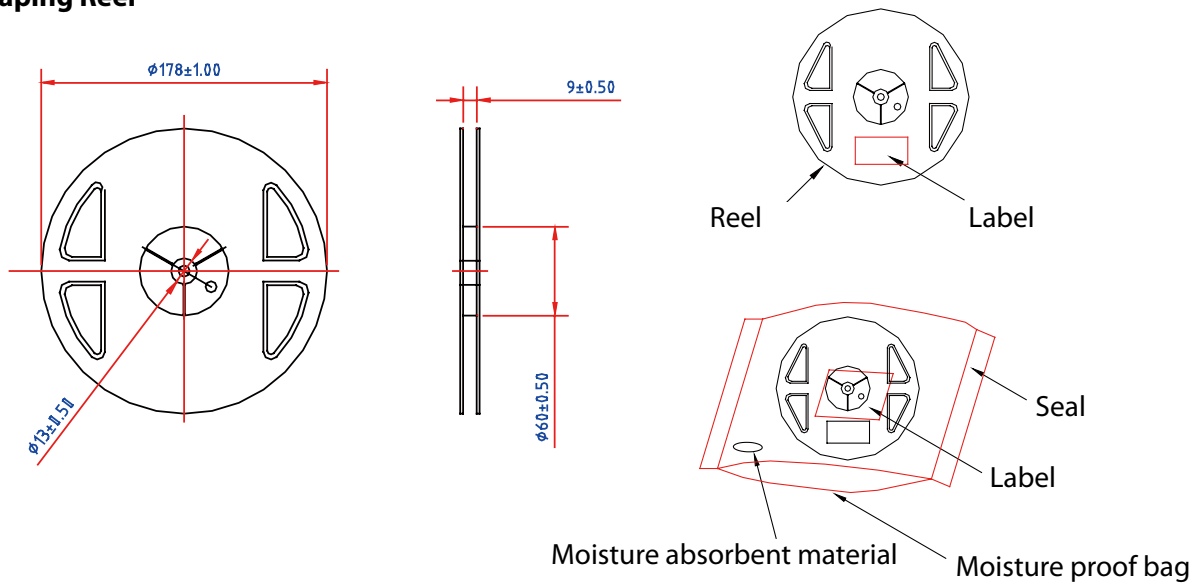

Item	Quantity	Total	Dimensions(mm)
Reel	3,000pcs	3,000pcs	R=178
Carton	36 reels	108,000pcs	520*255*285
Starting with 50pcs empty, and 50pcs empty at the last			

Revision History

Versions	Description	Release Date
1	Establish order code information	2013/01/07
2	Add the characteristic curve	2013/03/11
3	1. Revise the Dimension of Solder Pad 2. Update the Characteristic	2013/05/07

About Edison Opto

Edison Opto is a leading manufacturer of high power LED and a solution provider experienced in LDMS. LDMS is an integrated program derived from the four essential technologies in LED lighting applications- Thermal Management, Electrical Scheme, Mechanical Refinement, Optical Optimization, to provide customer with various LED components and modules. More Information about the company and our products can be found at www.edison-opto.com

Copyright©2013 Edison Opto. All rights reserved. No part of publication may be reproduced or transmitted in any form or by any means, electronic or mechanical, including photo copy, recording or any other information storage and retrieval system, without prior permission in writing from the publisher. The information in this publication are subject to change without notice.

www.edison-opto.com

For general assistance please contact:
service@edison-opto.com.tw

For technical assistance please contact:
LED.Detective@edison-opto.com.tw