

KAA-3528SURKSYKC

HYPER RED

SUPER BRIGHT YELLOW

### Features

- BOTH CHIPS CAN BE CONTROLLED SEPARATELY.
- SUITABLE FOR ALL SMT ASSEMBLY AND SOLDER PROCESS.
- AVAILABLE ON TAPE AND REEL.
- PACKAGE: 1500PCS / REEL.
- RoHS COMPLIANT.

### Description

The Hyper Red source color devices are made with DH InGaAlP on GaAs substrate Light Emitting Diode.  
The Super Bright Yellow source color devices are made with DH InGaAlP on GaAs substrate Light Emitting Diode.

### Package Dimensions

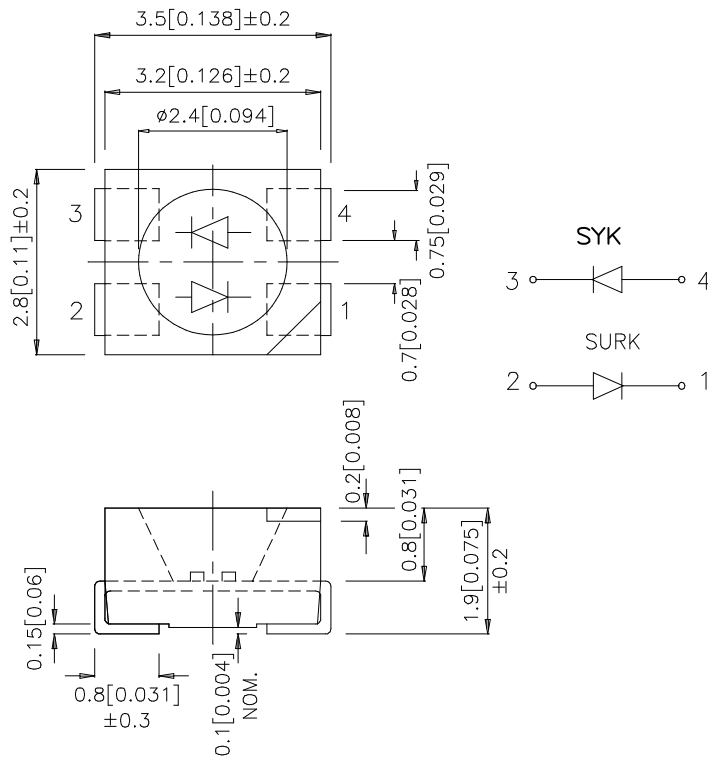

#### Notes:

1. All dimensions are in millimeters (inches).
2. Tolerance is  $\pm 0.25$  (0.01") unless otherwise noted.
3. Specifications are subjected to change without notice.

## Selection Guide

Part No.	Dice	Lens Type	Iv (mcd) @ 20mA		Viewing Angle
			Min.	Typ.	2θ1/2
KAA-3528SURKSYKC	HYPHER RED (InGaAlP)	WATER CLEAR	70	200	120°
	SUPER BRIGHT YELLOW (InGaAlP)		18	100	

Note:

1. θ1/2 is the angle from optical centerline where the luminous intensity is 1/2 the optical centerline value.

## Electrical / Optical Characteristics at TA=25°C

Symbol	Parameter	Device	Typ.	Max.	Units	Test Conditions
λ <sub>peak</sub>	Peak Wavelength	Hyper Red Super Bright Yellow	650 590		nm	I <sub>F</sub> =20mA
λ <sub>D</sub>	Dominant Wavelength	Hyper Red Super Bright Yellow	635 590		nm	I <sub>F</sub> =20mA
Δλ <sub>1/2</sub>	Spectral Line Half-width	Hyper Red Super Bright Yellow	28 20		nm	I <sub>F</sub> =20mA
C	Capacitance	Hyper Red Super Bright Yellow	35 20		pF	V <sub>F</sub> =0V;f=1MHz
V <sub>F</sub>	Forward Voltage	Hyper Red Super Bright Yellow	1.95 2.0	2.5 2.5	V	I <sub>F</sub> =20mA
I <sub>R</sub>	Reverse Current	All		10	uA	V <sub>R</sub> = 5V

## Absolute Maximum Ratings at TA=25°C

Parameter	Hyper Red	Super Bright Yellow	Units
Power dissipation	75	75	mW
DC Forward Current	30	30	mA
Peak Forward Current [1]	185	175	mA
Reverse Voltage	5		V
Operating/Storage Temperature	-40°C To +85°C		

Note:

1. 1/10 Duty Cycle, 0.1ms Pulse Width.

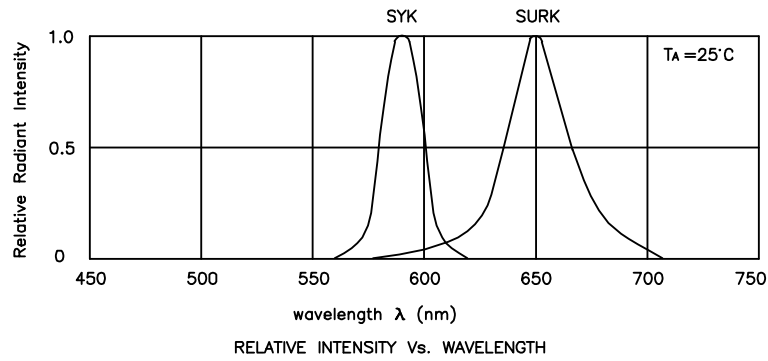

## KAA-3528SURKSYKC Hyper Red

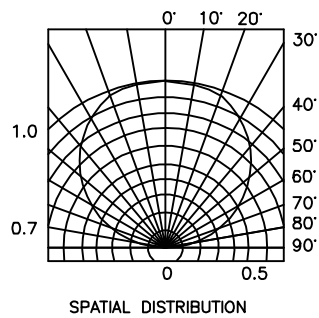
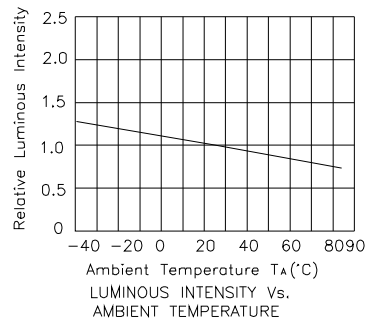
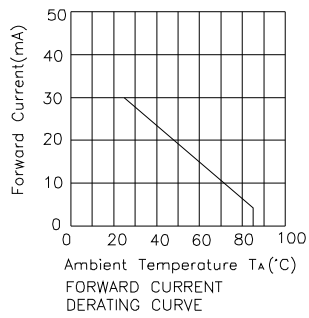
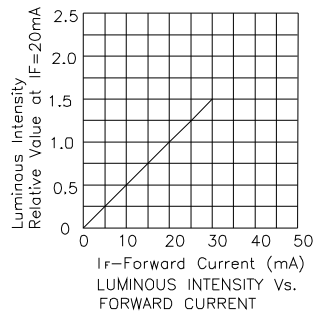
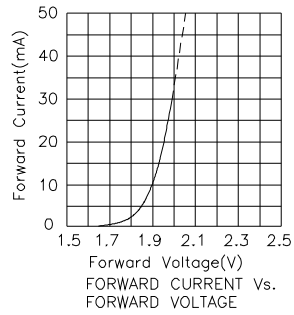

# Kingbright

## Super Bright Yellow

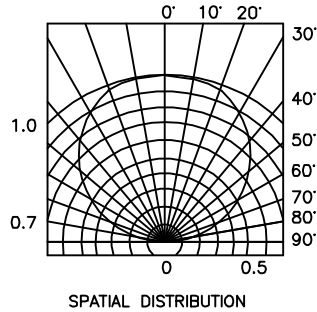
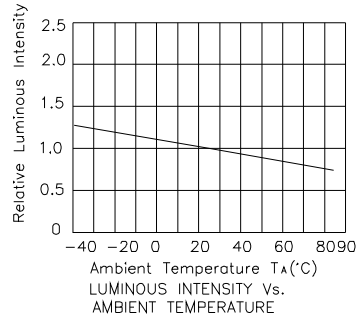
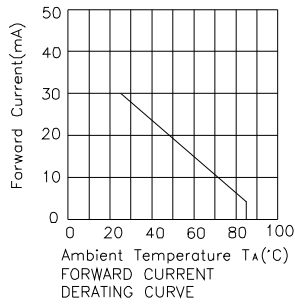
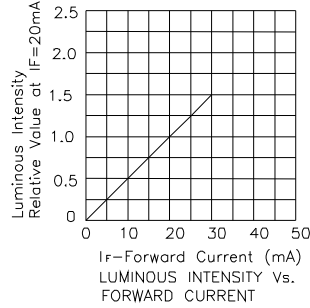
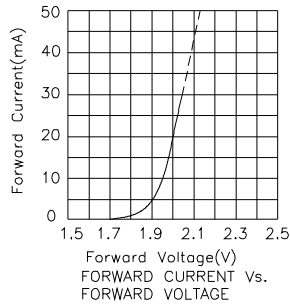

## KA A-3528SURKSYKC

Reflow Soldering Profile For Lead-free SMT Process.

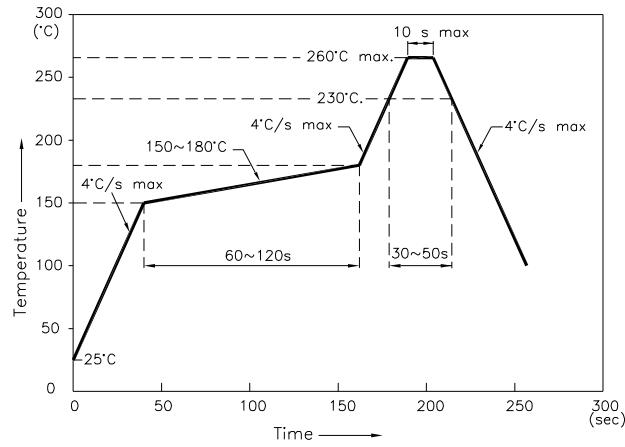

**NOTES:**

1. We recommend the reflow temperature 245°C(+/-5°C). The maximum soldering temperature should be limited to 260°C.
2. Don't cause stress to the epoxy resin while it is exposed to high temperature.
3. Number of reflow process shall be 2 times or less.

### Recommended Soldering Pattern (Units : mm)

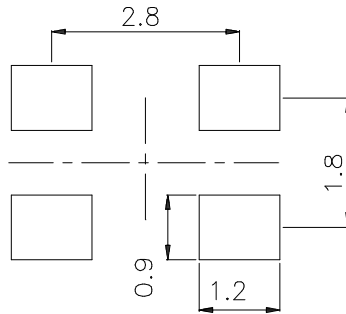

### Tape Specifications (Units : mm)

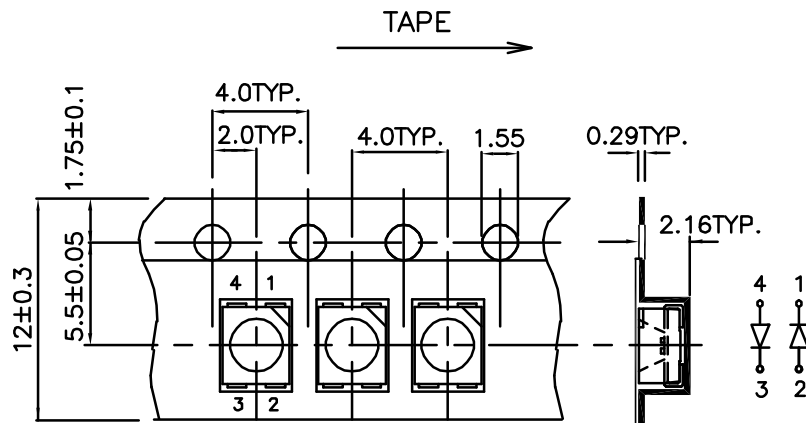

**Remarks:**

If special sorting is required (e.g. binning based on forward voltage, luminous intensity, or wavelength), the typical accuracy of the sorting process is as follows:

1. Wavelength: +/-1nm
2. Luminous Intensity: +/-15%
3. Forward Voltage: +/-0.1V

Note: Accuracy may depend on the sorting parameters.