



MICROCHIP

**PIC32 USB Starter Kit III
User's Guide**

Note the following details of the code protection feature on Microchip devices:

- Microchip products meet the specification contained in their particular Microchip Data Sheet.
- Microchip believes that its family of products is one of the most secure families of its kind on the market today, when used in the intended manner and under normal conditions.
- There are dishonest and possibly illegal methods used to breach the code protection feature. All of these methods, to our knowledge, require using the Microchip products in a manner outside the operating specifications contained in Microchip's Data Sheets. Most likely, the person doing so is engaged in theft of intellectual property.
- Microchip is willing to work with the customer who is concerned about the integrity of their code.
- Neither Microchip nor any other semiconductor manufacturer can guarantee the security of their code. Code protection does not mean that we are guaranteeing the product as "unbreakable."

Code protection is constantly evolving. We at Microchip are committed to continuously improving the code protection features of our products. Attempts to break Microchip's code protection feature may be a violation of the Digital Millennium Copyright Act. If such acts allow unauthorized access to your software or other copyrighted work, you may have a right to sue for relief under that Act.

Information contained in this publication regarding device applications and the like is provided only for your convenience and may be superseded by updates. It is your responsibility to ensure that your application meets with your specifications. MICROCHIP MAKES NO REPRESENTATIONS OR WARRANTIES OF ANY KIND WHETHER EXPRESS OR IMPLIED, WRITTEN OR ORAL, STATUTORY OR OTHERWISE, RELATED TO THE INFORMATION, INCLUDING BUT NOT LIMITED TO ITS CONDITION, QUALITY, PERFORMANCE, MERCHANTABILITY OR FITNESS FOR PURPOSE. Microchip disclaims all liability arising from this information and its use. Use of Microchip devices in life support and/or safety applications is entirely at the buyer's risk, and the buyer agrees to defend, indemnify and hold harmless Microchip from any and all damages, claims, suits, or expenses resulting from such use. No licenses are conveyed, implicitly or otherwise, under any Microchip intellectual property rights.

Trademarks

The Microchip name and logo, the Microchip logo, dsPIC, FlashFlex, KEELOQ, KEELOQ logo, MPLAB, PIC, PICmicro, PICSTART, PIC³² logo, rPIC, SST, SST Logo, SuperFlash and UNI/O are registered trademarks of Microchip Technology Incorporated in the U.S.A. and other countries.

FilterLab, Hampshire, HI-TECH C, Linear Active Thermistor, MTP, SEEVAL and The Embedded Control Solutions Company are registered trademarks of Microchip Technology Incorporated in the U.S.A.

Silicon Storage Technology is a registered trademark of Microchip Technology Inc. in other countries.

Analog-for-the-Digital Age, Application Maestro, BodyCom, chipKIT, chipKIT logo, CodeGuard, dsPICDEM, dsPICDEM.net, dsPICworks, dsSPEAK, ECAN, ECONOMONITOR, FanSense, HI-TIDE, In-Circuit Serial Programming, ICSP, Mindi, MiWi, MPASM, MPF, MPLAB Certified logo, MPLIB, MPLINK, mTouch, Omniscient Code Generation, PICC, PICC-18, PICDEM, PICDEM.net, PICkit, PICtail, REAL ICE, rLAB, Select Mode, SQI, Serial Quad I/O, Total Endurance, TSHARC, UniWinDriver, WiperLock, ZENA and Z-Scale are trademarks of Microchip Technology Incorporated in the U.S.A. and other countries.

SQTP is a service mark of Microchip Technology Incorporated in the U.S.A.

GestIC and ULPP are registered trademarks of Microchip Technology Germany II GmbH & Co. & KG, a subsidiary of Microchip Technology Inc., in other countries.

All other trademarks mentioned herein are property of their respective companies.

© 2013, Microchip Technology Incorporated, Printed in the U.S.A., All Rights Reserved.

 Printed on recycled paper.

ISBN: 978-1-62077-562-2

**QUALITY MANAGEMENT SYSTEM
CERTIFIED BY DNV
= ISO/TS 16949 =**

Microchip received ISO/TS-16949:2009 certification for its worldwide headquarters, design and wafer fabrication facilities in Chandler and Tempe, Arizona; Gresham, Oregon and design centers in California and India. The Company's quality system processes and procedures are for its PIC[®] MCUs and dsPIC[®] DSCs, KEELOQ[®] code hopping devices, Serial EEPROMs, microperipherals, nonvolatile memory and analog products. In addition, Microchip's quality system for the design and manufacture of development systems is ISO 9001:2000 certified.

Object of Declaration: PIC32 USB Starter Kit III

EU Declaration of Conformity

This declaration of conformity is issued by the manufacturer.

The development/evaluation tool is designed to be used for research and development in a laboratory environment. This development/evaluation tool is not a Finished Appliance, nor is it intended for incorporation into Finished Appliances that are made commercially available as single functional units to end users under EU EMC Directive 2004/108/EC and as supported by the European Commission's Guide for the EMC Directive 2004/108/EC (8th February 2010).

This development/evaluation tool complies with EU RoHS2 Directive 2011/65/EU.

For information regarding the exclusive, limited warranties applicable to Microchip products, please see Microchip's standard terms and conditions of sale, which are printed on our sales documentation and available at www.microchip.com.

Signed for and on behalf of Microchip Technology Inc. at Chandler, Arizona, USA

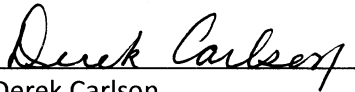

Derek Carlson
VP Development Tools

16-July-2013
Date

PIC32 USB Starter Kit III User's Guide

NOTES:



PIC32 USB STARTER KIT III USER'S GUIDE

Table of Contents

Chapter 1. Introduction

1.1 Kit Contents	13
1.2 PIC32 Functionality and Features	14

Chapter 2. Hardware

2.1 Hardware Features	17
-----------------------------	----

Appendix A. Board Layout and Schematics

A.1 PIC32 USB Starter Kit III Development Board Block Diagram	19
A.2 PIC32 USB Starter Kit III Board Layout	20
A.3 PIC32 USB Starter Kit III Board Schematics	22

Appendix B. Bill of Materials

B.1 PIC32 USB Starter Kit III Bill of Materials	27
---	----

PIC32 USB Starter Kit III User's Guide

NOTES:

Preface

NOTICE TO CUSTOMERS

All documentation becomes dated, and this manual is no exception. Microchip tools and documentation are constantly evolving to meet customer needs, so some actual dialogs and/or tool descriptions may differ from those in this document. Please refer to our web site (www.microchip.com) to obtain the latest documentation available.

Documents are identified with a “DS” number. This number is located on the bottom of each page, in front of the page number. The numbering convention for the DS number is “DSXXXXXXXXA”, where “XXXXXXXX” is the document number and “A” is the revision level of the document.

For the most up-to-date information on development tools, see the MPLAB® IDE online help. Select the Help menu, and then Topics to open a list of available online help files.

INTRODUCTION

This chapter contains general information that will be useful to know before using the starter kit. Items discussed in this chapter include:

- [Document Layout](#)
- [Conventions Used in this Guide](#)
- [Recommended Reading](#)
- [The Microchip Web Site](#)
- [Development Systems Customer Change Notification Service](#)
- [Customer Support](#)
- [Document Revision History](#)

DOCUMENT LAYOUT

This document describes how to use the PIC32 USB Starter Kit III (i.e., starter kit) as a development tool to emulate and debug firmware on a target board. This user's guide includes the following chapters:

- **Chapter 1. “Introduction”** provides a brief overview of the starter kit, highlighting its features and uses.
- **Chapter 2. “Hardware”** provides the hardware descriptions of the starter kit.
- **Appendix A. “Board Layout and Schematics”** provides a block diagram, board layouts, and detailed schematics of the starter kit.
- **Appendix B. “Bill of Materials”** provides the bill of material descriptions and the reference, manufacturer, and part numbers for the components used in the starter kit hardware.

PIC32 USB Starter Kit III User's Guide

CONVENTIONS USED IN THIS GUIDE

This manual uses the following documentation conventions:

DOCUMENTATION CONVENTIONS

Description	Represents	Examples
Italic characters	Referenced books	<i>MPLAB IDE User's Guide</i>
	Emphasized text	...is the <i>only</i> compiler...
Initial caps	A window	the Output window
	A dialog	the Settings dialog
	A menu selection	select Enable Programmer
Quotes	A field name in a window or dialog	"Save project before build"
Underlined, italic text with right angle bracket	A menu path	<u><i>File > Save</i></u>
Bold characters	A dialog button	Click OK
	A tab	Click the Power tab
Text in angle brackets < >	A key on the keyboard	Press <Enter>, <F1>
Plain Courier New	Sample source code	#define START
	Filenames	autoexec.bat
	File paths	c:\mcc18\h
	Keywords	_asm, _endasm, static
	Command-line options	-Opa+, -Opa-
	Bit values	0, 1
	Constants	0xFF, 'A'
<i>Italic Courier New</i>	A variable argument	<i>file.o</i> , where <i>file</i> can be any valid filename
Square brackets []	Optional arguments	mcc18 [options] <i>file</i> [options]
Curly brackets and pipe character: { }	Choice of mutually exclusive arguments; an OR selection	errorlevel {0 1}
Ellipses...	Replaces repeated text	var_name [, var_name...]
	Represents code supplied by user	void main (void) { ... }
Notes	A Note presents information that we want to re-emphasize, either to help you avoid a common pitfall or to make you aware of operating differences between some device family members. A Note can be in a box, or when used in a table or figure, it is located at the bottom of the table or figure.	Note: This is a standard note box.
		CAUTION This is a caution note. Note 1: This is a note used in a table.

RECOMMENDED READING

This user's guide describes how to use the starter kit. The following Microchip documents are available and recommended as supplemental reference resources.

PIC32MX330/350/370/430/450/470 Family Data Sheet (DS60001185)

Consult this document for detailed information on PIC32 devices. Reference information found in this data sheet includes:

- Device memory maps
- Device pinout and packaging details
- Device electrical specifications
- List of peripherals included on the devices

MPLAB[®] XC32 C/C++ Compiler User's Guide (DS50001686)

This document details the use of Microchip's MPLAB XC32 C/C++ Compiler to develop an application.

MPLAB[®] X IDE User's Guide (DS50002027)

Refer to this document for more information pertaining to the installation and implementation of the MPLAB X IDE software, as well as the MPLAB SIM Simulator software that is included with it.

Universal Serial Bus Specification and Associated Documents

The Universal Serial Bus is defined by the USB 2.0 specification and its associated supplements and class-specific documents. These documents are available from the USB Implementers Forum. See their web site at: <http://www.usb.org>

THE MICROCHIP WEB SITE

Microchip provides online support via our web site at: <http://www.microchip.com>. This web site makes files and information easily available to customers. Accessible by most Internet browsers, the web site contains the following information:

- **Product Support** – Data sheets and errata, application notes and sample programs, design resources, user's guides and hardware support documents, latest software releases and archived software
- **General Technical Support** – Frequently Asked Questions (FAQs), technical support requests, online discussion groups, Microchip consultant program member listings
- **Business of Microchip** – Product selector and ordering guides, latest Microchip press releases, listings of seminars and events; and listings of Microchip sales offices, distributors and factory representatives

PIC32 USB Starter Kit III User's Guide

DEVELOPMENT SYSTEMS CUSTOMER CHANGE NOTIFICATION SERVICE

Microchip's customer notification service helps keep customers current on Microchip products. Subscribers will receive e-mail notification whenever there are changes, updates, revisions or errata related to a specified product family or development tool of interest.

To register, access the Microchip web site at www.microchip.com, click on Customer Change Notification and follow the registration instructions.

The Development Systems product group categories are:

- **Compilers** – The latest information on Microchip C compilers and other language tools
- **Emulators** – The latest information on the Microchip in-circuit emulator, MPLAB REAL ICE™
- **In-Circuit Debuggers** – The latest information on the Microchip in-circuit debugger, MPLAB ICD 3
- **MPLAB X IDE** – The latest information on Microchip MPLAB X IDE, the Windows® Integrated Development Environment for development systems tools
- **Programmiers** – The latest information on Microchip programmers including the PICkit™ 3 development programmer

CUSTOMER SUPPORT

Users of Microchip products can receive assistance through several channels:

- Distributor or Representative
- Local Sales Office
- Field Application Engineer (FAE)
- Technical Support

Customers should contact their distributor, representative or field application engineer (FAE) for support. Local sales offices are also available to help customers. A listing of sales offices and locations is included in the back of this document.

Technical support is available through the web site at: <http://support.microchip.com>

DOCUMENT REVISION HISTORY

Revision A (June 2013)

This is the initial release of the PIC32 USB Starter Kit III User's Guide.

Revision B (October 2013)

The PIC32 device was updated to the PIC32MX470F512L. All updates in this revision reflect this change throughout the document.

PIC32 USB Starter Kit III User's Guide

NOTES:

Chapter 1. Introduction

Thank you for purchasing the Microchip Technology Inc. PIC32 USB Starter Kit III. This board provides a low-cost, modular development system for Microchip's line of 32-bit microcontrollers.

The starter kit is preloaded with demonstration software for the user to explore the new features of the PIC32. It is also expandable through a modular expansion interface, which allows the user to extend its functionality. The starter kit also supplies on-board circuitry for full debug and programming capabilities.

This chapter covers the following topics:

- [Kit Contents](#)
- [PIC32 Functionality and Features](#)

The preprogrammed example code on the PIC32 MCU is available for download from the Microchip web site at <http://www.microchip.com>. All project files have been included so that the code may be used directly to restore the PIC32 MCU on the starter kit to its original state (i.e., if the sample device has been reprogrammed with another program).

1.1 KIT CONTENTS

The PIC32 USB Starter Kit III contains the following items:

- PIC32 USB Starter Kit III Development Board
- USB mini-B to full-sized A cable – USB debug cable to debug and power the board
- USB micro-B to full-sized A cable – PIC32 USB cable to communicate with the PIC32 USB port

Note: If you are missing any part of a kit, contact a Microchip sales office for assistance. A list of Microchip offices for sales and service is provided at the end of this document.

PIC32 USB Starter Kit III User's Guide

1.2 PIC32 FUNCTIONALITY AND FEATURES

Representations of the layout of the PIC32 USB Starter Kit III are shown in [Figure 1-1](#) and [Figure 1-2](#).

The top assembly of the board includes these key features, as indicated in [Figure 1-1](#):

1. PIC32MX470F512L 32-bit microcontroller (U1).
2. Green power indicator LED (D7).
3. On-board crystal (Y1) for precision microcontroller clocking (8 MHz).
4. USB Type mini-B receptacle for on-board debugger communications (J3).
5. Green PICkit™ On-board (PKOB) debug indicator LED (D6).
6. Three push button switches, SW1, SW2, and SW3, for user-defined inputs (S1, S2, S3).
7. Three user-defined indicator LEDs, LED1, LED2, and LED3 (D3, D4, D5).
8. USB Type A receptacle for PIC32 host-based applications (J5).
9. HOST mode power jumper (JP1).
10. Regulated +3.3V power supply for powering the starter kit via USB or expansion board (U3).

Note: When running USB device applications, open the jumper JP1 to prevent possibly back-feeding voltage onto the VBUS from one port on the host to another (or from one host to another).

FIGURE 1-1: PIC32 USB STARTER KIT III LAYOUT (TOP VIEW)

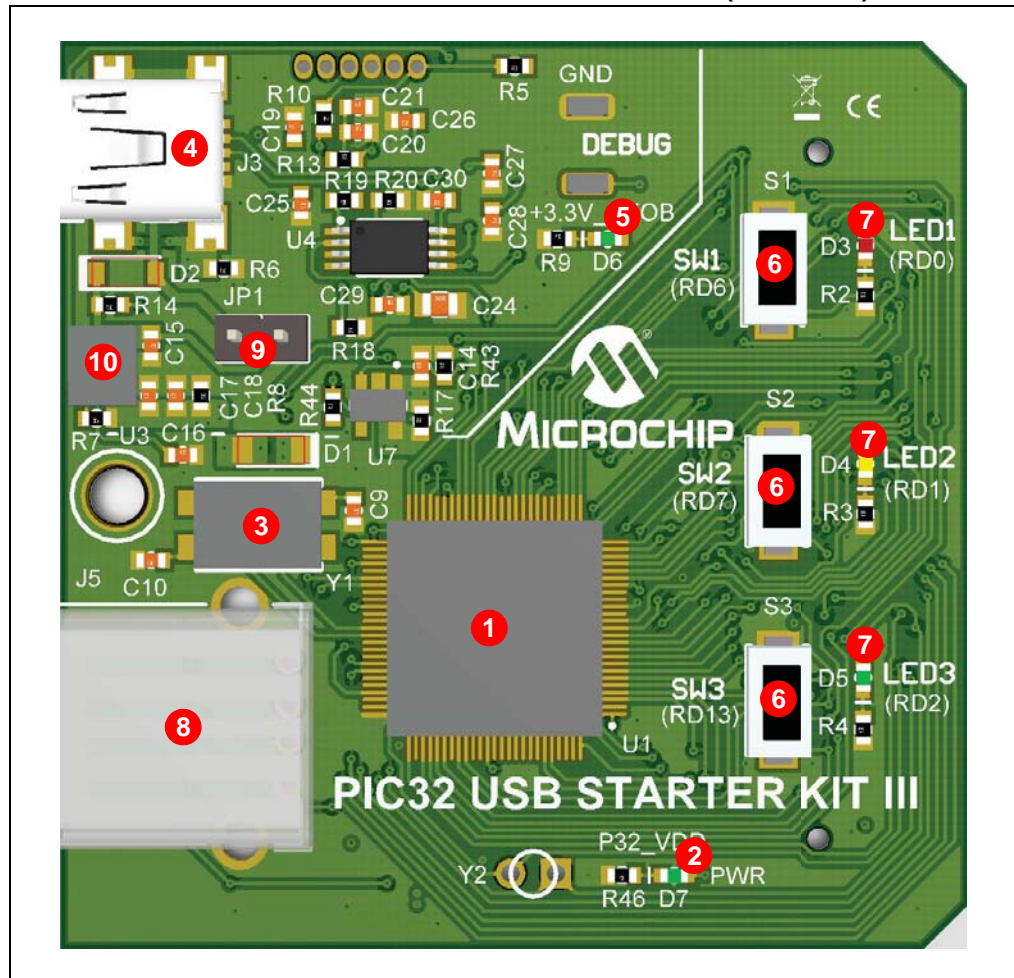

The bottom assembly of the board includes these key features, as indicated in [Figure 1-2](#):

1. PIC24FJ256GB106 for PKOB debugging (U2).
2. Connector for various expansion boards (J1).
3. USB Host and OTG power supply for powering PIC32 USB applications (U5).
4. USB Type Micro-AB receptacle for OTG and USB device connectivity for PIC32 OTG/device-based applications (J4).

FIGURE 1-2: PIC32 USB STARTER KIT III LAYOUT (BOTTOM VIEW)

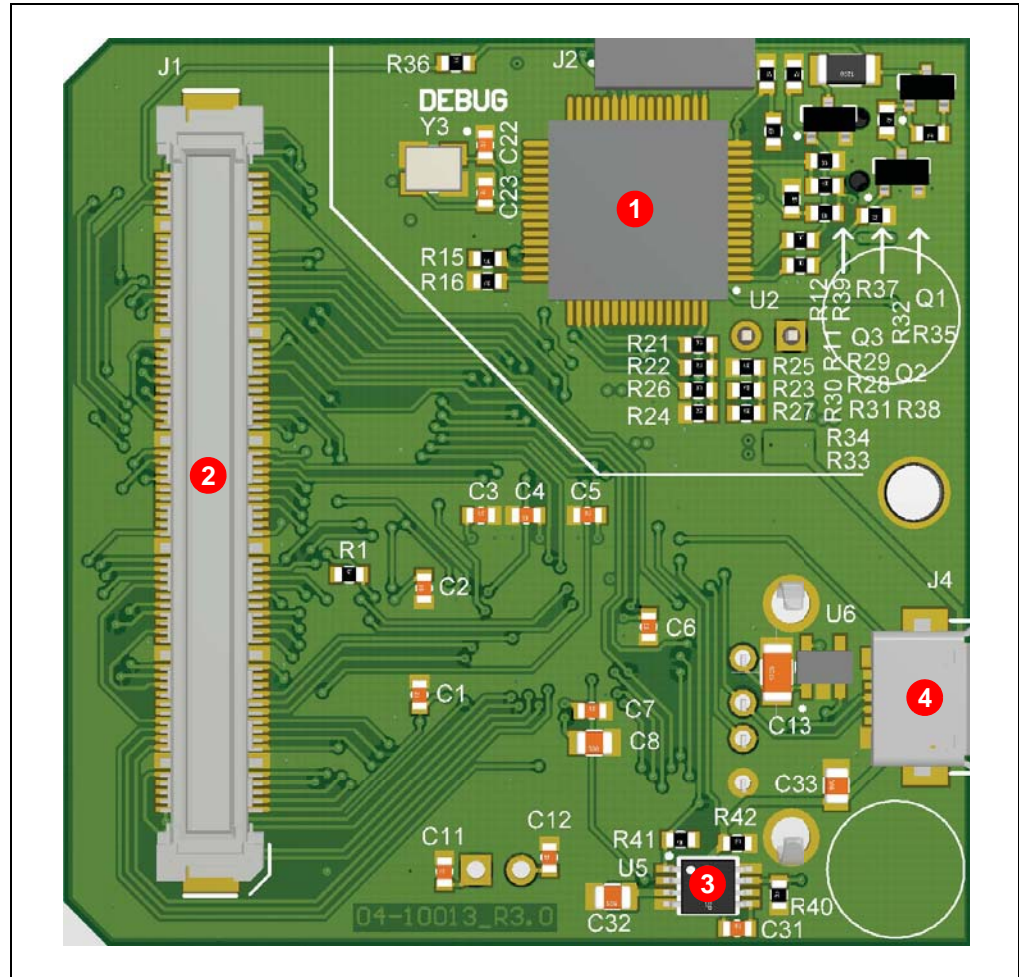

PIC32 USB Starter Kit III User's Guide

NOTES:

Chapter 2. Hardware

This chapter describes the hardware features of the starter kit.

2.1 HARDWARE FEATURES

The key features of the PIC32 USB Starter Kit III are listed below. They are presented in the same order as described in [Section 1.2 “PIC32 Functionality and Features”](#). You can refer to [Figure 1-1](#) for their locations on the board.

2.1.1 Processor Support

The PIC32 USB Starter Kit III is designed with a permanently mounted (i.e., soldered) PIC32MX470F512L processor.

2.1.2 Power Supply

There are two ways to supply power to the PIC32 USB Starter Kit III:

- USB bus power connected to the USB debug connector, J3
- An external application board with a regulated DC power supply that provides +5V can be connected to the J1 application board connector that is provided on the bottom side of the board

One green LED, PWR (D7), is provided to indicate the PIC32 microcontroller is powered.

2.1.3 Debug USB Connectivity

The PIC32 USB Starter Kit III includes a PIC24FJ256GB106 that provides debugger connectivity over USB PKOB. The PIC24FJ256GB106 is hard-wired to the PIC32 device to provide protocol translation through the I/O pins of the PIC24FJ256GB106 to the ICSP™ pins of the PIC32 device.

The PIC32 USB Starter Kit III currently uses the ICSP pins of the PIC32 device for programming and debugging.

2.1.4 PIC32 USB Connectivity

The following are three possible ways to connect to the PIC32MX470F512L:

- HOST mode – Connect the device to the Type A connector J5, which is located on the top side of the starter kit. If using the Debug USB port to power the Host port, install jumper JP1 to short the back-power prevention diode. Note that a maximum of ~400 mA can be supplied from the Debug USB port to the Host port using this method. If full 500 mA supply is needed, an external supply must be connected to the application board, and the jumper JP1 must be removed to prevent back-powering the Debug USB port.

PIC32 USB Starter Kit III User's Guide

- **DEVICE mode** – Connect the debug Mini-B USB cable to port J3 and this cable will be plugged into the Host USB port to provide power and for debugging, if necessary. Then connect the starter kit to the Host using a cable with a Type-B Micro connector to the starter kit's Micro A/B port J4, located on the bottom side of the starter kit. Connect the other end of this cable to the Host for the DEVICE mode communication. Jumper JP1 should be removed.
- **OTG mode** – Connect the starter kit to the OTG device using an OTG Micro A/B cable to the Micro A/B port J4, located on the bottom side of the starter kit. The starter kit provides an on-board power supply capable of providing 120 mA (maximum). This supply is controlled by the PIC32MX470F512L microcontroller. Jumper JP1 should be removed.

2.1.5 Switches

Three push button switches provide the following functionality:

- SW1: Active-low switch connected to RD6
- SW2: Active-low switch connected to RD7
- SW3: Active-low switch connected to RD13

These switches do not have any debounce circuitry and require the use of internal pull-up resistors, which allows the investigation of software debounce techniques. When idle, the switches are pulled high (+3.3V), and when pressed, they are grounded.

2.1.6 LEDs

The three LEDs, LED1, LED2, and LED3, are connected to RD0, RD1, and RD2 of PORTD of the processor. The PORTD pins are set high to illuminate the LEDs.

2.1.7 Oscillator Options

The installed microcontroller has an oscillator circuit connected to it. The main oscillator uses an 8 MHz crystal (Y1) and functions as the controller's Primary Oscillator. Use of an external crystal is required to develop USB applications. The USB specification dictates a frequency tolerance of +/- 0.25% for full speed. Non-USB applications can use the internal oscillators. The starter kit also has provisions for an external Secondary Oscillator (Y2); however, this is not populated.

The PIC24FJ256GB106 is independently clocked and has its own 12 MHz crystal (Y3).

2.1.8 120-Pin Modular Expansion Connector

The PIC32 USB Starter Kit III is designed with a 120-pin modular expansion interface, which allows the board to provide basic generic functionality now, and easy extendability to new technologies as they become available.

TABLE 2-1: STARTER KIT CONNECTOR PART NUMBERS

Connector	HIROSE Electric PN
Starter Kit Connector	FX10A-120P/12-SV1(71)
Application Board Connector	FX10A-120S/12-SV(71)

Appendix A. Board Layout and Schematics

A.1 PIC32 USB STARTER KIT III DEVELOPMENT BOARD BLOCK DIAGRAM

FIGURE A-1: HIGH-LEVEL BLOCK DIAGRAM OF THE PIC32 USB STARTER KIT III BOARD

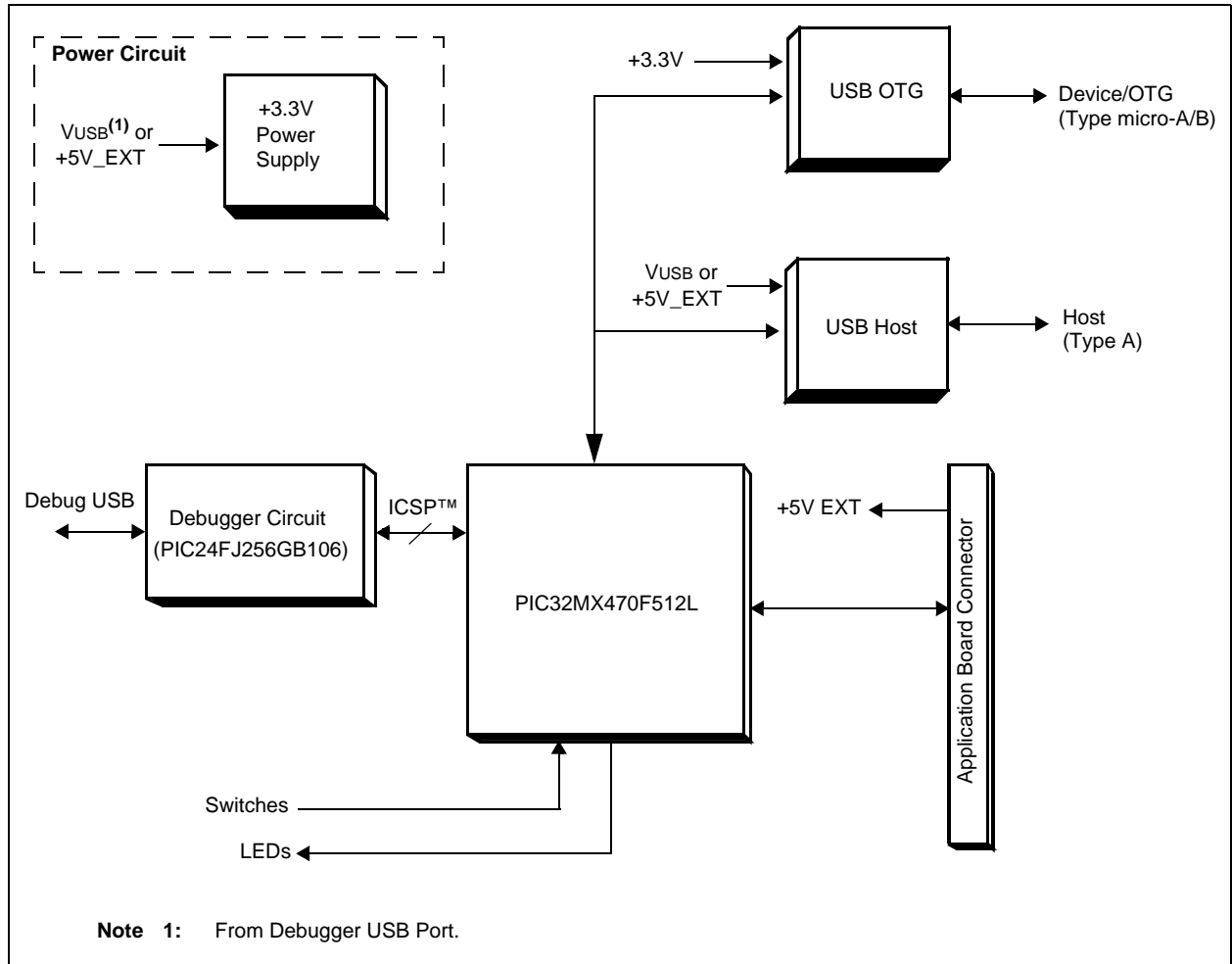

PIC32 USB Starter Kit III User's Guide

A.2 PIC32 USB STARTER KIT III BOARD LAYOUT

FIGURE A-2: PIC32 USB STARTER KIT III LAYOUT (TOP ASSEMBLY)

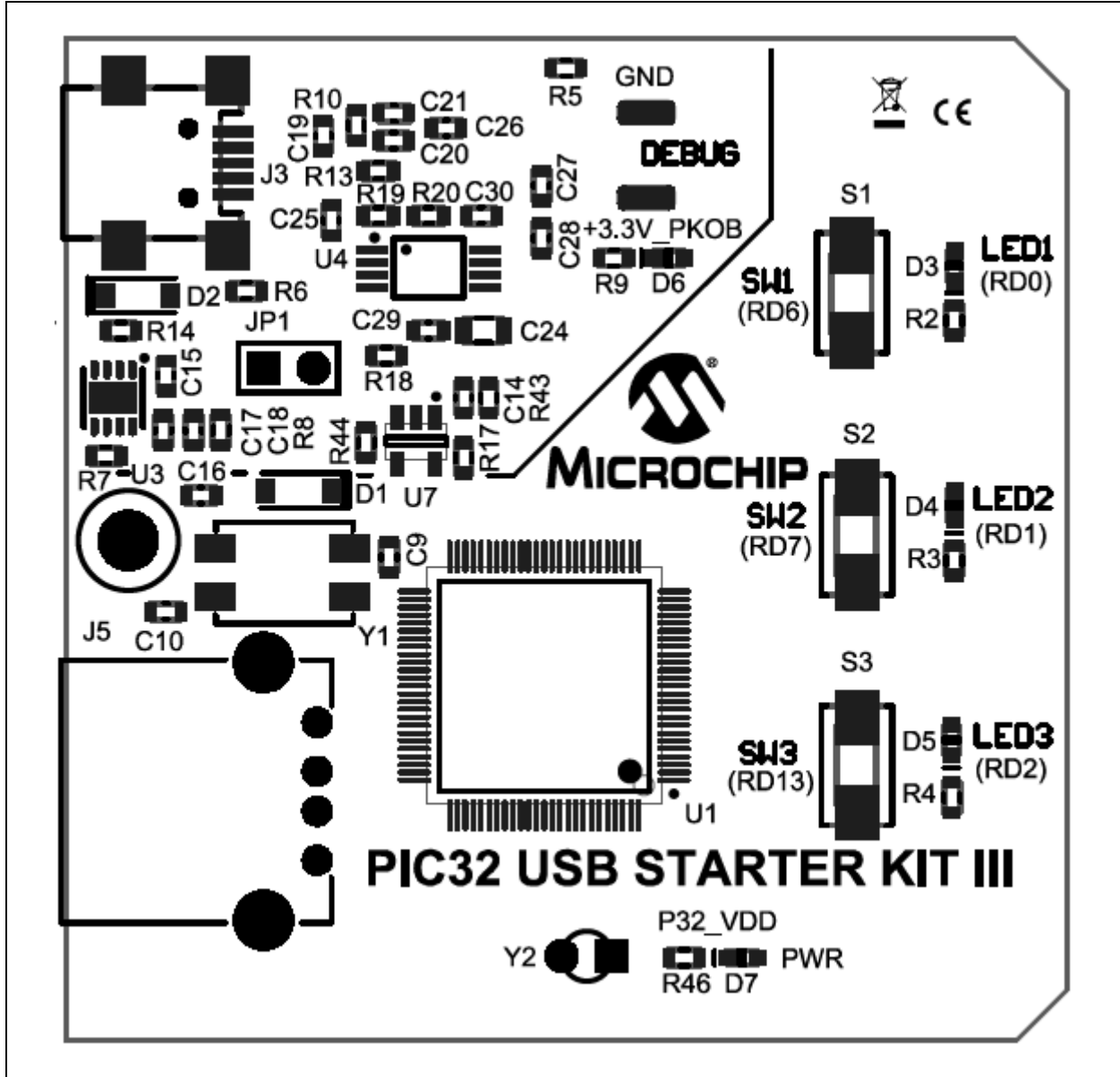
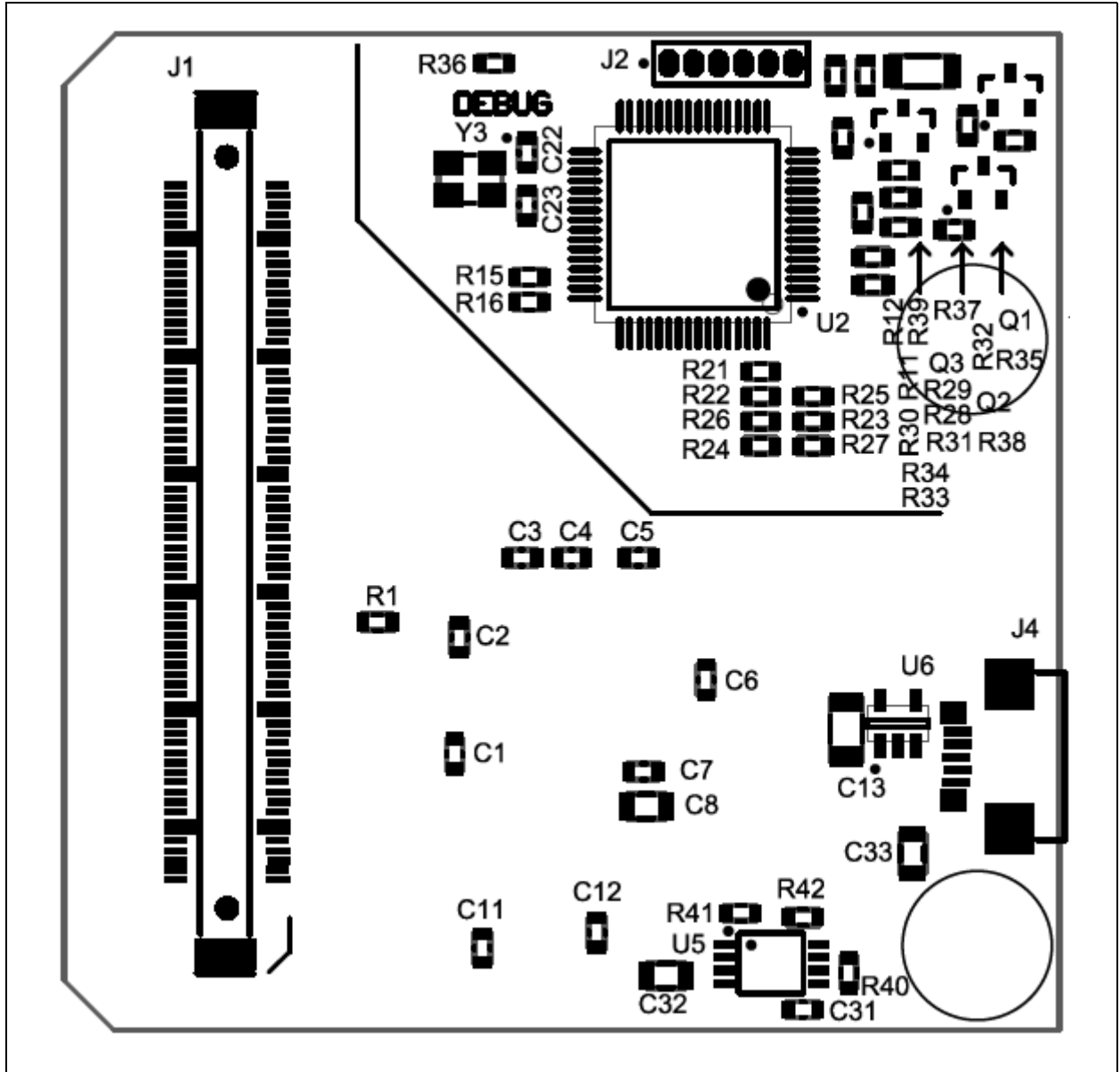

FIGURE A-3: PIC32 USB STARTER KIT III LAYOUT (BOTTOM ASSEMBLY)



PIC32 USB Starter Kit III User's Guide

A.3 PIC32 USB STARTER KIT III BOARD SCHEMATICS

FIGURE A-4: PIC32 USB STARTER KIT III SCHEMATICS (PIC32MX CPU)

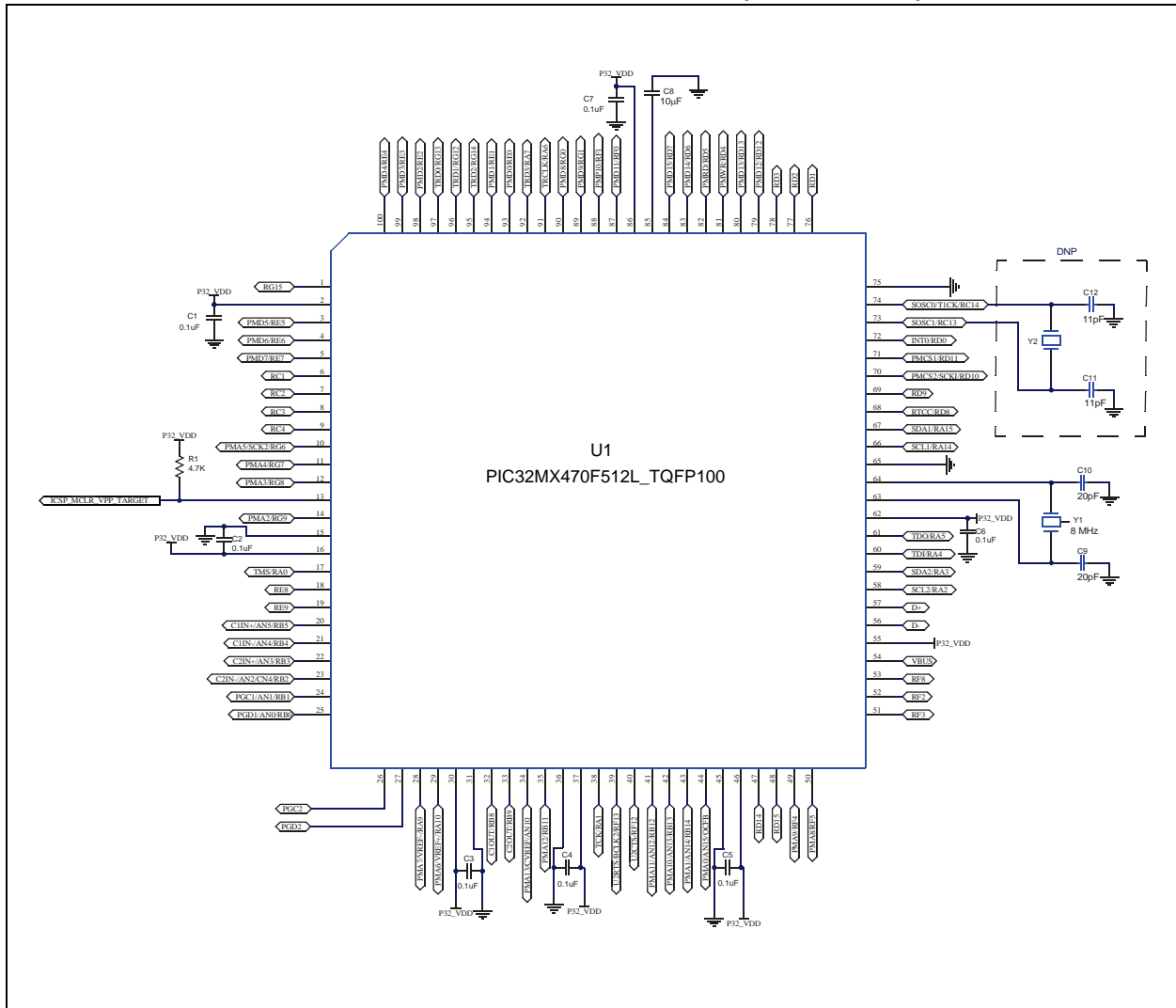
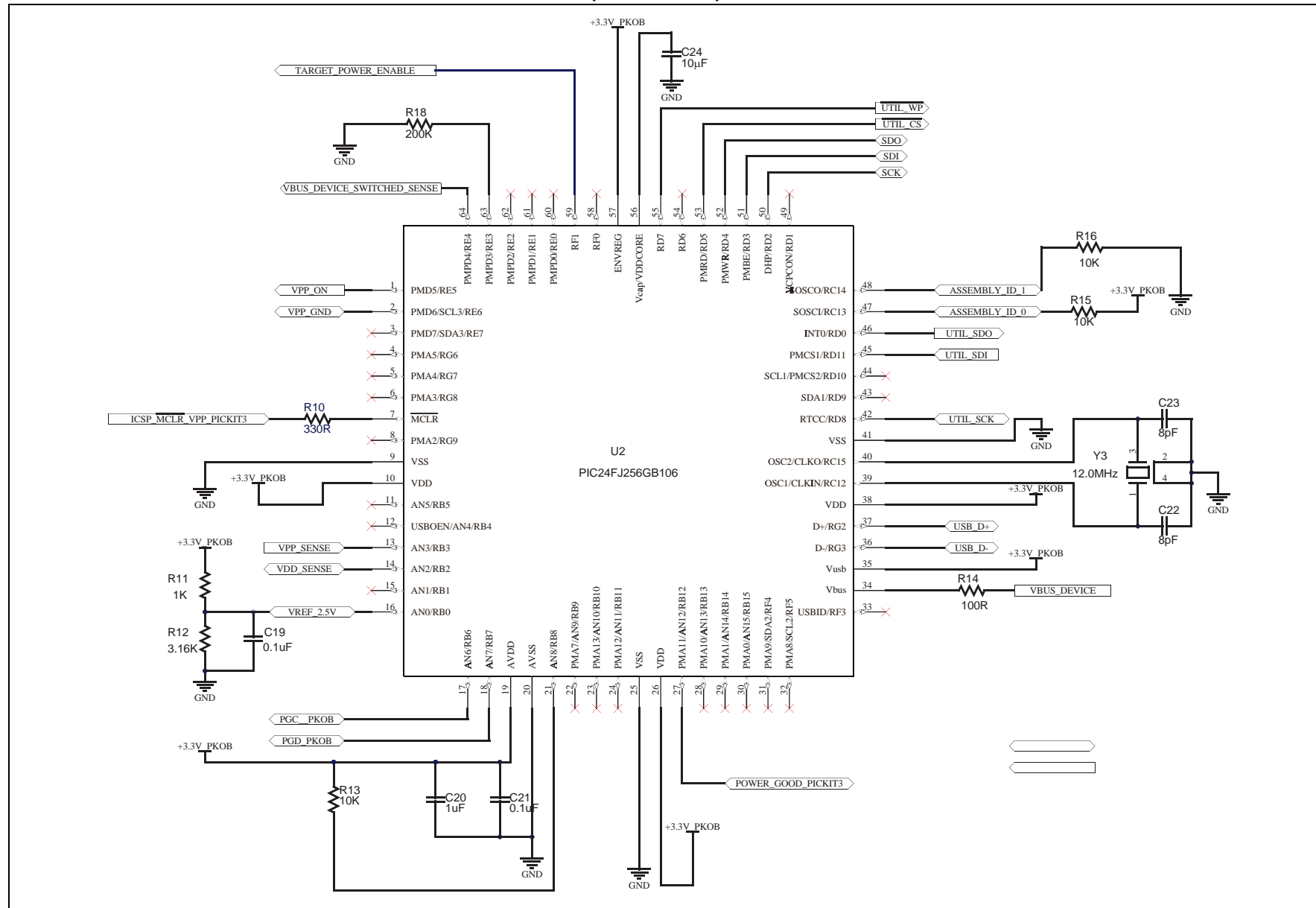

FIGURE A-5: PIC32 USB STARTER KIT III SCHEMATICS (DEBUG CPU)



PIC32 USB Starter Kit III User's Guide

FIGURE A-6: PIC32 USB STARTER KIT III SCHEMATICS (APPLICATION BOARD CONNECTOR)

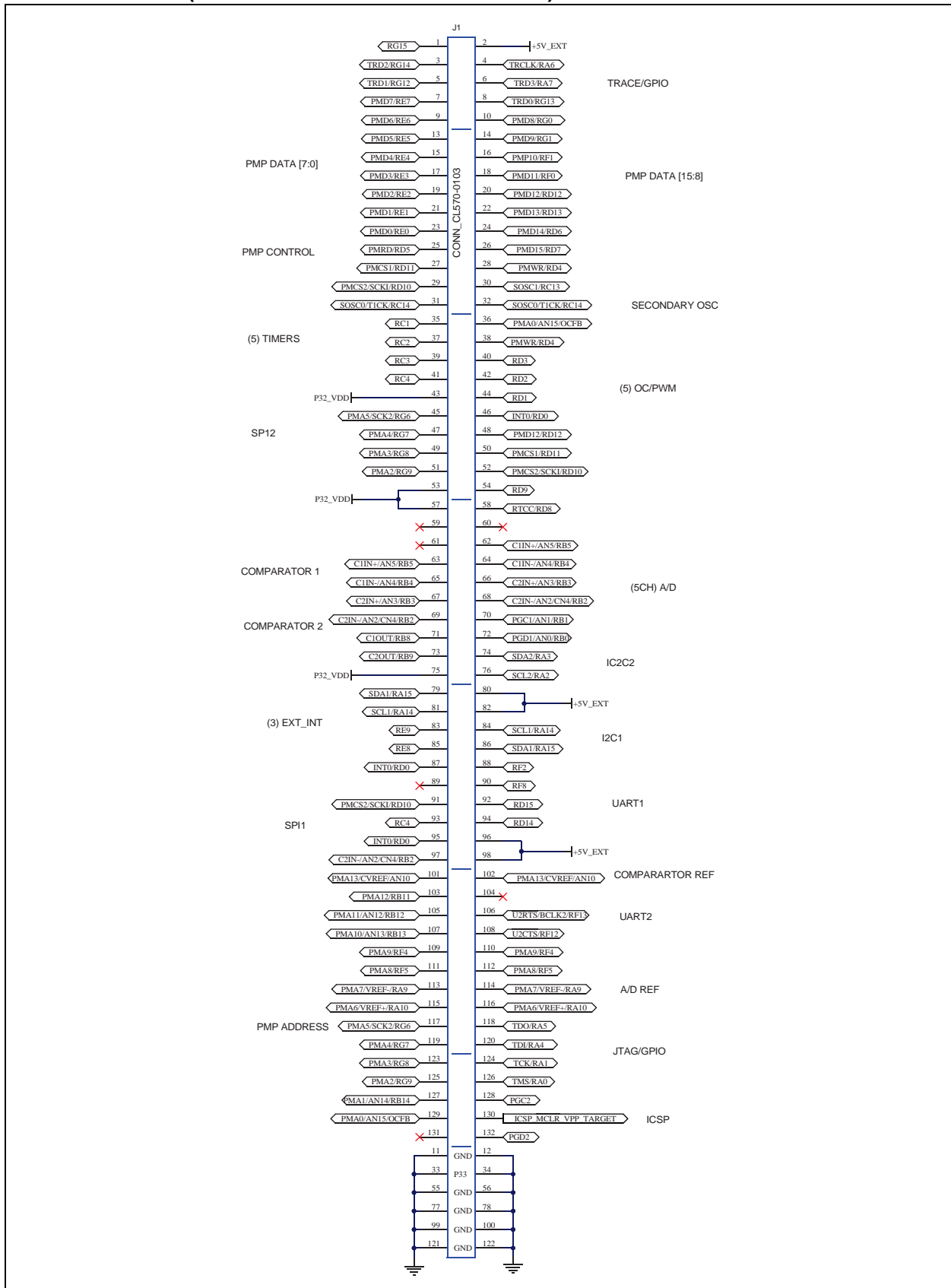

FIGURE A-7: PIC32 USB STARTER KIT III SCHEMATICS (POWER SUPPLY)

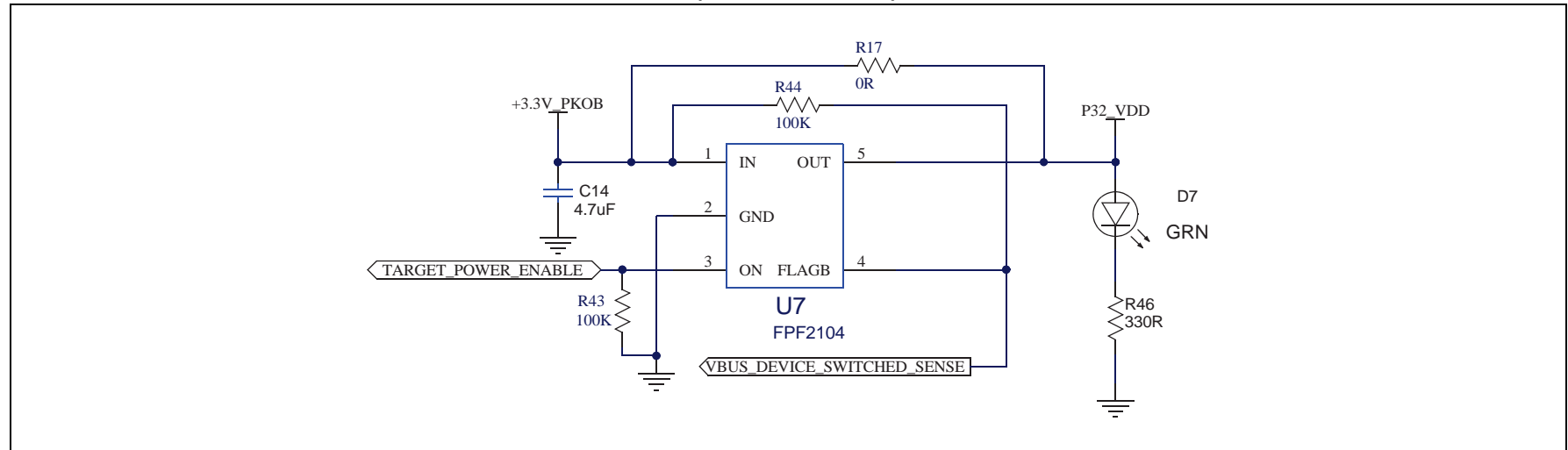

FIGURE A-8: PIC32 USB STARTER KIT III SCHEMATICS (USB OTG/DEVICE POWER SUPPLY)

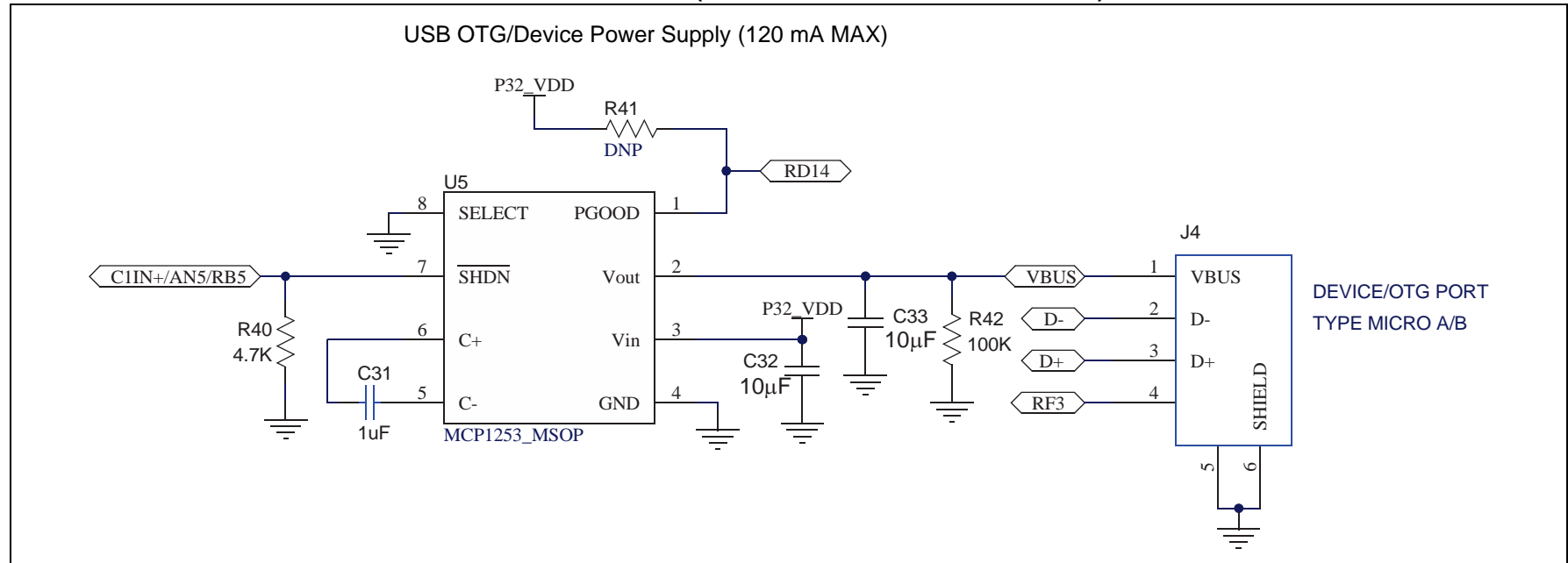

FIGURE A-9: PIC32 USB STARTER KIT III SCHEMATICS (USB HOST POWER SUPPLY)

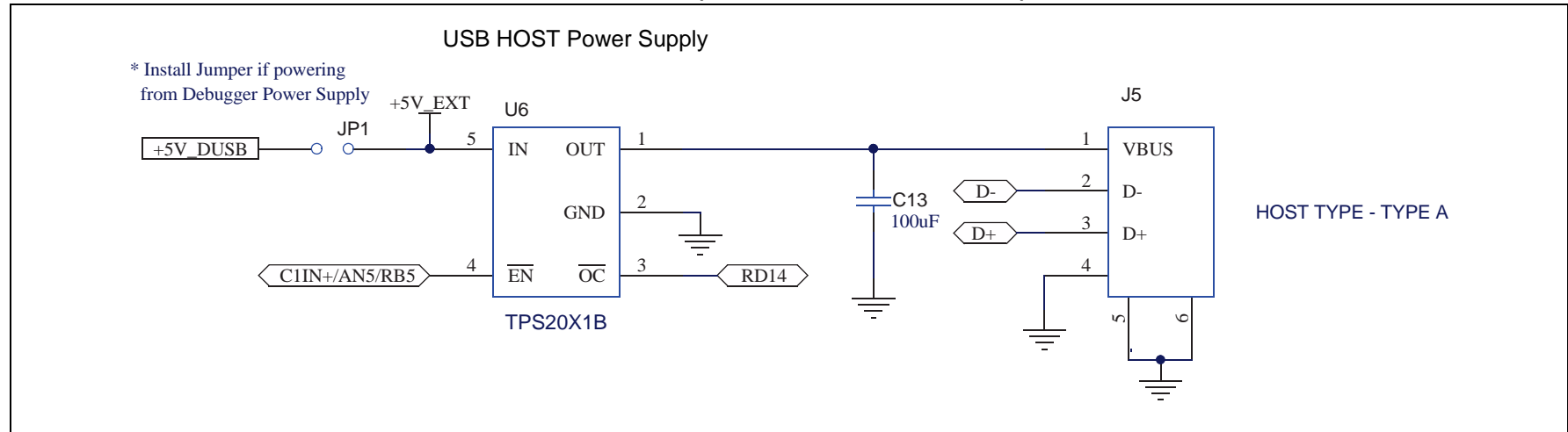
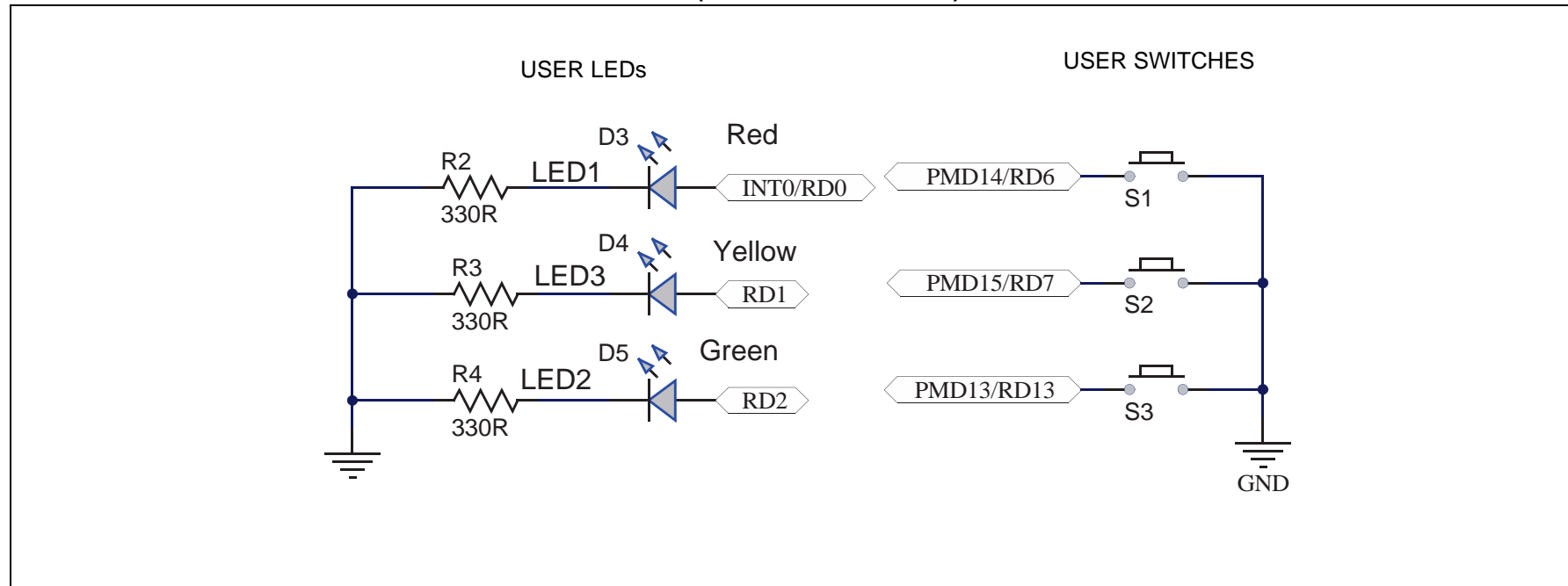

FIGURE A-10: PIC32 USB STARTER KIT III SCHEMATICS (SWITCHES AND LEDS)



Appendix B. Bill of Materials

B.1 PIC32 USB STARTER KIT III BILL OF MATERIALS

TABLE B-1: PIC32 USB STARTER KIT III BILL OF MATERIALS

Reference	Description	Manufacturer	Part No.
C1, C2, C3, C4, C5, C6, C7, C16, C19, C21, C25, C26, C27, C28, C29	CAP CER .10 μ F 50V X7R 0603	TDK Corporation	C1608X7R1H104M
C9, C10	CAP CER 20 PF 50V 5% NP0 0603	TDK Corporation	C1608C0G1H200J
C15, C17	CAP CER 2.2 μ F 16V X5R 0603	TDK Corporation	C1608X5R1C225K
C18	CAP CER 10000 pF 50V X7R 0603	TDK Corporation	C1608X7R1H103M
C20, C30, C31	CAP CER 1.0 μ F 16V X5R 10% 0603	TDK Corporation	C1608X5R1C105K
C22, C23	CAP CER 8 pF 50V NP0 0603	Murata Electronics North America	GRM1885C1H8R0DZ01D
C8, C24, C32, C33	CAP CER 10 μ F 16V Y5V 0805	Murata Electronics North America	GRM21BF51C106ZE15L
C14	CAP CER 4.7 μ F 10V Y5V 0603	Taiyo Yuden	JMK107BJ475KA-T
C13	CAP CER 100 μ F 6.3V Y5V 1206	Murata Electronics North America	GRM31CF50J107ZE01L
R1, R24, R25, R40	RES 4.7 K Ω 1/10W 1% 0603 SMD	Stackpole Electronics Inc.	RMCF0603FT4K70
R2, R3, R4, R9, R10, R21, R22, R23, R46	RES 330 Ω 1/10W 1% 0603 SMD	Stackpole Electronics Inc.	RMCF0603FT330R
R5, R13, R15, R16, R19, R31, R32, R33, R34	RES 10 K Ω 1/10W 1% 0603 SMD	Stackpole Electronics Inc.	RMCF0603FT10K0
R6, R26, R27, R36	RES 0.0 Ω 1/10W 0603 SMD	Panasonic - ECG	ERJ-3GEY0R00V
R7, R18	RES 200 K Ω 1/10W 1% 0603 SMD	Stackpole Electronics Inc.	RMCF0603FT200K
R11	RES 1 K Ω 1/10W 1% 0603 SMD	Stackpole Electronics Inc.	RMCF0603FT1K00
R12	RES 3.16 K Ω 1/10W 1% 0603 SMD	Yageo	RC0603FR-073K16L
R14	RES 100 Ω 1/10W 5% 0603 SMD	Yageo	RC0603JR-07100RL
R20, R29, R30	RES 2.21 K Ω 1/10W 1% 0603 SMD	Panasonic - ECG	ERJ-3EKF2211V
R28	RES 3.92 K Ω 1/10W 1% 0603 SMD	Yageo	RC0603FR-073K92L
R35, R42, R43, R44	RES 100 K Ω 1/10W 1% 0603 SMD	Stackpole Electronics Inc.	RMCF0603FT100K
R37	RES 100 Ω 1/4W 1% 1206 SMD	Yageo	RC1206FR-07100RL
D1, D2	DIODE SCHOTTKY 20V 0.5A SOD123	ON Semiconductor	MBR0520LT1G

PIC32 USB Starter Kit III User's Guide

TABLE B-1: PIC32 USB STARTER KIT III BILL OF MATERIALS (CONTINUED)

Reference	Description	Manufacturer	Part No.
D3	LED, SMD, RED, 0603 package	Kingbright Corp.	APT1608EC
D4	LED, SMD, YEL, 0603 package	Kingbright Corp.	APT1608YC
D5, D6, D7	LED, SMD, GRN, 0603 package	Kingbright Corp.	APT1608SGC
J1	CONN_CL570-0103	Hirose Electric Co. Ltd.	FX10B-120P/12-SV1(71)
J3	CONN RECEPT MINI USB 2.0 5 POS	Hirose Electric Co. Ltd.	UX60-MB-5ST
J4	CONN RCPT MICRO USB AB SMD R/A	Hirose Electric Co. Ltd.	ZX62-AB-5PA(11)
J5	CONN USB TYPE A R/A BLACK	On Shore Technology Inc.	USB-A1HSB6
JP1	CONN HEADER .100 SINGL STR 2 POS	Sullins	PBC02SAAN
Q1	TRANS SS PNP 40V 300 MW SOT23	Micro Commercial Co.	MMBT3906-TP
Q2, Q3	TRANSISTOR NPN GP 40V SOT23	Micro Commercial Co.	MMBT3904-TP
S1, S2, S3	SWITCH TACTILE SPST-NO 0.05A 12V	C&K Electronics	PTS635SK25SMTR LFS
U1	PIC32MX470F512L-I/PT	Microchip Technology Inc.	PIC32MX470F512L-I/PT
U2	IC PIC MCU FLASH 256K 64-pin TQFP	Microchip Technology Inc.	PIC24FJ256GB106-I/PT
U3	IC REG LDO 1.5A 3.3V 8DFN	Microchip Technology Inc.	MCP1727-3302E/MF
U4	IC EEPROM 256 kilobit 10 MHz 8 TSSOP	Microchip Technology Inc.	25LC256-I/ST
U5	IC MULT CONFIG 3.3/5V .12A 8 MSOP	Microchip Technology Inc.	MCP1253-33X50I/MS
U6	IC PWR DIST SWITCH SNGL SOT23-5	Texas Instruments	TPS2051BDBVR
U7	IC SWITCH LOAD FULL FUNC SOT23-5	Fairchild	FPF2104
Y1	CRYSTAL 8 MHz 20 pF SMD	Fox Electronics	FQ7050B-8
Y3	CRYSTAL 12 MHz 8 PF SMD	NDK	NX3225SA-12.000000 MHZ
+3.3V_PKOB, GND	PC TEST POINT MINIATURE SMT	Keystone Electronics	5015
"Feet"	BUMPON CYLINDRICAL .375X.135 BLK	3M	SJ61A8
C11, C12 (DNP)	CAP CER 11PF 50V 5% NP0 0603	TDK Corporation	C1608C0G1H110J
Y2 (DNP)	CRYSTAL 32 kHz 12.5 pF CYL	ECS Inc.	ECS-.320-12.5-13X
MH1 (DNP)	0.120 Diameter hole, unplated	DNP	DNP (120 mm unplated hole)
J2 (DNP)	CONN HEADER .050" 6 POS PCB GOLD	SULLINS	GRPB061VWVN-RC
R8, R17, R38, R39, R41 (DNP)	RES0603 DNP	DNP	DNP (RES0603)



PIC32 USB STARTER KIT III USER'S GUIDE

Index

C		U	
Customer Change Notification Service	10	USB	
Customer Support	10	Connectivity	17
D		W	
Documentation		WWW Address	9
Conventions	8		
H			
Hardware Features			
LEDs	17, 18		
Oscillator Options	18		
PICtail Plus Card Edge Connectors	18		
Power Supply	17		
Processor Support	17		
Switches	18		
USB Connectivity	17		
I			
Internet Address	9		
M			
Microchip Internet Web Site	9		
P			
PIC32			
Layout			
32-bit Microcontroller	14		
Connector for Expansion Boards	14		
Debug Indicator LED	14		
Expansion Board Connector	15		
HOST mode power jumper	14		
On-Board Crystal	14		
Power Indicator LED	14		
Power Supply	14		
Switches	14		
USB Connectivity	14		
USB Host and OTG Power Supply	15		
USB Microcontroller	15		
USB Type A Receptacle	14		
USB Type Micro-AB Receptacle	15		
User-Defined LEDs	14		
S			
Starter Kit Board			
Block Diagram	19		
Starter Kit Layout			
Bottom Assembly	15, 21		
Top Assembly	14, 20		
Starter Kit Schematics			
Sheet 1 of 3	22, 24		
Sheet 2 of 3	23, 25		
Sheet 3 of 3	25, 26		

PIC32 USB Starter Kit III User's Guide

NOTES:

NOTES:



MICROCHIP

Worldwide Sales and Service

AMERICAS

Corporate Office
2355 West Chandler Blvd.
Chandler, AZ 85224-6199
Tel: 480-792-7200
Fax: 480-792-7277
Technical Support:
<http://www.microchip.com/support>
Web Address:
www.microchip.com

Atlanta
Duluth, GA
Tel: 678-957-9614
Fax: 678-957-1455

Boston
Westborough, MA
Tel: 774-760-0087
Fax: 774-760-0088

Chicago
Itasca, IL
Tel: 630-285-0071
Fax: 630-285-0075

Cleveland
Independence, OH
Tel: 216-447-0464
Fax: 216-447-0643

Dallas
Addison, TX
Tel: 972-818-7423
Fax: 972-818-2924

Detroit
Farmington Hills, MI
Tel: 248-538-2250
Fax: 248-538-2260

Indianapolis
Noblesville, IN
Tel: 317-773-8323
Fax: 317-773-5453

Los Angeles
Mission Viejo, CA
Tel: 949-462-9523
Fax: 949-462-9608

Santa Clara
Santa Clara, CA
Tel: 408-961-6444
Fax: 408-961-6445

Toronto
Mississauga, Ontario,
Canada
Tel: 905-673-0699
Fax: 905-673-6509

ASIA/PACIFIC

Asia Pacific Office
Suites 3707-14, 37th Floor
Tower 6, The Gateway
Harbour City, Kowloon
Hong Kong
Tel: 852-2401-1200
Fax: 852-2401-3431

Australia - Sydney
Tel: 61-2-9868-6733
Fax: 61-2-9868-6755

China - Beijing
Tel: 86-10-8569-7000
Fax: 86-10-8528-2104

China - Chengdu
Tel: 86-28-8665-5511
Fax: 86-28-8665-7889

China - Chongqing
Tel: 86-23-8980-9588
Fax: 86-23-8980-9500

China - Hangzhou
Tel: 86-571-2819-3187
Fax: 86-571-2819-3189

China - Hong Kong SAR
Tel: 852-2943-5100
Fax: 852-2401-3431

China - Nanjing
Tel: 86-25-8473-2460
Fax: 86-25-8473-2470

China - Qingdao
Tel: 86-532-8502-7355
Fax: 86-532-8502-7205

China - Shanghai
Tel: 86-21-5407-5533
Fax: 86-21-5407-5066

China - Shenyang
Tel: 86-24-2334-2829
Fax: 86-24-2334-2393

China - Shenzhen
Tel: 86-755-8864-2200
Fax: 86-755-8203-1760

China - Wuhan
Tel: 86-27-5980-5300
Fax: 86-27-5980-5118

China - Xian
Tel: 86-29-8833-7252
Fax: 86-29-8833-7256

China - Xiamen
Tel: 86-592-2388138
Fax: 86-592-2388130

China - Zhuhai
Tel: 86-756-3210040
Fax: 86-756-3210049

ASIA/PACIFIC

India - Bangalore
Tel: 91-80-3090-4444
Fax: 91-80-3090-4123

India - New Delhi
Tel: 91-11-4160-8631
Fax: 91-11-4160-8632

India - Pune
Tel: 91-20-3019-1500

Japan - Osaka
Tel: 81-6-6152-7160
Fax: 81-6-6152-9310

Japan - Tokyo
Tel: 81-3-6880-3770
Fax: 81-3-6880-3771

Korea - Daegu
Tel: 82-53-744-4301
Fax: 82-53-744-4302

Korea - Seoul
Tel: 82-2-554-7200
Fax: 82-2-558-5932 or
82-2-558-5934

Malaysia - Kuala Lumpur
Tel: 60-3-6201-9857
Fax: 60-3-6201-9859

Malaysia - Penang
Tel: 60-4-227-8870
Fax: 60-4-227-4068

Philippines - Manila
Tel: 63-2-634-9065
Fax: 63-2-634-9069

Singapore
Tel: 65-6334-8870
Fax: 65-6334-8850

Taiwan - Hsin Chu
Tel: 886-3-5778-366
Fax: 886-3-5770-955

Taiwan - Kaohsiung
Tel: 886-7-213-7828
Fax: 886-7-330-9305

Taiwan - Taipei
Tel: 886-2-2508-8600
Fax: 886-2-2508-0102

Thailand - Bangkok
Tel: 66-2-694-1351
Fax: 66-2-694-1350

EUROPE

Austria - Wels
Tel: 43-7242-2244-39
Fax: 43-7242-2244-393

Denmark - Copenhagen
Tel: 45-4450-2828
Fax: 45-4485-2829

France - Paris
Tel: 33-1-69-53-63-20
Fax: 33-1-69-30-90-79

Germany - Munich
Tel: 49-89-627-144-0
Fax: 49-89-627-144-44

Italy - Milan
Tel: 39-0331-742611
Fax: 39-0331-466781

Netherlands - Druenen
Tel: 31-416-690399
Fax: 31-416-690340

Spain - Madrid
Tel: 34-91-708-08-90
Fax: 34-91-708-08-91

UK - Wokingham
Tel: 44-118-921-5869
Fax: 44-118-921-5820

08/20/13