

TR-58D-RJ

Transceiver Module

Data Sheet



Description

TR-58D-RJ is a family of IQRF transceiver modules operating in the 868 MHz and 916 MHz license free ISM (Industry, Scientific and Medical) frequency band. Its highly integrated ready-to-use design requires no external components. Microcontroller with built-in operating system, excellent development support, integrated LDO regulator, serial EEPROM and temperature sensor dramatically reduce time of application development. Ultra low power consumption predetermines these modules for use in battery powered applications.



Key features

- Complete solution with operating system, easy to use
- FSK modulation
- Selectable RF band 868 / 916 MHz, multiple channel
- MCU with extended resources, user interrupt capability
- Extra low power consumption, power management modes
- SPI interface supported by OS on background
- Serial EEPROM and temperature sensor
- Programmable HW timer
- A/D converter (1 channel)
- PWM output
- Battery monitoring
- 2 LEDs
- RJ-45 connector, 8 pins, 4 I/Os
- Protective diodes on I/O pins
- Fully coated
- Resistive against UV radiation

Applications

- Outdoor lighting
- Telemetry
- Building automation
- Wireless control & regulation
- Access control
- Remote data acquisition
- Communication links
- RF connectivity in many other areas

Block diagram

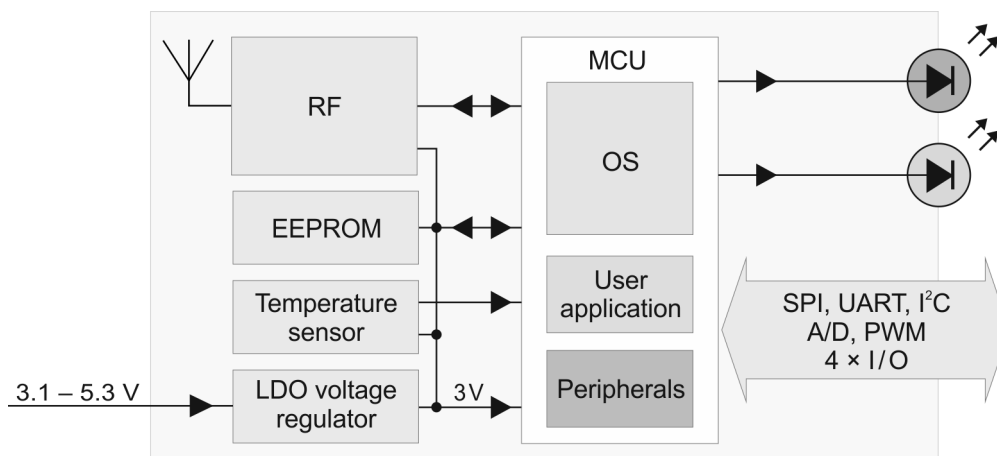

Information contained in this publication regarding device applications and the like is provided only for your convenience and may be superseded by updates. It is your responsibility to ensure that your application meets with your specifications.

MICRORISC MAKES NO REPRESENTATIONS OR WARRANTIES OF ANY KIND TO STATED CONDITION, QUALITY, PERFORMANCE, MERCHANTABILITY OR FITNESS FOR PURPOSE and disclaims all liability arising from this information and its use. Use of MICRORISC devices in life support and/or safety applications is entirely at the buyer's risk, and the buyer agrees to defend, indemnify and hold harmless MICRORISC from any and all damages, claims, suits, or expenses resulting from such use. No licenses are conveyed, implicitly or otherwise, under any MICRORISC intellectual property rights.

Electrical specifications

Typical values unless otherwise stated

Parameters specified in this datasheet are typical values. They are at power supply $V_{OUT} = 3\text{ V}$ only. V_{OUT} voltage different from 3 V can impact on RF range and other parameters.

Supply voltage (V_{CC})	3.1 V to 5.3 V
LDO output (V_{OUT})	+3 V \pm 60 mV ($V_{CC} > 3.1\text{ V}$), 100 mA max.
Operating temperature ¹	-40 °C to +85 °C
Supply current	
Sleep mode	1.9 μ A (if all peripherals including MRF49XA disabled ³)
Run mode	1 mA (MRF49XA disabled)
Additional LED supply current	cca 2 mA (if one or two LEDs on). Rough value for brief guidance only.
RX mode	STD mode: 13 mA LP mode ⁴ : OS v3.01D: 400 μ A, from OS v3.02D: 330 μ A XLP mode ⁴ : OS v3.01D: 35 μ A, from OS v3.02D: 25 μ A
TX mode	14 mA – 24 mA (according to RF output power)
RF Band	868 MHz or 916 MHz (software selectable)
Channels	See IQRF OS User's guide, Appendix 2, Channel maps
RF data modulation	FSK (frequency-shift keying)
RF data transmission bit rate	1.2 kb/s ⁵ , 19.2 kb/s, 57.6 kb/s ⁵ , 86.2 kb/s ⁵
RFIC RF sensitivity	See MRF49XA datasheet
RFIC RF output power	Programmable in 8 levels (0 – 7), -2.5 dBm/level, see MRF49XA datasheet
RF range ²	Up to 300 m @ 19.2 kb/s
Input voltage on pins 1, 3, 4, 5, 6	0 V to V_{OUT}
Input voltage on pin 2	0 V to 3 V
A/D converter	10 bit, 1 input, see PIC16LF1938 datasheet
Temperature sensor	MCP9804
Size (L x W x H)	29 mm x 40 mm x 52 mm

Note 1: RF range may change with lower temperature. Frost, condensation or humidity over 85% may disable module functionality. Module suitability should be tested in final application before volume use.

Note 2: RF range strongly depends on module orientation, surroundings and other conditions.

Note 3: Additional current is consumed when a peripheral (e.g. watchdog, Brown-out detection etc.) is enabled.

Note 4: Depends on interferences.

Note 5: RF bit rates different from 19.2 kb/s are preliminary, for experimental purpose only.

Users have to ensure observing local provisions and restrictions relating to the use of short range devices by software, e.g. the CEPT ERC/REC 70-03 Recommendation and subsequent amendments in EU.

TR modules with metallic shielding of RF circuitry (with the "F" postfix, e.g. TR-58DF-RJ) must be used in countries where FCC provision is valid.

Caution: Electrostatic sensitive device. Observe appropriate precautions for handling

Absolute maximum ratings

Stresses above listed maximum values may cause permanent damage to the device and affect device reliability. Functional operation at these or any other conditions beyond those specified is not supported.

Supply voltage (V_{CC})	5.5 V
Voltage on C1, C2, C5 to C8 pins vs. GND	-0.3 V to ($V_{OUT} + 0.3$ V)
Storage temperature	-40 °C to +85 °C
Ambient temperature under bias	-40 °C to +85 °C

Simplified schematic

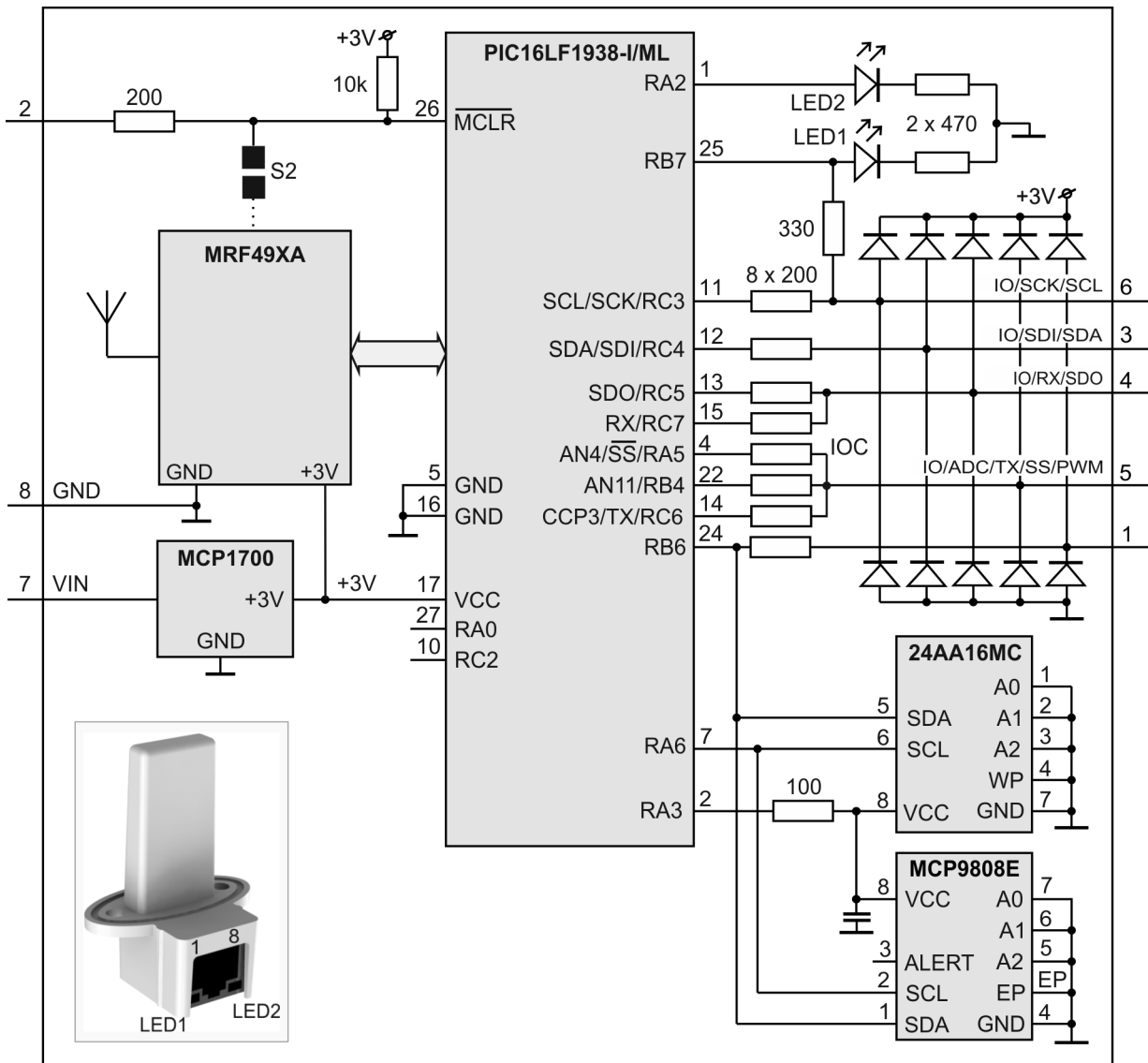

Basic components

IC	Type	Manufacturer
MCU	PIC16LF1938-I/ML	Microchip
RF IC	MRF49XA	Microchip
LDO voltage regulator	MCP1700	Microchip
Temperature sensor	MCP9804	Microchip
EEPROM	24AA16/MC	Microchip

For more information refer to datasheets of ICs used.

Pin	Name	Description
1		For TR manufacturer only. Leave unconnected.
2		For TR manufacturer only. Leave unconnected.
3	IO/SDI/SDA	
	RC4	General I/O pin
	SDI	SPI data
	SDA	I ² C data
4	IO/RX/SDO⁶	
	RC5	General I/O pin
	SDO	SPI data out
	RC7	General I/O pin
	RX	UART RX
5	IO/ADC/TX/-SS /PWM	
	RA5	General I/O pin,
	-SS	SPI Slave select
	AN4	Analog A/D input
	RC6	General I/O pin
	TX	UART TX
	CCP3	PWM output
	RB4	General I/O pin, programmable pull-up and interrupt/wake-up on change (IOC)
	AN11	Analog A/D input
6	IO/SCK/SCL	
	RC3	General I/O pin (multiplexed also with LED1 via a resistor)
	SCK	SPI clock input
	SCL	I ² C clock
7	VIN	Power supply voltage
8	GND	Ground



Note 6: This pin is used as output during initial ~250 ms boot-up to recognize programming mode.

I/O interface

Standard 8-pin RJ-45 connector is used.

LED interface

LED1 It can also be controlled via IQRF OS functions dedicated to LEDR. LED1 control pin is multiplexed with pin 6 via a resistor.

LED2 It can also be controlled via IQRF OS functions dedicated to LEDG.

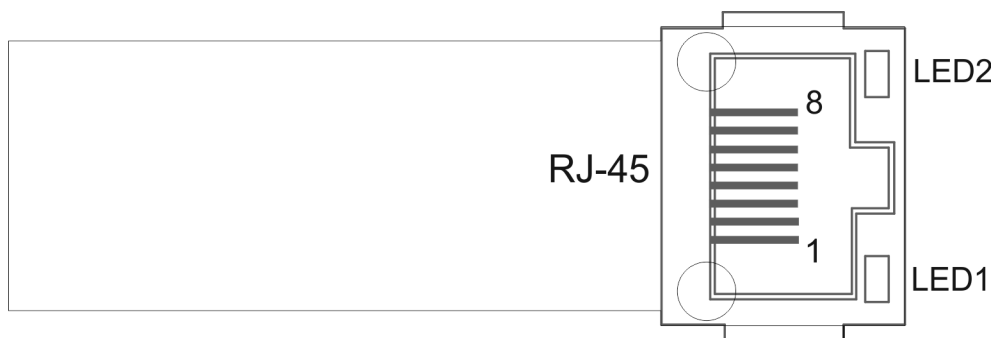

Figure 1: Relative RF range vs. level for the `setTxpower(level)` function. Refer to IQRF OS Reference guide.

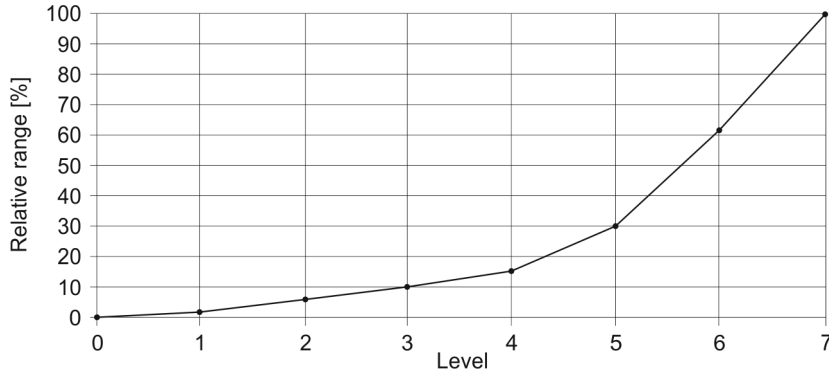

Figure 2: Relative RF range vs. level for the `checkRF(level)` function. Refer to IQRF OS Reference guide.

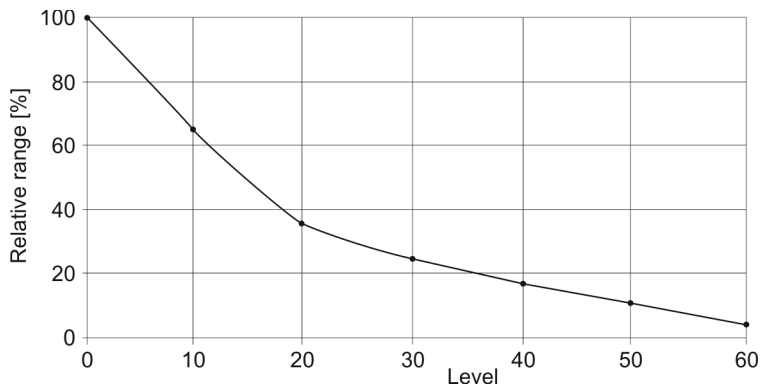
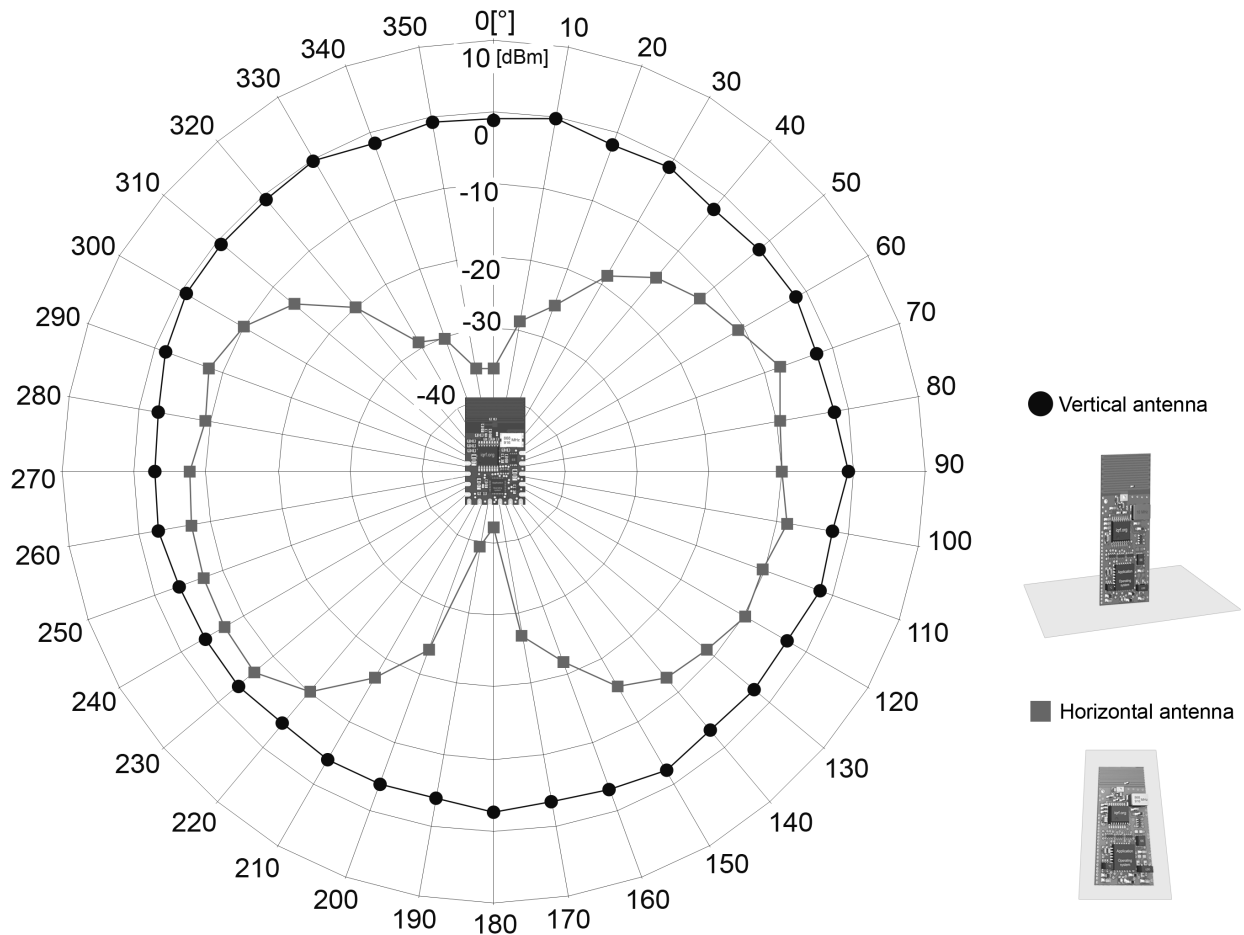

Figure 3: Relative RF range vs. antenna orientation (radiation patterns)



Relative decrease of RF input signal vs. antenna edge spacing to conductive areas

Conductive areas close to the antenna must be avoided.

Figure 4: Parallel arrangement

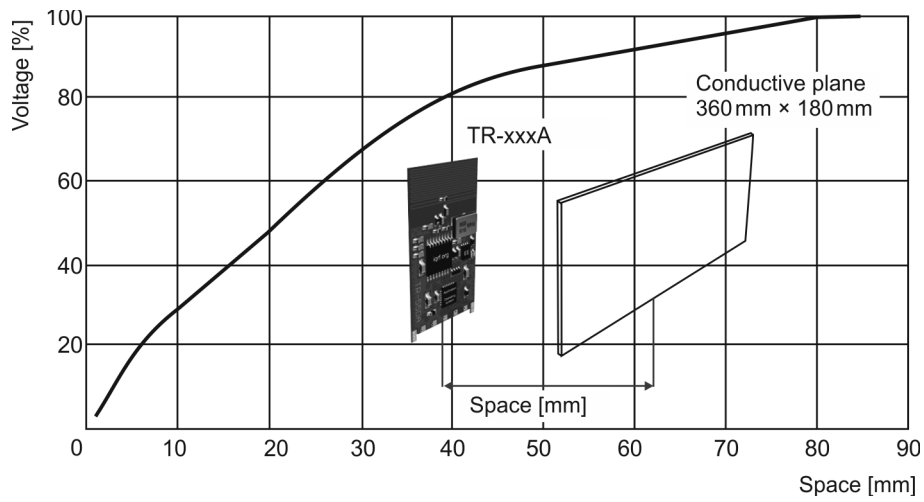

Application

Mechanical drawings

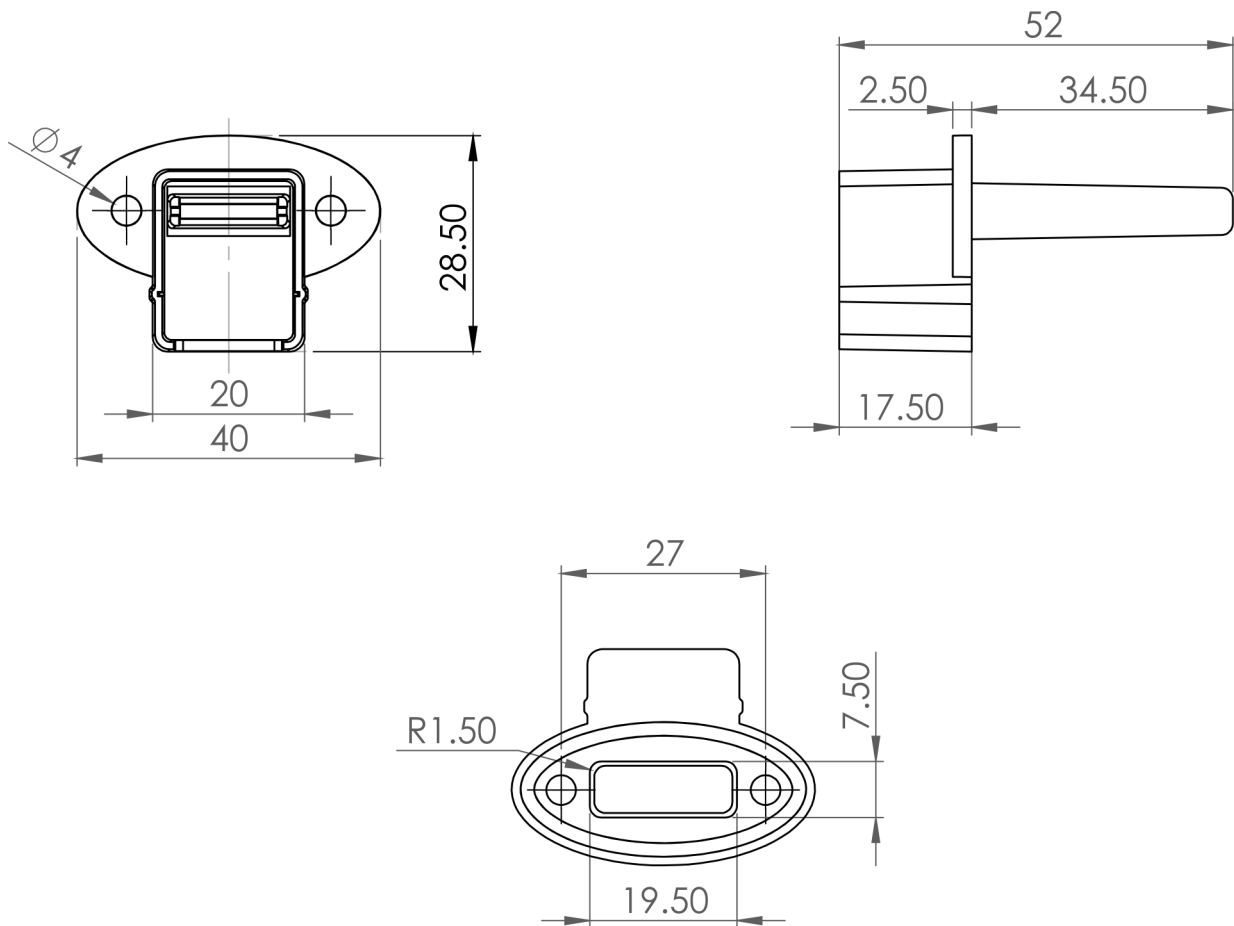

Assembly

TR-58Dx-RJ modules should be mounted with the O-ring \varnothing 25 mm x 1.5 mm (d1 x d2) by two screws.

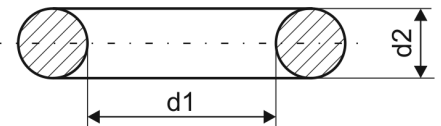

Operating system

See IQRF OS User's guide and IQRF OS Reference guide.

Software

See Application examples on www.iqrf.org website.

Programming

There are two possibilities to upload an application program in TR-58Dx-RJ modules:

- Wireless upload (RFPGM – RF programming™). See the IQRF OS User's guide, chapter RF programming, IQRF IDE Help and E12-RFPGM-TST example.
- Wired upload using the CK-USB-04(A) programmer and interconnection kit KON-RJ-01. Refer to the CK-USB-04(A) and KON-RJ-01 User's guides for details regarding the upload.

Product information

Pack list

- TR-84DA(F)-RJ Transceiver module, coated, O-ring included.

Ordering codes

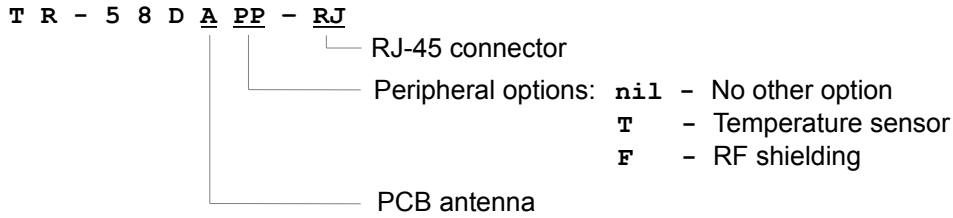

Type	Antenna	Temperature sensor	RF shielding
TR-58DAT-RJ	On-board PCB	Yes	-
TR-58DATF-RJ	On-board PCB	Yes	Yes

Recommended options

- CK-USB-04(A) Programmer and debugger for IQRF TR modules
- KON-RJ-01 Kit to connect TR-58D-RJ with CK-USB-04(A)

Document history

- 140120 Datasheet file renamed from DS_TR-58D-RJ_131114 to Datasheet_TR-58D-RJ_140120.
- 131114 Certification updated for the latest directives.
- 131108 First release

Sales and Service

Corporate office

MICRORISC s.r.o., Prumyslova 1275, 506 01 Jicin, Czech Republic, EU
Tel: +420 493 538 125, Fax: +420 493 538 126, www.microrisc.com

Partners and distribution

Please visit www.iqrf.org/partners

Quality management

ISO 9001 : 2009 certified

Complies with ETSI directives EN 301489-1 V1.9.2:2011, EN 301489-3 V1.6.1:2013, EN 300220-1 V2.4.1:2012, EN 300220-2 V2.4.1:2012 and VO-R/10/04.2012-7.

Complies with FCC directives FCC CFR, Title 47, Part 15, Section 15.209, FCC CFR, Title 47, Part 15, Section 15.249

Complies with Directive 2002/95/EC (RoHS)



Trademarks

The IQRF name and logo and MICRORISC name are registered trademarks of MICRORISC s.r.o. PIC, SPI, Microchip and all other trademarks mentioned herein are property of their respective owners.

Legal

All information contained in this publication is intended through suggestion only and may be superseded by updates without prior notice. No representation or warranty is given and no liability is assumed by MICRORISC s.r.o. with respect to the accuracy or use of such information.

Without written permission it is not allowed to copy or reproduce this information, even partially.

No licenses are conveyed, implicitly or otherwise, under any intellectual property rights.

The IQRF® products utilize several patents (CZ, EU, US)

On-line support: support@iqrf.org



Smarter wireless. Simply.