

M54646AP

2-PHASE STEPPER MOTOR DRIVER

DESCRIPTION

The M54646AP is a semiconductor IC to drive bipolar stepper motors by controlling winding current with reference to a designated current level.

FEATURES

- Wide driver voltage range (10 – 40V)
- Wide output current control range (20 – 800mA)
- Bipolar and constant current control
- Built-in flywheel diode
- Built-in thermal protection circuit

APPLICATION

Office automation equipment such as printers, FDDs, HDDs and facsimiles

FUNCTION

M54646AP Integrated Circuit drives two-phase bipolar stepper motors while controlling winding current: It controls winding current direction by inputting phases (pins 14 and 15) and, at the same time, controls winding current amperage with terminals VR (pins ② and ②⑦).

Provided with control circuits that output two phases, this IC is sufficient to drive a two-phase bipolar stepper motor.

PIN CONFIGURATION (TOP VIEW)

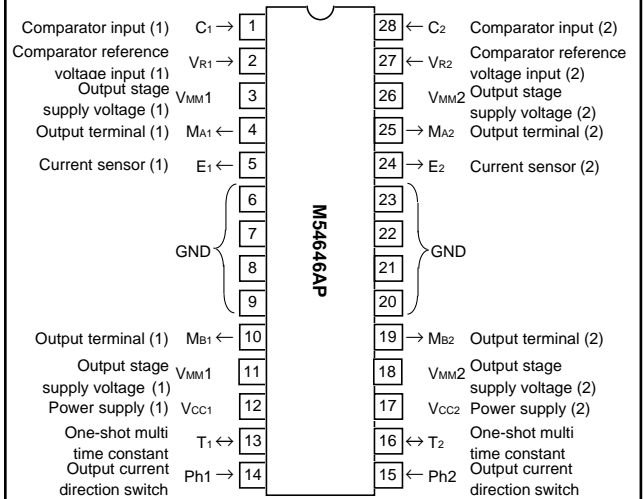

Outline 28P4B

BLOCK DIAGRAM

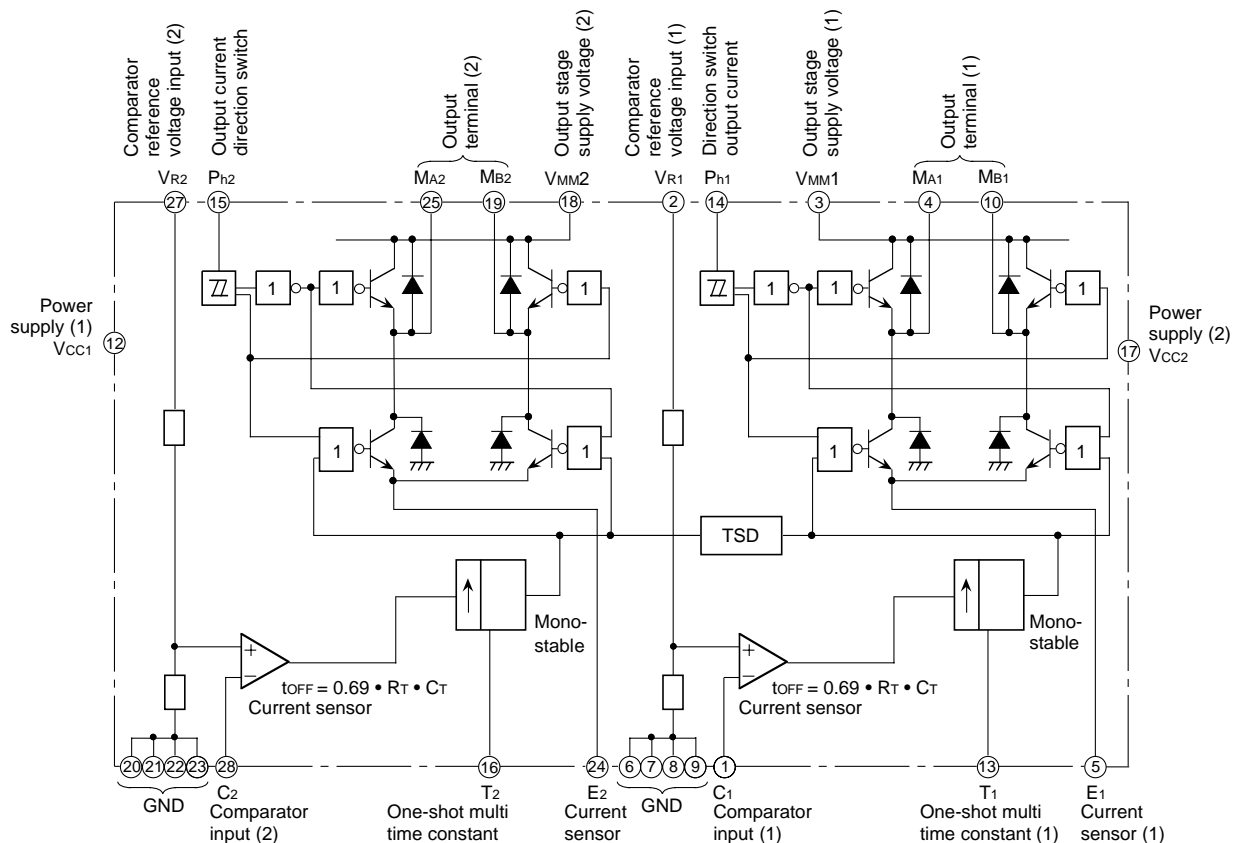

ABSOLUTE MAXIMUM RATINGS (Ta = 25°C unless otherwise noted)

Symbol	Parameter	Conditions	Ratings	Unit
Vcc	Supply voltage		-0.3 – 7	V
VMM	Output stage supply voltage		-0.3 – 45	V
VL	Logic input voltage		-0.3 – 6	V
Vc	Analog input voltage		-0.3 – Vcc	V
VR	Reference input voltage		-0.3 – 15	V
IL	Logic input current		-10	mA
Ic	Analog input current		-10	mA
Io	Output current		±1000	mA
Pd	Power dissipation	Measured with IC mounted on board	1.92	W
Topr	Operating temperature		-20 – 85	°C
Tstg	Storage temperature		-55 – 125	°C

RECOMMENDED OPERATIONAL CONDITIONS (Ta = 25°C unless otherwise noted)

Symbol	Parameter	Limits			Unit
		Min.	Typ.	Max.	
Vcc	Supply voltage	4.5	5	5.5	V
VMM	Output stage supply voltage	10		40	V
Io	Output current	20		800	mA
tPLH	Logic input rise time			2	μs
tPHL	Logic input fall time			2	μs
TON	Thermal shutdown temperature		165		°C

ELECTRICAL CHARACTERISTICS (Vcc = 5V, Ta = 25°C unless otherwise noted)

Symbol	Parameter		Test Conditions	Limits			Unit
				Min.	Typ.	Max.	
V _{IH}	Logic input voltage	"H"	Vcc = 5V	2.0		Vcc	V
V _{IL}		"L"		0		0.8	V
I _{CH}	Comparator threshold voltage		VR = 5V	400	430	450	mA
I _{CO}	Comparator input current			-20		20	μA
I _{OFF}	Output cutoff current					100	μA
V _{sat}	Total saturation voltage		Sensing resistance is not included. (Io = 500mA)			3.5	V
t _{OFF}	Cutoff time		VMM = 10V, tON ≥ 5μs	25	30	35	μs
t _d	Turn-off delay		dVK/dt ≥ 50mV/μs		1.6	2.0	μs
I _{CC}	Power current		Vcc = 5V, 1 phase			25	mA
I _{IH}	Logic input current	"H"	VI = 2.4V			20	μA
I _{IL}		"L"	VI = 0.4V	-0.4			mA

SWITCHING CHARACTERISTICS

SWITCHING WAVEFORM

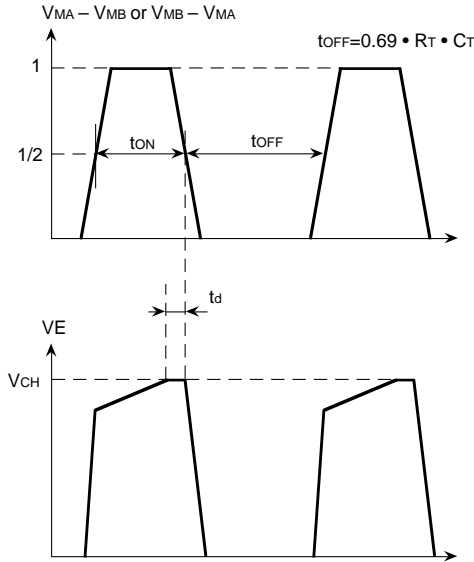

TIMING CHART

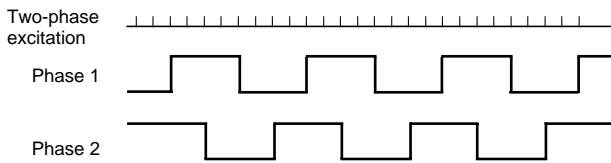

APPLICATION DIRECTIONS

- (1) Phase input
Phase input determines output mode:

PHASE	MA	MB
H	H	L
L	L	H

- (2) V_R (reference voltage)
Stepless current level variation is available by continuously changing V_R .
- (3) Current sensor
Compares voltage converted from amperage by current sensing resistor to designated reference voltage level. When they are the same, comparator triggers Mono-stable, and shuts off output transistor during time frame t_{OFF} . During this period, current level decreases to slightly below reference level. When period has passed, output transistor is reactivated. This series of operations is repeated.
- (4) Single-pulse generator
Mono-stable is triggered at comparator output phase rise edge. Mono-stable output pulse width is determined by input to timing terminals R_T and C_T , as follows:
 $t_{OFF} = 0.69 \times R_T \times C_T$
If new trigger occurs during t_{OFF} , it is ignored.
- (5) Analog control
Stepless output current level variation is available by continuously changing voltage V_R or feedback voltage to comparator.

AREA OF SAFE OPERATION

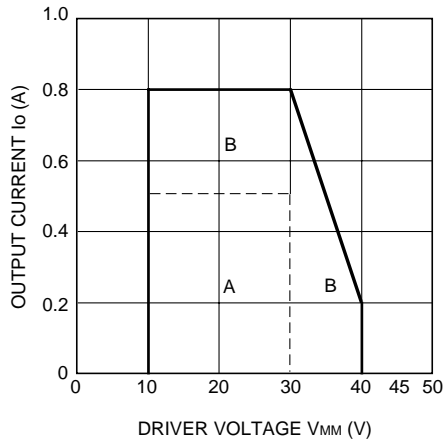

A: Recommended operational range
 B: External Schottky diode to be connected between output terminal and power terminal as well as between output terminal and GND.

* This regulation is for temporary electric power use. For continuous use, be sure power dissipation does not go beyond package's operational range.

THERMAL DERATING

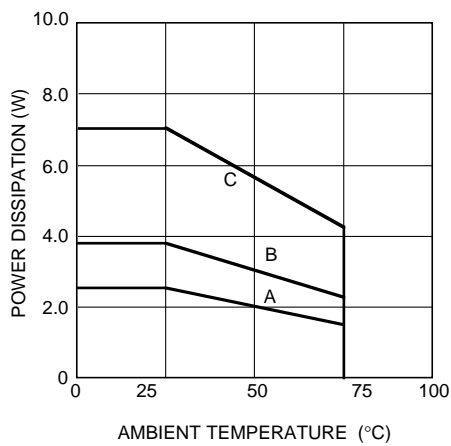

$\theta_{j-c} = 8^{\circ}\text{C/W}$

A: Mounted on 25cm² glassfiber epoxy resin circuit board with one side copper-foiled

$\theta_{c-a} = 42^{\circ}\text{C/W}$

B: With aluminum heat sink (1t) 10cm²

$\theta_{c-a} = 25^{\circ}\text{C/W}$

C: With aluminum heat sink (1t) 100cm²

$\theta_{c-a} = 10^{\circ}\text{C/W}$

$T_{j(max)} = 150^{\circ}\text{C}$

APPLICATION EXAMPLE

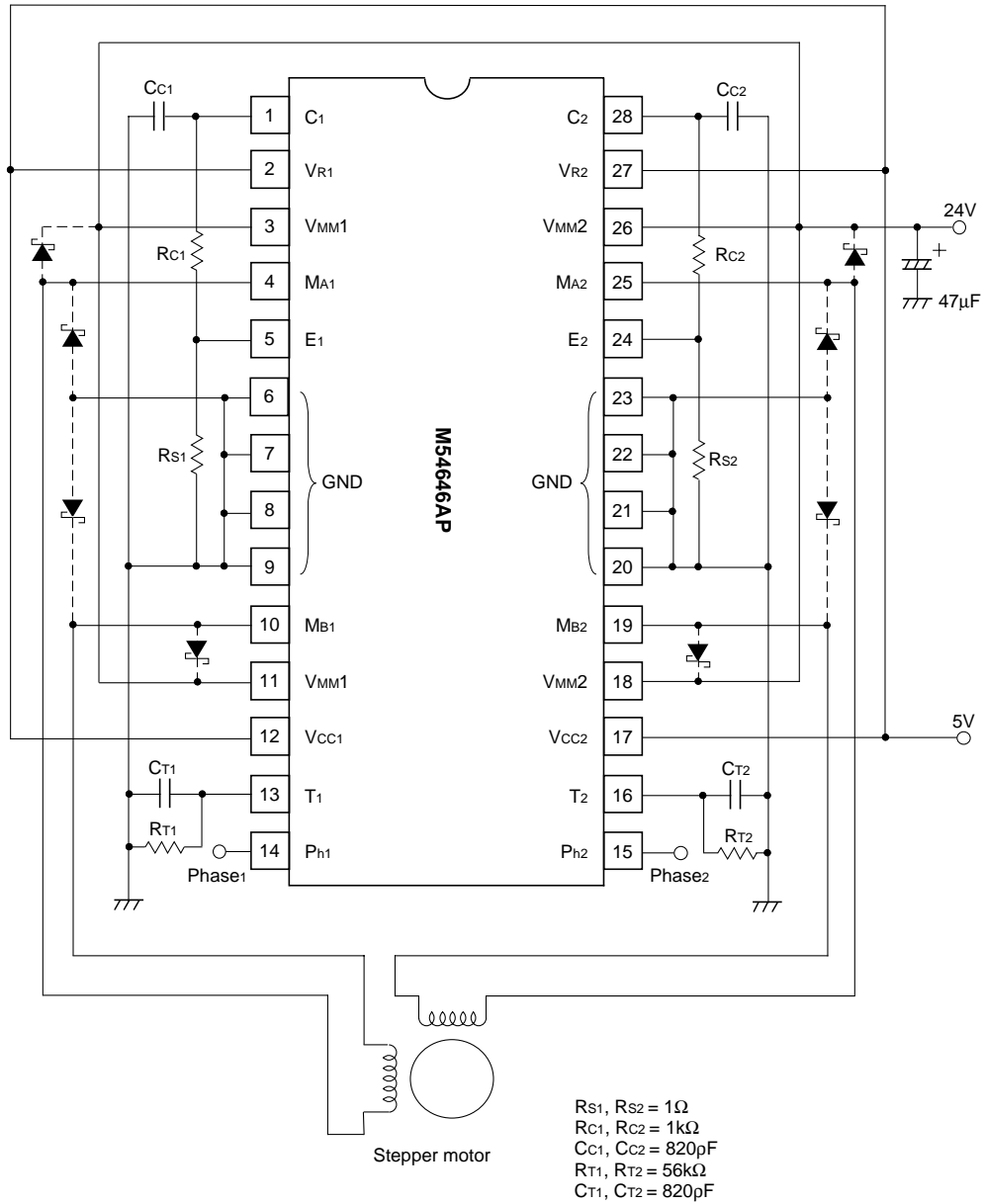

CAUTION

- (1) Be sure to short-circuit Vcc1 and Vcc2 before use.
 - (2) When IC total output current changes greatly, e.g. when output current flows intermittently due to thermal protection operation, supply voltage may fluctuate. Provide power supply and wiring such that even in such a case amperage will not exceed absolute maximum rating.
 - (3) Excessive power voltage fluctuations may cause unstable IC operation. To regulate such fluctuations, connect capacitor between terminals Vcc and GND as close to IC terminal as possible. (Refer to application example.)
 - (4) Thermal protection function
 - Thermal protection characteristics may differ depending on wiring layout. Be sure to test IC on circuit board before use. After circuit board is replaced, test IC again.
 - Circuit boards on which this IC mounted are designed such that impedance between power supply and output terminal will be kept low; therefore, IC output terminal may be short-circuited internally if excessive surge voltage is applied accidentally from outside. To prevent circuit board from burning in such a case, take safety measures such as installation of a fuse.
 - (5) Flywheel diode

This IC has built in flywheel diode to provide a return current route to motor. To prevent overheating and malfunction in operational areas where great current and voltage are applied, install a Schottky diode externally. For details, refer to "Area of Safe Operation" and "Application Example."
-