

## Features

- Very high speed: 45 ns
  - Wide voltage range: 2.20 V to 3.60 V
- Temperature range:
  - Industrial: -40 °C to +85 °C
  - Automotive-A: -40 °C to +85 °C
- Pin compatible with CY62148DV30
- Ultra low standby power
  - Typical standby current: 1 μA
  - Maximum standby current: 7 μA (Industrial)
- Ultra low active power
  - Typical active current: 2 mA at f = 1 MHz
- Easy memory expansion with  $\overline{CE}$  and  $\overline{OE}$  features
- Automatic power down when deselected
- Complementary metal oxide semiconductor (CMOS) for optimum speed and power
- Available in Pb-free 36-ball very fine-pitch ball grid array (VFPGA), 32-pin thin small outline package (TSOP) II, and 32-pin small outline integrated circuit (SOIC) [1] packages

## Functional Description

The CY62148EV30 is a high performance CMOS static RAM organized as 512 K words by 8 bits. This device features advanced circuit design to provide ultra low active current. This is ideal for providing More Battery Life™ (MoBL<sup>®</sup>) in portable applications such as cellular telephones. The device also has an automatic power down feature that significantly reduces power consumption. Placing the device into standby mode reduces power consumption by more than 99 percent when deselected ( $\overline{CE}$  HIGH). The eight input and output pins (I/O<sub>0</sub> through I/O<sub>7</sub>) are placed in a high impedance state when the device is deselected ( $\overline{CE}$  HIGH), the outputs are disabled ( $\overline{OE}$  HIGH), or during a write operation ( $\overline{CE}$  LOW and  $\overline{WE}$  LOW).

To write to the device, take Chip Enable ( $\overline{CE}$ ) and Write Enable ( $\overline{WE}$ ) inputs LOW. Data on the eight I/O pins (I/O<sub>0</sub> through I/O<sub>7</sub>) is then written into the location specified on the address pins (A<sub>0</sub> through A<sub>18</sub>).

To read from the device, take Chip Enable ( $\overline{CE}$ ) and Output Enable ( $\overline{OE}$ ) LOW while forcing Write Enable ( $\overline{WE}$ ) HIGH. Under these conditions, the contents of the memory location specified by the address pins appear on the I/O pins.

## Logic Block Diagram

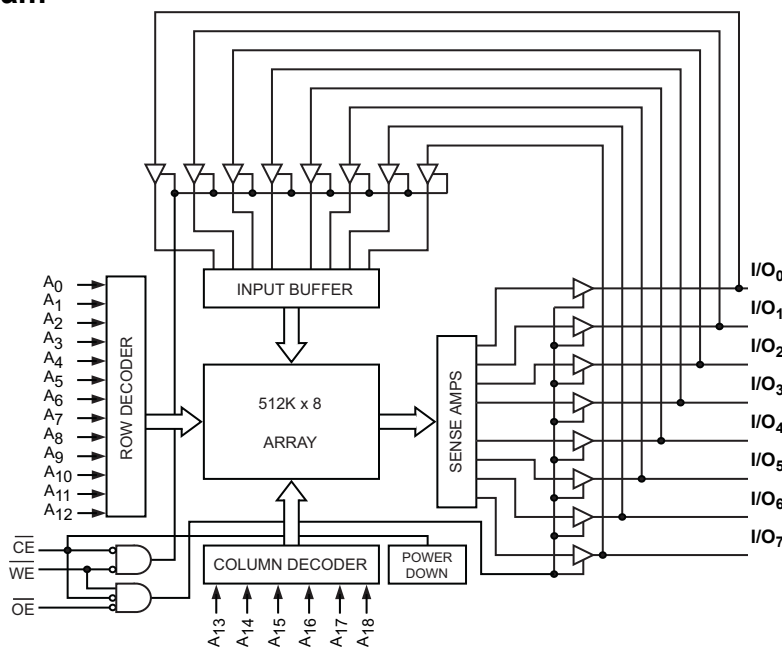

### Note

1. SOIC package is available only in 55 ns speed bin.

**Contents**

<b>Pin Configuration</b> .....	<b>3</b>	<b>Ordering Information</b> .....	<b>11</b>
<b>Product Portfolio</b> .....	<b>3</b>	Ordering Code Definitions .....	11
<b>Maximum Ratings</b> .....	<b>4</b>	<b>Package Diagrams</b> .....	<b>12</b>
<b>Operating Range</b> .....	<b>4</b>	<b>Acronyms</b> .....	<b>15</b>
<b>Electrical Characteristics</b> .....	<b>4</b>	<b>Document Conventions</b> .....	<b>15</b>
<b>Capacitance</b> .....	<b>5</b>	Units of Measure .....	15
<b>Thermal Resistance</b> .....	<b>5</b>	<b>Document History Page</b> .....	<b>16</b>
<b>AC Test Loads and Waveforms</b> .....	<b>5</b>	<b>Sales, Solutions, and Legal Information</b> .....	<b>19</b>
<b>Data Retention Characteristics</b> .....	<b>6</b>	Worldwide Sales and Design Support .....	19
<b>Data Retention Waveform</b> .....	<b>6</b>	Products .....	19
<b>Switching Characteristics</b> .....	<b>7</b>	PSoC® Solutions .....	19
<b>Switching Waveforms</b> .....	<b>8</b>	Cypress Developer Community .....	19
<b>Truth Table</b> .....	<b>10</b>	Technical Support .....	19

## Pin Configuration

VFBGA, SOIC and TSOP II pinouts are as follows. [2, 3]

**36-ball VFBGA pinout  
Top View**

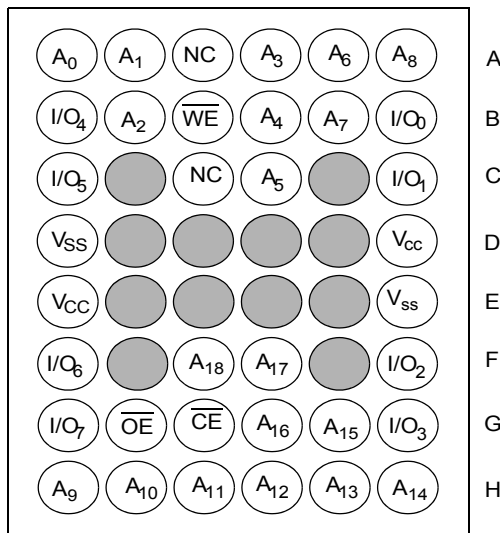

**32-pin SOIC/TSOP II pinout  
Top View**

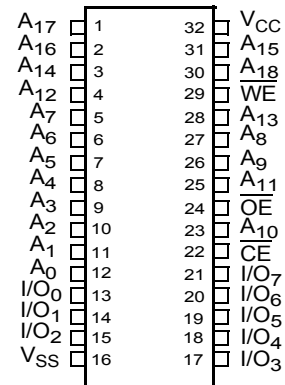

## Product Portfolio

Product	Range	V <sub>CC</sub> Range (V)			Speed (ns)	Power Dissipation						
						Operating I <sub>CC</sub> (mA)				Standby I <sub>SB2</sub> (μA)		
		Min	Typ <sup>[4]</sup>	Max		f = 1 MHz		f = f <sub>max</sub>				
Typ <sup>[4]</sup>	Max	Typ <sup>[4]</sup>	Max	Typ <sup>[4]</sup>	Max	Typ <sup>[4]</sup>	Max					
CY62148EV30LL	VFBGA	Industrial	2.2	3.0	3.6	45	2	2.5	15	20	1	7
	TSOP II	Industrial / Automotive-A										
	SOIC	Industrial	2.2	3.0	3.6	55	2	2.5	15	20	1	7

### Notes

- SOIC package is available only in 55 ns speed bin.
- NC pins are not connected on the die.
- Typical values are included for reference only and are not guaranteed or tested. Typical values are measured at V<sub>CC</sub> = V<sub>CC(typ)</sub>, T<sub>A</sub> = 25 °C.

## Maximum Ratings

Exceeding maximum ratings may impair the useful life of the device. These user guidelines are not tested.

Storage temperature .....	-65 °C to +150 °C
Ambient temperature with power applied .....	55 °C to +125 °C
Supply voltage to ground potential .....	-0.3 V to $V_{CC(max)}$ + 0.3 V
DC voltage applied to outputs in High Z State <sup>[5, 6]</sup> .....	-0.3 V to $V_{CC(max)}$ + 0.3 V

DC input voltage <sup>[5, 6]</sup> .....	-0.3 V to $V_{CC(max)}$ + 0.3 V
Output current into outputs (LOW) .....	20 mA
Static discharge voltage (MIL-STD-883, Method 3015) .....	> 2001 V
Latch up current .....	> 200 mA

## Operating Range

Product	Range	Ambient Temperature	$V_{CC}$ <sup>[7]</sup>
CY62148EV30	Industrial / Automotive-A	-40 °C to +85 °C	2.2 V to 3.6 V

## Electrical Characteristics

Over the Operating Range

Parameter	Description	Test Conditions	-45 (Industrial / Automotive-A)			-55 <sup>[8]</sup>			Unit	
			Min	Typ <sup>[9]</sup>	Max	Min	Typ <sup>[9]</sup>	Max		
V <sub>OH</sub>	Output high voltage	I <sub>OH</sub> = -0.1 mA	2.0	-	-	2.0	-	-	V	
		I <sub>OH</sub> = -1.0 mA, V <sub>CC</sub> ≥ 2.70 V	2.4	-	-	2.4	-	-	V	
V <sub>OL</sub>	Output low voltage	I <sub>OL</sub> = 0.1 mA	-	-	0.4	-	-	0.2	V	
		I <sub>OL</sub> = 2.1 mA, V <sub>CC</sub> ≥ 2.70 V	-	-	0.4	-	-	0.4	V	
V <sub>IH</sub>	Input high voltage	V <sub>CC</sub> = 2.2 V to 2.7 V	1.8	-	V <sub>CC</sub> + 0.3 V	1.8	-	V <sub>CC</sub> + 0.3 V	V	
		V <sub>CC</sub> = 2.7 V to 3.6 V	2.2	-	V <sub>CC</sub> + 0.3 V	2.2	-	V <sub>CC</sub> + 0.3 V	V	
V <sub>IL</sub>	Input low voltage	V <sub>CC</sub> = 2.2 V to 2.7 V	For VFPGA and TSOP II packages	-0.3	-	0.6	-	-	-	V
			For SOIC package	-	-	-	-0.3	-	0.4 <sup>[10]</sup>	V
		V <sub>CC</sub> = 2.7 V to 3.6 V	For VFPGA and TSOP II packages	-0.3	-	0.8	-	-	-	V
			For SOIC package	-	-	-	-0.3	-	0.6 <sup>[10]</sup>	V
I <sub>IX</sub>	Input leakage current	GND ≤ V <sub>I</sub> ≤ V <sub>C</sub>	-1	-	+1	-1	-	+1	μA	
I <sub>OZ</sub>	Output leakage current	GND ≤ V <sub>O</sub> ≤ V <sub>CC</sub> , Output disabled	-1	-	+1	-1	-	+1	μA	
I <sub>CC</sub>	V <sub>CC</sub> operating supply current	f = f <sub>max</sub> = 1/t <sub>RC</sub>	V <sub>CC</sub> = V <sub>CC(max)</sub> , I <sub>OUT</sub> = 0 mA, CMOS levels	-	15	20	-	15	20	mA
		f = 1 MHz		-	2	2.5	-	2	2.5	
I <sub>SB1</sub> <sup>[11]</sup>	Automatic CE power down current – CMOS inputs	CE ≥ V <sub>CC</sub> - 0.2 V, V <sub>IN</sub> ≥ V <sub>CC</sub> - 0.2 V, V <sub>IN</sub> ≤ 0.2 V f = f <sub>max</sub> (Address and Data Only), f = 0 ( $\overline{OE}$ and $\overline{WE}$ ), V <sub>CC</sub> = 3.60 V	-	1	7	-	1	7	μA	
I <sub>SB2</sub> <sup>[11]</sup>	Automatic CE power down current – CMOS inputs	CE ≥ V <sub>CC</sub> - 0.2 V, V <sub>IN</sub> ≥ V <sub>CC</sub> - 0.2 V or V <sub>IN</sub> ≤ 0.2 V, f = 0, V <sub>CC</sub> = 3.60 V	-	1	7	-	1	7	μA	

### Notes

- V<sub>IL(min)</sub> = -2.0 V for pulse durations less than 20 ns.
- V<sub>IH(max)</sub> = V<sub>CC</sub> + 0.75 V for pulse durations less than 20 ns.
- Full device AC operation assumes a minimum of 100 μs ramp time from 0 to V<sub>CC(min)</sub> and 200 μs wait time after V<sub>CC</sub> stabilization.
- SOIC package is available only in 55 ns speed bin.
- Typical values are included for reference only and are not guaranteed or tested. Typical values are measured at V<sub>CC</sub> = V<sub>CC(typ)</sub>, T<sub>A</sub> = 25 °C.
- Under DC conditions the device meets a V<sub>IL</sub> of 0.8V (for V<sub>CC</sub> range of 2.7 V to 3.6 V) and 0.6 V (for V<sub>CC</sub> range of 2.2 V to 2.7 V). However, in dynamic conditions Input LOW voltage applied to the device must not be higher than 0.6V and 0.4V for the above ranges. This is applicable to SOIC package only.
- Chip Enable (CE) must be HIGH at CMOS level to meet the I<sub>SB1</sub> / I<sub>SB2</sub> / I<sub>CCDR</sub> spec. Other inputs can be left floating.

### Capacitance

Parameter <sup>[12]</sup>	Description	Test Conditions	Max	Unit
C <sub>IN</sub>	Input capacitance	T <sub>A</sub> = 25 °C, f = 1 MHz, V <sub>CC</sub> = V <sub>CC(typ)</sub>	10	pF
C <sub>OUT</sub>	Output capacitance		10	pF

### Thermal Resistance

Parameter <sup>[12]</sup>	Description	Test Conditions	36-ball VFB-GA Package	32-pin TSOP II Package	32-pin SOIC Package	Unit
Θ <sub>JA</sub>	Thermal resistance (junction to ambient)	Still air, soldered on a 3 × 4.5 inch, two-layer printed circuit board	72	75.13	55	°C/W
Θ <sub>JC</sub>	Thermal resistance (junction to case)		8.86	8.95	22	°C/W

### AC Test Loads and Waveforms

Figure 1. AC Test Loads and Waveforms

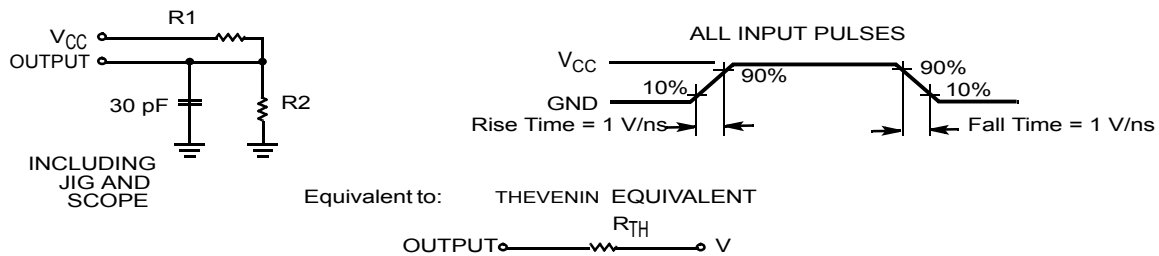

Parameters	2.50 V	3.0 V	Unit
R <sub>1</sub>	16667	1103	Ω
R <sub>2</sub>	15385	1554	Ω
R <sub>TH</sub>	8000	645	Ω
V <sub>TH</sub>	1.20	1.75	V

**Note**

12. Tested initially and after any design or process changes that may affect these parameters.

## Data Retention Characteristics

Over the Operating Range

Parameter	Description	Conditions	Min	Typ <sup>[13]</sup>	Max	Unit
$V_{DR}$	$V_{CC}$ for data retention		1.5	–	–	V
$I_{CCDR}$ <sup>[14]</sup>	Data retention current	$V_{CC} = 1.5$ V, $\overline{CE} \geq V_{CC} - 0.2$ V, $V_{IN} \geq V_{CC} - 0.2$ V or $V_{IN} \leq 0.2$ V	–	0.8	7	$\mu$ A
$t_{CDR}$ <sup>[15]</sup>	Chip deselect to data retention time		0	–	–	ns
$t_R$ <sup>[16]</sup>	Operation recovery time	CY62148EV30LL-45	45	–	–	ns
		CY62148EV30LL-55	55	–	–	ns

## Data Retention Waveform

Figure 2. Data Retention Waveform

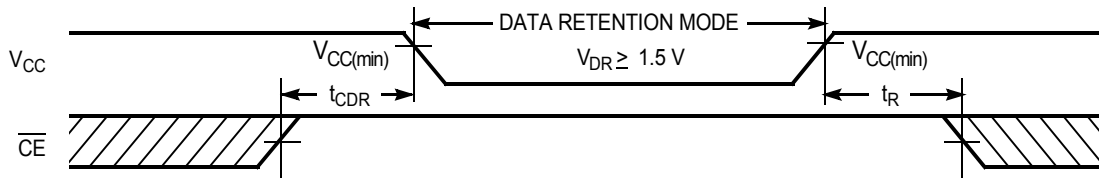

### Notes

13. Typical values are included for reference only and are not guaranteed or tested. Typical values are measured at  $V_{CC} = V_{CC(typ)}$ ,  $T_A = 25$  °C.
14. Chip Enable ( $\overline{CE}$ ) must be HIGH at CMOS level to meet the  $I_{SB1} / I_{SB2} / I_{CCDR}$  spec. Other inputs can be left floating.
15. Tested initially and after any design or process changes that may affect these parameters.
16. Full device AC operation requires linear  $V_{CC}$  ramp from  $V_{DR}$  to  $V_{CC(min)}$   $\geq 100$   $\mu$ s or stable at  $V_{CC(min)}$   $\geq 100$   $\mu$ s.

## Switching Characteristics

Over the Operating Range

Parameter [17, 18]	Description	-45 (Industrial / Automotive-A)		-55 [19]		Unit
		Min	Max	Min	Max	
<b>Read Cycle</b>						
$t_{RC}$	Read cycle time	45	–	55	–	ns
$t_{AA}$	Address to data valid	–	45	–	55	ns
$t_{OHA}$	Data hold from address change	10	–	10	–	ns
$t_{ACE}$	$\overline{CE}$ LOW to data valid	–	45	–	55	ns
$t_{DOE}$	$\overline{OE}$ LOW to data valid	–	22	–	25	ns
$t_{LZOE}$	$\overline{OE}$ LOW to Low Z [20]	5	–	5	–	ns
$t_{HZOE}$	$\overline{OE}$ HIGH to High Z [20, 21]	–	18	–	20	ns
$t_{LZCE}$	$\overline{CE}$ LOW to Low Z [20]	10	–	10	–	ns
$t_{HZCE}$	$\overline{CE}$ HIGH to High Z [20, 21]	–	18	–	20	ns
$t_{PU}$	$\overline{CE}$ LOW to power up	0	–	0	–	ns
$t_{PD}$	$\overline{CE}$ HIGH to power down	–	45	–	55	ns
<b>Write Cycle [22]</b>						
$t_{WC}$	Write cycle time	45	–	55	–	ns
$t_{SCE}$	$\overline{CE}$ LOW to write end	35	–	40	–	ns
$t_{AW}$	Address setup to write end	35	–	40	–	ns
$t_{HA}$	Address hold from write end	0	–	0	–	ns
$t_{SA}$	Address setup to write start	0	–	0	–	ns
$t_{PWE}$	$\overline{WE}$ pulse width	35	–	40	–	ns
$t_{SD}$	Data setup to write end	25	–	25	–	ns
$t_{HD}$	Data hold from write end	0	–	0	–	ns
$t_{HZWE}$	$\overline{WE}$ LOW to High Z [20, 21]	–	18	–	20	ns
$t_{LZWE}$	$\overline{WE}$ HIGH to Low Z [20]	10	–	10	–	ns

### Notes

17. In an earlier revision of this device, under a specific application condition, READ and WRITE operations were limited to switching of the chip enable signal as described in the Application Note AN66311. However, the issue has been fixed and in production now, and hence, this Application Note is no longer applicable. It is available for download on our website as it contains information on the date code of the parts, beyond which the fix has been in production.
18. Test Conditions for all parameters other than tri-state parameters assume signal transition time of 3 ns or less (1 V/ns), timing reference levels of  $V_{CC(typ)}/2$ , input pulse levels of 0 to  $V_{CC(typ)}$ , and output loading of the specified  $I_{OL}/I_{OH}$  as shown in the Figure 1 on page 5.
19. SOIC package is available only in 55 ns speed bin.
20. At any given temperature and voltage condition,  $t_{HZCE}$  is less than  $t_{LZCE}$ ,  $t_{HZOE}$  is less than  $t_{LZOE}$ , and  $t_{HZWE}$  is less than  $t_{LZWE}$  for any given device.
21.  $t_{HZOE}$ ,  $t_{HZCE}$ , and  $t_{HZWE}$  transitions are measured when the output enter a high impedance state.
22. The internal write time of the memory is defined by the overlap of  $\overline{WE}$ ,  $\overline{CE} = V_{IL}$ . All signals must be ACTIVE to initiate a write and any of these signals can terminate a write by going INACTIVE. The data input setup and hold timing must be referenced to the edge of the signal that terminates the write.

## Switching Waveforms

Figure 3. Read Cycle No. 1 (Address Transition Controlled) [23, 24]

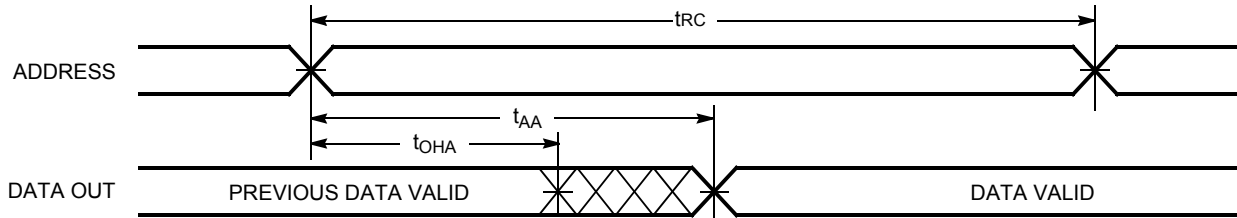

Figure 4. Read Cycle No. 2 ( $\overline{OE}$  Controlled) [24, 25]

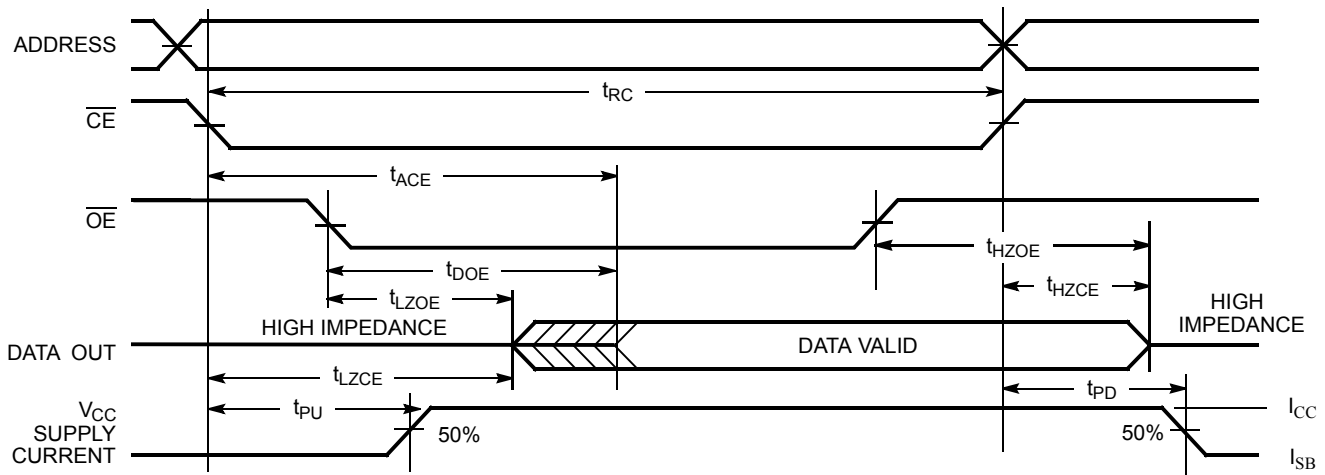
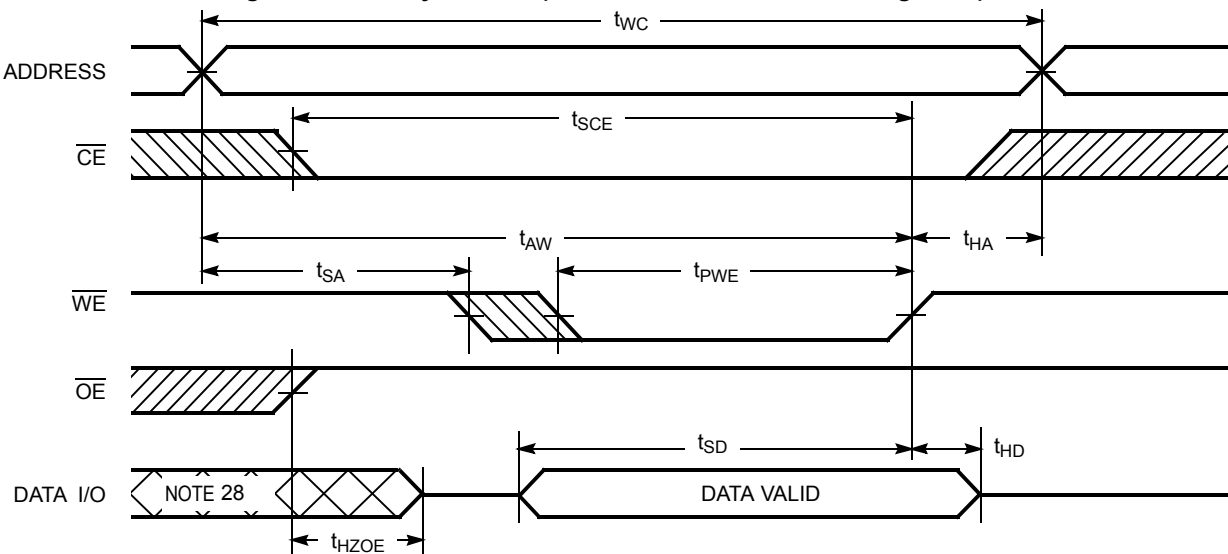

Figure 5. Write Cycle No. 1 ( $\overline{WE}$  Controlled,  $\overline{OE}$  HIGH During Write) [26, 27]



### Notes

- 23. Device is continuously selected.  $\overline{OE}$ ,  $\overline{CE}$  =  $V_{IL}$ .
- 24.  $\overline{WE}$  is HIGH for read cycles.
- 25. Address valid before or similar to  $\overline{CE}$  transition LOW.
- 26. Data I/O is high impedance if  $\overline{OE}$  =  $V_{IH}$ .
- 27. If  $\overline{CE}$  goes HIGH simultaneously with  $\overline{WE}$  HIGH, the output remains in high impedance state.
- 28. During this period, the I/Os are in output state. Do not apply input signals.



Switching Waveforms (continued)

Figure 6. Write Cycle No. 2 ( $\overline{CE}$  Controlled) [29, 30]

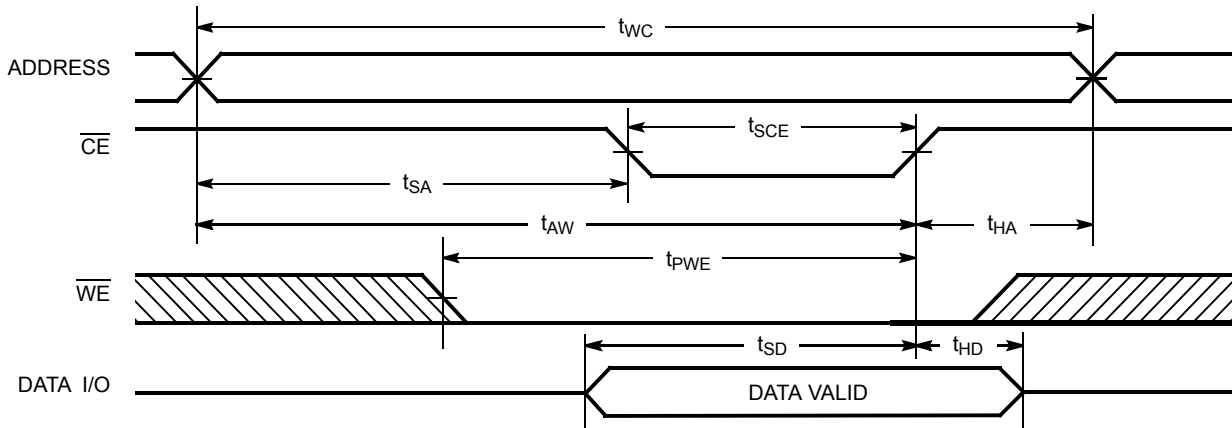
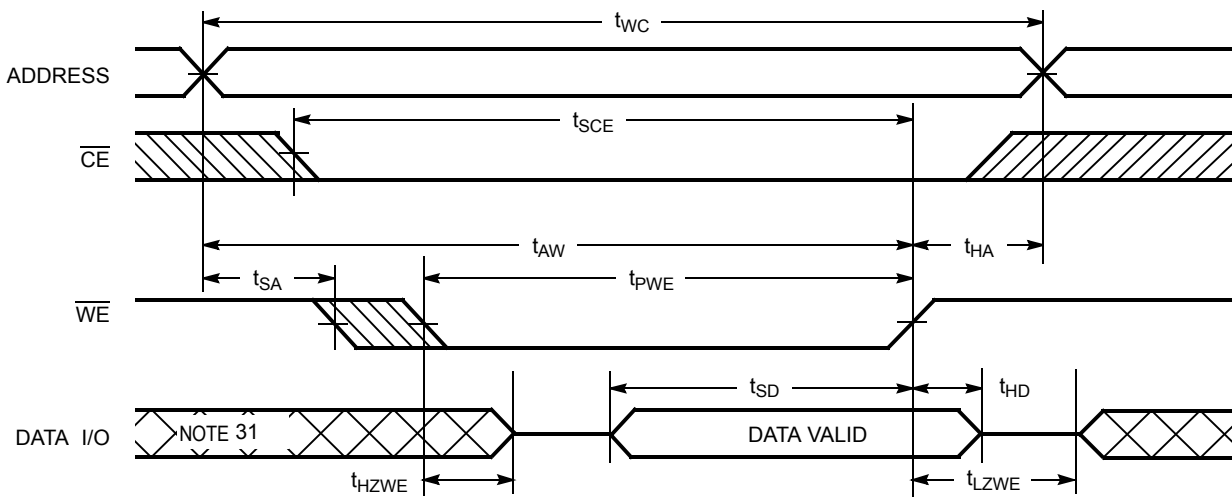

Figure 7. Write Cycle No. 3 ( $\overline{WE}$  Controlled,  $\overline{OE}$  LOW) [30]



Notes

- 29. Data I/O is high impedance if  $\overline{OE} = V_{IL}$ .
- 30. If  $\overline{CE}$  goes HIGH simultaneously with  $\overline{WE}$  HIGH, the output remains in high impedance state.
- 31. During this period, the I/Os are in output state. Do not apply input signals.

**Truth Table**

$\overline{CE}^{[32]}$	$\overline{WE}$	$\overline{OE}$	Inputs/Outputs	Mode	Power
H	X	X	High Z	Deselect/Power down	Standby ( $I_{SB}$ )
L	H	L	Data out	Read	Active ( $I_{CC}$ )
L	H	H	High Z	Output disabled	Active ( $I_{CC}$ )
L	L	X	Data in	Write	Active ( $I_{CC}$ )

**Note**

32. Chip enable must be at CMOS levels (not floating). Intermediate voltage levels on this pin is not permitted.

## Ordering Information

Speed (ns)	Ordering Code	Package Diagram	Package Type	Operating Range
45	CY62148EV30LL-45BVI	51-85149	36-ball VFBGA	Industrial
	CY62148EV30LL-45BVXI	51-85149	36-ball VFBGA (Pb-free)	
	CY62148EV30LL-45ZSXI	51-85095	32-pin TSOP II (Pb-free)	
	CY62148EV30LL-45ZSXA	51-85095	32-pin TSOP II (Pb-free)	Automotive-A
55	CY62148EV30LL-55SXI	51-85081	32-pin SOIC (Pb-free)	Industrial

Contact your local Cypress sales representative for availability of these parts.

## Ordering Code Definitions

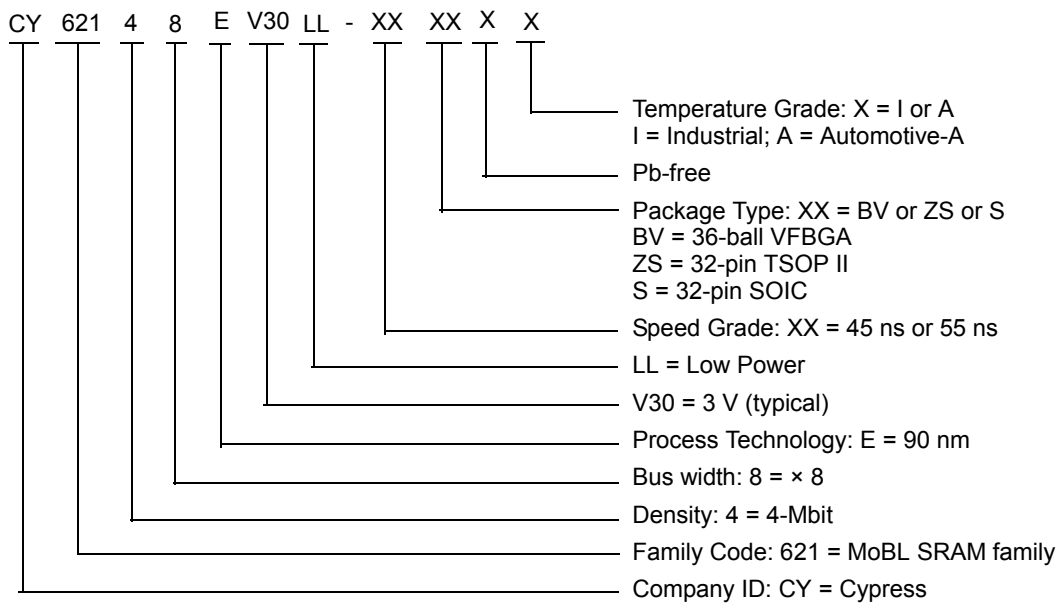

Package Diagrams

Figure 8. 36-ball VFBGA (6 × 8 × 1.0 mm) BV36A Package Outline, 51-85149

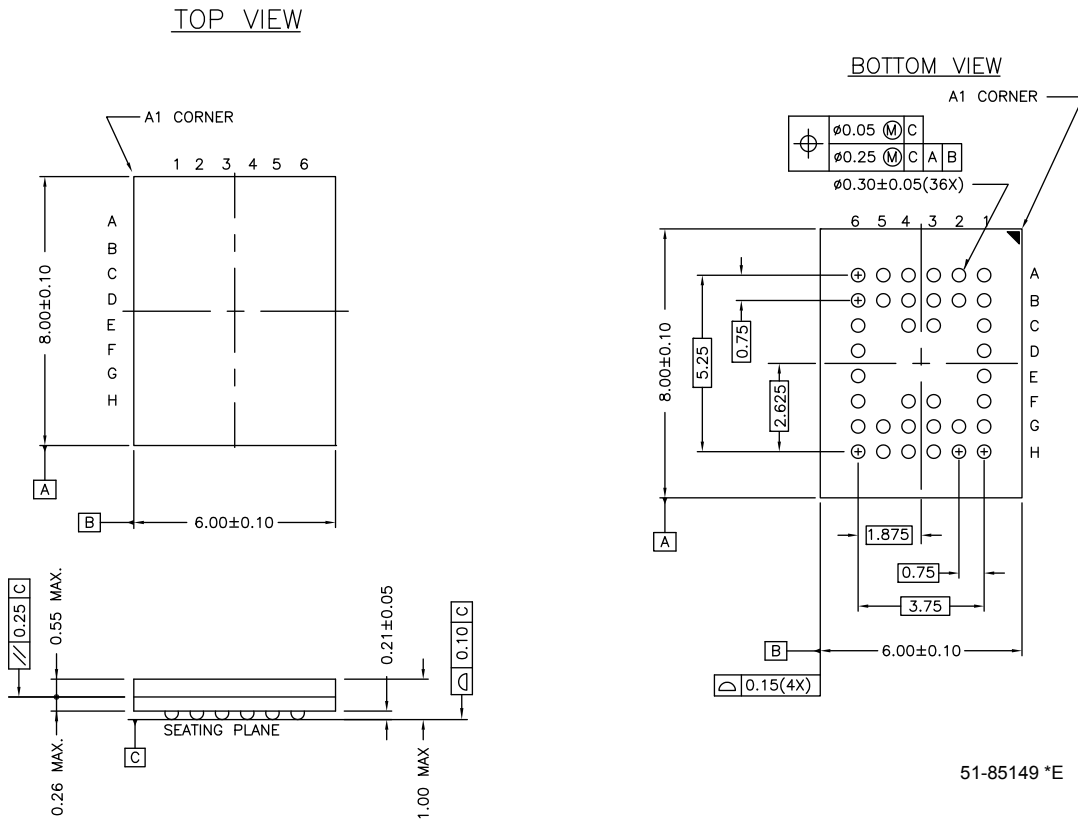

Package Diagrams (continued)

Figure 9. 32-pin TSOP II (20.95 × 11.76 × 1.0 mm) ZS32 Package Outline, 51-85095

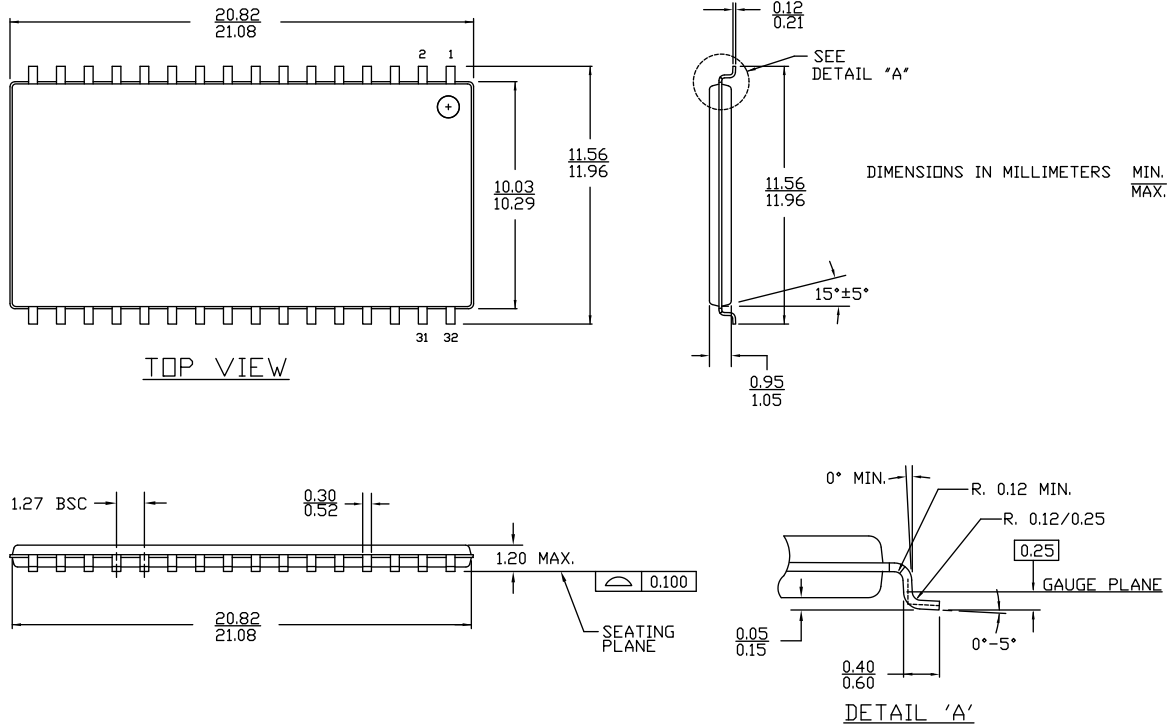

51-85095 \*B

Package Diagrams (continued)

Figure 10. 32-pin SOIC (450 Mils) S32.45/SZ32.45 Package Outline, 51-85081

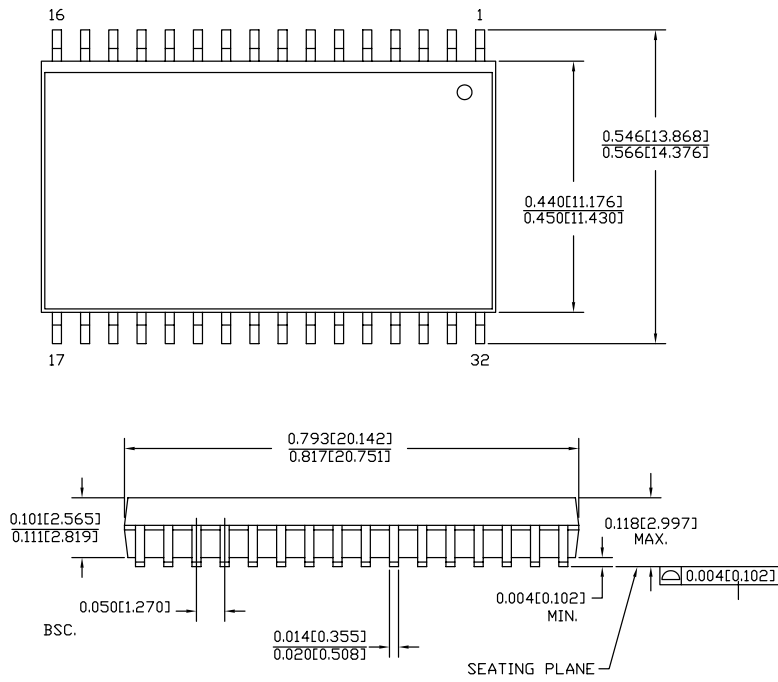

DIMENSIONS IN INCHES[MM] MIN.  
MAX.

PACKAGE WEIGHT: See Cypress Package Material Declaration Datasheet (PMDD) posted on the Cypress web.

PART #	
S32.45	STANDARD PKG.
SZ32.45	LEAD FREE PKG.

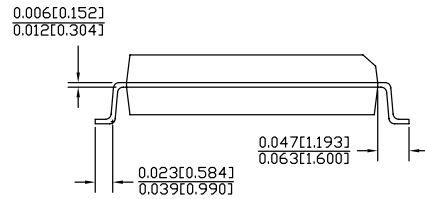

51-85081 \*E

## Acronyms

Acronym	Description
$\overline{\text{BHE}}$	Byte High Enable
$\overline{\text{BLE}}$	Byte Low Enable
CMOS	Complementary Metal Oxide Semiconductor
$\overline{\text{CE}}$	Chip Enable
I/O	Input/Output
$\overline{\text{OE}}$	Output Enable
SRAM	Static Random Access Memory
TSOP	Thin Small Outline Package
VFBGA	Very Fine-Pitch Ball Grid Array
$\overline{\text{WE}}$	Write Enable

## Document Conventions

### Units of Measure

Symbol	Unit of Measure
°C	degree Celsius
μA	microampere
mA	milliampere
ns	nanosecond
pF	picofarad
V	volt
W	watt

**Document History Page**

Document Title: CY62148EV30 MoBL <sup>®</sup> , 4-Mbit (512 K × 8) Static RAM				
Document Number: 38-05576				
Region	ECN	Submission Date	Orig. of Change	Description of Change
**	223225	See ECN	AJU	New data sheet.
*A	247373	See ECN	SYT	<p>Changed status from Advance Information to Preliminary.</p> <p>Updated <a href="#">Operating Range</a> (Updated Note 7 (Changed V<sub>CC</sub> stabilization time from 100 μs to 200 μs)).</p> <p>Updated <a href="#">Data Retention Characteristics</a> (Changed maximum value of I<sub>CCDR</sub> parameter from 2.0 μA to 2.5 μA, changed minimum value of t<sub>R</sub> parameter from 100 μs to t<sub>RC</sub> ns).</p> <p>Updated <a href="#">Switching Characteristics</a> (Changed minimum value of t<sub>OHA</sub> parameter from 6 ns to 10 ns for both 35 ns and 45 ns speed bin, changed maximum value of t<sub>DOE</sub> parameter from 15 ns to 18 ns for 35 ns speed bin, changed maximum value of t<sub>HZOE</sub>, t<sub>HZWE</sub> parameters from 12 ns to 15 ns for 35 ns speed bin and 15 ns to 18 ns for 45 ns speed bin, changed minimum value of t<sub>SCE</sub> from 25 ns to 30 ns for 35 ns speed bin and 40 ns to 35 ns for 45 ns speed bin, changed maximum value of t<sub>HZCE</sub> parameter from 12 ns to 18 ns for 35 ns speed bin and 15 ns to 22 ns for 45 ns speed bin, changed minimum value of t<sub>SD</sub> parameter from 15 ns to 18 ns for 35 ns speed bin and 20 ns to 22 ns for 45 ns speed bin).</p> <p>Updated <a href="#">Ordering Information</a> (Changed to include Pb-free Packages).</p>
*B	414807	See ECN	ZSD	<p>Changed status from Preliminary to Final.</p> <p>Changed the address of Cypress Semiconductor Corporation on page #1 from “3901 North First Street” to “198 Champion Court”.</p> <p>Updated <a href="#">Features</a> (Removed 35 ns speed bin).</p> <p>Updated <a href="#">Pin Configuration</a> (Changed ball C3 from DNU to NC, removed the Note “DNU pins have to be left floating or tied to V<sub>SS</sub> to ensure proper application.” and its reference, added 32-pin SOIC pinout).</p> <p>Updated <a href="#">Electrical Characteristics</a> (Removed “L” version of CY62148EV30, changed maximum value of I<sub>CC</sub> parameter from 2 mA to 2.5 mA and typical value of I<sub>CC</sub> parameter from 1.5 mA to 2 mA at f = 1 MHz, changed typical value of I<sub>CC</sub> parameter from 12 mA to 15 mA at f = f<sub>max</sub>, changed typical value of I<sub>SB1</sub> and I<sub>SB2</sub> parameters from 0.7 μA to 1 μA and maximum value of I<sub>SB1</sub> and I<sub>SB2</sub> parameters from 2.5 μA to 7 μA).</p> <p>Updated <a href="#">AC Test Loads and Waveforms</a> (Changed the AC test load capacitance value from 50 pF to 30 pF).</p> <p>Updated <a href="#">Data Retention Characteristics</a> (Changed maximum value of I<sub>CCDR</sub> parameter from 2.5 μA to 7 μA, added typical value of I<sub>CCDR</sub> parameter).</p> <p>Updated <a href="#">Switching Characteristics</a> (Changed minimum value of t<sub>LZOE</sub> parameter from 3 ns to 5 ns, changed minimum value of t<sub>LZCE</sub> and t<sub>LZWE</sub> parameters from 6 ns to 10 ns, changed maximum value of t<sub>HZCE</sub> parameter from 22 ns to 18 ns, changed minimum value of t<sub>PWE</sub> parameter from 30 ns to 35 ns, changed minimum value of t<sub>SD</sub> from 22 ns to 25 ns).</p> <p>Updated <a href="#">Ordering Information</a> (Updated part numbers and replaced the Package Name column with Package Diagram).</p> <p>Updated <a href="#">Package Diagrams</a> (Updated 36-pin VFBGA from *B to *C, added 32-pin SOIC package diagram (<a href="#">Figure 10</a>)).</p>
*C	464503	See ECN	NXR	<p>Updated <a href="#">Product Portfolio</a> (Included Automotive Range).</p> <p>Updated <a href="#">Operating Range</a> (Included Automotive Range).</p> <p>Updated <a href="#">Electrical Characteristics</a> (Included Automotive Range).</p> <p>Updated <a href="#">Data Retention Characteristics</a> (Included Automotive Range).</p> <p>Updated <a href="#">Switching Characteristics</a> (Included Automotive Range).</p> <p>Updated <a href="#">Ordering Information</a> (Updated part numbers (Included Automotive parts and their related information)).</p>



**Document History Page** (continued)

Document Title: CY62148EV30 MoBL <sup>®</sup> , 4-Mbit (512 K × 8) Static RAM				
Document Number: 38-05576				
Region	ECN	Submission Date	Orig. of Change	Description of Change
*D	833080	See ECN	VKN	Updated <a href="#">Electrical Characteristics</a> (Added V <sub>IL</sub> parameter for SOIC package, added Note 10 and referred the same note in the maximum value of V <sub>IL</sub> parameter for SOIC package).
*E	890962	See ECN	VKN	Updated <a href="#">Features</a> (Added Note 1 and referred the same note in 32-pin SOIC package). Updated <a href="#">Product Portfolio</a> (Removed Automotive Range). Updated <a href="#">Operating Range</a> (Removed Automotive Range). Updated <a href="#">Electrical Characteristics</a> (Removed Automotive Range, added Note 11 and referred the same note in I <sub>SB2</sub> parameter). Updated <a href="#">Data Retention Characteristics</a> (Removed Automotive Range). Updated <a href="#">Switching Characteristics</a> (Removed Automotive Range). Updated <a href="#">Switching Characteristics</a> (Added values for all parameters for 55 ns Industrial range). Updated <a href="#">Ordering Information</a> (Updated part numbers).
*F	987940	See ECN	VKN	Updated <a href="#">Electrical Characteristics</a> (Changed maximum value of V <sub>OL</sub> parameter from 0.4 V to 0.2 V for Industrial Range at I <sub>OL</sub> = 0.1 mA, changed maximum value of V <sub>IL</sub> parameter from 0.6 V to 0.4 V for Industrial Range, SOIC package at V <sub>CC</sub> = 2.2 V to 2.7 V, updated Note 10, updated Note 11 (made the note applicable for both I <sub>SB2</sub> and I <sub>CDDR</sub> parameters).
*G	2548575	08/05/08	NXR	Updated <a href="#">Features</a> (Included Automotive-A Range). Updated <a href="#">Product Portfolio</a> (Included Automotive-A Range). Updated <a href="#">Operating Range</a> (Included Automotive-A Range). Updated <a href="#">Electrical Characteristics</a> (Included Automotive-A Range). Updated <a href="#">Data Retention Characteristics</a> (Included Automotive-A Range). Updated <a href="#">Switching Characteristics</a> (Included Automotive-A Range). Updated <a href="#">Ordering Information</a> (Updated part numbers (Included Automotive-A parts and their related information)).
*H	2769239	09/25/09	VKN / AESA	Updated <a href="#">Ordering Information</a> (Updated part numbers).
*I	2944332	06/04/2010	VKN	Updated <a href="#">Truth Table</a> (Added Note 32 and referred the same note in CE column). Updated <a href="#">Package Diagrams</a> .
*J	3007403	08/13/2010	AJU	Added <a href="#">Ordering Code Definitions</a> . Updated in new template.
*K	3110202	12/14/2010	PRAS	Updated <a href="#">Logic Block Diagram</a> . Updated <a href="#">Ordering Code Definitions</a> .
*L	3302901	07/06/2011	RAME	Updated <a href="#">Functional Description</a> (Removed the reference of AN1064). Updated <a href="#">Ordering Code Definitions</a> . Updated <a href="#">Package Diagrams</a> (51-85095). Updated all the notes. Updated in new template.
*M	3363097	09/07/2011	AJU	Updated <a href="#">Data Retention Characteristics</a> (Corrected Note cross-reference for I <sub>CDDR</sub> parameter (Added Note 14 and referred the same note in I <sub>CDDR</sub> parameter)). Updated <a href="#">Package Diagrams</a> (Updated 36-ball VFBGA and 32-pin SOIC package specs).
*N	3546715	03/09/2012	TAVA	Updated <a href="#">Electrical Characteristics</a> (Updated Note 10 (Removed the line "Refer to AN13470 for details".)).
*O	3733339	09/04/2012	JISH	Minor text edits. Sunset review.

**Document History Page** (continued)

Document Title: CY62148EV30 MoBL®, 4-Mbit (512 K × 8) Static RAM				
Document Number: 38-05576				
Region	ECN	Submission Date	Orig. of Change	Description of Change
*P	4102967	08/23/2013	VINI	<p>Updated <a href="#">Switching Characteristics</a>: Added Note 17 and referred the same note in "Parameter" column.</p> <p>Updated <a href="#">Package Diagrams</a>: spec 51-85081 – Changed revision from *D to *E.</p> <p>Updated in new template.</p> <p>Completing Sunset Review.</p>
*Q	4307881	04/09/2014	NILE	<p>Updated <a href="#">Switching Characteristics</a>: Updated description of <math>t_{PD}</math> parameter (Replaced "<math>\overline{CE}</math> HIGH to power up" with "<math>\overline{CE}</math> HIGH to power down").</p>

## Sales, Solutions, and Legal Information

### Worldwide Sales and Design Support

Cypress maintains a worldwide network of offices, solution centers, manufacturer's representatives, and distributors. To find the office closest to you, visit us at [Cypress Locations](#).

#### Products

Automotive	<a href="http://cypress.com/go/automotive">cypress.com/go/automotive</a>
Clocks & Buffers	<a href="http://cypress.com/go/clocks">cypress.com/go/clocks</a>
Interface	<a href="http://cypress.com/go/interface">cypress.com/go/interface</a>
Lighting & Power Control	<a href="http://cypress.com/go/powerpsoc">cypress.com/go/powerpsoc</a> <a href="http://cypress.com/go/plc">cypress.com/go/plc</a>
Memory	<a href="http://cypress.com/go/memory">cypress.com/go/memory</a>
PSoC	<a href="http://cypress.com/go/psoc">cypress.com/go/psoc</a>
Touch Sensing	<a href="http://cypress.com/go/touch">cypress.com/go/touch</a>
USB Controllers	<a href="http://cypress.com/go/USB">cypress.com/go/USB</a>
Wireless/RF	<a href="http://cypress.com/go/wireless">cypress.com/go/wireless</a>

#### PSoC<sup>®</sup> Solutions

[psoc.cypress.com/solutions](http://psoc.cypress.com/solutions)  
PSoC 1 | PSoC 3 | PSoC 4 | PSoC 5LP

#### Cypress Developer Community

[Community](#) | [Forums](#) | [Blogs](#) | [Video](#) | [Training](#)

#### Technical Support

[cypress.com/go/support](http://cypress.com/go/support)

---

© Cypress Semiconductor Corporation, 2004-2014. The information contained herein is subject to change without notice. Cypress Semiconductor Corporation assumes no responsibility for the use of any circuitry other than circuitry embodied in a Cypress product. Nor does it convey or imply any license under patent or other rights. Cypress products are not warranted nor intended to be used for medical, life support, life saving, critical control or safety applications, unless pursuant to an express written agreement with Cypress. Furthermore, Cypress does not authorize its products for use as critical components in life-support systems where a malfunction or failure may reasonably be expected to result in significant injury to the user. The inclusion of Cypress products in life-support systems application implies that the manufacturer assumes all risk of such use and in doing so indemnifies Cypress against all charges.

Any Source Code (software and/or firmware) is owned by Cypress Semiconductor Corporation (Cypress) and is protected by and subject to worldwide patent protection (United States and foreign), United States copyright laws and international treaty provisions. Cypress hereby grants to licensee a personal, non-exclusive, non-transferable license to copy, use, modify, create derivative works of, and compile the Cypress Source Code and derivative works for the sole purpose of creating custom software and or firmware in support of licensee product to be used only in conjunction with a Cypress integrated circuit as specified in the applicable agreement. Any reproduction, modification, translation, compilation, or representation of this Source Code except as specified above is prohibited without the express written permission of Cypress.

Disclaimer: CYPRESS MAKES NO WARRANTY OF ANY KIND, EXPRESS OR IMPLIED, WITH REGARD TO THIS MATERIAL, INCLUDING, BUT NOT LIMITED TO, THE IMPLIED WARRANTIES OF MERCHANTABILITY AND FITNESS FOR A PARTICULAR PURPOSE. Cypress reserves the right to make changes without further notice to the materials described herein. Cypress does not assume any liability arising out of the application or use of any product or circuit described herein. Cypress does not authorize its products for use as critical components in life-support systems where a malfunction or failure may reasonably be expected to result in significant injury to the user. The inclusion of Cypress' product in a life-support systems application implies that the manufacturer assumes all risk of such use and in doing so indemnifies Cypress against all charges.

Use may be limited by and subject to the applicable Cypress software license agreement.