

PLCC Lightbar FPC 5630 Series Datasheet



Features :

- High Brightness SMD LED
- Low Power Requirement & Energy Efficient
- Suitable for Restricted Space

Typical Applications :

- Auditorium Walkway Lighting
- Stairway Accent Lighting
- Cabinet Lighting

Specification :

- Color : ○ ● ●

Table of Contents

General Information.....	3
Product Dimensions.....	4
Absolute Maximum Ratings	5
Electric-Optical Characteristics (T _j =25°C).....	6
Product Packaging Information	7
Environmental Compliance	8
Application Notes.....	8
Revision History	9
About Edison Opto	9

General Information

Introduction

PLCC Lightbar FPC R is a strip of lighting module available in varying colors. Its flexible circuit board not only enables novel design thinking with bendable light source, but also offers a wide range of applications with dividable lighting segments.

Ordering Code Format

6
X1
L B R 1
X2
X X
X3
N
X4
X
X5
0 0 0 0 0 0 x
X6

X1		X2		X3		X4		X5		X6	
Item		Series		Emitting Color		Angle		Driver		Serial No.	
6	Module	LBR1	FPC	CW	Cool White	N	120	I	CV 12V	xxxxxxx	--
				NW	Neutral White			J	CV 24V		
				WW	Warm White						
				M6	CW+WW						

Product Dimensions

6LBR1xWNI000000x Series Dimensions (CV 12V)

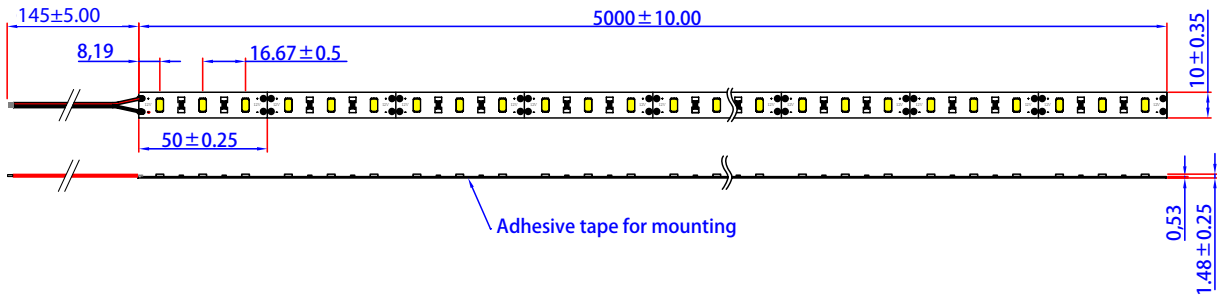

6LBR1xWNJ000000x Series Dimensions (CV 24V)

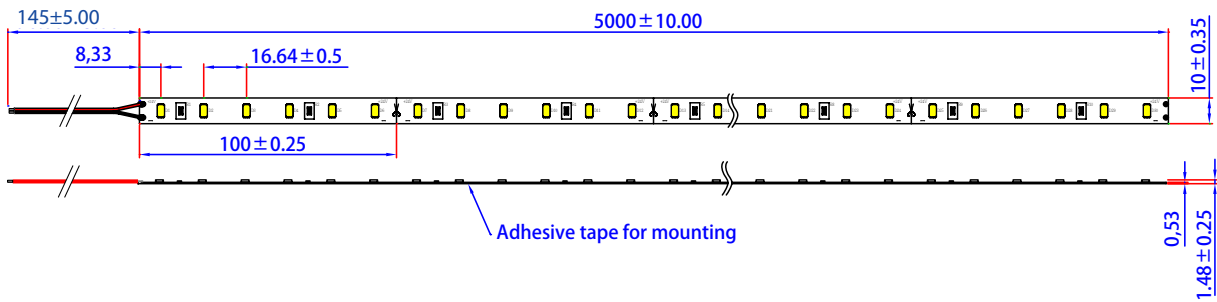

6LBR1M6NJ0000004 Series Dimensions (CV 24V)

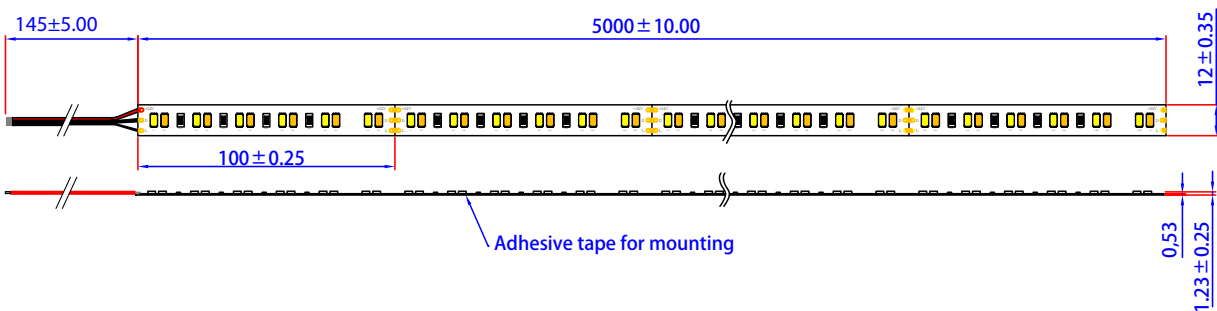

Notes:

1. All dimensions are in millimeters.
2. Tolerance is ± 0.20 mm

Absolute Maximum Ratings

Parameter	Symbol	Value	Units
LED junction Temperature	T_j	125	°C
Operating Temperature	T_{opr}	-20 ~ +40	°C
Storage Temperature	T_s	-20 ~ +85	°C
Number of FPC Connection	-	15	M

Notes:

1. Proper current derating must be observed to maintain junction temperature below the maximum at all time.
2. LEDs are not designed to be driven in reverse bias.
3. Strongly recommended one power connection one set FPC, If over two set FPC recommended connection power between two FPC (Drawing).

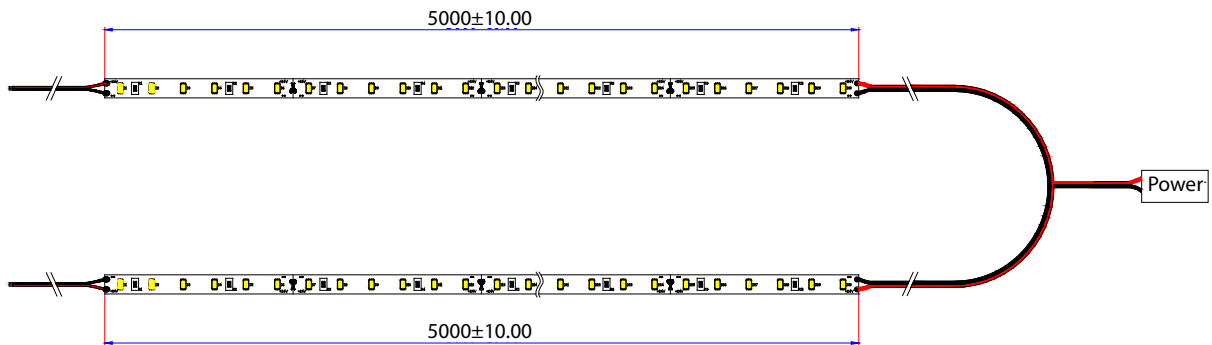

Electric-Optical Characteristics (T_j=25°C)

6LBR1xWNI000000x Series (CV 12V)

Order Code	Color	CCT(K)	Input Voltage (CV)	I _m (M)	Number of LEDs (M)	Power (W/M)	Forward Current (mA/M)	CRI
6LBR1CWNI0000004	Cool White	6000K	12	1248	60	14.4	1200	80
6LBR1NWNII0000004	Neutral White	4000K	12	1200	60	14.4	1200	80
6LBR1WWNI0000005	Warm White	3000K	12	1152	60	14.4	1200	80

6LBR1xWNJ000000x Series (CV 24V)

Order Code	Color	CCT(K)	Input Voltage (CV)	I _m (M)	Number of LEDs (M)	Power (W/M)	Forward Current (mA/M)	CRI
6LBR1CWNJ0000006	Cool White	6000K	24	1248	60	14.4	600	80
6LBR1NWNJ0000007	Neutral White	4000K	24	1200	60	14.4	600	80
6LBR1WWNJ0000008	Warm White	3000K	24	1152	60	14.4	600	80

6LBR1M6NJ0000004 Series (CV 24V)

Order Code	Color	CCT(K)	Input Voltage (CV)	I _m (M)	Number of LEDs (M)	Power (W/M)	Forward Current (mA/M)	CRI
6LBR1M6NJ0000004	Cool White	6000K	24	1248	60	14.4	600	80
	Warm White	3000K	24	1152	60	14.4	600	80

Notes:

1. CCT/Wavelength is measured with an accuracy of ± 10%
2. Forward Current is measured with an accuracy of ± 10%



Product Packaging Information

PLCC Lightbar FPC Material Description

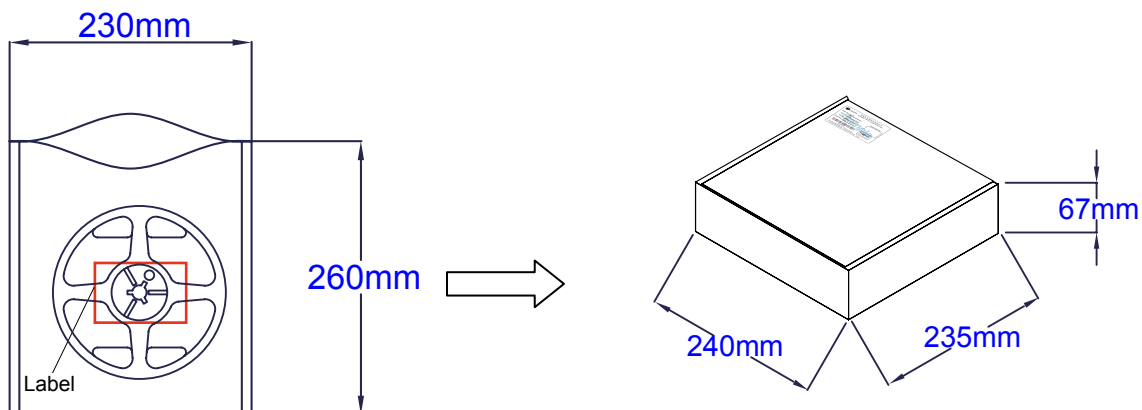
Package Type	Part NO.	6LBR1xxNx000000x	Dimension
Antistatic bag		1 Reel	260mm x 230mm
Inside box		4 Antistatic bags	240mm x 235mm x 67mm
Outside box		10 Inside boxes	488mm x 364mm x 261mm



EX:

 艾笛森光電股份有限公司 EDISON OPTO CORPORATION	
Part No. : <u>6LBR1CWNJ0000005</u>	Inspected by:
Color : <u>Cool White(34W3FVB2)</u>	
Quantity : <u>1 Reel(5M)</u>	
Lot No. : <u>D1201-12110022</u>	
 A410000005	
Tel +86-2-82276996 Fax +86-2-8227-6997 4F No.800 Chung-Cheng .., Chung-Ho City Taipei, Taiwan	

Label information

Part NO. : Order code
 Color : Color(Emitter BIN color)
 Quantity : The number of packing
 Lot NO. : Date code

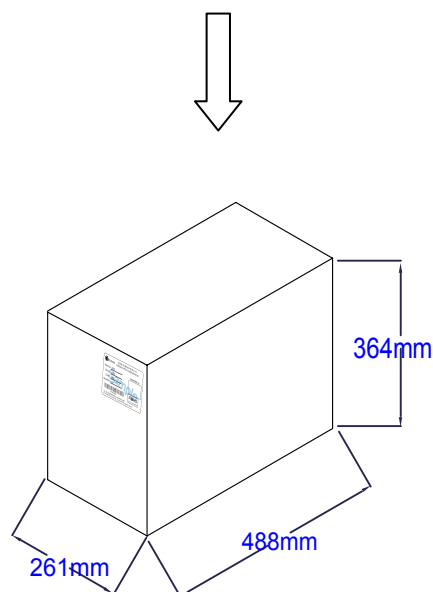

Environmental Compliance

PLCC lightbar FPC series are compliant to the Restriction of Hazardous Substances Directive or RoHS. The restricted materials including lead, mercury cadmium hexavalent chromium, polybrominated biphenyls (PBB) and polybrominated diphenyl ether (PBDE) are not used in PLCC lightbar FPC series to provide an environmentally friendly product to the customers.

Application Notes

PLCC Lightbar series are available in red, yellow, green, blue, white, neutral white and warm white for application such as under-cabinet lighting, cove lighting and wall washing. Moreover, additional fine-tuned high color rendering index (CRI) version of white, neutral white and warm white all make PLCC Lightbar the ideal lighting choice for vividly building or decoration products, presenting the products outline.

Revision History

Versions	Description	Release Date
1	Establish order code information	2013/06/19
2	1. Update the Emitting Color of order code format and CRI 2. Add the label information	2013/07/23

About Edison Opto

Edison Opto is a leading manufacturer of high power LED and a solution provider experienced in LDMS. LDMS is an integrated program derived from the four essential technologies in LED lighting applications- Thermal Management, Electrical Scheme, Mechanical Refinement, Optical Optimization, to provide customer with various LED components and modules. More Information about the company and our products can be found at www.edison-opto.com

Copyright©2013 Edison Opto. All rights reserved. No part of publication may be reproduced or transmitted in any form or by any means, electronic or mechanical, including photo copy, recording or any other information storage and retrieval system, without prior permission in writing from the publisher. The information in this publication are subject to change without notice.

www.edison-opto.com

For general assistance please contact:
service@edison-opto.com.tw

For technical assistance please contact:
LED.Detective@edison-opto.com.tw