

# \*SPECIFICATION\*

**LEAD FREE**

CUSTOMER : COMET	APPROVED BY
CUS. PART NO. :	
COILS PART NO. : A70418026	
DATE : 2007/04/19	

**1. DIMENSIONS (UNIT : mm)**

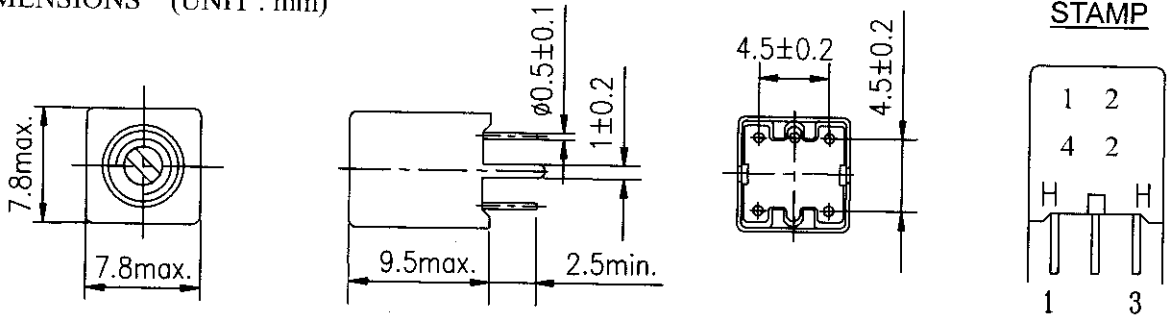

**2. CONNECTION (BOTTOM)**

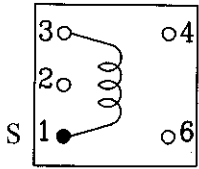

**3. TURNS , WIRE AND CORE**

PIN. NO.	1 - 3		
TURNS (ref.)	4 T		
WIRE	Ø0.12mm (2UEW)		
SCREW CORE	EM11	OR EQUIVALENT	
POT CORE	EM11	OR EQUIVALENT	

**4. CHARACTERISTICS**

ITEM	SPEC. ( 1 - 3 )	TESTING CONDITIONS	MEASUREMENT INSTRUMENT
VARIABLE INDUCTANCE	0.18 $\mu$ H $\pm$ 3% Min.	25.2MHz	MQ-1601
UNLOADED Q	45 Min.	25.2MHz	MQ-1601

**5. GENERAL CHARACTERISTICS:**

- ① Core Torque : 10 ~ 250gf · cm
- ② Dielectric Strength: No abnormality at 100V D.C. for 1 minute between winding-case.
- ③ Insulation Resistance: Over 100M $\Omega$  at 100V D.C. between winding-case.
- ④ Humidity Test : Frequency (Inductance) deviation within  $\pm$ 0.5% ( $\pm$ 1%)  
Deviation of Q within  $\pm$ 20%  
After 96 $\pm$ 4 hours in 90~95% relative humidity at 40 $^{\circ}$ C $\pm$ 2 $^{\circ}$ C and 60 minutes drying under normal condition.
- ⑤ Temperature Test : Frequency (Inductance) deviation within  $\pm$ 0.5% ( $\pm$ 1%)  
Deviation of Q within  $\pm$ 20%  
a. After 6 hours at -25 $^{\circ}$ C $\pm$ 3 $^{\circ}$ C and 1 hour later under normal condition.  
b. After 6 hours at 85 $^{\circ}$ C $\pm$ 2 $^{\circ}$ C and 1 hour later under normal condition.
- ⑥ Terminal Strength : No abnormality at 0.5kg for 30 $\pm$ 5 seconds (pull and push).
- ⑦ Terminal Heat Test: No abnormality at 250 $^{\circ}$ C $\pm$ 5 $^{\circ}$ C for 5 seconds.

**6. RoHS COMPLIANCE REMARKS:** LEAD WILL BE PRESENT IN THE FERRITE CORE OF THE FRIT MATRIX IN THE COMPONENT. THIS USE, IS EXEMPT FROM RoHS LEGISLATION PER THE ANNEX (ITEM7), WHICH REFERS TO "LEAD IN ELECTRONIC CERAMIC PART".

APPROVAL	CHECK	DESIGN	REVISION

# \*SPECIFICATION\*

LEAD FREE

CUSTOMER : COMET	APPROVED BY
CUS. PART NO. :	
COILS PART NO. : A70418026	
DATE : 2007/04/19	

## 7. CONSTRUCTION

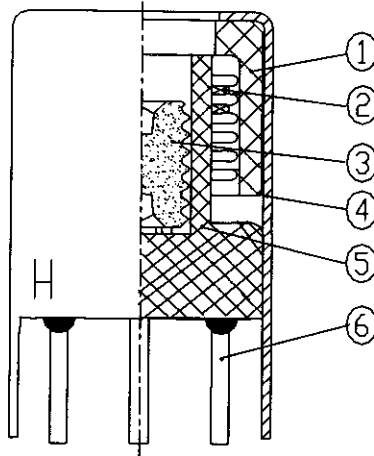

## 8. MATERIAL LIST

No.	PARTS	MATERIAL	MANUFACTURER	COUNTRY OF ORIGIN	UL No.	UL FLAME CLASS
①	POT CORE	FERRITE CORE EM11 OR EQUIVALENT	TONICHI FERRITE PRODUCTS CO., LTD.	CHINA	NA	NA
②	WIRE	POLYURETHANE ENAMELLED COPPER WIRE OR EQUIVALENT	PACIFIC-THAI ELECTRIC WIRE & CALBE CO., LTD.	THAILAND	E142108	NA
			JUNG SHING WIRE CO., LTD.	CHINA (TAIWAN)	E174837	NA
			TA YA ELECTRIC WIRE FACTORY	CHINA	E197768	NA
③	SCREW CORE	FERRITE CORE EM11 OR EQUIVALENT	TONICHI FERRITE PRODUCTS CO., LTD.	CHINA	NA	NA
④	CASE	BRASS H68 OR EQUIVALENT	TONICHI FERRITE PRODUCTS CO., LTD.	CHINA	NA	NA
⑤	BASE	PA66-1300G OR EQUIVALENT	ASAHI KASEI CHEMICALS CORP.	JAPAN	E48285	94HB
⑥	LEAD PIN	H.C.P OR EQUIVALENT	WELL FORE SPECIAL WIRE CORPORATION	CHINA (TAIWAN)	NA	NA
	SOLDER	Sn99.3-Cu0.7 OR EQUIVALENT	ALPHA METALS LTD.	CHINA (HONG KONG)	NA	NA
			YUNNAN TIN CO.,LTD	CHINA	NA	NA
	STAMP	INK(Z370) OR EQUIVALENT	TOYO INK.	JAPAN	NA	NA
	ADHESIVE	COMPOUND RESIN 666 OR EQUIVALENT	BAYER - W. GERMANY CO., LTD.	GERMANY	NA	NA

\* NA: NOT APPLICABLE

APPROVAL	CHECK	DESIGN	REVISION