

SWITCH CIRCUIT

MATERIAL AND FINISH AS BELOW

A	Housing	LCP UL94V-0 Black	E
B	Contact	Phosphor Bronze C5210,Contact Area: Gold Flash	F
C	Shell	Stainless Steel 304,Nickel Plating	G
D			H

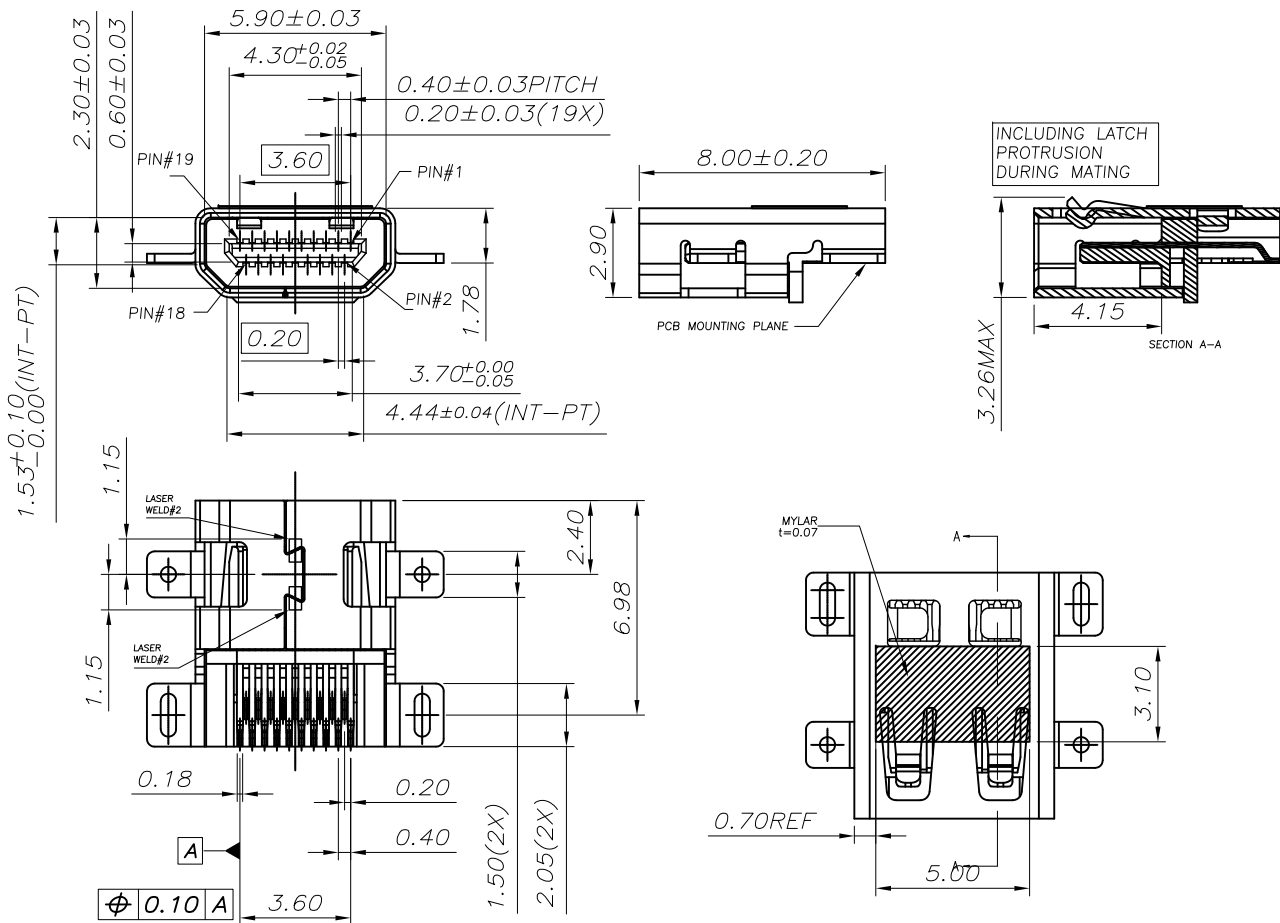

SPECIFICATION:

1. ELECTRICAL

- 1.1 Current Rating: 0.3A per pin**
- 1.2 Voltage Rating: 40V AC**
- 1.3 Contact Resistance: 10mΩ**
- 1.4 Insulation Resistance: 100MΩ**
- 1.5 Dielectric Withstanding Voltage:**
 Umated:250VAC
 Mated:150VAC

2. MECHANICAL

- 2.1 Durability: 5000 Cycle**
- 2.2 Insertion Force: 5~25N max.**
- 2.3 Extraction Force: 5~25N max.**

3. ENVIRONMENTAL

- 3.1 Operating temperature range: -25°C ~ +85°C**
- 3.2 Storage temperature range: -25°C ~ +85°C**

4. SOLDER ABILITY

- 4.1 Recommended IR Reflow Temperature: 260°C**
- 4.2 Recommended PCB Thickness: 1.0mm**

P1	P2	P3	P4	P5	P6	P7	P8	P9	P10	P11	P12
----	----	----	----	----	----	----	----	----	-----	-----	-----

PIN ASSIGNMENT

206H-SABN HDMI D Type, Middle Board Mount, SMD Type Gold Flash

PRODUCT NO. DESCRIPTION

UNLESS OTHERWISE SPECIFIED TOLERANCE

ANGLES	ANG.	±5°
LINEAR	0.	±0.3
	0.0	±0.25
	0.00	±0.20
SCALE	AS SHOWN	UNIT: mm
DRAWN	Willis	2012/09/12
CHECKED	Angel	2012/09/12
APPROVED	Ken	2012/09/12



www.attend.com.tw

DRAWN NAME: HDMI D Type Connector

PRODUCT NO. 206H-SABN

FILE NAME 206H-SABN_B_1

Revise:

Revise:

Revise:

REV.	DESCRIPTION	DATE	REV.	DESCRIPTION	DATE	SIZE	REV.	FILE NAME
1						A4	1.0	206H-SABN_B_1

PIN	SIGNAL ASSIGNMENT
1	Hot Plug Detect
2	Utility
3	TMDS Data2+
4	TMDS Data2 Shield
5	TMDS Data2-
6	TMDS Data1+
7	TMDS Data1 Shield
8	TMDS Data1-
9	TMDS Data0+
10	TMDS Data0 Shield
11	TMDS Data0-
12	TMDS Clock+
13	TMDS Clock Shield
14	TMDS Clock-
15	CEC
16	DDC/CEC Ground
17	SCL
18	SDA
19	+5V Power

CONNECTION	SIGNALS
	TYPE D CONNECTOR
FIRST MAKE	CONNECTOR SHELL
SECOND MAKE	PINS 1 - 18
THIRD MAKE	PIN 19 (+5V POWER)

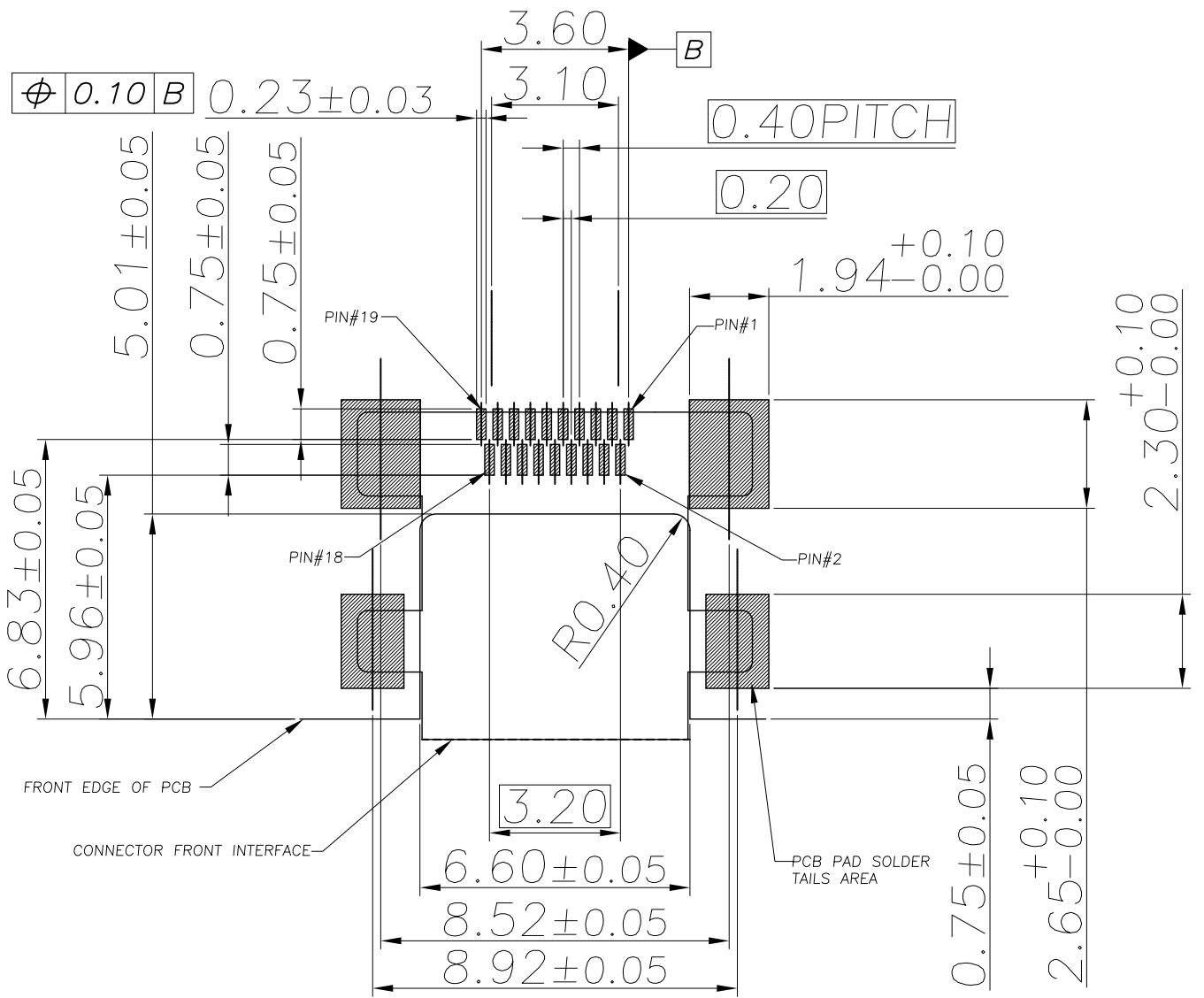

REV.	DESCRIPTION	DATE	REV.	DESCRIPTION	DATE
1			2		
3			4		
5			6		
7			8		
9			10		

UNLESS OTHERWISE SPECIFIED TOLERANCE		
ANGLES	ANG.	±5°
LINEAR	0.	±0.3
	0.0	±0.25
	0.00	±0.20
SCALE	AS SHOWN	UNIT: mm
DRAWN	Willis	2012/09/12
CHECKED	Angel	2012/09/12
APPROVED	Ken	2012/09/12
SIZE	A4	REV. 1.0



www.attend.com.tw

DRAWN NAME: HDMI D Type Connector

PRODUCT NO. 206H-SABN

FILE NAME 206H-SABN_B_1

- △ Revise:
- △ Revise:
- △ Revise:

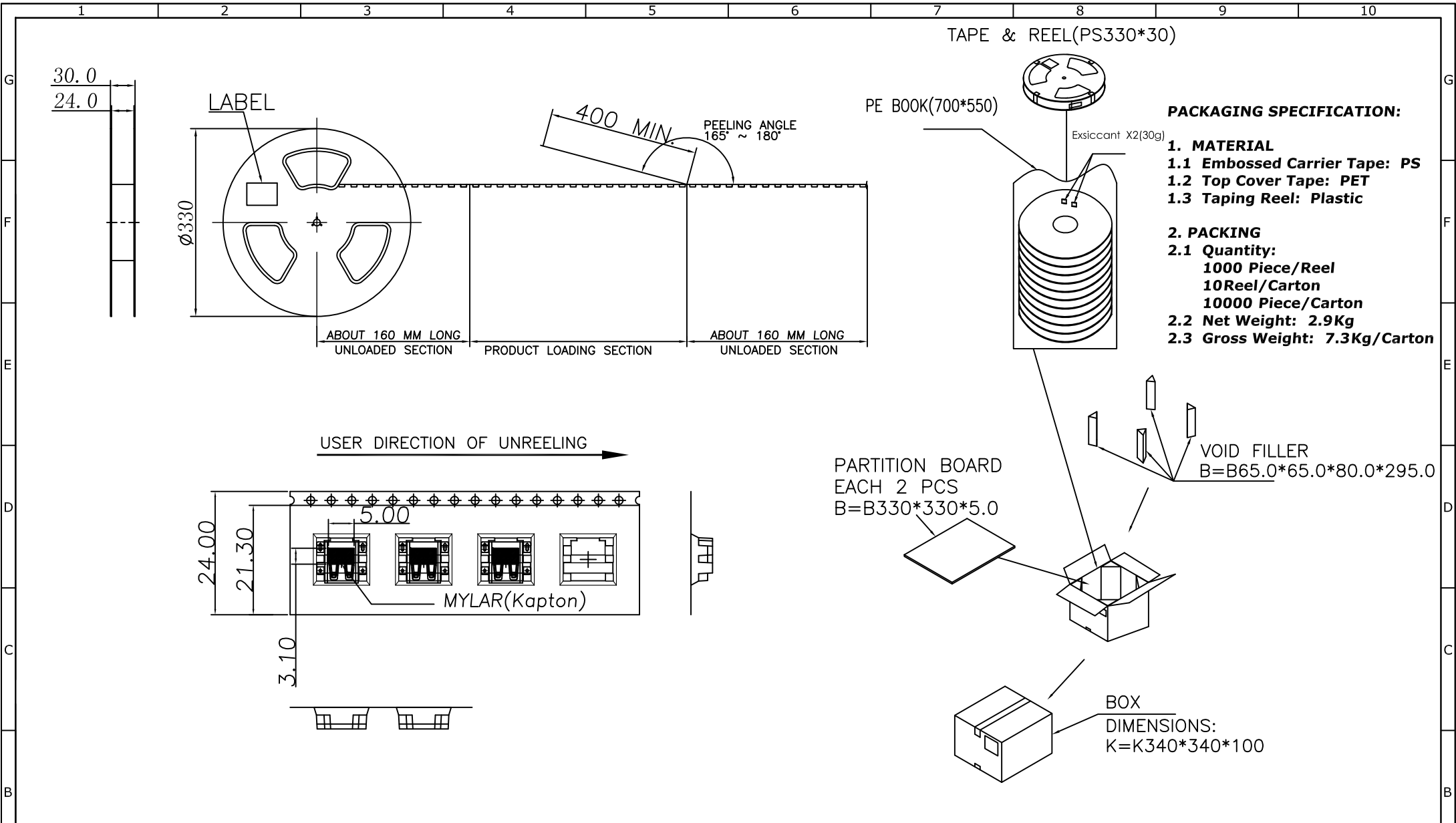

- PACKAGING SPECIFICATION:**
- 1. MATERIAL**
 - 1.1 Embossed Carrier Tape: PS
 - 1.2 Top Cover Tape: PET
 - 1.3 Taping Reel: Plastic
 - 2. PACKING**
 - 2.1 Quantity:
 - 1000 Piece/Reel
 - 10Reel/Carton
 - 10000 Piece/Carton
 - 2.2 Net Weight: 2.9Kg
 - 2.3 Gross Weight: 7.3Kg/Carton

REV.	DESCRIPTION	DATE	REV.	DESCRIPTION	DATE
1			4		
2			5		
3			6		

UNLESS OTHERWISE SPECIFIED TOLERANCE		
ANGLES	ANG.	±5°
LINEAR	0.	±0.3
	0.0	±0.25
	0.00	±0.20
SCALE	AS SHOWN	UNIT: mm
DRAWN	Willis	2012/09/12
CHECKED	Angel	2012/09/12
APPROVED	Ken	2012/09/12
SIZE	A4	REV. 1.0

ATTEND
www.attend.com.tw
 DRAWN NAME: HDMI D Type Connector
 PRODUCT NO. 206H-SABN
 FILE NAME 206H-SABN_D_1

A
A
A

A
A
A