

LQH2MCN100K02#

" # " indicates a package specification code.

Available **General** **85** **Wound (No Shield)** **Thickness 0.95mm max.** **Reflow OK** **RoHS**

< List of part numbers with package codes >
LQH2MCN100K02L , LQH2MCN100K02B

Shape

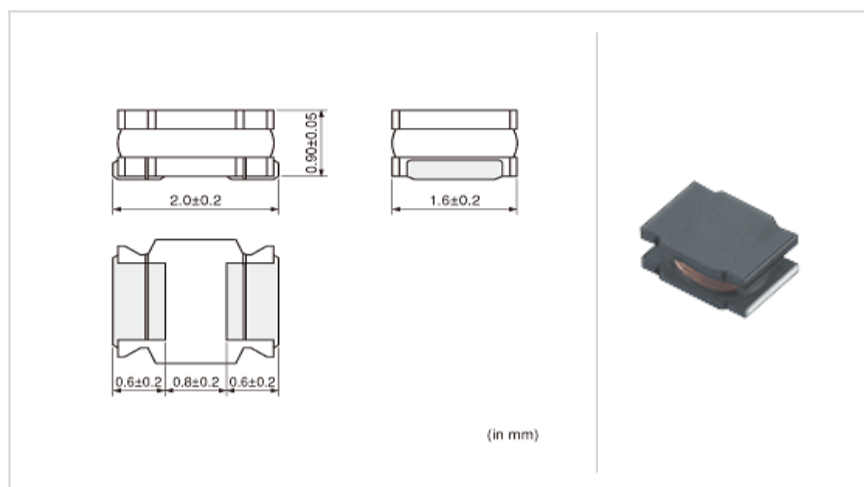

L size	2.0 ± 0.2mm
W size	1.6 ± 0.2mm
T size	0.9 ± 0.05mm
Size code in inch (mm)	0806 (2016)

Specifications

Inductance	10μH ± 10%
Inductance test frequency	1MHz
Rated current (Itemp) (Based on Temperature rise)	225mA
Max. of DC resistance	1.56
Avg. of DC resistance	1.2 ± 30%
Self resonance frequency (min.)	48MHz
Operating temperature range (Self-temperature rise is not included)	-40 ~ 85
Class of magnetic shield	No magnetic shield

Notes

When applied Rated current to the Products, Inductance will be within ± 10% of initial Inductance value.
When applied Rated current to the Products, temperature rise caused by self-generated heat shall be limited to 40 °C max.

References

Packaging code	Specifications	Minimum quantity
L	180mm Embossed taping	3000
B	Packing in bulk	100

Mass (Typ.)	
1 piece	0.010g

Attention

- 1.This datasheet is downloaded from the website of Murata Manufacturing Co., Ltd. Therefore, it ' s specifications are subject to change or our products in it may be discontinued without advance notice. Please check with our sales representatives or product engineers before ordering.
- 2.This datasheet has only typical specifications because there is no space for detailed specifications. Therefore, please review our product specifications or consult the approval sheet for product specifications before ordering.

Inductance-Frequency characteristics (Typ.)

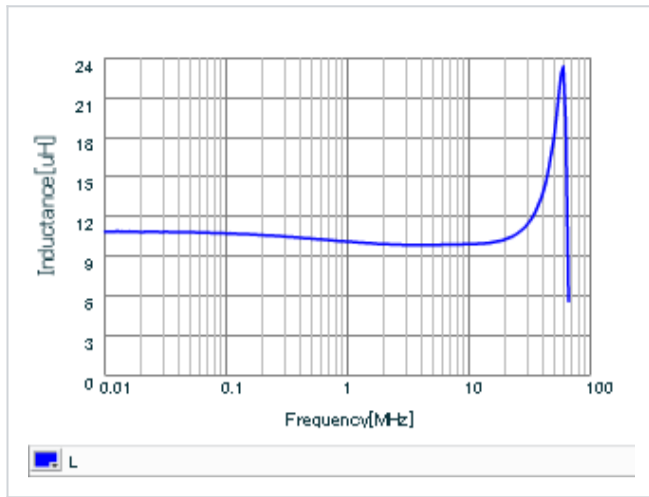

Inductance-Current characteristics (Typ.)

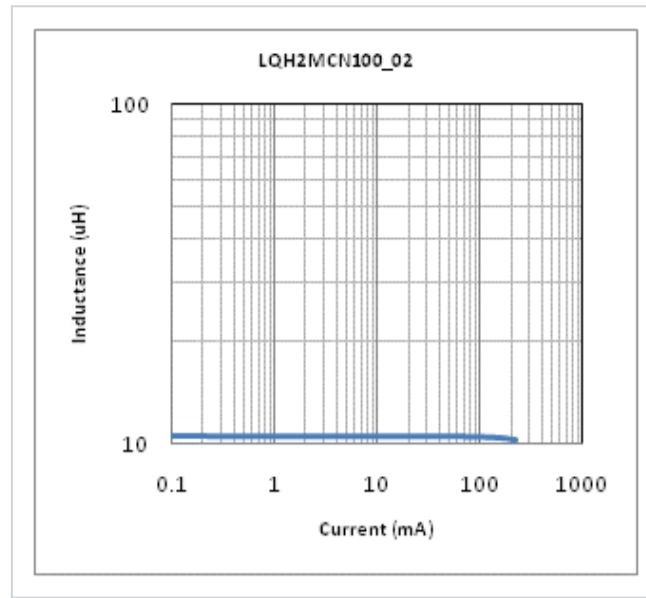

Temperature rise characteristics (Typ.)

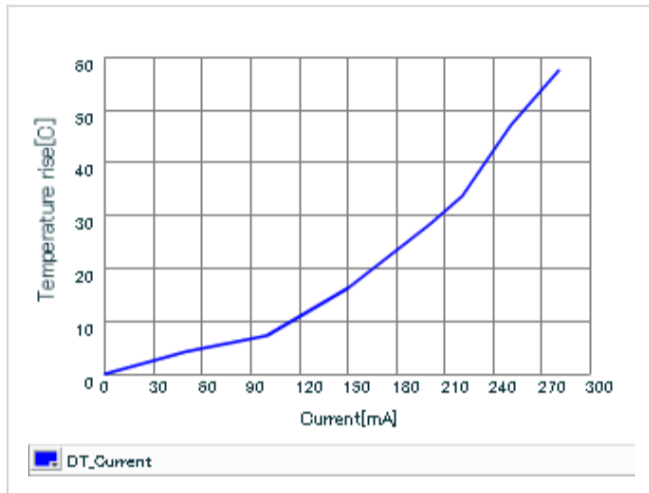

Q-Frequency characteristics (Typ.)

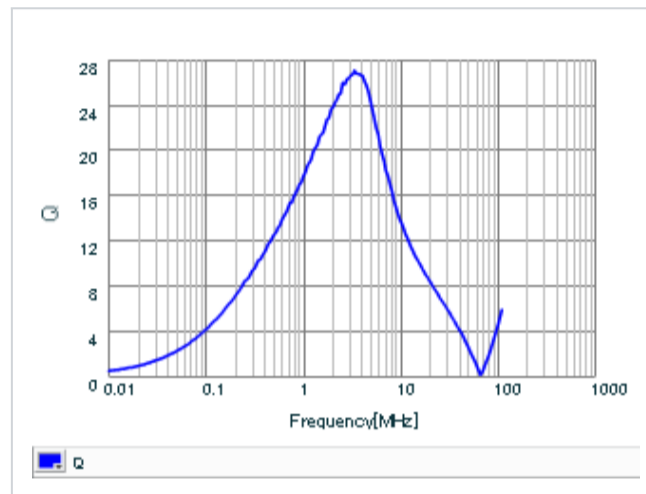

This PDF data has only typical specifications because there is no space for detailed specifications. Therefore, please review our product specifications or consult the approval sheet for product specifications before ordering.