

- NOTES:
- 1.DETAILED DIMENSION REFERENCE PRO/E DRAWING.
  - 2.WITHOUT SCRATCH AND GREASINESS
  - 3.BURR HEIGHT MUST BE UNDER 0.05MM.
  - 4.ROHS COMPLIANT
  - 5.SINK MATERIAL: AL6063-T5
  - 6.SINK SURFACE TREATMENT: ANODIZED BLACK
  - 7.SUNON PART NUMBER : SA000-14013N
  - 8.FIXING HOLES FOR ZHAGA、CLL012、XSM80XX-400-C

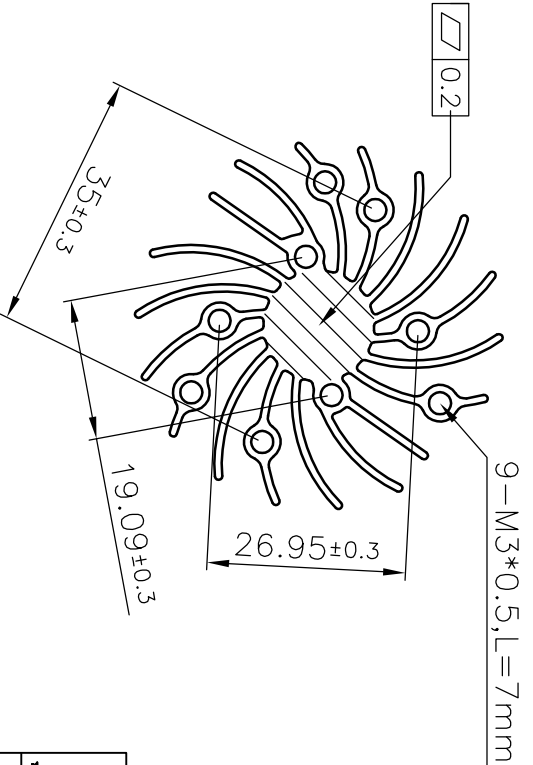
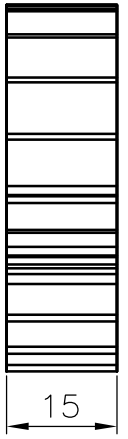
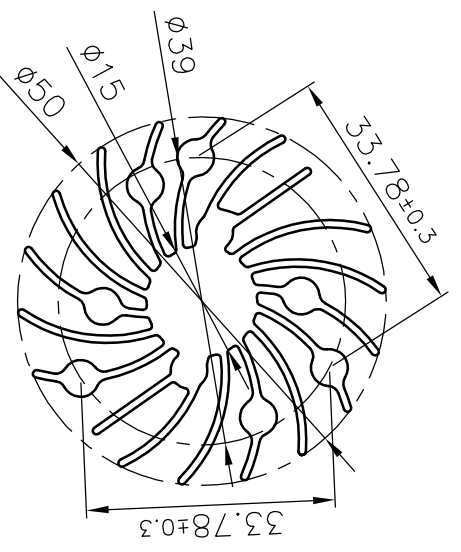
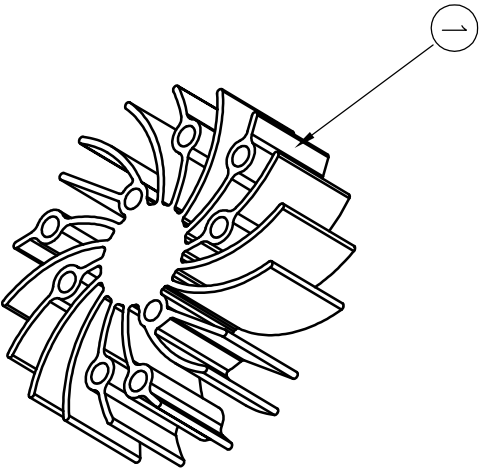

零件表  
PART DETAIL LIST

1	SINK	AL6063-T5	50*15mm	1
項次 ITEM	名稱 NAME	材質 MATERIAL	規格 SPECIFICATION	數量 QTY

公差 TOLERANCE	公差 SCALE	單位 UNIT	圖法 PROJECTION	繪圖 DRAWING	圖名 DWG NAME	圖號 DWG No.
mm	mm	mm	第一角法	James Cheng	SA000-14013N	50*15mm

專案號碼 PROJECT No.	開發圖號 DEV. DWG No.	參考圖號 REF. DWG No.	圖名 DWG NAME	圖號 DWG No.
			SA000-14013N	50*15mm

\*: dimension need to do critical control.

適用範圍  
SCOPE

項次 ITEM	修訂 E.C.	說明 DESCRIPTION	設計 DESIGN	確認 CHECKED	審核 APPROVED	圖法 PROJECTION	繪圖 DRAWING	James Cheng	SUNONWEALTH ELEC.MACH.CO.,LTD.	版次 REV.	0	1
------------	------------	-------------------	--------------	---------------	----------------	------------------	---------------	-------------	--------------------------------	------------	---	---