

- NOTES:
- 1.DETAIL DIMENSION REFERENCE PRO/E DRAWING.
 - 2.WITHOUT SCRATCH AND GREASINESS
 - 3.BURR HEIGHT MUST BE UNDER 0.05MM.
 - 4.ROHS COMPLIANT
 - 5.SINK MATERIAL: AL6063-T5
 - 6.SINK SURFACE TREATMENT: ANODIZED BLACK
 - 7.SUNON PART NUMBER : SA001-14007N
 - 8.FIXING HOLES FOR ZHAGA、CLL022、XSM80XX-700-C、BXRA-xxx0800/0950/1100、PL-CORE-Z3-1000

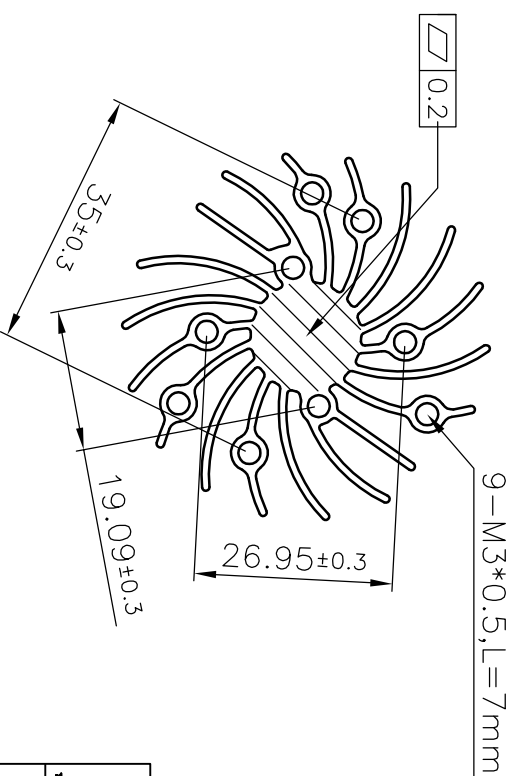
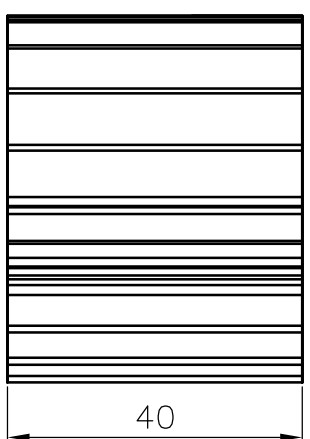
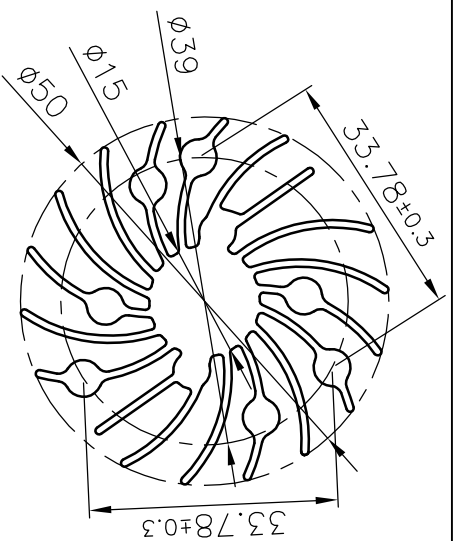
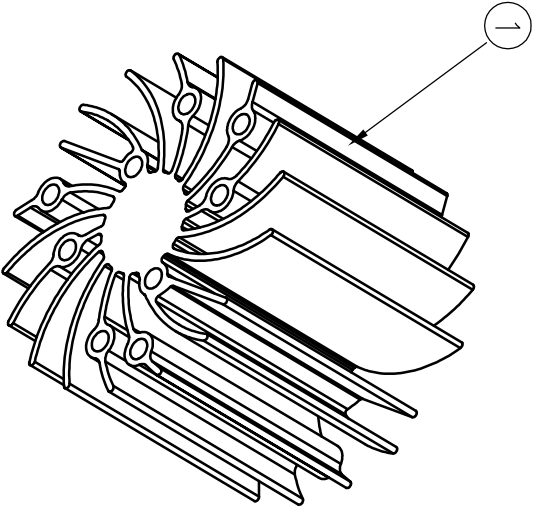

零件表
PART DETAIL LIST

項次 ITEM	名稱 NAME	材質 MATERIAL	規格 SPECIFICATION	數量 QTY
1	SINK	AL6063-T5	50*40mm	1

公差 TOLERANCE	公差 TOLERANCE	公差 TOLERANCE	公差 TOLERANCE	公差 TOLERANCE
比例 SCALE	比例 SCALE	比例 SCALE	比例 SCALE	比例 SCALE
單位 UNIT	單位 UNIT	單位 UNIT	單位 UNIT	單位 UNIT
mm	mm	mm	mm	mm

圖名 DWG NAME	專案號碼 PROJECT No.	SA001-14007N
圖號 DWG No.	開發圖號 DEV. DWG No.	50*40mm
*: dimension need to do critical control.		
適用範圍 SCOPE		

項次 ITEM	修訂 E.C.	說明 DESCRIPTION	設計 DESIGN	確認 CHECKED	審核 APPROVED	角法 PROJECTION	繪圖 DRAWING	James Cheng	專案號碼 PROJECT No.	開發圖號 DEV. DWG No.	參考圖號 REF. DWG No.	建達電機工業股份有限公司 SUNONWEALTH ELEC.MACH.CO.,LTD.	版次 REV.	0	1
------------	------------	-------------------	--------------	---------------	----------------	------------------	---------------	-------------	---------------------	----------------------	----------------------	--	------------	---	---